

OPERATION MANUAL

WITHSTANDING VOLTAGE/
INSULATION RESISTANCE TESTER
TOS9200 Series

TOS9200 TOS9201

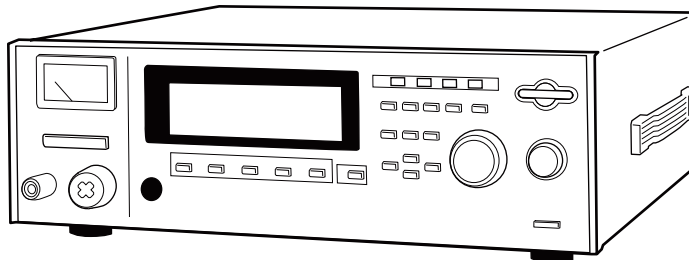

DANGER

This Tester generates high voltage.

- Any incorrect handling may cause death.
- Read Chapter 2 “PRECAUTIONS ON HANDLING” in this manual to prevent accident.
- Keep this manual near the tester for easy access of the operator.

Use of Operation Manual

Please read through and understand this Operation Manual before operating the product. After reading, always keep the manual nearby so that you may refer to it as needed. When moving the product to another location, be sure to bring the manual as well.

If you find any incorrectly arranged or missing pages in this manual, they will be replaced. If the manual it gets lost or soiled, a new copy can be provided for a fee. In either case, please contact Kikusui distributor/agent, and provide the “Kikusui Part No.” given on the cover.

This manual has been prepared with the utmost care; however, if you have any questions, or note any errors or omissions, please contact Kikusui distributor/agent.

Disposing of used Kikusui products in the EU

Under a law adopted by member nations of the European Union (EU), used electric and electronic products carrying the symbol below must be disposed of separately from general household waste.

This includes the power cords and other accessories bundled with the products. When disposing of a product subject to these regulations, please follow the guidance of your local authority, or inquire with your Kikusui distributor/agent where you purchased the product.

The symbol applies only to EU member nations.



Disposal outside the EU

When disposing of an electric or electronic product in a country that is not an EU member, please contact your local authority and ask for the correct method of disposal.

Reproduction and reprinting of this operation manual, whole or partially, without our permission is prohibited.

Both unit specifications and manual contents are subject to change without notice.

Interlock Function

The first time the tester is turned on following delivery, the interlock function activates and testing is disabled.

Before starting a test, read "4.3 INTERLOCK Connector" for the procedure for starting up the tester using the interlock function.

About this manual

This operation manual describes the withstanding voltage tester TOS9200/TOS9201.

■ **This manual is applicable to the Tester whose ROM version number is:**

Ver. 1.3X for TOS9200

Ver. 1.3X for TOS9201

You can check the version number on the opening screen at turning on the power or by using the *IDN? message.

For the *IDN? message, see the separate volume "GPIB, RS-232C interface" operation manual.

When you contact us for any information about the Tester, please indicate the ROM version number and serial number of the Tester. The serial number is shown on the rear panel of the Tester.

The opening screen (Example of ROM version is 1.01)

TOS9200
AC WITHSTANDING VOLTAGE /
INSULATION RESISTANCE TESTER
Ver. 1.01
KIKUSUI ELECTRONICS CORP.

TOS9201
AC/DC WITHSTANDING VOLTAGE /
INSULATION RESISTANCE TESTER
Ver. 1.01
KIKUSUI ELECTRONICS CORP.

To supervisor in charge of operation

- If the operator does not read the language used in this manual, translate the manual into appropriate language.
- Help the operator in understanding this manual before operation.
- Keep this manual near the tester for easy access of the operator.

For your own safety (to avoid electrification)

While the tester is delivering its test voltage, never touch the following areas, or else, you will be electrified, and run the risk of death by electric shock.

- the output terminal
- the test leadwires connected to the output terminal
- the Device Under Test (DUT)
- any part of the tester, which is electrically connected to the output terminal, and
- the same part as above immediately after the output has been cut off when in the DC mode of test.

Also, electric shock or accident may arise in the following cases:

- the tester being operated without grounding.
- if the gloves for electrical job are not used.
- approach to any part connected to the output terminal while the power of the tester is turned on.
- the same action as above immediately after the power of tester has been turned off when in the DC mode of test.

Power Requirements of this Product

Power requirements of this product have been changed and the relevant sections of the Operation Manual should be revised accordingly.

(Revision should be applied to items indicated by a check mark)

Input voltage

The input voltage of this product is _____ VAC,
and the voltage range is _____ to _____ VAC. Use the product within this range only.

Input fuse

The rating of this product's input fuse is _____ A, _____ VAC, and _____ .

-
- ⚠ WARNING**
- To avoid electrical shock, always disconnect the AC power cord or turn off the switch on the switchboard before attempting to check or replace the fuse.
 - Use a fuse element having a shape, rating, and characteristics suitable for this product. The use of a fuse with a different rating or one that short circuits the fuse holder may result in fire, electric shock, or irreparable damage.
-

Safety Symbols

For the safe use and safe maintenance of this product, the following symbols are used throughout this manual and on the product. Understand the meanings of the symbols and observe the instructions they indicate (the choice of symbols used depends on the products).



Indicates that a high voltage (over 1000 V) is used here. Touching the part causes a possibly fatal electric shock. If physical contact is required by your work, start work only after you make sure that no voltage is output here.

DANGER

Indicates an imminently hazardous situation which, if ignored, will result in death or serious injury.



Indicates a potentially hazardous situation which, if ignored, could result in death or serious injury.



Indicates a potentially hazardous situation which, if ignored, may result in damage to the product and other property.



Shows that the act indicated is prohibited.



Is placed before the sign “DANGER,” “WARNING,” or “CAUTION” to emphasize these. When this symbol is marked on the product, see the relevant sections in this manual.



Indicates a protective conductor terminal.



Indicates a chassis(frame) terminal.



Safety Precautions

The following safety precautions must be observed to avoid fire hazard, electrical shock, accidents, and other failures. Keep them in mind and make sure that all of them are observed properly. Using the product in a manner that is not specified in this manual may impair the protection functions provided by the product.



Users

- This product must be used only by qualified personnel who understand the contents of this operation manual.
- If it is handled by disqualified personnel, personal injury may result. Be sure to handle it under supervision of qualified personnel (those who have electrical knowledge.)
- This product is not designed or manufactured for general home or consumer use.

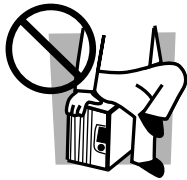

Purposes of use

- Do not use the product for purposes other than those described in the operation manual.

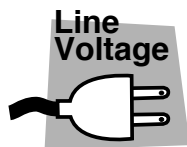

Input power

- Use the product with the specified input power voltage.
- For applying power, use the AC power cord provided. Note that the provided power cord is not use with some products that can switch among different input power voltages or use 100 V and 200 V without switching between them. In such a case, use an appropriate power cord.



Fuse

- With products with a fuse holder on the exterior surface, the fuse can be replaced with a new one. When replacing a fuse, use the one which has appropriate shape, ratings, and specifications.

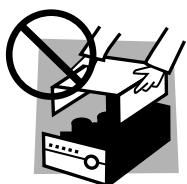

Cover

- There are parts inside the product which may cause physical hazards. Do not remove the external cover.

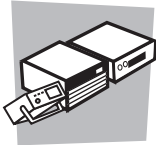

Installation

- When installing products be sure to observe "Precautions for Installation" described in this manual.
- To avoid electrical shock, connect the protective ground terminal to electrical ground (safety ground).
- When installing products with casters, be sure to lock the casters.



Relocation

- Turn off the power switch and then disconnect all cables when relocating the product.
- Use two or more persons when relocating the product which weights more than 18 kg. The weight of the products can be found on the rear panel of the product and/or in this operation manual.
- Use extra precautions such as using more people when relocating into or out of present locations including inclines or steps. Also handle carefully when relocating tall products as they can fall over easily.
- Be sure the operation manual be included when the product is relocated.



Operation

- Check that the AC input voltage setting and the fuse rating are satisfied and that there is no abnormality on the surface of the AC power cord. Be sure to unplug the AC power cord.
- If any abnormality or failure is detected in the products, stop using it immediately. Unplug the AC power cord. Be careful not to allow the product to be used before it is completely repaired.
- Do not disassemble or modify the product. If it must be modified, contact Kikusui distributor/agent.



Maintenance and checking

- To avoid electrical shock, be absolutely sure to unplug the AC power cord before performing maintenance or checking.
- Do not remove the cover when performing maintenance or checking.
- To maintain performance and safe operation of the product, it is recommended that periodic maintenance, checking, cleaning, and calibration be performed.



Service

- Internal service is to be done by Kikusui service engineers. If the product must be adjusted or repaired, contact Kikusui distributor/agent.

Front panel and Rear panel

- Before using the tester, be sure to read Chapter2 "Precautions on Handling"

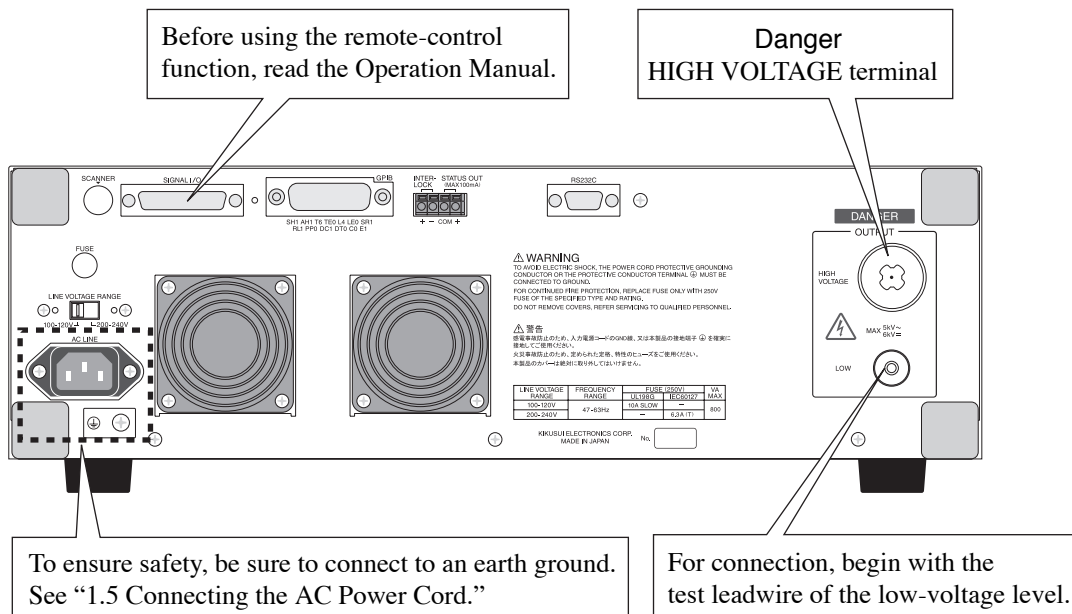
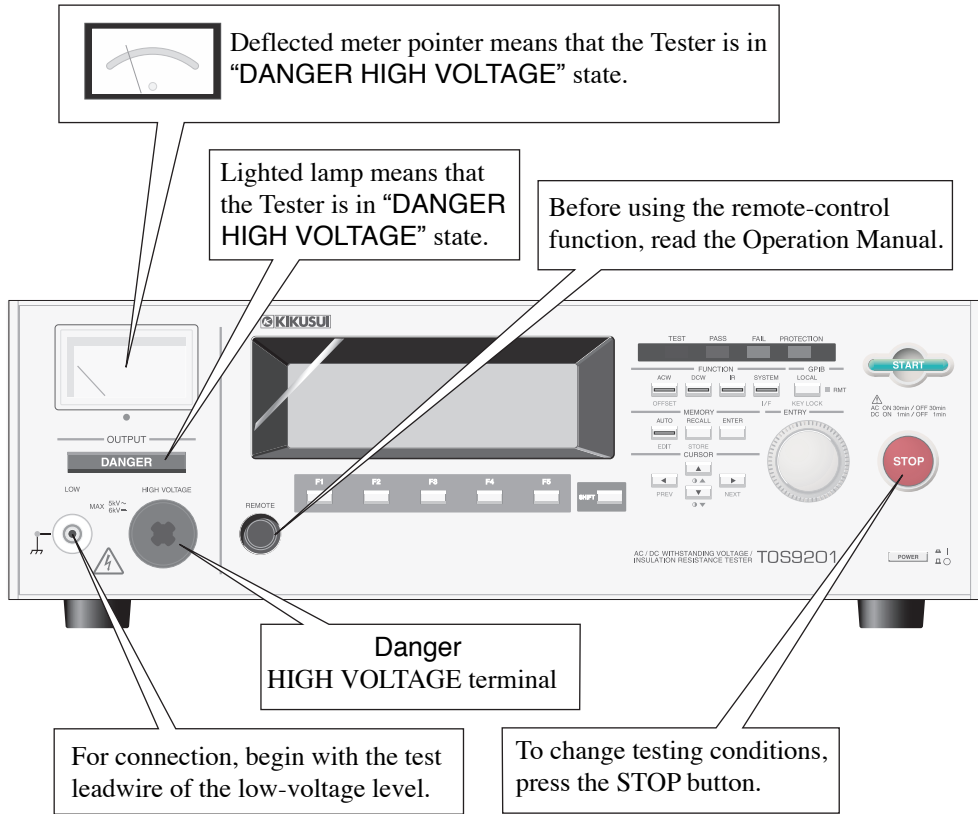

Contents

Safety Symbols - - - - -	IV
Safety Precautions - - - - -	V

Preface

Outline - - - - -	P-1
Features - - - - -	P-2
Options - - - - -	P-7

Chapter 1 Setup

1.1	Unpacking - - - - -	1-1
1.2	Precautions for Installation - - - - -	1-3
1.3	Precautions for Moving - - - - -	1-4
1.4	Checking the Line voltage and Fuse - - - - -	1-5
1.4.1	Switching source voltages - - - - -	1-5
1.4.2	Checking and replacing fuses - - - - -	1-6
1.5	Connecting the AC Power Cord - - - - -	1-7
1.6	Checking Operations - - - - -	1-9

Chapter 2 Precautions on Handling

2.1	Prohibited Operations - - - - -	2-1
2.2	Action When in Emergency - - - - -	2-2
2.3	Precautions on Testing - - - - -	2-2
2.4	Warning for Residual High Voltages - - - - -	2-4
2.5	Dangerous States of Failed Tester - - - - -	2-5
2.6	To Ensure Long-Term Use Without Failures - - - - -	2-5
2.7	Daily Checking - - - - -	2-6

Chapter 3 Basic Operations

3.1	Turning on the Power - - - - -	3-1
3.2	Pre-Test Zero Adjustment - - - - -	3-2
3.3	Structure of LCD Screen - - - - -	3-3
3.4	Settings for AC Withstanding Voltage Testing - - - - -	3-4
3.4.1	Settings on the ACW1 Screen - - - - -	3-5
3.4.2	Settings on the ACW2 screen - - - - -	3-11
3.4.3	Settings on the ACW3 screen - - - - -	3-18
3.5	Settings for DC Withstanding Voltage Testing (TOS9201 only) - - - - -	3-20
3.5.1	Settings on the DCW1 screen - - - - -	3-21
3.5.2	Settings on the DCW2 screen - - - - -	3-25
3.5.3	Settings on the DCW3 screen - - - - -	3-30

3.6	Settings for Insulation Resistance Testing	3-32
3.6.1	Settings on the IR1 screen	3-33
3.6.2	Settings on the IR2 screen	3-38
3.6.3	Settings on the IR3 screen	3-42
3.7	Connecting the Test Leadwire	3-44
3.7.1	Connecting the test leadwire to the tester	3-44
3.7.2	Connecting a DUT	3-44
3.8	Starting and Ending a Test	3-46
3.8.1	Starting a test	3-46
3.8.2	Ending the test	3-49
3.9	Offset Cancel Function	3-53
3.10	System Settings	3-55
3.10.1	SYSTEM 1	3-56
3.10.2	SYSTEM2	3-58
3.10.3	SYSTEM3	3-59
3.10.4	SYSTEM4	3-60
3.11	Interface Settings	3-61
3.12	Panel Memory	3-62
3.12.1	Storage in the panel memory	3-64
3.12.2	Recalling panel memory	3-64
3.13	Program	3-65
3.13.1	Creating and editing a program	3-66
3.13.2	Executing a program	3-68
3.13.3	Suspending the program	3-69
3.13.4	Judgement on the program	3-69
3.13.5	Exiting the program	3-69
3.14	Key Lock	3-69
3.15	Invalid Settings	3-70
3.16	Protection	3-71
3.17	Initialization	3-76

Chapter 4 Using Terminals and Connectors

4.1	REMOTE Terminal	4-2
4.2	SIGNAL I/O Connector	4-4
4.2.1	Specifications for the SIGNAL I/O connector	4-5
4.2.2	Example	4-6
4.2.3	Starting a test	4-8
4.2.4	Recalling the panel memory and programs	4-9
4.3	INTERLOCK Connector	4-11
4.4	STATUS OUT Connector	4-13

Chapter 5 Controlling the TOS6200

5.1	Pre-Control Preparation	5-1
-----	-------------------------	-----

5.1.1	Connection and startup procedure	5-1
5.1.2	Settings on the TOS6200	5-1
5.1.3	Settings on the TOS9200	5-2
5.2	Starting a Test	5-4
5.3	Test Judgement	5-5
5.4	Canceling the TOS6200 Control Mode	5-6

Chapter 6 Part names and Functions

6.1	Front Panel	6-1
6.2	Rear Panel	6-6

Chapter 7 Maintenance

7.1	Cleaning	7-1
7.2	Inspection	7-1
7.3	Maintenance	7-2
7.4	Calibration	7-2
7.5	Troubleshooting	7-3

Chapter 8 Specifications

	Withstanding Voltage test mode	8-1
	Insulation Resistance Testing Mode	8-6
	Interface and Other Functions (TOS9200/TOS9201)	8-9
	General Specifications (TOS9200/TOS9201)	8-12
	Dimensions	8-13

Appendix

1.	Operating Principle	A-1
2.	ASCII Code 20H to 7EH	A-4

	Index	I-1
--	-------	-----

Preface

Outline

The TOS9200 and TOS9201 are withstanding voltage/insulation resistance testers. The TOS9200 can perform AC withstanding voltage testing and insulation resistance testing. The TOS9201 can perform DC withstanding voltage testing, in addition to AC withstanding voltage testing and insulation resistance testing. Both can operate at up to 5 kVAC/100 mA (for up to 30 minutes) in AC withstanding voltage testing, and up to 6 kVDC (at a maximum output of 50 W for up to 1 minute) in DC withstanding voltage testing. These models are capable of performing withstanding voltage testing on electronic equipment and components in accordance with safety standards, including IEC, EN, VDE, BS, UL, CSA, JIS, and the Electrical Appliance and Material Safety Law (in Japan.)

The high-voltage block features a high-efficiency switching power supply and a PWM-based switching amplifier. This ensures high and stable output extremely resistant to power-supply and load fluctuations. The TOS9200 and TOS9201 are almost 30% smaller and lighter than Kikusui's previous models.

For insulation resistance testing, these testers are compatible with 25 V to 1000 V (at a resolution of 1 V) and 0.01 M Ω to 9.99 G Ω (at a maximum rated current of 1 mA to 50 nA).

Once connected to a DUT, the TOS9200 and TOS9201 can not only perform AC withstanding voltage tests, DC withstanding voltage tests, and insulation resistance tests separately, but can also conduct these tests consecutively using the program function. When combined with the high-voltage scanner TOS9221/TOS9220, each tester can operate using four channels. The tester can be connected to four scanners, thus permitting the connection of a total of 16 channels. Further, when used together with the earth continuity tester TOS6200, the TOS9200 and TOS9201 can also be applied to safety tests such as earth continuity tests.

The TOS9200 and TOS9201 are equipped with GPIB and RS-232C as standard features, making them highly applicable to a variety of automatic testing systems that require greater safety and reliability.

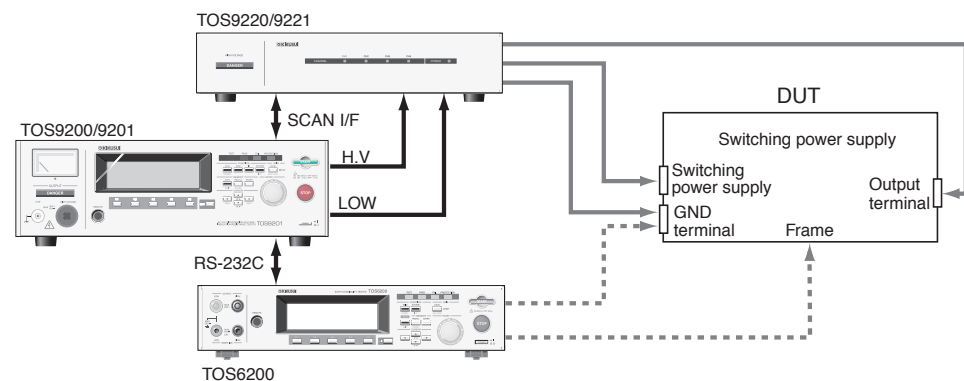

Fig.P-1 Example of system application 1

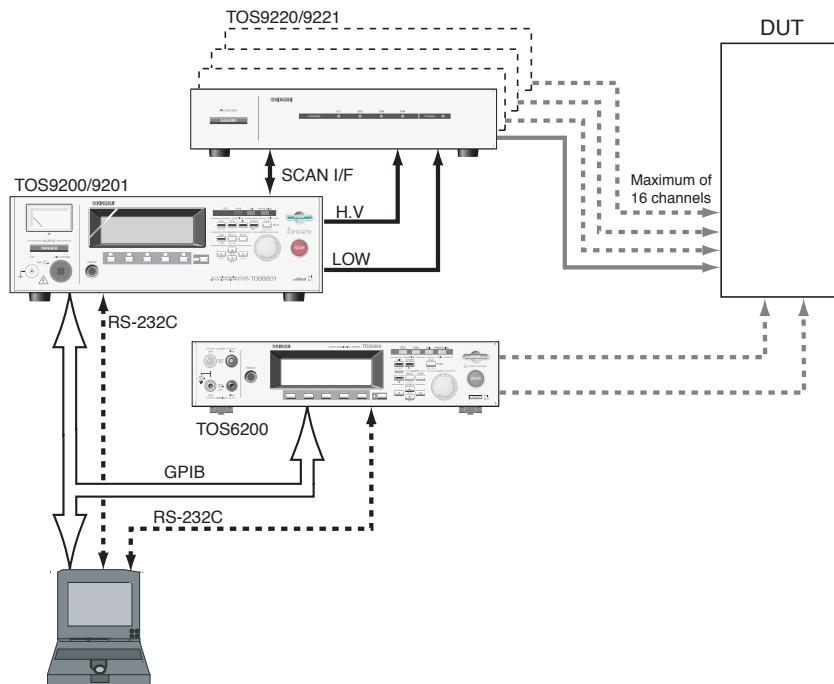

Fig.P-2 Example of system application 2

Features

■ Three testing functions – AC withstanding voltage, DC withstanding voltage, and insulation resistance tests

The TOS9200 performs AC withstanding voltage testing and insulation resistance testing. The TOS9201 conducts AC withstanding voltage testing, DC withstanding voltage testing, and insulation resistance testing.

When connected to a DUT, the tester can perform these three different tests consecutively.

■ AC withstanding voltage test at 5 kV/100 mA

The high-voltage power block is equipped with a high-efficiency switching power supply, a PWM-based switching amplifier, and a high-voltage 500 VA transformer, realizing a maximum output of 5 kV/100 mA (up to 30 minutes), 2.5 times that of Kikusui's former counterparts. For an upper limit of 100 mA or more at a test voltage of at least 500 V, the TOS9200 and TOS9201 conform, though only for an instant, to IEC requirements for short-circuit current of 200 mA or more. (The testers do not allow continuous output, as the output is cut off when an overcurrent is detected.) In addition, these testers generate a consistent test voltage of 50 Hz/60 Hz, independently of the power voltage, and contain the voltage regulation to less than $\pm 3\%$. This makes it unnecessary to readjust the output voltage when a test voltage has been preset.

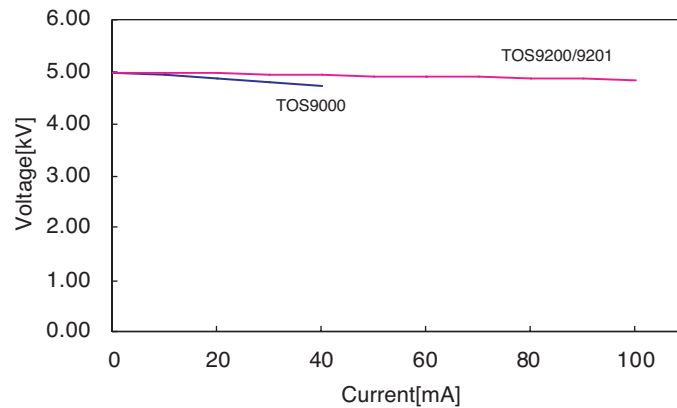

Fig.P-3 ACW Load Regulation

■ DC withstanding voltage test at 6 kV (maximum output of 50 W)

The TOS9201 can perform DC withstanding voltage tests for a wide voltage range of up to 6 kV (maximum output of 50 W and maximum duration of 1 minute). The tester is equipped with a stable, low-ripple DC/DC converter with a voltage regulation of 1 % or less.

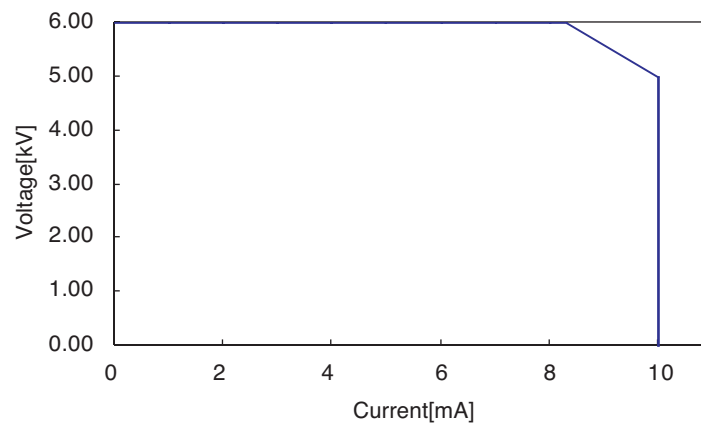

Fig.P-4 DCW Output Voltage Range

■ Insulation resistance test at 25 V to 1000 V (resolution of 1 V)/ 0.01 MΩ to 9.99 GΩ (in a range from a maximum rated current of 1 mA to 50 nA)

The test voltage ranges from 25 V to 1000 V at a resolution of 1 V, with a wide resistance measuring range of 0.01 MΩ to 9.99 GΩ.

Test voltage	Resistance measuring range
25 V	0.03 MΩ - 500 MΩ
50 V	0.05 MΩ - 1.00 GΩ
100 V	0.10 MΩ - 2.00 GΩ
125 V	0.13 MΩ - 2.50 GΩ
250 V	0.25 MΩ - 5.00 GΩ
500 V	0.50 MΩ - 9.99 GΩ
1 000 V	1.00 MΩ - 9.99 G

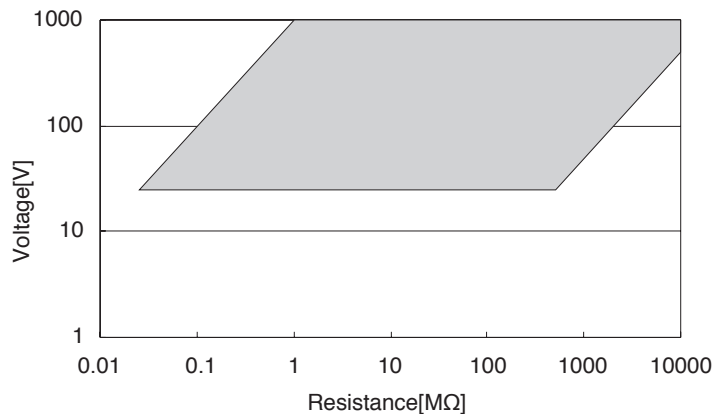

Fig.P-5 IR Measurement Range

■ Fully programmable GPIB and RS-232C interfaces as a standard feature

All functions except for the POWER switch, KEYLOCK, and program execute (AUTO) functions, are remote-controllable. Test conditions such as the test voltage, judgement value, and test time can be controlled remotely in AC and DC withstanding voltage and insulation resistance tests. Measured values and measurement results can also be read back by remote control. The GPIB and RS-232C interfaces provided as a standard feature smoothly interface the tester with a PC, sequencer, and other devices.

■ Flexible control function realized by a high-voltage scanner

When combined with the optional high-voltage scanner TOS9220 (5 kVAC/6 kVDC), the TOS9200/9201 can test multiple points in withstanding voltage and insulation resistance tests. Using the TOS9200/TOS9201 panel, each channel can be set to a HI/LO/OPEN voltage. One scanner can operate up to four channels. Up to four scanners can be connected to the TOS9200/9201, enabling the simultaneous operation of a total of 16 channels. The TOS9221 is equipped with a function for detecting connections between the high-voltage test leadwire and the DUT, thus ensuring highly reliable testing.

■ Rise-time control function

In AC withstanding voltage testing, DC withstanding voltage testing, and insulation resistance testing, a voltage can be slowly increased until it reaches a required test value, instead of applying the required test voltage to the DUT immediately after the start of a test. The voltage rise time can be set to 0.1 s through 99.9 s at a resolution of 0.1 s, and to 100 s through 200 s at a resolution of 1 s. The start voltage, which is applied at the start of a test, can be set to 0 % to 99 % of the test voltage at a resolution of 1 %. Thus, the TOS9200/TOS9201 conforms to the requirement for the type certification test under the UL standard and the withstanding voltage test under the IEC standard that less than half of the test voltage be applied initially and slowly increased for a specified period of time before the test voltage is reached.

■ Fall-time control function

For PASS judgement in AC withstanding voltage testing, the test voltage can be decreased in increments. The voltage fall time can be set to 0.0 s through 99.9 s at a resolution of 0.1 s and to 100 s through 200 s at a resolution of 0.1 s.

■ Discharge function

Generally, DUTs contain capacitive elements. Therefore, DUTs remain charged immediately after a DC withstanding voltage test or insulation resistance test has been conducted, resulting in the danger of electric shock. The TOS9200/TOS9201 has a function for forcibly discharging the DUT upon completion of DC withstanding voltage test or insulation resistance test.

■ Enhanced safety

To enhance safety, the TOS9200/TOS9201 is equipped with a number of devices and safety functions, including safe output terminals, a discharge function, and an analog voltmeter that constantly monitor the output-terminal voltages. Such safety measures also include a danger lamp that constantly monitors output-terminal voltages even when no test is under way and lights up when a voltage is detected, in addition to an interlock function that cuts off output in coordination with an external device.

■ Improved measurement accuracy

The TOS9200/TOS9201 is equipped with a digital voltmeter for withstanding voltage testing with an accuracy of $\pm(1\% \text{ of the reading} + 30 \text{ V})$, and another for insulation resistance testing with an accuracy of $\pm(1\% \text{ of the reading} + 1 \text{ V})$. The two voltmeters display measured values not only during a test but also during execution of a program.

The testers are equipped with an ammeter for withstanding voltage testing that features accuracy of $\pm(1\% \text{ of the reading} + 20 \text{ }\mu\text{A})$. Kikusui's previous testers had a measurement resolution of approximately 1 mA and an accuracy of approximately $\pm 5\%$ of the upper current that was set to 100 mA. By comparison, the TOS9200/TOS9201 can operate with an accuracy of $\pm(3\% \text{ of the reading} + 20 \text{ }\mu\text{A})$ at an upper current of 100 mA. The two ammeters display measured values not only during a test but also during execution of a program.

■ Offset cancel function

In an AC withstanding voltage test that requires high sensitivity and high voltage, current flowing into the stray capacity of test leadwires and jigs tends to cause measurement errors. The TOS9200/TOS9201 features an offset cancel function that cancels offset currents such as stray currents.

■ Voltage hold function

During judgement, this function allows the tester to retain measured voltages recorded upon completion of a test, while it is still outputting the judgement results. Combined with the rise-time control function, the voltage hold function enables detection of the dielectric breakdown voltage.

■ Output voltage monitoring function

When the output voltage deviates from \pm (10 % of the setting +50 V), the monitoring function activates to suspend the test, ensuring highly reliable testing.

■ High operability

The TOS9200/TOS9201 is easy to operate, allowing the operator to start using it without difficulty. Featuring the TOS5000's high operability, the tester displays the primary test conditions on the first page of the menu, with the secondary test conditions shown on the following pages. To set test conditions, simply use the cursor key to choose from among the items displayed on the LCD, and then turn the rotary knob. The function keys allow you to jump to items to be set. During a test, the output voltage can be changed using the rotary knob.

■ Saving 100 test conditions for each test

One hundred test conditions, such as the test voltage, judgement value, and test time, can be set and named for each test of the AC withstanding voltage, DC withstanding voltage, and insulation resistance. For example, the name of the applicable safety standard and the shipment destination of the DUT can be saved. Even when a change is made to the destination of a product or the name of the applicable safety standard, there is no need to change the preset test conditions. To recall these test conditions, simply set the memory number. If such test conditions have their own name, they can be confirmed using that name. Test conditions can even be recalled from outside.

■ Programmed test conditions

By configuring the test conditions saved for each test, 100 test steps can be performed consecutively.

When used together with the earth continuity tester TOS6200, the TOS9200/TOS9201 integrates the test conditions saved in the earth continuity tester to perform continuous tests. Tests can be performed easily, such as on the AC withstanding voltage, insulation resistance, DC withstanding voltage, and earth continuity, in that order.

Up to 500 steps can be configured, with 100 programs storable, permitting recalls even from outside.

■ Remote-control function and signal output function

Used exclusively for options, the DIN connector on the front panel enables the remote control of start/stop operations, like its conventional counterpart. Using the SIGNAL I/O connector on the rear panel, start/stop operations can be conducted and the panel memory or program memory can be recalled.

Seven signals are output by the open collector through the SIGNAL I/O connector – HV ON, TEST, PASS, UPPER FAIL, LOWER FAIL, READY, and PROTECTION. These signals can be used together with the remote-control function to automate testing and save labor.

■ High-voltage output terminal on the rear panel

The rear panel includes a high-voltage output terminal to be used for an optional high-voltage scanner. This terminal also facilitates wiring when you mount the tester on a rack.

■ Small and lightweight

For AC withstanding voltage testing, the TOS9200/TOS9201 is provided with an output power supply 2.5 times that of Kikusui's conventional testers, in addition to DC withstanding voltage and insulation resistance testing mechanisms. Nevertheless, its body is 30 % smaller in both size and weight than that of Kikusui's conventional models.



- **WARNING** This tester handles a high voltage of 5 kVAC/6 kVDC. Therefore, do not touch the DUT or cables, as electric shock may result.

Around the DUT, provide full safety measures such as an enclosure to keep workers away. In addition, to ensure safety, exercise extreme care to prevent the output of a high voltage due to improper connections and operations.

Options

The following options are available for this tester:

■ RC01-TOS/RC02-TOS remote-control box

This remote-control box is used for remote control of the start/stop operations of this tester. It is connected to the REMOTE terminal on the front panel.

The RC01-TOS has one START switch. The RC02-TOS has two START switches, and starts operation only when both are pressed simultaneously.

Function

OPERATE switch

The TEST-switch operation is effective only when the OPERATE switch is on. Operation is forcibly stopped when the switch is turned off.

START switch

This switch starts a test only when the OPERATE switch is on and in the ready status.

STOP switch

This switch is used to cut off the output voltage and cancel the FAIL status. It performs the same function as the STOP switch on the front panel.

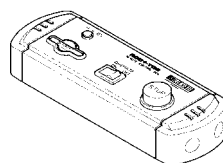

RC01-TOS: 200mm (W) x 70 mm(H) x 39mm (D)

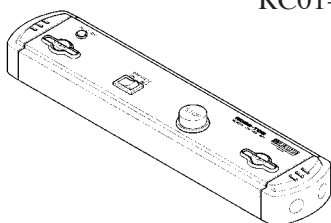

RC02-TOS: 330mm (W) x 70mm (H) x 39mm (D)

■ High-voltage test probe HP01A-TOS/HP02A-TOS

This test probe is connected to Kikusui's withstanding voltage tester to output a test voltage. It is designed to prevent the unintended output of a test voltage.

To output a test voltage, hold the slide lever on the test-probe grip and pull the trigger with one hand, then press the switch on top of the probe using the other hand.

When you release either hand, the STOP signal is output and the test voltage is cut off.

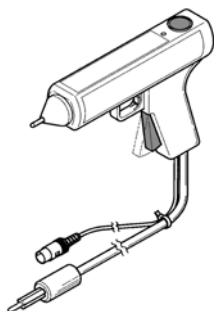

Maximum working voltage

AC 4 kV (rms) 50 Hz/60 Hz

DC 5 kV

Cable length

HP01A-TOS: Approximately 1.8 m

HP02A-TOS: Approximately 3.5 m

Fig.P-6 High-voltage test probe

-
- ⚠ WARNING**
- This probe is designed for a maximum working voltage of 4 kVAC/5 kVDC. It is dangerous to apply a voltage exceeding this level. Be sure to use this probe at a test voltage below the maximum working voltage.
 - Do not connect this probe to the DUT when a test voltage is being output from the probe. In addition, do not cut off the connection to the DUT when a test voltage is being output from the probe.

If the connection between the probe and the DUT is cut off while a high voltage is being output from the probe, the DUT may be damaged. In addition, the DUT remains charged, making it extremely dangerous.

Therefore, connect the probe to a DUT before starting a test, be sure to confirm that the LED on the probe is off before ending a test, and then disconnect the DUT from the probe.

-
- ⚠ CAUTION** • To conduct a test under the UL standard using this probe, turn on the FAIL MODE function on the tester. When this function is on, the tester performs the next action to allow the FAIL status to be checked.

When the test ends in the FAIL status, the status is not cancelled even when you release your hand from the probe. To cancel the FAIL status, press the STOP switch on the tester. For settings, see "FAIL MODE" in "3.10 System Settings".

■ High-voltage scanner

The high-voltage scanner TOS9220/TOS9221 has a function to distribute a test voltage supplied by the tester among multiple test points.

- A single high-voltage scanner distributes an output to four channels. Each channel can be set to a different electric-potential level – HIGH, LOW, or OPEN. AC/DC testing and insulation resistance testing can be conducted at any of four test points.
- Up to four scanners can be connected to one tester, enabling expansion to a maximum of 16 channels.
- The contact between the output on each channel and a test point can be checked (the contact check function is provided for the TOS9221 scanner only).

These features ensure highly reliable, labor-saving withstanding voltage and insulation resistance tests on electric and electronic devices and components having multiple test points.

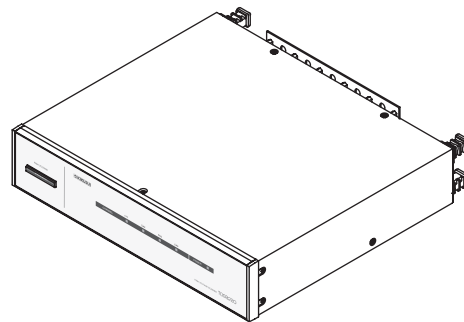

Fig.P-7 High-voltage scanner TOS9220/TOS9221



This chapter describes the procedures from unpacking to installation to operation checking.

1.1 Unpacking

Upon receiving the product, confirm that the necessary accessories are included and have not been damaged in transit. Should any damage or shortage be found, please contact Kikusui distributor/agent.

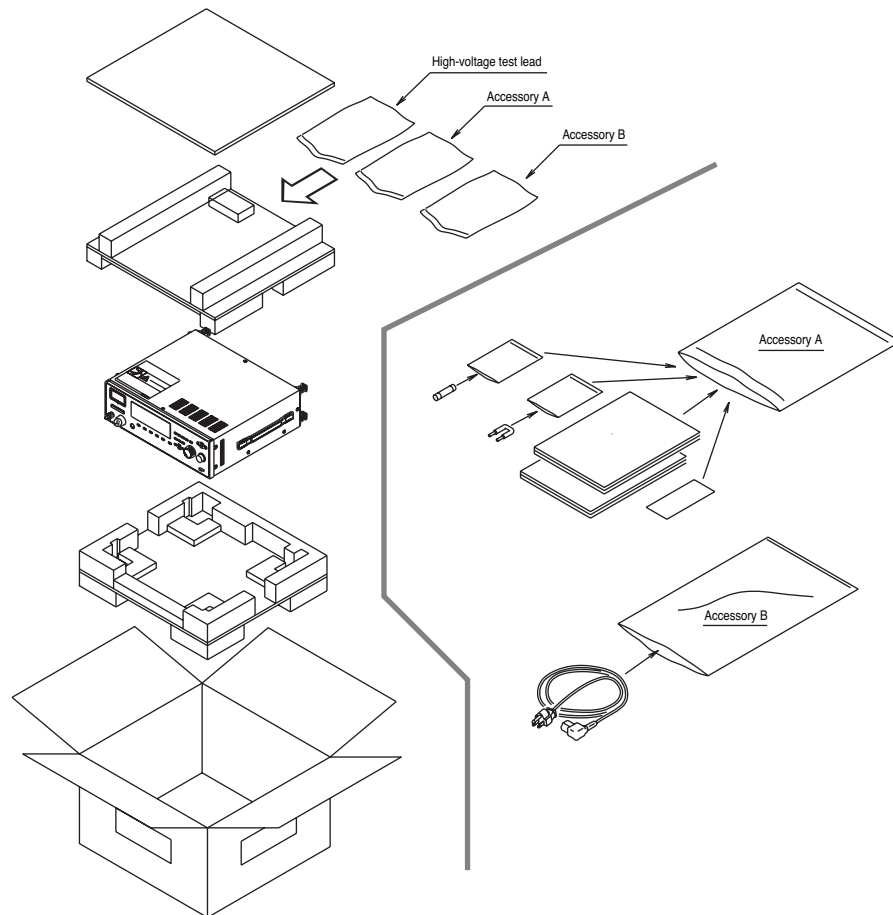
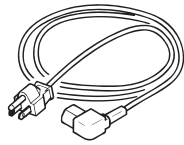

Fig.1-1 Packing/unpacking

NOTE

- Retain the packing material for future transport.



or



or

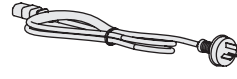

Rating: 125 Vac/10 A
PLUG: NEMA5-15
[85-AA-0003]

Rating: 250 Vac/10 A
PLUG: CEE7/7
[85-10-1070]

Rating: 250 Vac/10 A
PLUG: GB1002
[85-10-0790]

- AC power cord (1 pc.)
2.5 m

The power cord that is provided varies depending on the destination for the product at the factory-shipment.

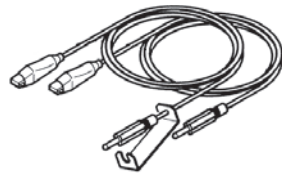

- TL01-TOS High-voltage test leadwires (1 set)
1.5 m
[82970]



- "DANGER HIGH VOLTAGE" sticker (1 sheet)
[A8-210-202]

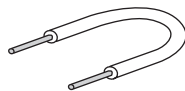

- Interlock jumper (1 pc.)
[91-82-1511]



The fuse that is provided varies depending on the destination for the product at the factory-shipment.

- Spare fuse (1 pc.)
10 A, 250 V [99-02-0031]
or 6.3 A, 250 V [99-02-0019]

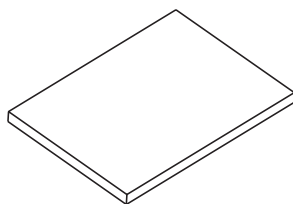

- Tester Operation Manual (1 copy)
[Z1-002-412]

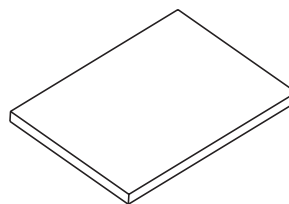

- GPIB, RS-232C Operation Manual (1 copy)
[Z1-002-422]

Fig.1-2 List of accessories

NOTE

- Place the "DANGER HIGH VOLTAGE" sticker in a visible location near the tester or installation site.

The product does not include a SIGNAL I/O cable, GPIB interface cable, or RS-232C interface cable. Users are requested to procure them on their own.

1.2 Precautions for Installation

Be sure to observe the following precautions when installing the tester.

■ Do not use the tester in a flammable atmosphere.

To prevent explosion or fire, do not use the tester near alcohol, thinner, or other combustible materials, or in an atmosphere containing such vapors.

■ Avoid locations where the tester is exposed to high temperatures or direct sunlight.

Do not locate the tester near a heater or in areas subject to drastic temperature changes.

Operating temperature range: +5 °C to +35 °C (+41 °F to +95 °F)

Storage temperature range: -20 °C to +70 °C (-4 °F to +158 °F)

■ Avoid humid environments.

Do not locate the tester in a high-humidity environment—near a boiler, humidifier, or water supply.

Operating humidity range: 20 % to 80 % RH
(no dew condensation permitted)

Storage humidity range: 90 % RH or less
(no dew condensation permitted)

Condensation may occur even within the operating humidity range. In that case, do not start using the tester until the location is completely dry.

■ Do not place the tester in a corrosive atmosphere.

Do not install the tester in a corrosive atmosphere or one containing sulfuric acid mist or the like. This may cause corrosion of various conductors and imperfect contact with connectors, leading to malfunction and failure, or in the worst case, a fire.

■ Do not locate the tester in a dusty environment.

Dirt and dust in the tester may cause electrical shock or fire.

■ Do not use the tester where ventilation is poor.

This tester features a forced-air cooling system. Provide sufficient space for the air inlet on the lateral side and the air outlet on the rear side to allow air to flow.

■ Do not place the tester on a tilted surface or in a location subject to vibrations.

If placed on a non-level surface or in a location subject to vibration, the tester may fall, resulting in damage and injury.

■ Do not use the tester in locations affected by strong magnetic or electric fields.

Operation in a location subject to magnetic or electric fields may cause the tester to malfunction, resulting in electrical shock or fire.

■ Do not use the tester in locations near a sensitive measuring instrument or receiver.

Operation in a location subject, may cause such equipment may be affected by noise generated by the tester. At a test voltage exceeding 3 kV, corona discharge may be generated to produce substantial amounts of RF broadband emissions between grips on the test leadwire. To minimize this effect, secure a sufficient distance between alligator clips.

In addition, keep the alligator clips and test leadwire away from the surfaces of conductors (particularly sharp metal ends).

■ Secure adequate space around the power plug.

Do not insert the power plug to an outlet where accessibility to the plug is poor. And, do not place objects near the outlet that would result in poor accessibility to the plug.

■ Use the product in an industrial environment.

This product may cause interference if used in residential areas. Such use must be avoided unless the user takes special measures to reduce electromagnetic emissions to prevent interference to the reception of radio and television broadcasts.

1.3 Precautions for Moving

When moving the tester to the installation site or otherwise transporting it, take the following precautions:

■ Before moving the tester, turn off the power switch.

Transporting the tester with its POWER switch on can lead to electric shock and damage.

■ When moving the tester, Disconnect all wires from it.

Moving the tester without disconnecting the cables may result in breakage of the wire or injury due to the tester tipping over.

■ For transportation, use the special packing material for the tester.

Transport the tester in its original package to prevent vibration and falls, which may damage the tester. If you require packing material, contact Kikusui distributor/agent.

1.4 Checking the Line voltage and Fuse

1.4.1 Switching source voltages

-
- ⚠ WARNING**
- This instrument is designed to operate from the overvoltage category II. Do not operate it from the overvoltage category III or IV.
 - Before turning on the power, make sure of the fuse and the source voltage agree with the LINE-VOLTAGE RANGE switch on the rear panel.

Nominal voltage range (allowable voltage range):

100 V to 120 V AC (85 V to 132 V AC)

200 V to 240 V AC (170 V to 250 V AC)

Allowable frequency range: 47 Hz to 63 Hz

- ⚠ CAUTION**
- To prevent malfunctions, be sure to operate within the line-voltage range.
-

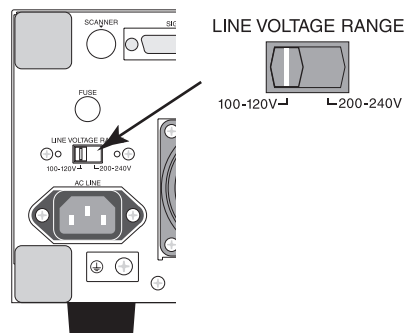

Fig.1-3 LINE-VOLTAGE RANGE switch

1.4.2 Checking and replacing fuses

- ⚠ WARNING**
- To prevent electric shock, before checking or replacing the fuse, be sure to turn off the POWER switch and unplug the AC power cord.
 - Make sure that the fuse used conforms to the instrument specifications, including shape, rating, and characteristics. Using a fuse with different rating or short-circuiting, the fuse holder will damage the instrument.

1. Turn off the POWER switch, and unplug the AC power cord.
2. On the rear panel, remove the fuse holder, as shown in Fig. 1-4, by pushing it inward and unscrewing it counterclockwise using a screwdriver.

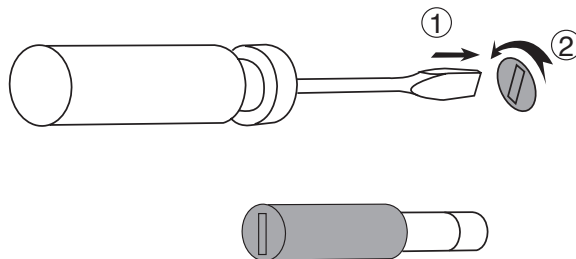

Fig.1-4 Removing the fuse holder

3. In accordance with the fuse rating specified below, check the fuse type and replace the fuse.
4. Following the above steps in the reverse order, reinstall the fuse holder.

■ Fuse rating

LINE VOLTAGE RANGE	FREQUENCY RANGE	FUSE (250V)		VA MAX
		UL198G	IEC60127	
100-120V	47-63Hz	10A SLOW	—	800
200-240V		—	6.3A (T)	

- NOTE**
- The pre-arcing time-current characteristic of fuses are named differently in the UL and IEC standards. Use fuses conforming to both or either of the standards.

1.5 Connecting the AC Power Cord

-
- ⚠ WARNING**
- This product is an IEC Safety Class I equipment (equipment with a protective conductor terminal). To prevent electric shock, be sure to ground (earth) the unit.
 - This product is grounded through the ground wire of the power cord. Be sure to connect the power plug to an outlet with an appropriate earth ground.
-

- NOTE**
- Use the supplied power cord to connect to the AC line. If the supplied power cord cannot be used due to the rated voltage or the plug shape, have the cord replaced with an appropriate power cord of length 3 m or less by a qualified engineer. If obtaining a power cord is difficult, consult your Kikusui agent or distributor.
 - The power cord with a plug may be used to disconnect the product from the AC line in an emergency. Connect the plug to an easily accessible power outlet so that the plug can be removed from the outlet at any time. Be sure to allow enough space around the power outlet.
 - Do not use the supplied power cord on other instruments.
-

This product is an equipment of IEC Overvoltage Category II (energy-consuming equipment supplied from the fixed installation).

1. Turn the POWER switch off.
2. Check that the AC power line complies with the input rating of the tester.
See "1.4 Checking the Line voltage and Fuse".
3. Connect the power cord to the AC LINE connector on the rear panel, connect the power cord plug to an outlet with proper grounding.

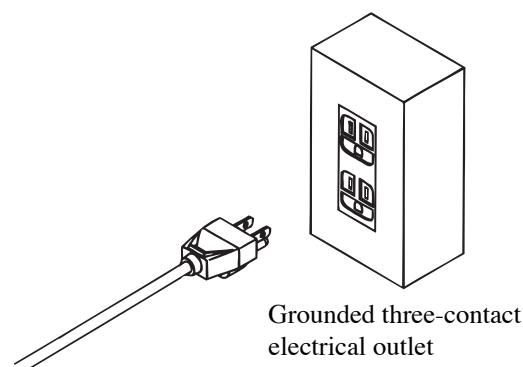

Fig.1-5 Plug connection

When Connecting to an Ungrounded Outlet

If you have to connect the tester to an ungrounded outlet, connect the protective conductor terminal on the rear panel of the tester to an earth ground.

Have specialized engineers select, manufacture, and install cables. To ensure secure connection, use proper tools.

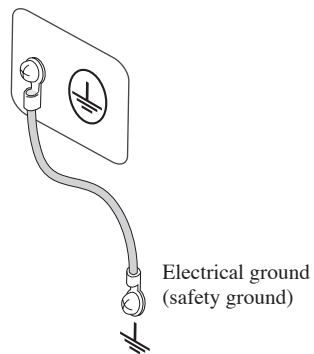

Fig.1-6 Grounding by using the protective conductor terminal

1.6 Checking Operations

This tester does not generate output until the protection status is cancelled by the interlock function. To quickly check operations, connect the interlock jumper (provided with this product) to the INTERLOCK connector.



- **WARNING** Use the interlock jumper only to quickly cancel the protection status.

When using this tester, use the interlock function as much as possible to ensure a safe operating environment. To use jigs in withstanding voltage or insulation resistance testing, provide a cover or other means for the DUT to prevent electric shock by cutting off the output when the cover is opened. It is also recommended that an enclosure be provided around the operating area and that output be cut off every time the door is opened.

For details, see "4.3 INTERLOCK Connector".

- Before turning on the power, confirm that the allowable voltage range indicated on the power supply is the same as that indicated on the rear panel of the tester. For details, see "1.4 Checking the Line voltage and Fuse"
- When the power is turned on, the tester lights all LEDs on the front panel and self-diagnosis is started.

Before starting up the tester, confirm that all LEDs are on to ensure safety. It is particularly dangerous to start a test when the DANGER lamp is broken. Note that, in self-diagnosis, even when the DANGER lamp is lighting, no output or voltage is being generated.



- **CAUTION** After turning off the POWER switch, wait several seconds before turning it on. Turning the POWER switch on/off repeatedly with insufficient intervals may damage the tester.
-

Checking procedure

1. Confirm that the allowable voltage range indicated on the power supply is the same as that indicated on the rear panel.
2. Confirm that the AC power cord is properly connected to the AC LINE connector on the rear panel.
3. Plug in the AC power cord.
4. Turn on the POWER switch. Confirm that all LEDs on the front panel are lit.
5. Following the opening screen, display the ACW screen and confirm that the tester is kept in the PROTECTION status by the interlock function ("INTERLOCK" flickers on the LCD).
6. Turn off the POWER switch.
7. As shown in Fig. 1-7, connect the interlock jumper (provided with the product) to the INTERLOCK connector on the rear panel.
8. Turn on the POWER switch again.

9. Following the opening screen, display the ACW screen and confirm that the tester is kept in the READY status.

The above steps complete the checking procedure.

Connecting the interlock jumper

1. Insert a screwdriver into A to open B.
2. Insert the interlock jumper into B. Confirm that the cable shield is not caught in the jumper.
3. By lightly pulling on the jumper, confirm that it is connected securely.
4. Take the same steps for the positive (+) and negative (-), then short-circuit both sides.

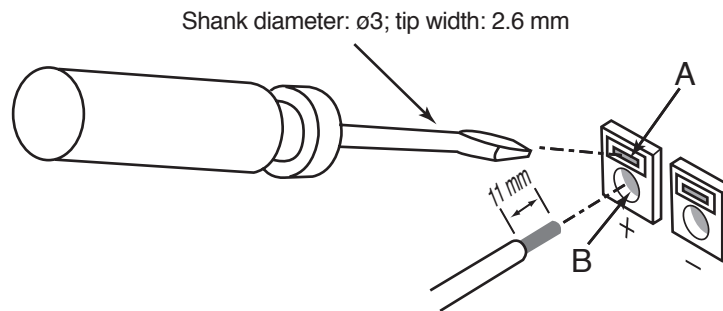

Fig.1-7Connecting the jumper

This chapter describes the precautions to be followed in the handling of this tester. When using the tester, take utmost care to ensure safety.

-
- ⚠ WARNING** • The tester derives a 5 kVAC/6 kVDC test voltage which can cause human injury or death. When operating the tester, be extremely careful and observe the cautions, warnings, and other instructions given in this chapter.
-

2.1 Prohibited Operations

■ Do not turn on/off the power repeatedly

After turning OFF the power switch, be sure to allow several seconds or more before turning it ON again. Do not repeat turning ON/OFF the power switch rapidly –if you do this, the protectors of the tester may not be able to render their protective functions properly. Do not turn OFF the power switch when the tester is delivering its test voltage—you may do this only in case of emergency.

■ Do not short the output to the earth ground

Pay attention so that the high test voltage line is not shorted to a nearby AC line or nearby devices (such as conveyors) which are connected to an earth ground. If it is shorted, the tester chassis can be charged up to the hazardous high voltage.

Be sure to connect the protective grounding terminal of the tester to an earth line. If this has been securely done, even when the HIGH VOLTAGE terminal is shorted to the LOW terminal, the tester will not be damaged and its chassis will not be charged up to the high voltage.

Be sure to use a dedicated tool when grounding the protective grounding terminal. See " • This product is an IEC Safety Class I equipment (equipment with a protective conductor terminal). To prevent electric shock, be sure to ground (earth) the unit."

-
- NOTE** • The term "AC line" here means the line on which the tester is operating. That is the line to whose outlet the AC power cable of the tester is connected. It may be of a commercial AC power line or of a private-generator AC power line.
-

■ Do not apply an External Voltage

Do not apply a voltage from any external device to the output terminals of the tester. The analog voltmeter on the front panel cannot be used as stand-alone voltmeter. They may be damaged if their output terminals are subject to an external voltage.

2.2 Action When in Emergency

In case of an emergency (such as electric shock hazard or burning of DUT), take the following actions. You may do either (a) or (b) first. But be sure to do both.

(a) Turn OFF the power switch of the tester.

(b) Disconnect the AC power cord of the tester from the AC line receptacle.

2.3 Precautions on Testing

■ Wearing Insulation Gloves

When handling the tester, be sure to wear insulation gloves in order to protect yourself against high voltages. If no insulation gloves are available on your market, please order Kikusui distributor/agent for them.

■ Precautions for Pausing Tests

When changing test conditions, press the STOP switch once to take precautions. If you are not going to resume the test soon or if you are leaving the Test area, be sure to turn-OFF the POWER switch.

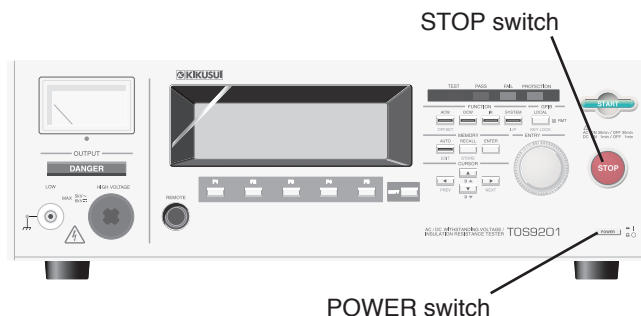

Fig.2-1 Suspending testing and operation

■ Items Charged Up to Dangerous High Voltages

When in test, the DUT, test leadwires, probes, and output terminals and their vicinities can be charged up to dangerous high voltages. Never touch them when in test.

⚠ WARNING • The vinyl sheaths of the alligator clips of the test leadwires which are supplied accompanying the tester have no sufficient insulation for the high test voltages. Never touch them when in test.

Alligator clip
Never touch this part.

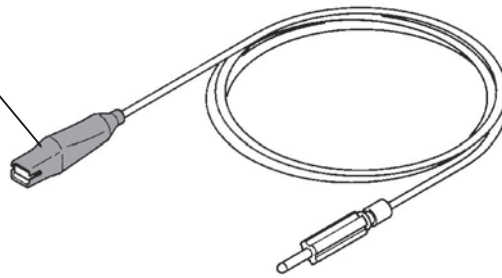

■ Matters to be Sure of After Turning-OFF Power

If you have to touch the DUT, test leadwires, probes, and/or output terminals and their vicinities for re-connections or other reasons, be sure of the following two matters.

- (a) The analog voltmeter indicates “zero.”
- (b) The DANGER lamp has gone out.

■ Warnings for Remote Control

Be extremely careful when operating the tester in the remote control mode in which the dangerous high test voltage is ON/OFF-controlled remotely. Provide protective means as follows:

- Provide means to assure that the test setup does not become the test voltage is being delivered by inadvertent operation.
- Provide means to assure that none can touch the DUT, test leadwires, probes, output terminals and their vicinities when the test voltage is being delivered.

2.4 Warning for Residual High Voltages

⚠ WARNING • In DC withstanding voltage testing and insulation resistance testing, the test leadwire, test probe, and DUT are charged to a high voltage. The tester is equipped with a discharge circuit, but some time is nonetheless required to discharge them after the output is cut off. There is a danger of electric shock during discharge. To avoid electric shock, take the utmost care to ensure that the DUT, test leadwire, probe, and highly charged parts around the output terminal are not touched. If it is necessary to touch them, be sure to confirm both (a) and (b):

- (a) The analog voltmeter indicates “zero.”
- (b) The DANGER lamp has gone out.

- As soon as the output is cut off, the tester’s discharge circuit starts forced discharging. Do not disconnect the DUT during a test or prior to completion of discharging.
-

Discharge time

The length of the discharge time varies according to the properties of the DUT and the test voltage.

Discharge is conducted at a resistance of approximately 125 k Ω in DC withstanding voltage testing, and at 25 k Ω in insulation resistance testing.

When no DUT is connected, the tester itself requires the following lengths of time to reduce the internal capacitor voltage to 30 V.

- Insulation resistance testing at 1000 V: Approximately 0.5 ms
- DC withstanding voltage testing at 6 kV: Approximately 5 ms

Assuming that a 0.05 μ F capacitor is tested, the following lengths of time are required to reduce the charge to 30 V.

- Insulation resistance testing at 1000 V: Approximately 5 ms
- DC withstanding voltage testing at 6 kV: Approximately 40 ms

If the DUT is disconnected during a test or before the completion of discharging, assuming that the DUT has a capacity of 0.01 μ F and a parallel resistance of 100 M Ω , approximately 5.3 seconds at 6 kV and approximately 3.5 seconds at 1 kV are required for the DUT to discharge to 30 V.

When the approximate time constant of the DUT is known, the time required for discharging to 30 V after the output is cut off is calculated as the time constant times the value given above.

2.5 Dangerous States of Failed Tester

Typical possible dangerous states of the tester are as shown below and in which cases the most dangerous situation that **“the high test voltage remains delivered and won't be turned off!”** may occur. When this situation has occurred, immediately turn OFF the power switch and disconnect the AC power cable from the AC line receptacle.

- The DANGER lamp does not go out despite you have pressed the STOP switch.
- The DANGER lamp does not light up despite the pointer of the analog voltmeter is deflected indicating that the output voltage is being delivered.

Also when the tester is in other malfunctioning states than the above, there is a possibility that the output voltage is delivered irrespective of your proper operating procedure. Never use the tester when it has failed.

-
- ⚠ WARNING**
- Keep the tester away of other people until you call our service engineer for help.
 - Immediately call Kikusui distributor/agent. It is hazardous for an unqualified person to attempt to troubleshoot any tester problem.
-

2.6 To Ensure Long-Term Use Without Failures

The withstanding voltage-generating block of the tester is designed to release half the rated amount of heat, in consideration of the size, weight, cost, and other factors of the tester. The tester must therefore be used within the ranges specified below. If you deviate from these ranges, the output block may be heated to excess, activating the internal protection circuit. Should this happen, wait until the temperature returns to the normal level.

Output requirements for withstanding voltage testing

Ambient temperature	Upper current	Pause	Output time	
$t \leq 40 \text{ }^\circ\text{C}$	AC	$50 < i \leq 110 \text{ mA}$	At least as long as the output time	
		$i \leq 50 \text{ mA}$	Not necessary	
	DC	$5 < i \leq 11 \text{ mA}$	At least as long as the output time	Maximum of 1 minute
		$i \leq 5 \text{ mA}$	At least as long as the judgement wait time (WAIT TIME)	Continuous output possible

(Output time = voltage rise time + test time + voltage fall time)

2.7 Daily Checking

To avoid accidents, confirm at least the following before starting operation:

- The tester is connected to an earth ground.
- The coating of the high-voltage test leadwire is free from cracks, fissures, and breakage.
- The high-voltage test leadwire is not broken.
- The tester generates FAIL signal when the ends of the low-voltage test leadwire and high-voltage test leadwire are short-circuited.

This chapter describes the procedures for conducting withstanding voltage and insulation resistance tests.

3.1 Turning on the Power

-
- ⚠ WARNING**
- This tester does not generate output until the protection status is cancelled by the interlock function. The tester can be activated temporarily using the interlock jumper (provided with the product). Before starting a test, read "4.3 INTERLOCK Connector" for the procedure for starting up the tester using the interlock function.
 - Before turning on the power, be sure to confirm that the allowable voltage range shown on the power supply is the same as that indicated on the tester's rear panel. For details, see "1.4 Checking the Line voltage and Fuse".
 - To prevent electric shock, be sure to turn off the POWER switch before connecting/disconnecting the SIGNAL I/O, GPIB, and RS-232C cables.
 - As soon as the power is turned on, all LEDs of the tester light up, and self-diagnosis is started.

To ensure safety, confirm before starting up the tester that all LEDs are lit. It is particularly dangerous to start a test when the DANGER lamp is broken. Even when the DANGER lamp is lit, no output or voltage is being generated.

- ⚠ CAUTION**
- When the POWER switch has been turned off, wait several seconds before turning it on again. Turning the POWER switch on/off repeatedly at insufficient intervals may damage the tester.

-
- NOTE**
- Even after the power is turned on, the tester does not start a test if the settings are invalid or the tester is in the protection status. For details on the invalid settings and protection status, see "3.15 Invalid Settings" and "3.16 Protection".
-

Turning on the power

1. Confirm that the allowable voltage range shown on the power supply is the same as that indicated on the tester's rear panel.
2. Confirm that the AC power cord is properly connected to the AC LINE connector on the rear panel.
3. Plug in the AC power cord.
4. Turn on the tester's POWER switch.

Following the opening screen that displays the ROM version and other information, the LCD displays the last screen displayed when the POWER switch was turned off in the previous test. The first time the POWER switch is turned on following the delivery of the product, the tester is placed in the PROTECTION status by the interlock function.

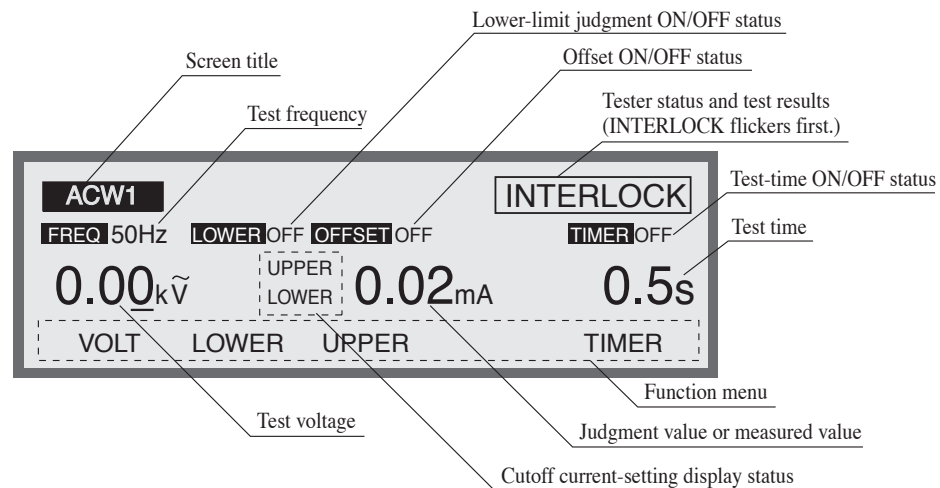

3.2 Pre-Test Zero Adjustment

Before starting a test, perform zero adjustment on the analog voltmeter. Perform the following procedure:

1. Turn off the POWER switch.
2. Confirm that the analog voltmeter indicates "0." Otherwise, adjust the analog-voltage zero adjuster until the voltmeter indicates "0."



3.3 Structure of LCD Screen

The tester's LCD screens are composed of setting screens and execution screens, as shown in Fig. 3-1. On the setting screens, settings can be made for the tester and test conditions or automatic testing can be programmed. The execution screens indicate the test status.

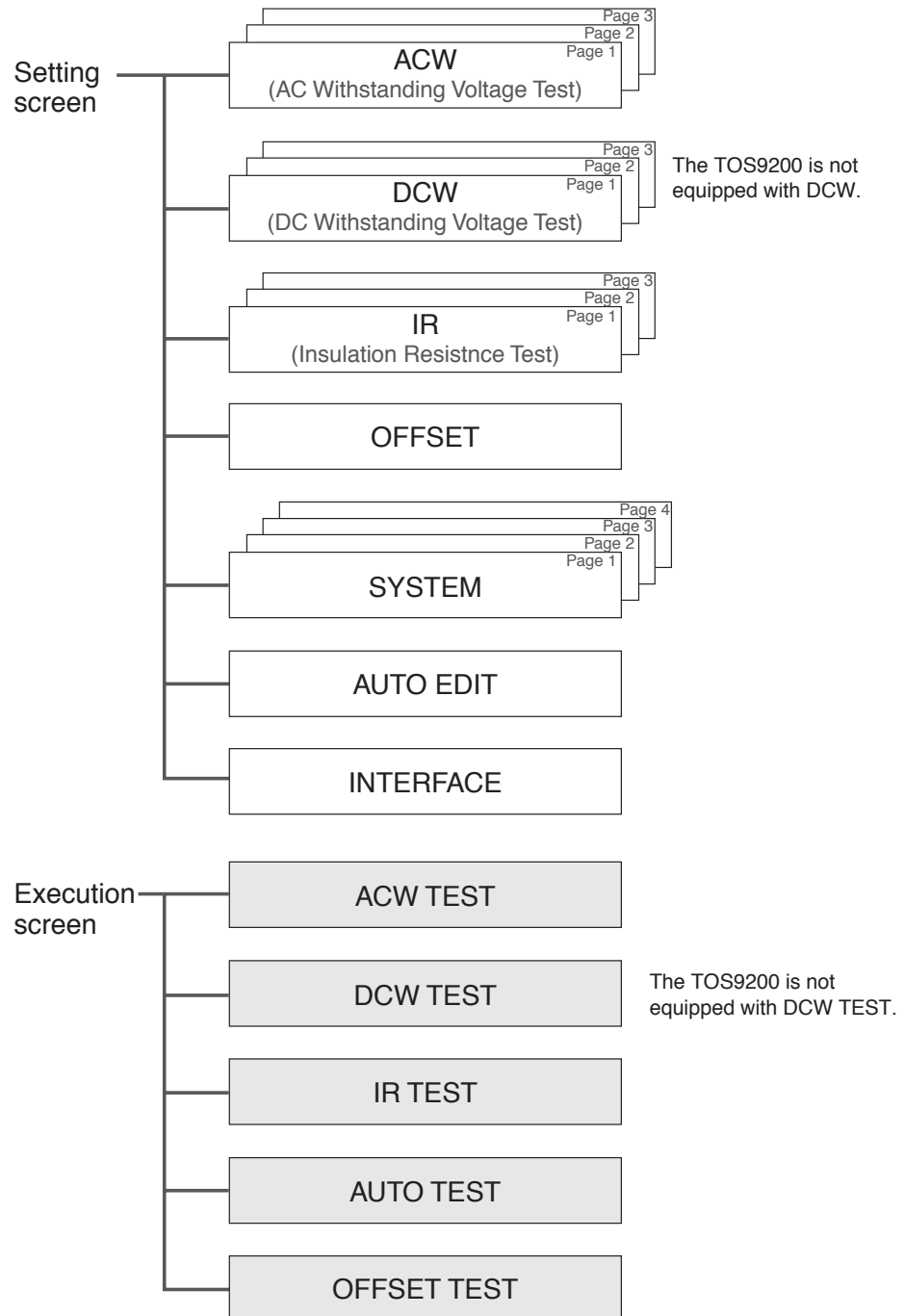

Fig.3-1 Structure of the LCD screen

3.4 Settings for AC Withstanding Voltage Testing

To make settings for an AC withstanding voltage test, use the AC withstanding voltage test screen (ACW). To jump to this screen (ACW1), press the ACW key. The LED on the ACW lights up.

The AC withstanding voltage test screen has three pages from ACW1 to ACW3. To move between these pages, press the SHIFT key + ◀▶ keys. To return to ACW1 from ACW2 or ACW3, press the ACW key.

NOTE

- No setting is permitted in the KEYLOCK status.
-

The three ACW pages allow the following settings to be made:

ACW1

- Test voltage
- Test frequency
- Lower current (LOWER) and ON/OFF of the lower judgement function
- Upper current (UPPER)
- ON/OFF of the offset function
- Test time (TEST TIME) and ON/OFF of the timer function

ACW2

- Start voltage
- Voltage rise time (RISE TIME)
- Voltage fall time (FALL TIME)
- Output-voltage range
- SLOW/MID/FAST settings for the current detection response (RESPONSE)
- LOW/GUARD settings for the GND

ACW3

- Channel settings for the high-voltage scanner
- ON/OFF of the contact check function

To move the cursor between items, use the ▲▼◀▶ keys.

When a function is shown on keys F1 to F5, they can be used to jump to the target item. To make settings for the items to be displayed on these keys, press the SHIFT key + F1 to F5 keys.

3.4.1 Settings on the ACW1 Screen

Settings for AC withstanding voltage testing

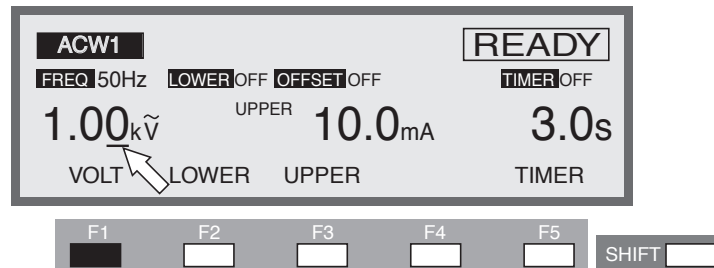

The test voltage to be applied to a DUT can be set between AC 0.00 kV and 5.20 kV (at a resolution of 0.01 kV).

To make a setting, use the rotary knob with the cursor at the test voltage.

1. If the cursor is not at the test voltage, press the F1 (VOLT) key to bring the cursor to the test voltage (the ▲ ▼ ◀ ▶ keys can also be used).
2. Move the cursor to the target digit using the ◀ ▶ keys.
3. Set a test voltage using the rotary knob.

NOTE

- When settings are being made, if the test voltage multiplied by the upper current exceeds 550 VA, “READY” disappears and “OVER 550VA” flickers at the top right of the LCD to indicate that testing cannot be performed.

In such a case, reduce the test voltage or the upper current.

- If the output voltage range is at AUTO and the test voltage is 2.6 kV or less, the 2.5 kV range is selected automatically. It is therefore impossible to change the voltage to more than 2.6 kV during the test.

Setting the frequency

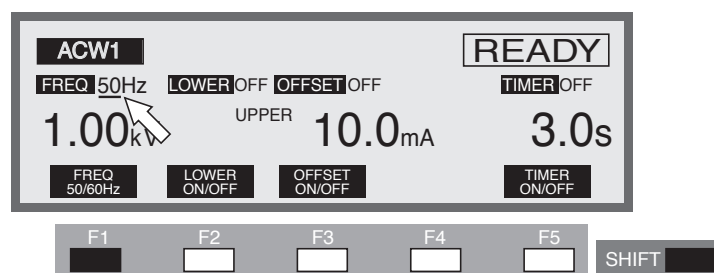

The frequency of the test voltage can be set to either 50 Hz or 60 Hz. The test frequency can be set using the SHIFT + F1 keys (press the F1 key while pressing the SHIFT key), regardless of where the cursor is positioned. Every time the SHIFT + F1 keys are pressed, the setting alternates between 50 Hz and 60 Hz.

The ▲ ▼ ◀ ▶ keys can also be used to move the cursor to the test frequency. When the cursor is at the test frequency, the rotary knob can be used to make settings.

Turn the rotary knob clockwise: 60 Hz

Turn the rotary knob counterclockwise: 50 Hz

Turning the lower judgement function ON/OFF

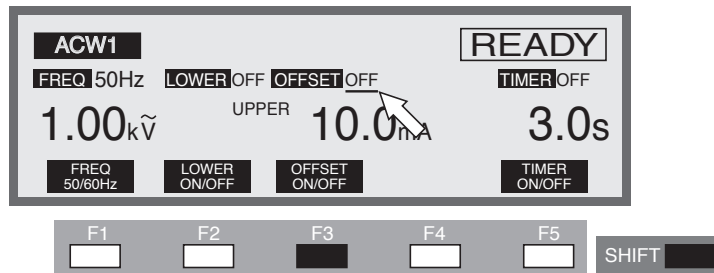

The lower judgement function can be turned on/off.

When the lower judgement function is on, the test result is judged to be FAIL if the measured current drops below the lower current, and the test is ended.

The lower current is explained in the following section. The lower judgement function can be set to ON/OFF using the SHIFT + F2 keys, regardless of where the cursor is positioned.

Every time the SHIFT + F2 keys are pressed, the setting alternates between ON and OFF. The ▲ ▼ ◀ ▶ keys can also be used to move the cursor to ON/OFF of the lower judgement function. If the cursor is at the ON/OFF of the lower judgement function, the rotary knob can be used to make settings.

Turn the rotary knob clockwise: ON

Turn the rotary knob counterclockwise: OFF

NOTE

- In AC withstanding voltage testing, the maximum rated current of 100 mA is not attained at a test voltage of 200 V or less. If outputs are short-circuited during the test at a test voltage of 200 V or less and an upper judgement of 100 mA or more is made, the test result may not be judged as FAIL, thus activating the output-voltage monitor function.
-

Setting the lower current (LOWER)

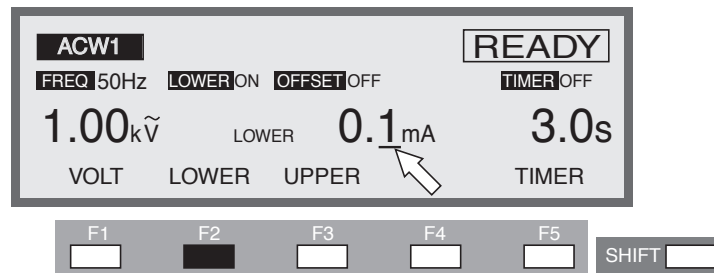

The lower current can be set between 0.01 mA and 110 mA (at a resolution of 0.01 mA for 0.01 mA to 9.99 mA, 0.1 mA for 10.0 mA to 99.9 mA, and 1 mA for 100 mA to 110 mA).

When the cursor is at the lower current, the rotary knob can be used to make settings. When the lower judgement function is set to ON and the measured current is at or below the lower current, the test ends with a FAIL judgement.

When the fluctuations of the leakage current of the DUT are limited and exceed the current by a sufficient amount to permit the tester to make a judgement, set the lower current below the smallest fluctuation. By making such a setting, it is possible to identify a DUT that generates a small leakage current and even detect disconnection and failed contact in the test leadwire, ensuring an accurate withstanding voltage test. If the lower judgement function is not to be used, turn it off.

1. To display the lower current, press the F2 key (LOWER). While the lower current is displayed, the cursor can be moved using the ▲ ▼ ◀ ▶ keys.
2. Using the ◀ ▶ keys, move the cursor to the target digit.
3. Using the rotary knob, set the lower current.

NOTE

- If the lower current is set at or above the upper current while the lower judgement function is on, "READY" disappears and "UP<=LOW" flickers at the top right of the LCD to indicate that testing cannot be performed (the lower current is factory-set to 0.10 mA).

Lower the lower current or raise the upper current.

The invalid settings shown above have the priority specified in "3.15 Invalid Settings". When there are two or more invalid settings, messages with higher priority may be displayed first.

- As described in "Chapter 8 Specifications", in a high-sensitivity and high-voltage test using an alternating current, a current larger than the lower current may flow into the stray capacity of the test leadwire and other components, making it impossible to conduct lower judgement. No current flows into a DUT if it is not connected to the tester. Thus, the current flowing into the DUT is smaller than the lower current. The test may then be judged as FAIL. Nonetheless, if a current larger than the lower current flows into the stray capacity, the current detection circuit detects the current and makes a PASS judgement. Carefully check combined judgement errors. In addition, disconnect the DUT under preset test conditions and confirm that a FAIL judgement is possible.
- No lower judgement is made while the voltage is rising or falling.

Setting the upper current (UPPER)

-
- CAUTION** • If the upper current is set above 50 mA, the protective circuit may be activated. To avoid this, set the output time to 30 minutes or less and provide a pause longer than the output time.
-

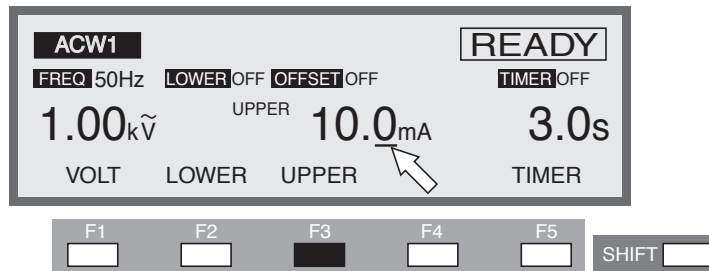

The upper current can be set between 0.01 mA and 110 mA (at a resolution of 0.01 mA for the 0.01 mA to 9.99 mA range, 0.1 mA for the 10.0 mA to 99.9 mA range, and 1 mA for the 100 mA to 110 mA range).

When a current exceeding the upper current is detected, the test ends with a FAIL judgement.

When the cursor is at the upper current, the rotary knob can be used to make settings.

1. To display the upper current, press the F3 key (UPPER). (When the upper current is displayed, the cursor can be moved using the ▲▼◀▶ keys.)
2. Using the ◀▶ keys, move the cursor to the target digit.
3. Using the rotary knob, set the upper current.

-
- NOTE** • If the upper current is set at or below the lower current while the lower judgement function is on, “READY” disappears and “UP<=LOW” flashes at the top right of the LCD to indicate that testing cannot be performed. (The upper current is factory-set to 0.20 mA.)

Lower the lower current, raise the upper current, or turn off the lower judgement function.

- When settings are being made, if the test voltage multiplied by the upper current exceeds 550 VA, “READY” disappears and “OVER 550 VA” flashes at the top right of the LCD to indicate that testing cannot be performed.

In such a case, reduce the test voltage or the upper current.

Turning the offset cancel function ON/OFF

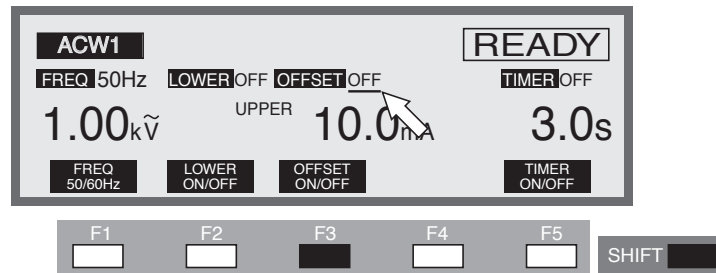

The offset cancel function can be turned on/off. When it is on, this function displays the difference calculated by subtracting from the measured value the offset value recorded by the function ("3.9 Offset Cancel Function").

NOTE

- To use the recorded offset value, make the same settings for the frequency, LOW/GUARD of the GND, and the scanner as were made for the offset value. Each time the test voltage is changed, the recorded offset value is converted to reflect the change. For details, see "3.9 Offset Cancel Function".

The offset cancel function can be set to ON/OFF using the SHIFT + F3 keys, regardless of the location of the cursor. Each time the SHIFT + F3 keys are pressed, ON and OFF alternate.

The ▲ ▼ ◀ ▶ keys can also be used to move the cursor to ON/OFF of the offset cancel function. If the cursor is at ON/OFF of the offset cancel function, the rotary knob can be used to make settings.

Turn the rotary knob clockwise : ON

Turn the rotary knob counterclockwise : OFF

Turning the timer ON/OFF

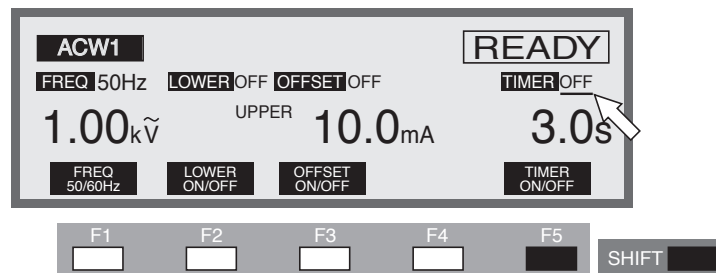

Make ON/OFF settings for the timer function.

When the timer function is turned on, the test time can be controlled as shown in "Setting the test time" in the next section. When the preset test time has elapsed with a recorded leakage current between the lower and upper currents, the test ends

with a PASS judgement. The timer function can be set to ON/OFF using the SHIFT + F5 keys, regardless of the location of the cursor. Each time the SHIFT + F5 keys are pressed, ON and OFF alternate.

The ▲ ▼ ◀ ▶ keys can also be used to move the cursor to ON/OFF of the timer function. When the cursor is at ON/OFF of the timer function, the rotary knob can be used to make settings.

Turn the rotary knob clockwise : ON

Turn the rotary knob counterclockwise : OFF

Setting the test time (TEST TIME)

-
- CAUTION** • If the upper current is set above 50 mA, the protective circuit may be activated. To avoid this, set the output time to 30 minutes or less and provide a pause longer than the output time.
-

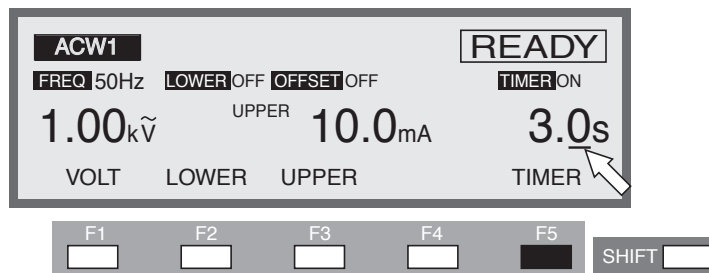

The time for which a preset voltage is applied to the DUT can be set to 0.3 s through 999 s (at a resolution of 0.1 s for the 0.3 s to 99.9 s range and 1 s for the 100 s to 999 s range).

When the cursor is at the test time, the rotary knob can be used to make settings.

1. To move the cursor to the timer, press the F5 key (TIMER). (The ▲ ▼ ◀ ▶ keys can also be used.)
2. Using the ◀ ▶ keys, move the cursor to the target digit.
3. Using the rotary knob, set the test time.

3.4.2 Settings on the ACW2 screen

Setting the start voltage

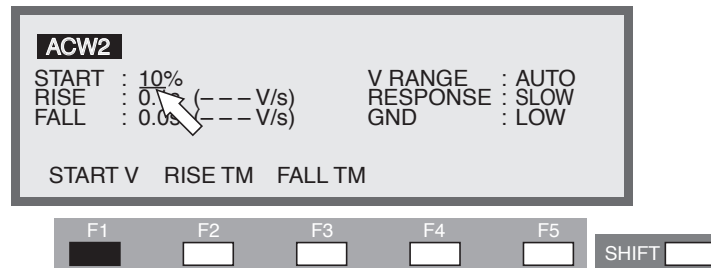

For an AC withstanding voltage test, set the start voltage as a percentage of the test voltage, to 0% through 99% (at a resolution of 1%). When the cursor is located to the right of START, settings can be made using the rotary knob.

1. To move the cursor to the right of START, press the F1 key (START V). (The ▲ ▼ ◀ ▶ keys can also be used.)
2. Using the rotary knob, set the start voltage.

NOTE

- When the start voltage is set to 1% or more, approximately 100 ms is required for the tester to reach the start voltage from 0 V.

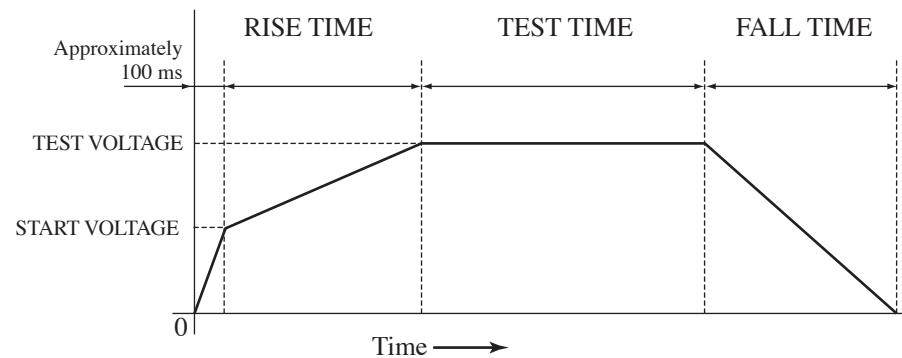
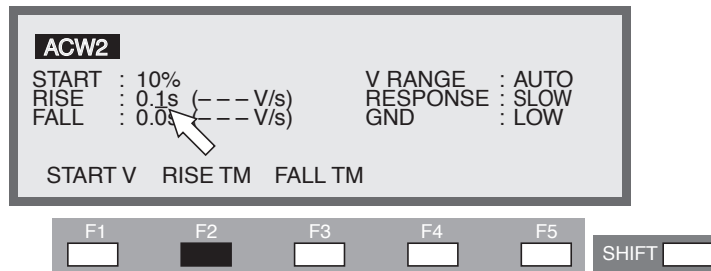

Fig.3-2 Start voltage (ACW)

Setting the voltage rise time (RISE TIME)



The rise time between the start voltage and the test voltage can be set to 0.1 s through 200 s (at a resolution of 0.1 s for the 0.1 s to 99.9s range and 1 s for the 100 s to 200s range).

When the cursor is to the right of RISE, settings can be made using the rotary knob.

1. To move the cursor to the right of RISE, press the F2 key (RISE TM). (The ▲ ▼ ◀ ▶ keys can also be used.)
2. Using the ◀ ▶ keys, move the cursor to the target digit.
3. Using the rotary knob, set the rise time.

The figure (V/s) in parentheses represents the voltage increase per second calculated for reference using the preset value.

If the value cannot be displayed in three digits, “---” is displayed instead.

Setting the voltage fall time (FALL TIME)

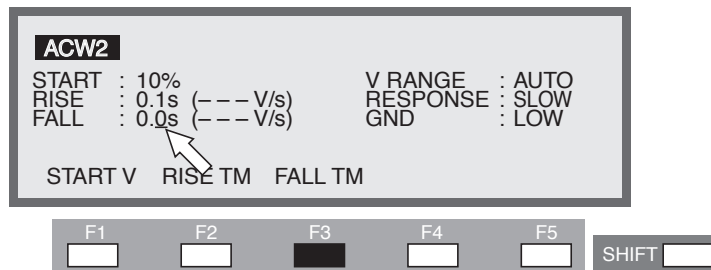

When the test ends with a PASS judgement, the voltage falls to 0 V during the preset voltage fall time. This voltage fall time can be set to 0.0 s through 200 s (at a resolution of 0.1 s for the 0.1 s to 99.9s range and 1 s for the 100 s to 200s range).

When the cursor is to the right of FALL, settings can be made using the rotary knob.

1. To move the cursor to the right of FALL, press the F3 key (FALL TM). (The ▲ ▼ ◀ ▶ keys can also be used.)
2. Using the ◀ ▶ keys, move the cursor to the target digit.
3. Using the rotary knob, set the fall time.

The figure (V/s) in parentheses represents the voltage fall per second calculated for reference using the set value.

If the value cannot be displayed in three digits, “---” is displayed instead.

Setting the output-voltage ranges (V RANGE)

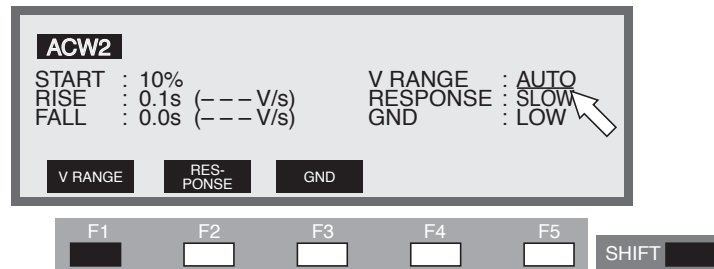

Switch the output-voltage ranges.

For the output-voltage range, select between AUTO and 5 kV.

The 5-kV range can be changed at any time up to 5.20 kV.

The AUTO range automatically selects either the 2.5 kV range or the 5 kV range, as it is selected in the pre-test settings. If the pre-test setting exceeds 2.6 kV, the 5 kV range is selected. Otherwise, the 2.5 kV range is selected. Once the 2.5 kV range has been selected, the voltage cannot be reset above 2.6 kV during the test.

To run a test at or below 2.6 kV, it is recommended that the AUTO range be selected to prevent the application of an unnecessarily large voltage.

The output-voltage ranges can be switched using the SHIFT + F1 keys (V RANGE), regardless of the location of the cursor. Each time the SHIFT + F1 keys are pressed, AUTO and 5 kV alternate.

Using the ▲ ▼ ◀ ▶ keys, move the cursor to the right of the output-voltage range (V RANGE), and make settings using the rotary knob.

Turn the rotary knob clockwise : 5 kV

Turn the rotary knob counterclockwise : AUTO

Setting the current detection response (RESPONSE)

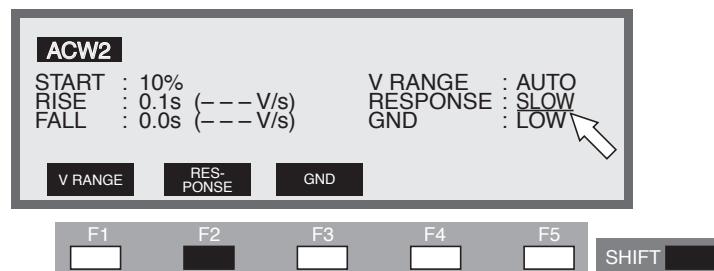

By changing the integrated time constant of the current detection circuit, switch the current detection response for UPPER FAIL judgement.

Integrated time constant

- SLOW : Approximately 40 ms
- MID : Approximately 4 ms
- FAST : Approximately 0.4 ms

The current detection response can be set using the SHIFT + F2 keys (RESPONSE), regardless of the location of the cursor. Each time the SHIFT + F2 keys are pressed, the selection is switched among SLOW, MID, and FAST, in order.

Using the ▲ ▼ ◀ ▶ keys, move the cursor to the right of the current detection response (RESPONSE), and make settings using the rotary knob.

Turn the rotary knob clockwise : SLOW → MID → FAST

Turn the rotary knob counterclockwise : FAST → MID → SLOW

■ SLOW

In the SLOW mode, a current is detected at an integrated time constant of approximately 40 ms in response to the mean value. This is equivalent to the current-detection response of Kikusui's general-purpose AC withstanding voltage tester. This setting complies with the dielectric breakdown detection defined in the safety standards, and can be used to conduct withstanding voltage testing of ordinary electric devices and electronic components.

NOTE

- According to the safety standard (IEC60950 1999), “dielectric breakdown is regarded to have occurred when, as a result of the application of a test voltage, the flowing current sharply increases beyond control, that is, it becomes impossible to maintain the flowing current below a certain level. Coronal discharge or instantaneous flashover is not regarded as dielectric breakdown.” In accordance with this standard, Kikusui's general-purpose AC withstanding voltage tester makes a FAIL judgement for a test if the tester, having a mean-value-responsive current-detection circuit, detects a current above the upper current (UPPER) flowing into a DUT.

■ MID, FAST

MID and FAST, with integrated time constants of approximately 4 ms and 0.4 ms, respectively, detect currents in response to the mean value, similarly to peak detection. These two modes respond more quickly than the SLOW mode, making them suitable for the detection of an instantaneous discharge, as well as a discharge containing high-frequency elements. Due to their excellent ability to detect the upper current, they are effective in withstanding voltage tests on DUTs that are prone to dielectric breakdown, such as small electronic devices. However, the two modes are not always useful in repeatable withstanding voltage tests, as they detect even a minimal discharge.

⚠ CAUTION

- Even in the FAST mode, minimal discharges are sometimes not detected. This tester is designed for conducting withstanding voltage tests on electric devices and electronic components under a safety standard. It has a transformer capacity of 500 VA with a short-circuit current of 200 mA. Therefore, the tester may destroy some types of electronic components such as small relays and semiconductors, even if the tester is capable of detecting dielectric breakdowns by monitoring an overcurrent.
-

Setting LOW/GUARD for the GND

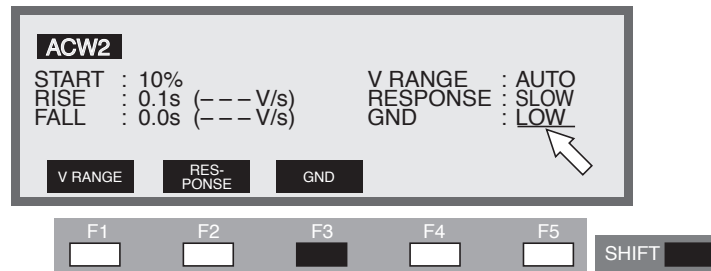

You can select either of the following two measurement modes;

- the LOW mode that the GND is connected to the tester's LOW terminal,
- the GUARD mode that the GND is used as guard.

In both modes, the tester detects the current flowing into the LOW terminal from the HIGH VOLTAGE terminal via the DUT. In the LOW mode, the LOW terminal is connected to the chassis. This leads to the problem that the stray capacity and insulation resistance existing between the test leadwire or jigs and the earth are included in the measurement. Nonetheless, the GND mode ensures safe testing, as it does not short-circuit the ammeter.

In the GUARD mode, on the other hand, only the current flowing into the LOW terminal from the HIGH VOLTAGE terminal via the DUT is measured, and the influence of the stray capacity and insulation resistance existing between the test leadwire or jigs and the earth is eliminated. For this reason, the GUARD mode is effective in measurements that require high sensitivity and high accuracy. At the same time, however, the ammeter can be short-circuited, posing a grave danger if the LOW terminal and the chassis are short-circuited when part of the DUT is connected to an earth ground. If it is possible that the DUTs and jigs are grounded, select the LOW mode.

To switch between the two modes, use the SHIFT + F3 keys, regardless of the location of the cursor. Each time the SHIFT + F3 keys are pressed, LOW and GUARD alternate.

Using the ▲▼◀▶ keys, move the cursor to the right of GND; settings can then be made using the rotary knob.

Turn the rotary knob clockwise : GUARD

Turn the rotary knob counterclockwise : LOW

When LOW is selected, the LED to the left of the LOW terminal lights up.

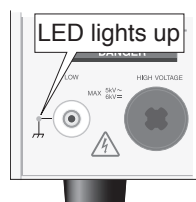

■ LOW

In the LOW mode, the current which flows through the LOW terminal by stray capacity and insulation resistance of the test leadwire and jigs is included in measurements, as shown in Fig. 3-3 (A) and (B). However, the ammeter is protected from short-circuiting, thereby ensuring safe testing regardless of whether the DUT is grounded. For this reason, it is recommended that LOW be set in ordinary tests.

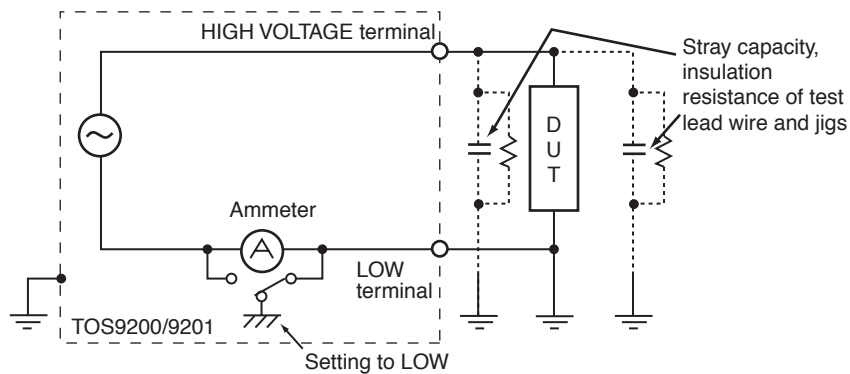

(A) DUT grounded

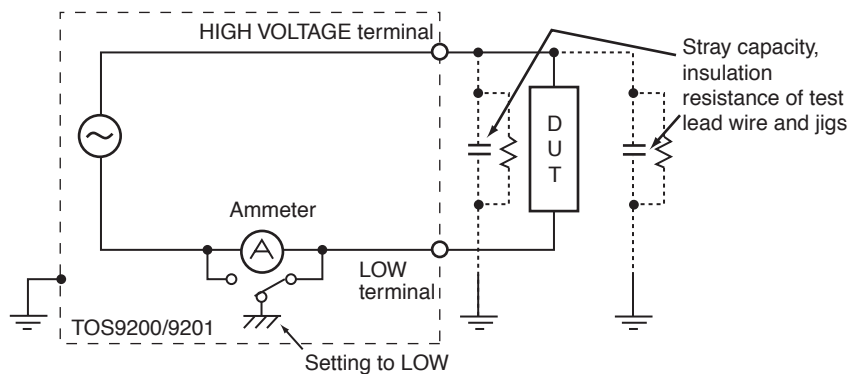

(B) DUT not grounded

Fig.3-3 Selecting LOW

■ GUARD

- ⚠ WARNING**
- If it is not known whether the DUT or jig is grounded, never select GUARD. If GUARD is selected while the DUT is grounded, the ammeter will be short-circuited, thereby disabling measurement and posing a grave danger. See Fig. 3-4 (B).
 - If GUARD is selected, do not connect this tester to any measuring instruments or other devices that involve single-side grounding, such as Kikusui's high-voltage digital voltmeter 149-10A or current calibrator TOS1200. Otherwise, the ammeter will be short-circuited. See Fig. 3-4 (A).

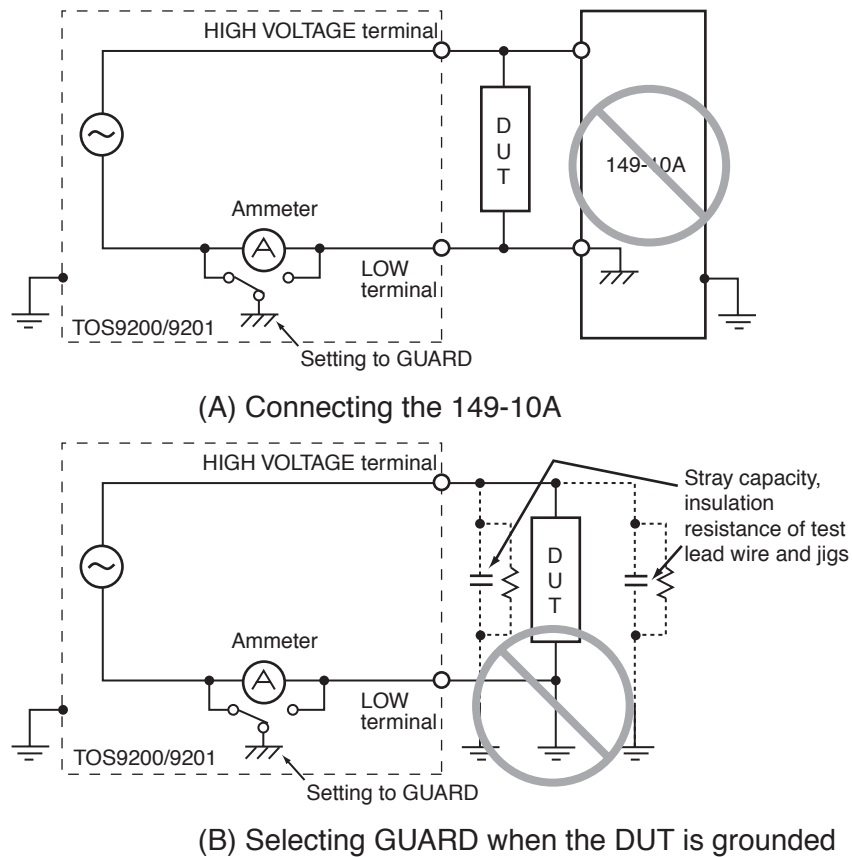

Fig.3-4 Dangerous connection

- CAUTION** • If the LOW terminal of this tester is connected to the HIGH or LOW terminal of the earth continuity tester TOS6200, the ammeter will be subject to measurement errors if GUARD is selected, as the resistor inside the TOS6200 is connected in parallel to the tester's ammeter. Therefore, to use the TOS6200, avoid connecting these terminals or select LOW.

Select GUARD only when DUTs such as small electronic components and jigs are completely “floating” electrically.

The GUARD mode enables high-sensitivity, high accuracy measurements to be made, as it excludes the current by stray capacity and insulation resistance of the test leadwire and jigs.

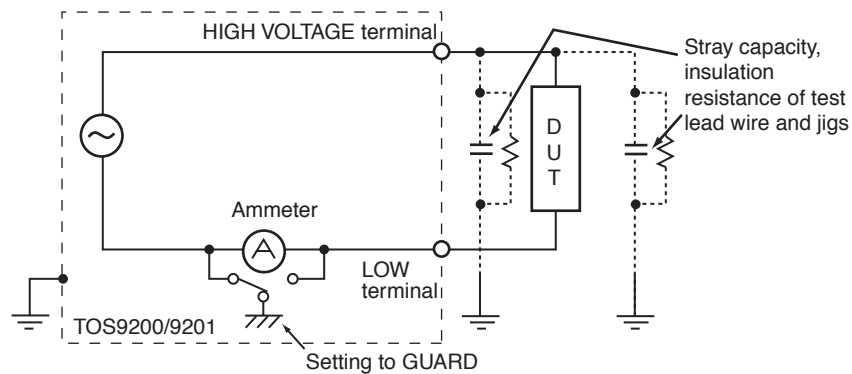
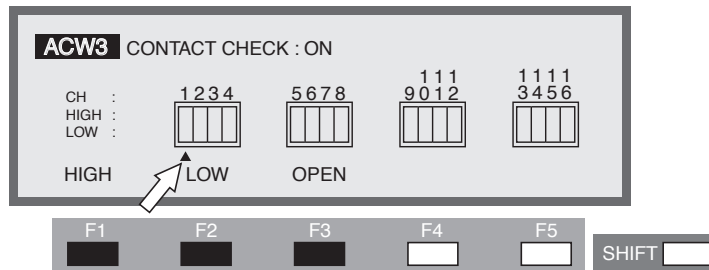

Fig.3-5 Selecting GUARD

3.4.3 Settings on the ACW3 screen

Channel settings for the high-voltage scanner



Make settings with the optional scanner connected.

Each channel can be set to HIGH, LOW, or OPEN.

Use the ◀ ▶ keys to move the cursor (▲) to a channel, and then use the F1, F2, and F3 keys to make settings.

If the channel has already been specified, settings can be made using the rotary knob.

All channels can be opened using the SHIFT + F1 keys, regardless of the location of the cursor.

NOTE

- If an unconnected channel is selected, “INVALID CH” flashes on the LCD.

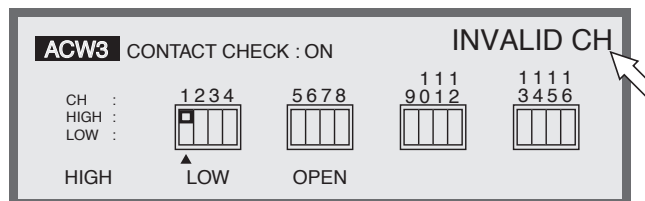

WARNING

- If the test leadwire is not connected to the DUT, do not leave the test leadwire connected to the scanner’s output terminal.

The TOS9220 scanner does not have a contact check function to check connections to the DUT. If the tester is set to the high-voltage (HIGH) level, a test can be started using a channel with the test leadwire not connected to the DUT.

NOTE

- To clearly indicate the relationships between the connected test leadwire and the channel, affix the Channel Display Seal (provided for the scanner) to the test leadwire.

Turning the contact check ON/OFF

When the optional high-voltage scanner TOS9221 (with a contact check function) is connected to the tester, the continuity between the test leadwire and the DUT can be checked using the HIGH or LOW terminal prior to the application of a test voltage. To do so, turn on the contact check function.

With the high-voltage scanner TOS9220, a check of the continuity is conducted up to the inside of the scanner only.

To turn the contact check function on/off, use the SHIFT + F5 keys.

Each time the SHIFT + F5 keys are pressed, ON and OFF alternate, regardless of the location of the cursor. The cursor moves to CONTACT CHECK.

Using the ▲ key, move the cursor to the right of CONTACT CHECK. Settings can also be made using the rotary knob.

Turn the rotary knob clockwise : ON

Turn the rotary knob counterclockwise : OFF

Press the ACW key to return to the ACW1 screen, and then press the START switch. READY will then disappear from the LCD, and a contact check will start for each channel.

The test starts as soon as the continuity is confirmed, and continues until the test time preset on the timer has elapsed or the STOP switch is pressed.

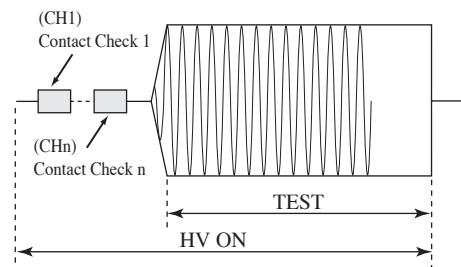
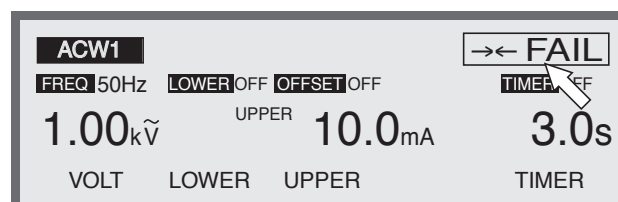

Fig.3-6 Contact check

The contact check time is calculated using the following formula:

Contact check time = 260 ms + 60 ms x (number of channels set to HIGH or LOW)

When a continuity error is detected in a contact check, “ →← FAIL” appears at the top right of the LCD. On the high-voltage scanner, the LED of the failed channel lights up in orange.



3.5 Settings for DC Withstanding Voltage Testing (TOS9201 only)

To make settings for a DC withstanding voltage test, use the DC Withstanding Voltage-Test Setting screen (DCW).

To jump to this screen (DCW1), press the DCW key. The LED on the DCW key lights up.

The DC Withstanding Voltage-Test Setting screen has three pages, from DCW1 to DCW3. To move between these pages, press the SHIFT key + ◀ ▶ keys. To return to DCW1 from DCW2 or DCW3, press the DCW key.

NOTE

- No setting can be made in the KEYLOCK status.
-

The three DCW pages allow the following settings to be made:

DCW1

- Test voltage
- Lower current (LOWER) and ON/OFF of the lower judgement function
- Upper current (UPPER)
- Test time (TEST TIME) and ON/OFF of the timer function

DCW2

- Start voltage
- Voltage rise time (RISE TIME)
- Judgement wait time (WAIT TIME)
- LOW/GUARD settings for the GND

DCW3

- Channel settings for the high-voltage scanner
- ON/OFF of the contact check function

To move the cursor between items, use the ▲ ▼ ◀ ▶ keys.

When a function is shown on the F1 to F5 keys, they can be used to jump to the target item. To make settings for items displayed on these keys, press the SHIFT key + F1 to F5 keys.

3.5.1 Settings on the DCW1 screen

Setting the test voltage for DC withstanding voltage testing

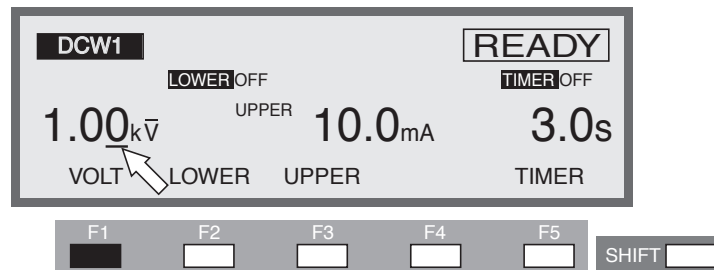

The test voltage to be applied to a DUT can be set to DC 0.00 kV through 6.10 kV (at a resolution of 0.01 kV).

To make settings, use the rotary knob with the cursor at the test voltage.

1. To bring the cursor to the test voltage, press the F1 (VOLT) key (the ▲ ▼ ◀ ▶ keys can also be used).
2. Using the ◀ ▶ keys, move the cursor to the target digit.
3. Using the rotary knob, set a test voltage.

NOTE

- When settings are being made, if the test voltage multiplied by the upper current exceeds 55 W, “READY” disappears and “OVER 55 W” flashes at the top right of the LCD to indicate that testing cannot be performed. In such a case, reduce the test voltage or the upper current.

Turning the lower judgement function ON/OFF

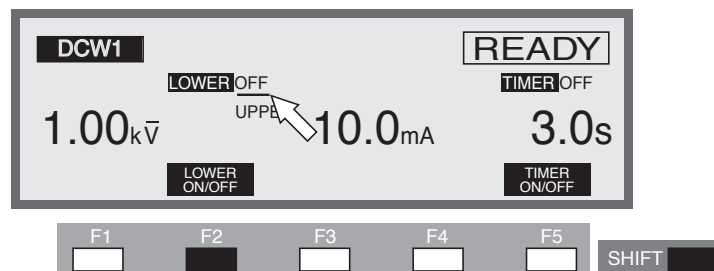

The lower judgement function can be turned on/off.

When the lower judgement function is on, the test ends with a FAIL judgement if the measured current drops below the lower current. The lower current is explained in the following section.

The lower judgement function can be set to ON/OFF using the SHIFT + F2 keys, regardless of the location of the cursor. Each time the SHIFT + F2 keys are pressed, ON and OFF alternate.

The ▲ ▼ ◀ ▶ keys can also be used to move the cursor to ON/OFF of the lower judgement function. If the cursor is at ON/OFF of the lower judgement function, the rotary knob can be used to make settings.

Turn the rotary knob clockwise: ON

Turn the rotary knob counterclockwise: OFF

Setting the lower current (LOWER)

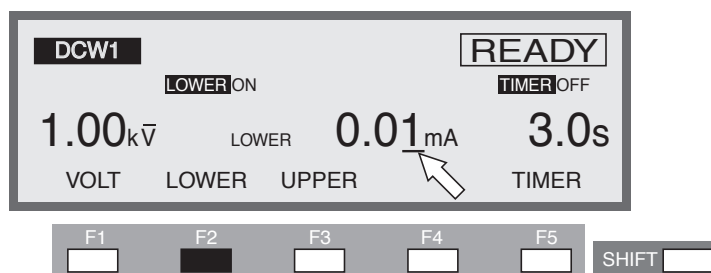

The lower current can be set between 0.01 mA and 11.0 mA (at a resolution of 0.01 mA for the 0.01 mA to 9.99 mA range, and 0.1 mA for the 10.0 mA to 11.0 mA range).

When the lower judgement function is set to ON and the measured current is at or below the lower current, the test ends with a FAIL judgement.

If the fluctuation of the leakage current of the DUT is limited and the leakage current is sufficiently high to enable the tester to make a judgement, set the lower current below the smallest fluctuation. Making this setting makes it possible to identify a DUT that contains an exceptionally small leakage current, and even to detect a disconnection and failed contact in the test leadwire, thus ensuring a high-quality withstanding voltage test. If the lower judgement function is not to be used, turn it off.

If the cursor is at the lower current, the rotary knob can be used to make settings.

1. If the lower current is not displayed, press the F2 key (LOWER) to display it. (When the lower current is displayed, the cursor can be moved using the ▲ ▼ ◀ ▶ keys.)
2. Using the ◀ ▶ keys, move the cursor to the target digit.
3. Using the rotary knob, set the lower current.

NOTE

- If the lower current is set at or above the upper current while the lower judgement function is on, "READY" disappears and "UP<=LOW" flashes at the top right of the LCD to indicate that testing cannot be performed (the lower current is factory-set to 0.10 mA).

Lower the lower current or raise the upper current.

- No lower judgement is made while the voltage is rising or before the WAIT TIME has elapsed.

Setting the upper current (UPPER)

- CAUTION** • If the upper current is set to above 5 mA, the protective circuit may be activated. To avoid this, set the output time to 1 minute or less and provide a pause longer than the test time.

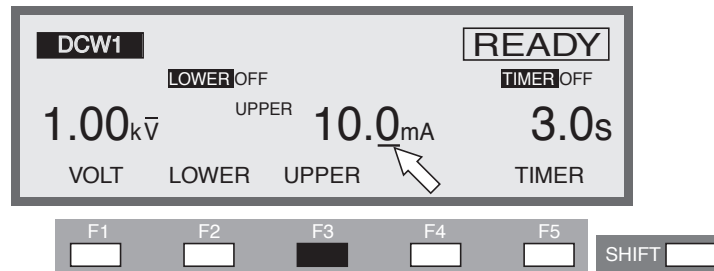

The upper current can be set to 0.01 mA through 11.0 mA (at a resolution of 0.01 mA for the 0.01 mA to 9.99 mA range, and 0.1 mA for the 10.0 mA to 11.0 mA range).

Once a current exceeding the upper current is detected, the test ends with a FAIL judgement.

If the cursor is at the upper current, the rotary knob can be used to make settings.

1. If the upper current is not displayed, press the F3 key (UPPER) to display it (while the upper current is displayed, the cursor can be moved using the ▲▼◀▶ keys).
2. Using the ◀▶ keys, move the cursor to the target digit.
3. Using the rotary knob, set the upper current.

- NOTE** • With the lower judgement function on, if the upper current is set at or below the lower current, “READY” disappears and “UP<=LOW” flashes at the top right of the LCD to indicate that testing cannot be performed (the lower current is factory-set to 0.20 mA).

Lower the lower current, raise the upper current, or turn off the lower judgement function.

- When settings are being made, if the test voltage multiplied by the upper current exceeds 55 W, “READY” disappears and “OVER 55 W” flashes at the top right of the LCD to indicate that testing cannot be performed. In such a case, lower the test voltage or the upper current.

Turning the timer ON/OFF

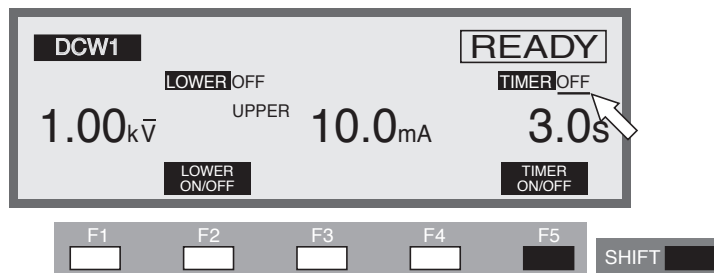

Make ON/OFF settings for the timer function.

When the timer function is turned on, the test time can be controlled, as shown in “Setting the test time” in the next section. When the preset test time has elapsed with a leakage current recorded between the lower and upper currents, the test ends with a PASS judgement.

The timer function can be set to ON/OFF using the SHIFT + F5 keys, regardless of the location of the cursor. Each time the SHIFT + F5 keys are pressed, ON and OFF alternate.

The ▲ ▼ ◀ ▶ keys can also be used to move the cursor to ON/OFF of the timer function. If the cursor is at ON/OFF of the timer function, the rotary knob can be used to make settings.

Turn the rotary knob clockwise : ON

Turn the rotary knob counterclockwise : OFF

Setting the test time (TEST TIME)

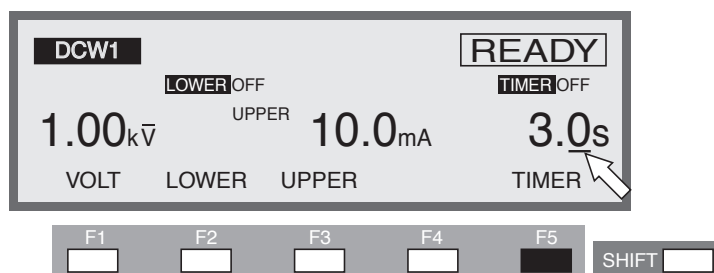

The time during which a preset voltage is applied to the DUT can be set to 0.3 s through 999 s (at a resolution of 0.1 s for the 0.3 s to 99.9s range and 1 s for the 100 s to 999s range).

When the cursor is at the timer, the rotary knob can be used to make settings.

1. To move the cursor to the timer, press the F5 key (TIMER). (The ▲ ▼ ◀ ▶ keys can also be used.)
2. Using the ◀ ▶ keys, move the cursor to the target digit.
3. Using the rotary knob, set the test time.

3.5.2 Settings on the DCW2 screen

Setting the start voltage

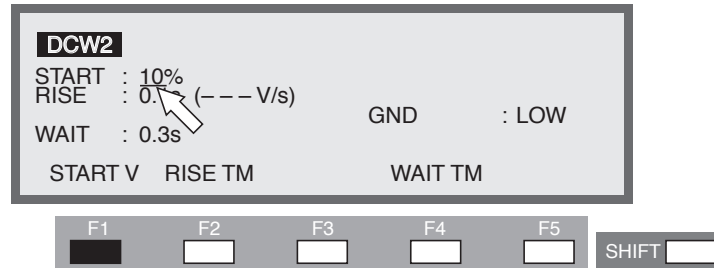

For a DC withstanding voltage test, set the start voltage as a percentage of the test voltage, to 0% through 99% (at a resolution of 1%). When the cursor is located to the right of START, settings can be made using the rotary knob.

1. To move the cursor to the right of START, press the F1 (START V) key (the \blacktriangle \blacktriangledown \blacktriangleleft \blacktriangleright keys can also be used).
2. Using the rotary knob, set the start voltage.

NOTE

- When the start voltage is set to 1% or more, approximately 100 ms is required for the tester to reach the start voltage from 0 V.

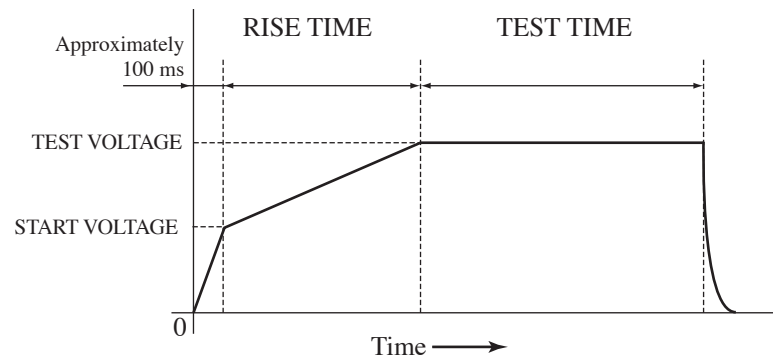
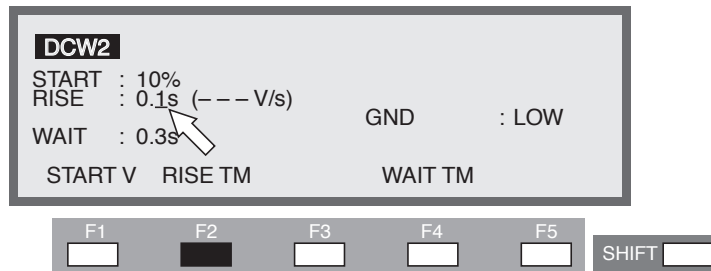

Fig.3-7 Start voltage (DCW)

Setting the voltage rise time (RISE TIME)



The rise time between the start voltage and the test voltage can be set to 0.1 s through 200 s (at a resolution of 0.1 s for the 0.1 s to 99.9s range and 1 s for the 100 s to 200s range).

When the cursor is to the right of RISE, settings can be made using the rotary knob.

1. To move the cursor to the right of RISE, press the F2 key (RISE TM). (The ▲ ▼ ◀ ▶ keys can also be used.)
2. Using the ◀ ▶ keys, move the cursor to the target digit.
3. Using the rotary knob, set the rise time.

The figure (V/s) in parentheses represents the voltage increase per second calculated for reference using the set value. If the value cannot be displayed in three digits, "--" is displayed instead.

Setting the WAIT TIME

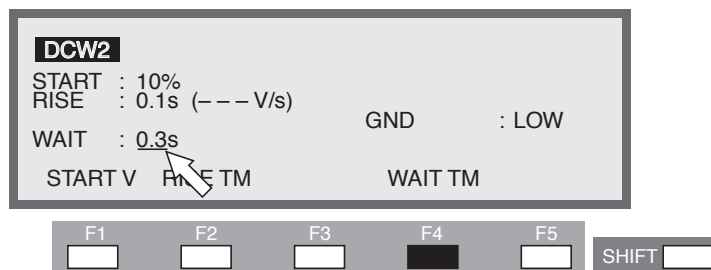

In DC withstanding voltage testing, if a test voltage is applied to a DUT that contains capacitive elements, a large charge current may flow until charging is completed. To avoid upper fail judgement by the charge current, a wait time must be provided from the starts of START VOLTAGE, and upper fail judgement will be ignored during wait time.

Set the wait time to 0.3 s through 10.0 s (at a resolution of 0.1 s).

When the cursor is located to the right of WAIT, the rotary knob can be used to make settings.

1. To move the cursor to the right of WAIT, press the F4 key (WAIT TM). (The ▲ ▼ ◀ ▶ keys also can be used.)
2. Using the rotary knob, set the wait time.

NOTE

- With the timer ON, if the wait time thus set exceeds the sum of the voltage rise time and the test time, “OVER WAIT” flashes on the LCD to indicate that testing cannot be performed.

Setting LOW/GUARD for the GND

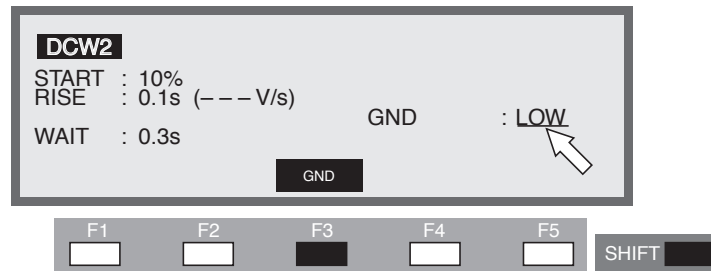

You can select either of the following two measurement modes;

- the LOW mode that the GND is connected to the tester’s LOW terminal,
- the GUARD mode that the GND is used as guard.

In both modes, the tester detects the current flowing into the LOW terminal from the HIGH VOLTAGE terminal via the DUT. In the LOW mode, the LOW terminal is connected to the chassis. This leads to the problem of the insulation resistance between the test leadwire and jigs and the earth being included in the measurement. Nonetheless, the GND mode ensures safe testing, as it does not short-circuit the ammeter.

In the GUARD mode, on the other hand, only the current flowing into the LOW terminal from the HIGH VOLTAGE terminal via the DUT is measured, while the influence of the insulation resistance between the earth and the test leadwire and jigs is eliminated. For this reason, the GUARD mode is effective in measurements that require high sensitivity and high accuracy. At the same time, however, the ammeter can be short-circuited, posing a grave danger if the LOW terminal and the chassis are short-circuited when part of the DUT is connected to an earth ground.

If it is not known whether the DUTs and jigs are grounded, select the LOW mode. To switch between the two modes, use the SHIFT + F3 keys, regardless of the location of the cursor. Each time the SHIFT + F3 keys are pressed, LOW and GUARD alternate.

Using the ▲▼◀▶ keys, move the cursor to the right of GND; settings can then be made using the rotary knob.

Turn the rotary knob clockwise: GUARD

Turn the rotary knob counterclockwise: LOW

When LOW is selected, the LED to the left of the LOW terminal lights up.

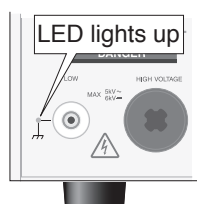

■ LOW

In the LOW mode, the current which flows through the LOW terminal by insulation resistance of the test leadwire and jigs is included in the measurements, as shown in Fig. 3-8 (A) and (B). However, the ammeter is protected from short-circuiting, thereby ensuring safe testing regardless of whether the DUT is grounded. For this reason, it is recommended that LOW be set in ordinary tests.

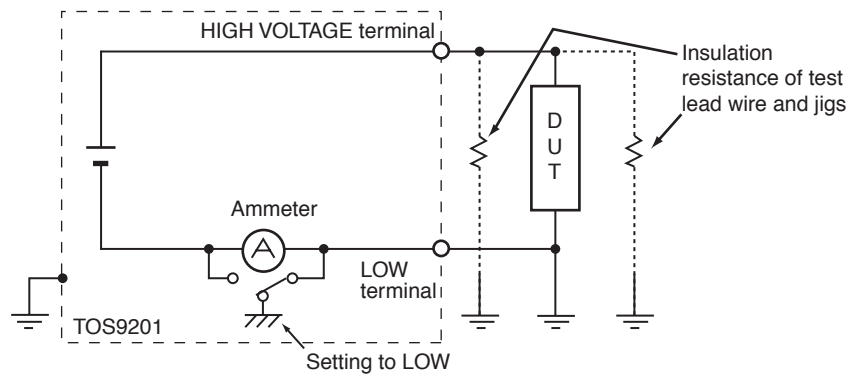

(A) DUT grounded

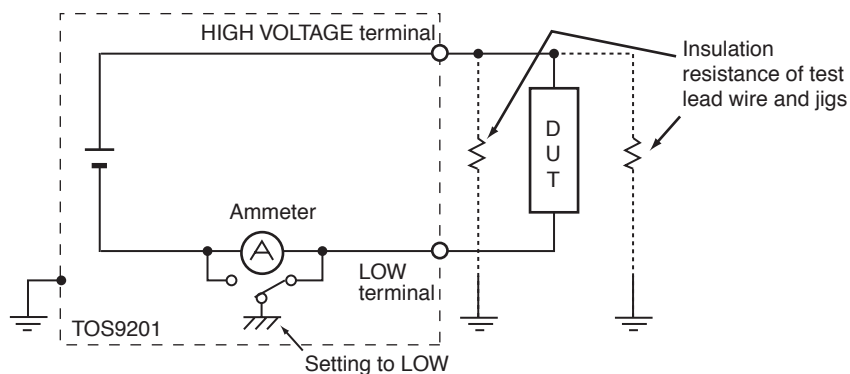

(B) DUT not grounded

Fig.3-8 Selecting LOW

■ GUARD

- ⚠ WARNING**
- If it is not known whether the DUT or jig is grounded, never select GUARD. If GUARD is selected while the DUT is grounded, the ammeter will be short-circuited, thereby disabling measurement and posing a grave danger. See Fig. 3-9 (B).
 - If GUARD is selected, do not connect this tester to any measuring instruments or other devices that involve single-side grounding, such as Kikusui's high-voltage digital voltmeter 149-10A and current calibrator TOS1200. Otherwise, the ammeter will be short-circuited. See Fig. 3-9 (A).

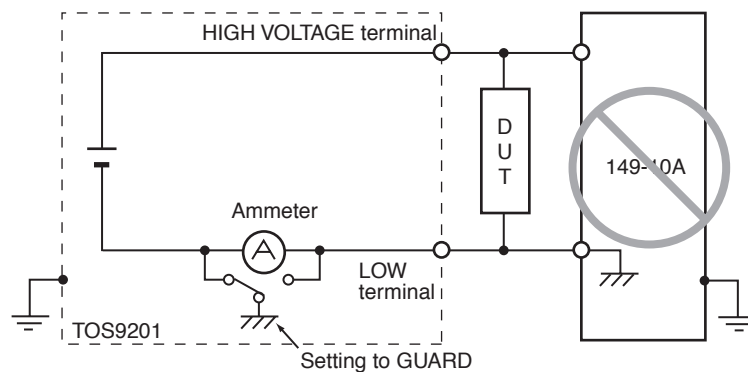

(A) Connecting the 149-10A

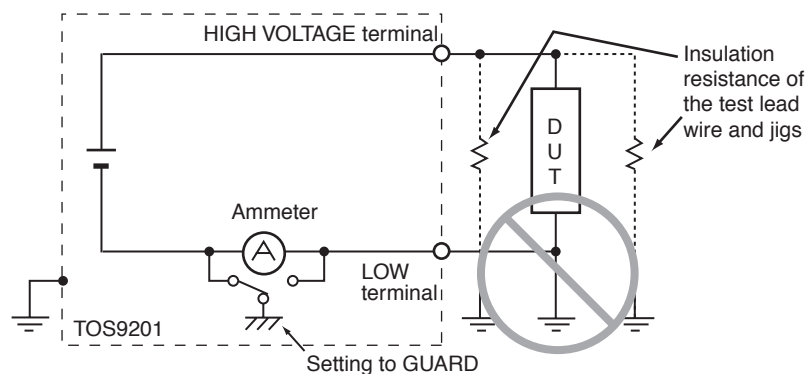

(B) Selecting GUARD when the DUT is grounded

Fig.3-9 Dangerous connection

- ⚠ CAUTION**
- If the LOW terminal of this tester is connected to the HIGH or LOW terminal of the earth continuity tester TOS6200, the ammeter will make measurement errors if GUARD is selected, as the resistor inside the TOS6200 is connected in parallel to the tester's ammeter. Therefore, to use the TOS6200, avoid connecting these terminals, or select LOW.

Select GUARD only when DUTs, such as small electronic components and jigs, are completely “floating” electrically.

As shown in Fig. 3-10, the GUARD mode enables high-sensitivity, high accuracy measurement, as it excludes the current by insulation resistance of the test leadwire and jigs.

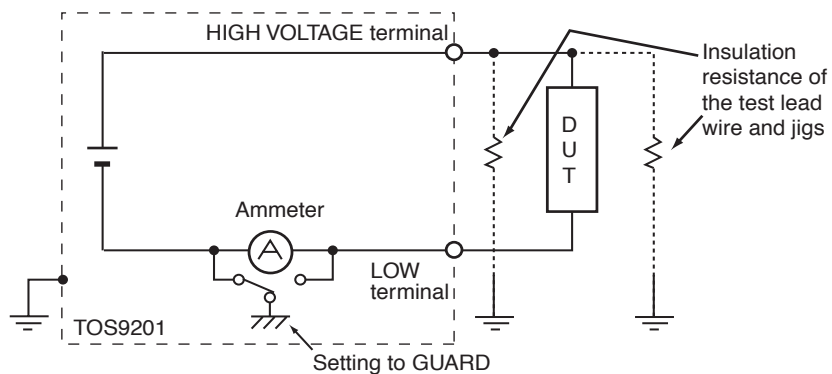
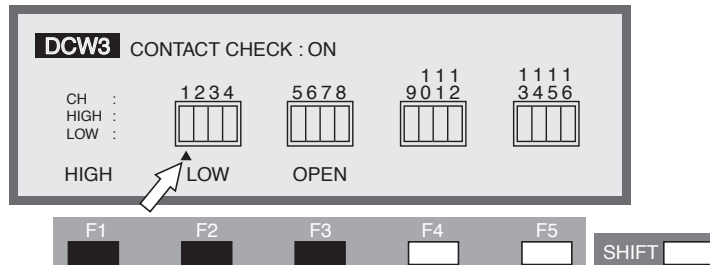

Fig.3-10 Selecting GUARD

3.5.3 Settings on the DCW3 screen

Channel settings for the high-voltage scanner



Make settings with the optional scanner connected.

Each channel can be set to HIGH, LOW, or OPEN.

Use the ◀ ▶ keys to move the cursor (▲) to a channel, and use the F1, F2, and F3 keys to make settings.

If the channel has already been specified, settings can be made using the rotary knob.

The SHIFT + F1 keys can be used to open all channels, regardless of the location of the cursor.

-
- NOTE** • If an unconnected channel is selected, “INVALID CH” flashes on the LCD.

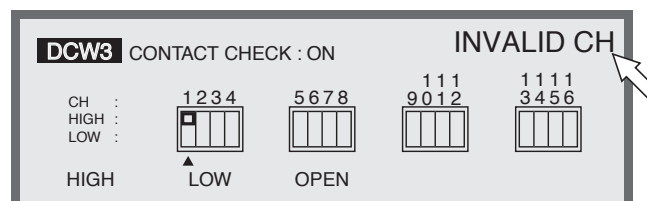

-
- WARNING** • If the test leadwire is not connected to the DUT, do not leave the wire connected to the output terminal on the scanner.

The TOS9220 scanner does not have a contact check function to detect connection to the DUT. If the tester is set to the high-voltage (HIGH) level, a test can be started using a channel with the test leadwire not connected to the DUT.

-
- NOTE** • To clearly indicate the relationships between the connected test leadwire and the channel, affix the Channel Display Seal (provided for the scanner) to the test leadwire.
-

Turning the contact check ON/OFF

When the optional high-voltage scanner TOS9221 (with the contact check function) is connected to the tester, the continuity between the test leadwire and the DUT can be tested using the HIGH or LOW terminal prior to application of a test voltage. To do so, turn on the contact check function.

With the high-voltage scanner TOS9220, a check is conducted on the continuity through to inside of the scanner only.

To turn the contact check function on/off, use the SHIFT + F5 keys.

Each time the SHIFT + F5 keys are pressed, ON and OFF alternate, regardless of the location of the cursor. The cursor moves to CONTACT CHECK.

Using the ▲ key, move the cursor to the right of CONTACT CHECK. Settings can also be made using the rotary knob.

Turn the rotary knob clockwise: ON

Turn the rotary knob counterclockwise: OFF

Press the DCW key to return to the DCW1 screen, and then press the START switch. READY will then disappear from the LCD, and a contact check will start for each channel.

The test starts as soon as the continuity is confirmed.

The test continues until the test time preset on the timer has elapsed or the STOP switch is pressed.

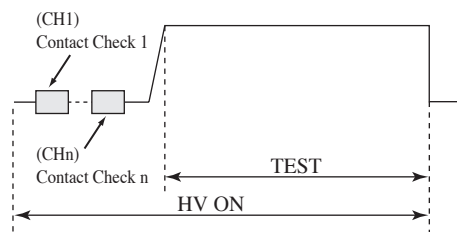
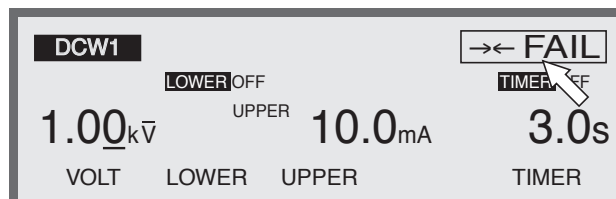

Fig.3-11 Contact check

The contact check time is calculated using the following formula:

Contact check time = 260 ms + 60 ms x (number of channels set to HIGH or LOW)

When a continuity error is detected in a contact check, “ →← FAIL” appears at the top right of the LCD. On the high-voltage scanner, the LED of the failed channel lights up in orange.



3.6 Settings for Insulation Resistance Testing

To make settings for an insulation resistance test, use the Insulation Resistance-Test Setting screen (IR).

To jump to this screen, press the IR key. The LED on the IR key will then light up. The Insulation Resistance-Test Setting screen has three pages from IR1 to IR3.

To move between these pages, press the SHIFT key + ◀ ▶ keys. To return to IR1 from IR2 or IR3, press the IR key.

NOTE

- No setting can be made in the KEYLOCK status.
-

The three IR pages allow the following settings to be made:

IR1

- Test voltage
- Lower resistance (LOWER) and ON/OFF of the lower judgement function
- Upper resistance (UPPER) and ON/OFF of the upper judgement function
- Test time (TEST TIME) and ON/OFF of the timer function

IR2

- Voltage rise time (RISE TIME)
- Judgement wait time (WAIT TIME)
- LOW/GUARD settings for the GND

IR3

- Channel settings for the high-voltage scanner
- ON/OFF of the contact check function

To move the cursor between items, use the ▲ ▼ ◀ ▶ keys.

When a function is shown on the F1 to F5 keys, they can be used to jump to the target item. To conduct the operations displayed on these keys, press the SHIFT key + the F1 to F5 keys.

3.6.1 Settings on the IR1 screen

Setting the insulation resistance test voltage

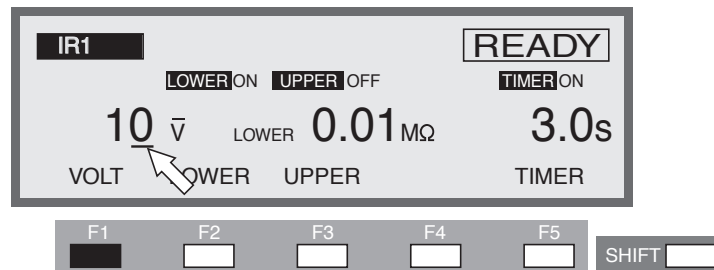

The test voltage to be applied to a DUT can be set to DC –10 V through –1020 V (at a resolution of 1 V). (The negative (-) mark is not displayed.)

To make setting, use the rotary knob with the cursor at the test voltage.

1. To move the cursor to the test voltage, press the F1 key (VOLT). (The ▲ ▼ ◀ ▶ keys can also be used.)
2. Using the ◀ ▶ keys, move the cursor to the target digit.
3. Using the rotary knob, set the test voltage.

NOTE

- With the lower judgement function on, if the test voltage divided by the lower resistance exceeds 1.1 mA, “READY” disappears and “OVER 1.1 mA” flashes at the top right of the LCD to indicate that testing cannot be performed.

In such a case, lower the test voltage or raise the lower resistance.

Turning the lower judgement function ON/OFF

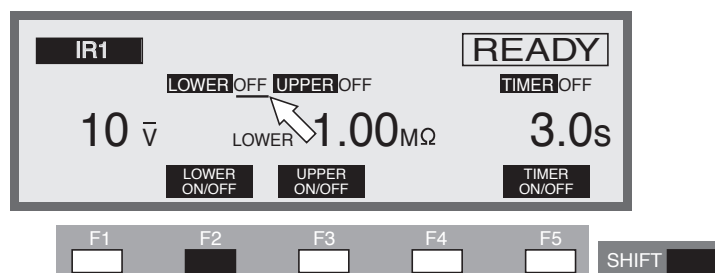

The lower judgement function can be turned on/off.

When the lower judgement function is on, the test ends with a FAIL judgement if the measured insulation resistance drops below the lower resistance.

The lower resistance is explained in the following section.

If the lower judgement function is off, the test ends without a FAIL judgement.

The lower judgement function can be set to ON/OFF using the SHIFT + F2 keys, regardless of the location of the cursor. Each time the SHIFT + F2 keys are pressed, ON and OFF alternate.

The ▲ ▼ ◀ ▶ keys can be used to move the cursor to ON/OFF of the lower judgement function. When the cursor is located at ON/OFF of the lower judgement function, the rotary knob can be used to make settings.

Turn the rotary knob clockwise : ON

Turn the rotary knob counterclockwise : OFF

CAUTION • If the lower and upper judgement function is off, no FAIL judgement is made for that function. Note that a PASS judgement is made when the timer is turned on.

Setting the lower current (LOWER)

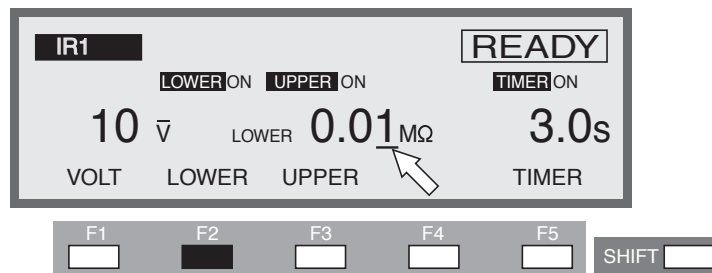

The lower resistance can be set to 0.01 MΩ through 9.99 GΩ (at a resolution of 0.01 MΩ for the 0.01-9.99 MΩ range, 0.1 MΩ for the 10.0 MΩ to 99.9 MΩ range, 1 MΩ for the 100 MΩ to 999 MΩ range, and 0.01 GΩ for the 1.00 GΩ to 9.99 GΩ range), but below the maximum rated current.

When a resistance value at or below the lower resistance is detected following a wait time, the test ends with a FAIL judgement.

When the cursor is at the lower resistance, the rotary knob can be used to make settings.

1. To display the lower resistance, press the F2 key (LOWER). (When the lower resistance is displayed, the cursor can be moved using the ▲ ▼ ◀ ▶ keys.)
2. Using the ◀ ▶ keys, move the cursor to the target digit.
3. Using the rotary knob, set the lower resistance.

NOTE • With both the upper and lower judgement functions on, if the lower resistance is set at or above the upper resistance, “READY” disappears and “UP<=LOW” flashes at the top right of the LCD to indicate that testing cannot be performed. (The lower resistance is factory-set to 1.00 MΩ.)

Reduce the lower resistance or raise the upper resistance.

- With the lower judgement function on, if settings are made so that the test voltage divided by the lower resistance exceeds 1.1 mA, “READY” disappears and

“OVER 1.1 mA” flashes at the top right of the LCD to indicate that testing cannot be performed.

In such a case, lower the test voltage or raise the lower resistance.

- To measure the resistance even when it results in a decrease in the test voltage, turn off the low judgement. In such a case, if the output voltage deviated from the range of the output-voltage monitor function by $\pm(10\%$ of the setting + 50 V), the measured voltage flashes on the LCD voltmeter to warn of a decrease in the test voltage. The test can still be conducted, however.
- No lower judgement is made during the voltage rise time or until the WAIT TIME has elapsed.

Turning the upper judgement function ON/OFF

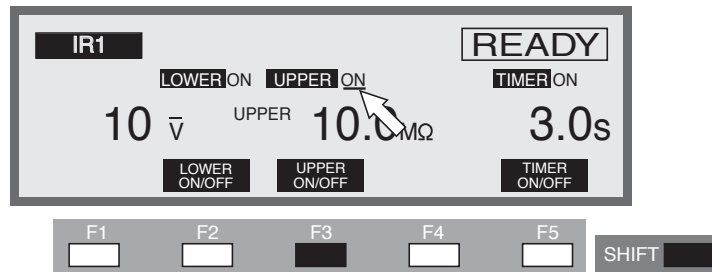

The upper judgement function can be turned on/off.

When the upper judgement function is on, the test ends with a FAIL judgement if the measured resistance exceeds the upper resistance.

The upper resistance is explained in the following section. The upper judgement function can be set to ON/OFF using the SHIFT + F3 keys, regardless of the location of the cursor. Each time the SHIFT + F3 keys are pressed, ON and OFF alternate.

The ▲ ▼ ◀ ▶ keys can be used to move the cursor to ON/OFF of the upper judgement function. If the cursor is at ON/OFF of the upper judgement function, the rotary knob can be used to make settings.

Turn the rotary knob clockwise : ON

Turn the rotary knob counterclockwise : OFF

NOTE

- If the lower and upper judgement functions are off, no FAIL judgement is made. Note that, when the timer is turned on with both functions off, a PASS judgement is made.

Setting the upper current (UPPER)

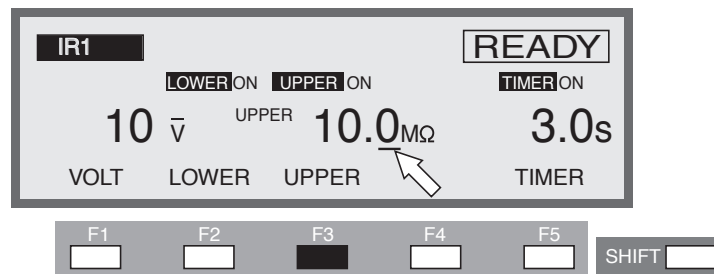

The upper resistance can be set to 0.01 MΩ through 9.99 GΩ (at a resolution of 0.01 MΩ for the 0.01-9.99 MΩ range, 0.1 MΩ for the 10.0 MΩ to 99.9 MΩ range, 1 MΩ for the 100 MΩ to 999 MΩ range, and 0.01 GΩ for the 1.00 GΩ to 9.99 GΩ range), but below the maximum rated current.

When the cursor is at the upper resistance, the rotary knob can be used to make settings.

1. To display the upper resistance, press the F3 key (UPPER). (When the upper resistance is displayed, the cursor can be moved using the ▲ ▼ ◀ ▶ keys.)
2. Using the ◀ ▶ keys, move the cursor to the target digit.
3. Using the rotary knob, set the upper resistance.

NOTE

- With both the upper and lower judgement functions on, if the upper resistance is set at or below the lower resistance, “READY” disappears and “UP<=LOW” flashes at the top right of the LCD to indicate that testing cannot be performed. (The upper resistance is factory-set to 100 MΩ.)

Raise the upper resistance, reduce the lower resistance, or turn off the lower judgement function.

- With the upper judgement function on, if settings are made so that the test voltage divided by the upper resistance exceeds 1.1 mA, “READY” disappears and “OVER 1.1 mA” flashes at the top right of the LCD to indicate that testing cannot be performed.

In such a case, lower the test voltage or raise the upper resistance.

Turning the timer ON/OFF

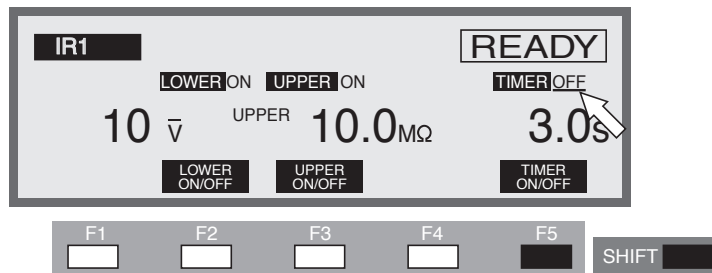

Make ON/OFF settings for the timer function.

When the timer function is turned on, the test time can be controlled as specified in “Setting the test time” in the next section. When the preset test time has elapsed with the resistance recorded between the lower and upper resistances, the test ends with a PASS judgement.

The timer function can be set to ON/OFF using the SHIFT + F5 keys, regardless of the location of the cursor. Each time the SHIFT + F5 keys are pressed, ON and OFF alternate.

The ▲ ▼ ◀ ▶ keys can also be used to move the cursor to ON/OFF of the timer function. If the cursor is at ON/OFF of the timer function, the rotary knob can be used to make settings.

Turn the rotary knob clockwise : ON

Turn the rotary knob counterclockwise : OFF

Setting the test time (TEST TIME)

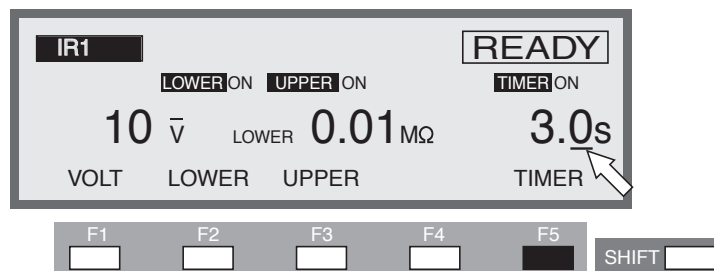

The time during which a preset voltage is applied to the DUT can be set to between 0.5 s and 999 s (at a resolution of 0.1 s for the 0.5 s to 99.9 s range and 1 s for the 100 s to 999 s range).

When the cursor is at TIMER, the rotary knob can be used to make settings.

1. To move the cursor to TIMER, press the F5 key (TIMER). (The ▲ ▼ ◀ ▶ keys can also be used.)
2. Using the ◀ ▶ keys, move the cursor to the target digit.
3. Using the rotary knob, set the test time.

3.6.2 Settings on the IR2 screen

Setting the voltage rise time (RISE TIME)

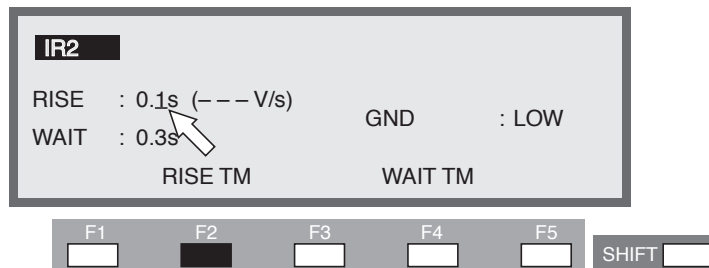

The rise time between the start voltage and the test voltage can be set to 0.1 s through 200 s (at a resolution of 0.1 s for the 0.1 s to 99.9 s range and 1 s for the 100 s to 200 s range).

When the cursor is to the right of RISE, settings can be made using the rotary knob.

1. To move the cursor to RISE, press the F2 key (RISE TM). (The ▲ ▼ ◀ ▶ keys can also be used.)
2. Using the ◀ ▶ keys, move the cursor to the target digit.
3. Using the rotary knob, set the rise time.

The figure (V/s) in parentheses represents the voltage increase per second calculated for reference using the set value.

If the value cannot be displayed in three digits, "---" is displayed instead.

Setting the WAIT TIME

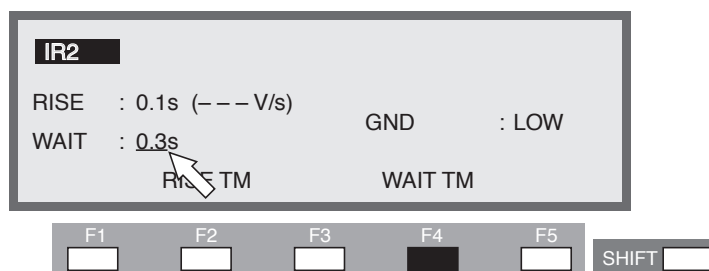

In DC insulation resistance testing, if a test voltage is applied to a DUT that contains capacitive elements, the measured insulation resistance will be below the optimal value due to a charge current, until charging is completed. To avoid upper fail judgement by the charge current, a wait time must be provided from the starts of START VOLTAGE, and upper fail judgement will be ignored during wait time.

Set the wait time to 0.3 s through 10 s (at a resolution of 0.1 s).

When the cursor is located to the right of WAIT, the rotary knob can be used to make settings.

1. To move the cursor to the right of WAIT, press the F4 key (WAIT TM). (The ▲ ▼ ◀ ▶ keys can also be used.)
2. Using the rotary knob, set the wait time.

NOTE

- With the timer ON, if the wait time thus set exceeds the sum of the voltage rise time and the test time, “OVER WAIT” flashes on the LCD to indicate that testing cannot be performed.

Setting LOW/GUARD for the GND

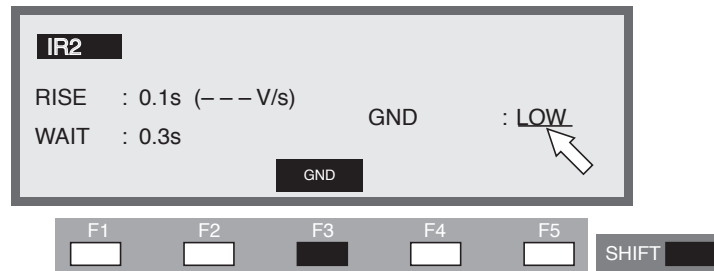

You can select either of the following two measurement modes;

- the LOW mode that the GND is connected to the tester’s LOW terminal,
- the GUARD mode that the GND is used as guard.

In both modes, the tester detects the current flowing into the LOW terminal from the HIGH VOLTAGE terminal via the DUT. In the LOW mode, the LOW terminal is connected to the chassis. This leads to the problem of the insulation resistance between the test leadwire and jigs and the earth being included in the measurement. Nonetheless, the GND mode ensures safe testing, as it does not short-circuit the ammeter.

In the GUARD mode, on the other hand, only the current flowing into the LOW terminal from the HIGH VOLTAGE terminal via the DUT is measured, while the influence of the insulation resistance between the test leadwire and jigs and the earth is eliminated. For this reason, the GUARD mode is effective in measurements that require high sensitivity and high accuracy. At the same time, however, the ammeter can be short-circuited, posing a grave danger if the LOW terminal and the chassis are short-circuited when part of the DUT is connected to the earth ground. If it is not known whether the DUTs and jigs are grounded, select the LOW mode.

To switch between the two modes, use the SHIFT + F3 keys, regardless of the location of the cursor. Each time the SHIFT + F3 keys are pressed, LOW and GUARD alternate.

Using the ▲▼◀▶ keys, move the cursor to the right of GND; settings can then be made using the rotary knob.

Turn the rotary knob clockwise : GUARD

Turn the rotary knob counterclockwise : LOW

When LOW is selected, the LED to the left of the LOW terminal lights up.

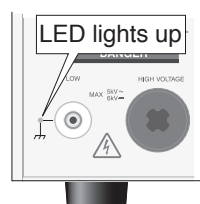

■ LOW

In the LOW mode, the insulation resistance of the test leadwire and jigs is included in measurements, as shown in Fig. 3-12 (A) and (B). However, the ammeter is protected from short-circuiting, ensuring safe testing regardless of whether the DUT is grounded. For this reason, it is recommended that LOW be set in ordinary tests.

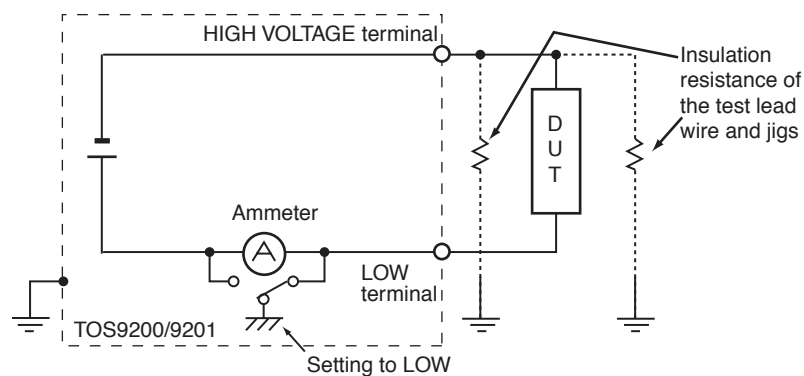
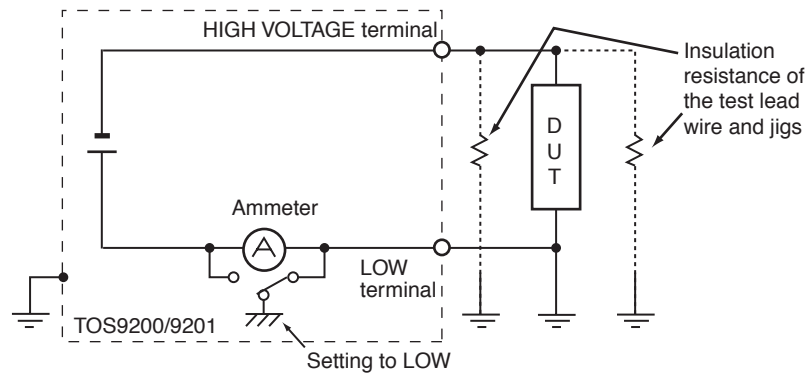
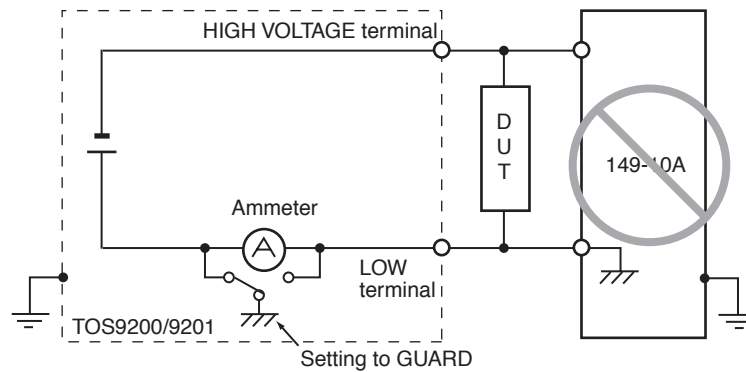

Fig.3-12 Selecting LOW

■ GUARD

- ⚠ WARNING**
- If it is not known whether the DUT or jig is grounded, never select GUARD. If GUARD is selected while the DUT is grounded, the ammeter will be short-circuited, disabling measurement and posing a grave danger. See Fig. 3-13 (B).
 - If GUARD is selected, do not connect this tester to any measuring instruments or other devices that involve single-side grounding, such as Kikusui's high-voltage digital voltmeter 149-10A or current calibrator TOS1200. Otherwise, the ammeter will be short-circuited. See Fig. 3-13 (A).



(A) Connecting the 149-10A

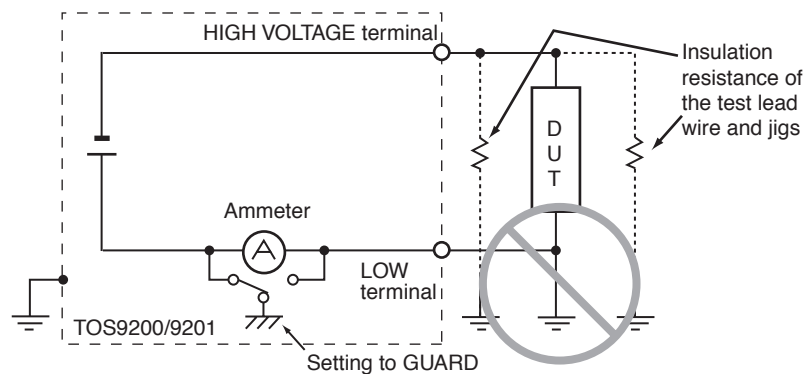

(B) Selecting GUARD when the DUT is grounded

Fig.3-13 Dangerous connection

- CAUTION**
- If the LOW terminal of this tester is connected to the HIGH or LOW terminal of the earth continuity tester TOS6200, the ammeter will make measurement errors if GUARD is selected, as the resistor inside the TOS6200 is connected in parallel to the tester's ammeter. Therefore, to use the TOS6200, avoid connecting these terminals, or select LOW.

Select GUARD only when DUTs, such as small electronic components and jigs, are completely “floating” electrically.

As shown in Fig. 3-14, the GUARD mode enables high-sensitivity, high accuracy measurement, as it excludes the insulation resistance of the test leadwire and jigs.

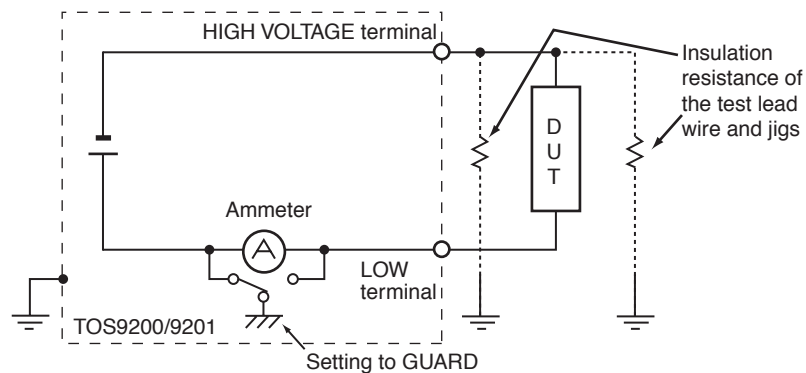
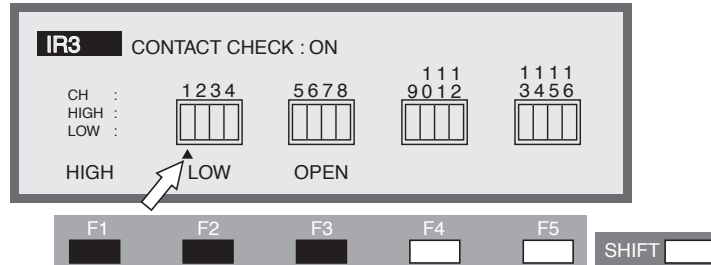

Fig.3-14 Selecting GUARD

3.6.3 Settings on the IR3 screen

Channel settings for the high-voltage scanner



Make settings when the optional scanner is connected.

Each channel can be set to HIGH, LOW, or OPEN.

Use the ◀ ▶ keys to move the cursor (▲) to a channel, and use the F1, F2 and F3 keys to make settings.

If the channel has already been specified, settings can be made using the rotary knob.

Using the SHIFT + F1 keys, all channels can be opened regardless of the location of the cursor.

-
- NOTE** • If an unconnected channel is selected, “INVALID CH” flashes on the LCD.

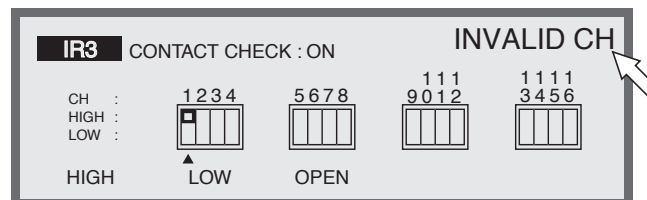

-
- WARNING** • If the test leadwire is not connected to the DUT, do not leave the wire connected to the output terminal on the scanner.

The TOS9220 scanner does not have a contact check function to detect connection to the DUT. If the tester is set to the high-voltage (HIGH) level, a test can be started using a channel with the test leadwire not connected to the DUT.

-
- NOTE** • To clearly indicate the relationships between the connected test leadwire and the channel, affix the Channel Display Seal (provided for the scanner) to the test leadwire.
-

Turning the contact check ON/OFF

When the optional high-voltage scanner TOS9221 (with the contact check function) is connected to the tester, the continuity between the test leadwire and the DUT with the HIGH or LOW terminal can be checked prior to the application of a test voltage. To do so, turn on the contact check function.

With the high-voltage scanner TOS9220, a check is conducted on the continuity through to inside of the scanner only.

Use the SHIFT + F5 keys to turn the contact check function on/off.

Each time the SHIFT + F5 keys are pressed, ON and OFF alternate, regardless of the location of the cursor. The cursor moves to CONTACT CHECK.

Using the ▲ key, move the cursor to the right of CONTACT CHECK. Settings can also be made using the rotary knob.

Turn the rotary knob clockwise : ON

Turn the rotary knob counterclockwise : OFF

Press the IR key to return to the IR1 screen, and then press the START switch.

READY then disappears on the LCD, and a contact check starts for each channel.

The test starts as soon as the continuity is confirmed, and continues until the test time preset on the timer has elapsed or the STOP switch is pressed.

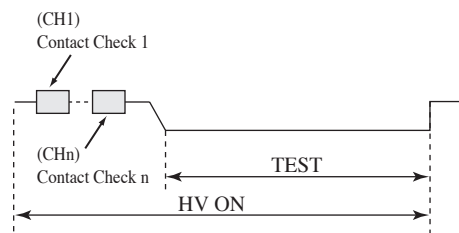
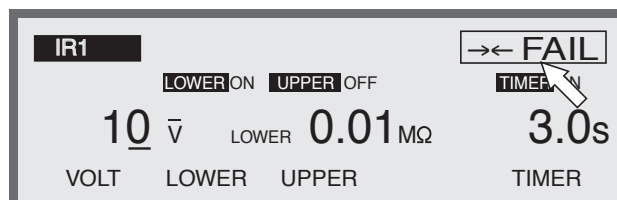

Fig.3-15 Contact check

The contact check time is calculated using the following formula:

Contact check time = 260 ms + 60 ms x (number of channels set to HIGH or LOW)

When a continuity error is detected in a contact check, “ →← FAIL” appears at the top right of the LCD. On the high-voltage scanner, the LED of the failed channel lights up in orange.



3.7 Connecting the Test Leadwire

⚠ WARNING • It is extremely dangerous to connect the test leadwire incorrectly, as the DUT may be charged to an excessively high voltage. Be sure to make connections securely.

3.7.1 Connecting the test leadwire to the tester

■ Connecting the low-voltage test leadwire

1. Check for a disconnection in the test leadwire.
2. Connect the low-voltage test leadwire to the tester's LOW terminal.

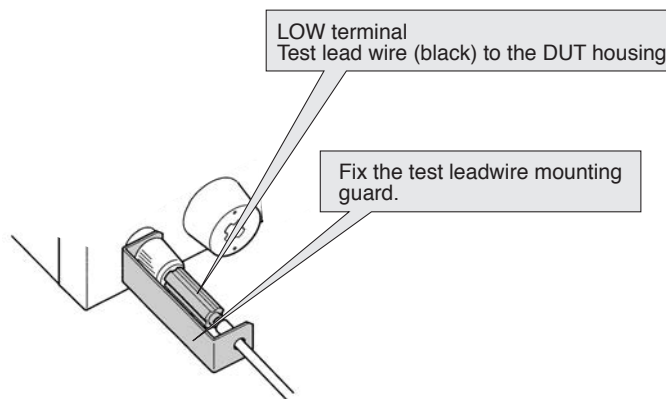

Fig.3-16 Connecting the low-voltage test leadwire

■ Connecting the high-voltage test leadwire

After connecting the low-voltage test leadwire, follow the procedure specified below.

Connection procedure

1. Press the STOP switch.
2. Confirm that the analog voltmeter indicates "0."
3. Confirm that the DANGER lamp is off.
4. Connect the high-voltage test leadwire to the HIGH VOLTAGE terminal.
5. Short-circuit the low-voltage and high-voltage test leadwires, and confirm that no high voltage is output.

3.7.2 Connecting a DUT

After connecting the low-voltage and high-voltage test leadwires, connect a DUT by following the procedure specified below.

Connection procedure

1. Press the STOP switch.
2. Confirm that the analog voltmeter indicates “0.”
3. Confirm that the DANGER lamp is off.
4. Short-circuit the low-voltage and high-voltage test leadwires, and confirm that no high voltage is applied.
5. Connect the low-voltage test leadwire to the DUT.
6. Connect the high-voltage test leadwire to the DUT.

⚠ WARNING • During the test (the TEST lamp or DANGER lamp is lit), never touch the HIGH VOLTAGE terminal, test leadwire, or DUT.

■ Reducing the effects of noise

If a short circuit or breakdown occur, noise generated can lead to the malfunctioning of peripheral electronic components. To reduce the effects of noise, install a toroidal core or a resistor of approximately $470\ \Omega$ between the DUT and the end of the high-voltage test leadwire from the tester, and between the DUT and the end of the low-voltage test leadwire, as close as possible to the DUT. See Fig. 3-17.

Using a toroidal core, it is recommended that a divisible core be used for power cable with a diameter of approximately 20 mm, and that it be wound two or three times around the core.

When connecting a resistor, check its power rating. For an upper current of 10 mA or less, use a resistor of approximately $470\ \Omega$ (3 W, impulse withstanding voltage of 30 kV). When such a resistor is connected, the voltage actually applied to the DUT is slightly smaller than the output-terminal voltage (approximately 10 V less at 10 mA) due to a voltage drop caused by the resistor. This type of resistor is highly useful in reducing the effects of noise.

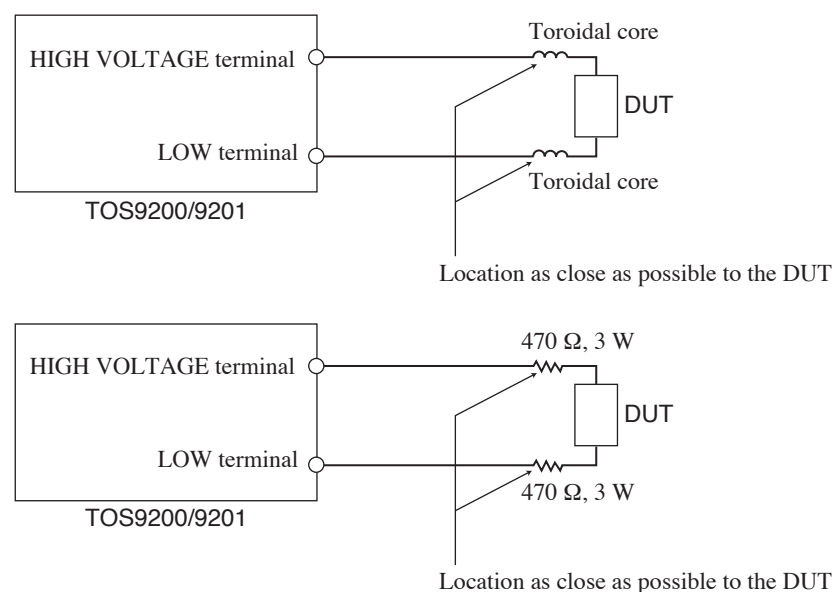

Fig.3-17 Reducing the effects of noise

3.8 Starting and Ending a Test

NOTE

- The test cannot be started with invalid settings or in the protection status. For information on invalid settings and the protection status, see "3.15 Invalid Settings" and "3.16 Protection".
- The test cannot be started while the STOP switch is pressed. (The test also cannot be started when the STOP signal of remote control is active.)
- If the DOUBLE ACTION is on, press the START switch within approximately 0.5 seconds after pressing the STOP switch, as the test will not start otherwise. For details on DOUBLE ACTION, see "3.10 System Settings".
- If the MOMENTARY function is ON, the test runs only while the START switch is pressed. For details on MOMENTARY, see "3.10 System Settings".

3.8.1 Starting a test

To start a test, press the START switch when the tester is in the READY status on the Test-Condition Settings screen. When the tester is in the READY status, "READY" lights up at the top right of the LCD.

Example of an AC withstanding voltage test (READY)

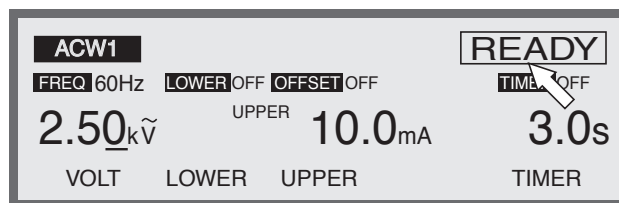

As soon as the test starts, the LCD displays the following:

During the test, "TEST" is displayed at the top right of the LCD, and the TEST LED and DANGER lamp light up on the indicator. (During a voltage rise, "TEST" flashes at the top right of the LCD.)

Example of an AC withstanding voltage test (TEST)

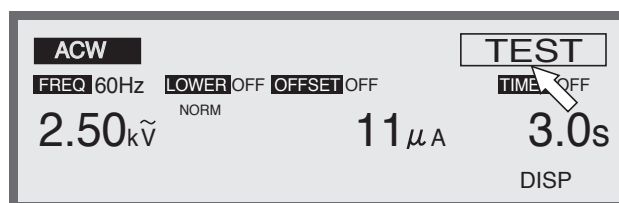

The time is displayed differently depending on whether the timer function is on or off.

The timer is ON : The remaining test time is displayed.

The timer is OFF : The elapsed test time is displayed.

(When 999 seconds have elapsed, "999" flashes.)

If the key is not locked, the test voltage can be changed during the test using the rotary knob.

The cursor moves to the 2nd decimal place in ACW and IR, and to the 1st decimal place in DCW.

NOTE

- In an AC withstanding voltage test with the output voltage range set to AUTO, if the test starts with the test voltage set to 2.60 kV or less, the voltage cannot be reset to 2.60 kV or more during the test.
- If the test voltage is changed when the measured current is close to the upper current, the test may end with a FAIL judgement.

Screens can be switched during the test using the F5 key (DISP). To suspend the test, press the STOP switch.

Example of an AC withstanding voltage test (DISP1)

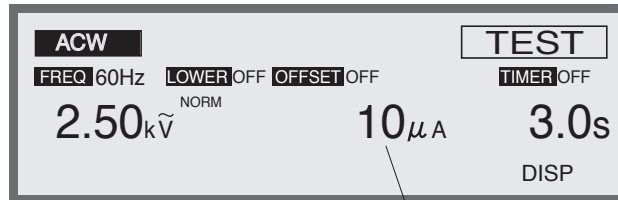

Absolute value of measured current

Example of an AC withstanding voltage test (DISP2)

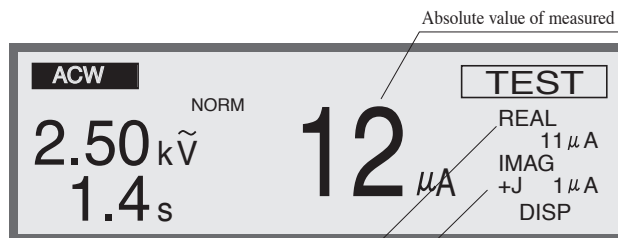

Absolute value of measured current

Real-value portion of the measured current

Imaginary-value portion of the measured current

Example of a DC withstanding voltage test (DISP1)

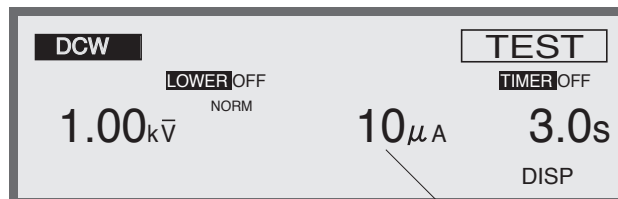

Measured current

Example of a DC withstanding voltage test (DISP2)



Example of an insulation resistance test (DISP1)

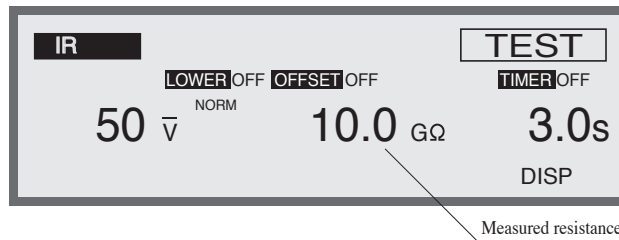

Example of an insulation resistance test (DISP2)

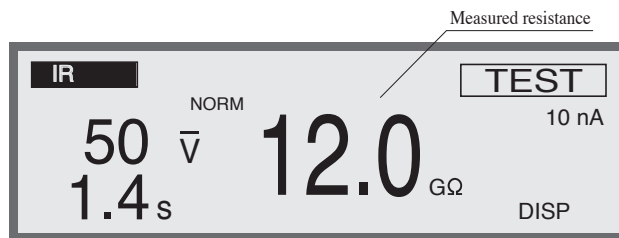

NOTE

- In insulation resistance testing, when the resistance value to exceed 99.9 GΩ is detected, “99.9” flashes on the LCD.
 - In insulation resistance testing with the lower judgment function off, even if settings are made so that the test voltage divided by the lower resistance exceeds 1.1 mA, testing can be performed. However, when the voltage value which is out of the range of ±(10 % of setting +50 V) is detected during the test, the measurement voltage value flashes on the LCD.
-

3.8.2 Ending the test

PASS judgement

Example of an AC withstanding voltage test (PASS)

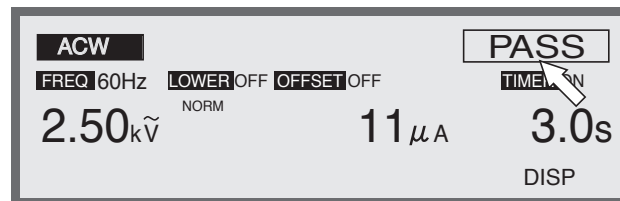

When the timer is ON:

When the test time has elapsed without the occurrence of the FAIL status, the test ends with a PASS judgement.

When a PASS judgement is made, “PASS” appears at the top right of the LCD, the PASS LED lights on the indicator, and a buzzer sounds. The PASS judgement is displayed for approximately 0.2 seconds (by default). The display time for the PASS judgement can be set to 0.2 s through 10.0 s or to HOLD. The buzzer action synchronizes with the PASS display time. For the setting procedure, see "3.10 System Settings".

The measurement results are displayed while “PASS” is displayed.

When “PASS HOLD” is not set to “HOLD,” the tester automatically returns to the READY status after a PASS judgement is made.

When the timer is OFF:

The test continues until the FAIL conditions are met.

Press the STOP switch to suspend the test. The test does not make a judgement and “PASS” is not displayed.

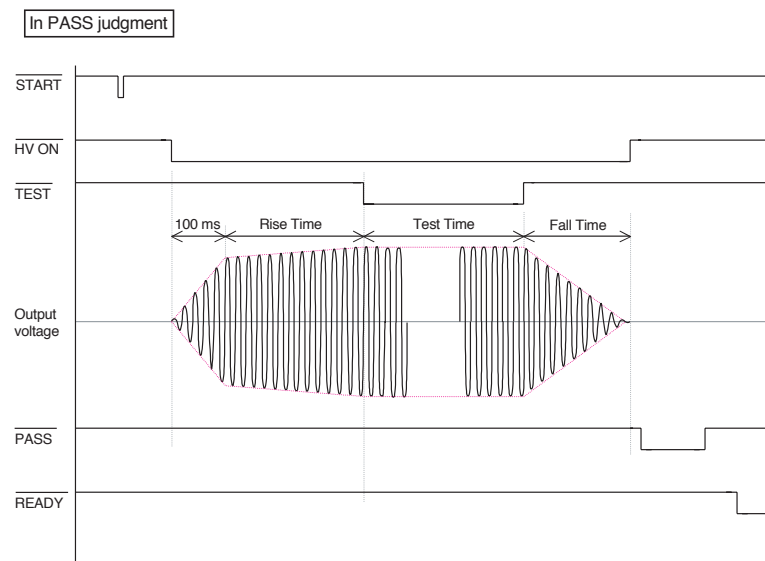

Fig.3-18 Timing chart for PASS judgement
(The start voltage is set on the ACW.)

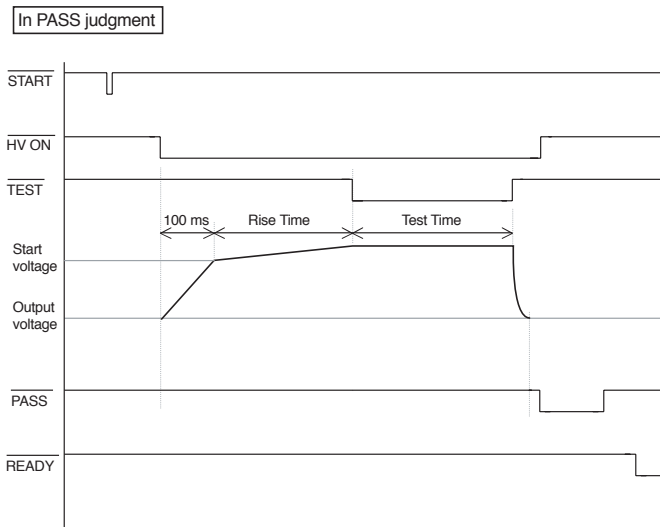

Fig.3-19 Timing chart for PASS judgement
(The start voltage is set on the DCW.)

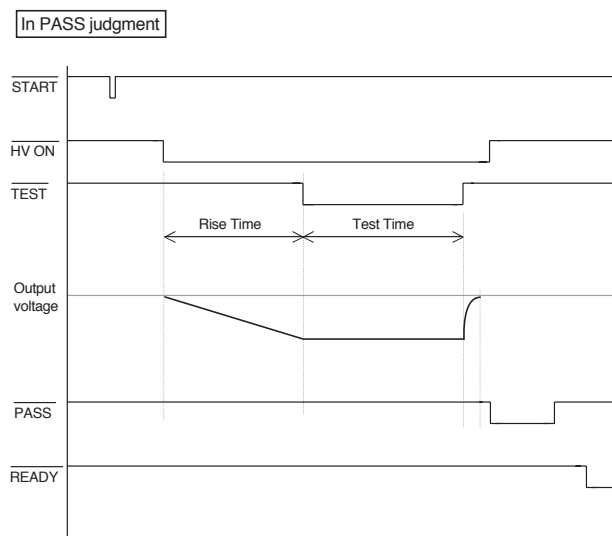

Fig.3-20 Timing chart for PASS judgement (IR)

FAIL judgement

Example of an AC withstanding voltage test (FAIL)



■ AC/DC withstanding voltage testing

If the lower judgement function is off, the test ends with a FAIL judgement when a current larger than the upper current is detected. After a few milliseconds, the power is then cut off.

If the lower judgement function is on, the test ends with a FAIL judgement when the tester detects a current larger than the upper current or a current smaller than the lower current. After a few milliseconds, the power is then cut off.

When lower and upper judgements are made, “ ↓ FAIL” and “ ↑ FAIL” appear, respectively, at the top right of the LCD.

At the same time, the FAIL LED lights on the indicator and a buzzer sounds. To cancel the FAIL judgement, press the STOP switch (the FAIL judgement is output until the STOP switch is pressed).

The measurement results are displayed until the STOP switch is pressed.

The FAIL judgement other than that described above is a CONTACT FAIL (“ →← FAIL”) judgement that is made when the contact failure is detected while a scanner is used.

NOTE

- In AC withstanding voltage testing, a lower judgement is not made during a voltage rise time (RISE TIME) or a voltage fall time (FALL TIME).
 - In DC withstanding voltage testing, no lower judgement is made during a voltage rise time (RISE TIME).
 - In DC withstanding voltage testing, an upper judgement is not made until the WAIT TIME has elapsed to eliminate the effects of a charge current in capacitive DUTs.
-

■ Insulation resistance testing

If the upper judgement function is on, the test ends with a FAIL judgement when a resistance larger than the upper resistance is detected. After a few milliseconds, the power is then cut off.

If the lower judgement function is on, the test ends with a FAIL judgement when the tester detects a resistance smaller than the lower resistance. After a few milliseconds, the power is then cut off.

Using a lower and upper judgement, “ ↓ FAIL” and “ ↑ FAIL” appear, respectively, at the top right of the LCD. At the same time, the FAIL LED lights up on the indicator and a buzzer sounds.

To cancel the FAIL judgement, press the STOP switch (the FAIL judgement is output until the STOP switch is pressed).

The measurement results are displayed until the STOP switch is pressed.

The FAIL judgement other than that described above is a CONTACT FAIL (“ →← FAIL”) judgement that is made when the contact failure is detected while a scanner is used.

NOTE

- In insulation resistance testing, an upper judgement is not made during a voltage rise time (RISE TIME).
 - In insulation resistance testing, a lower judgement is not made until the WAIT TIME has elapsed to eliminate the effects of a charge current in capacitive DUTs.
-

Interruption by a FAIL judgment

ACW

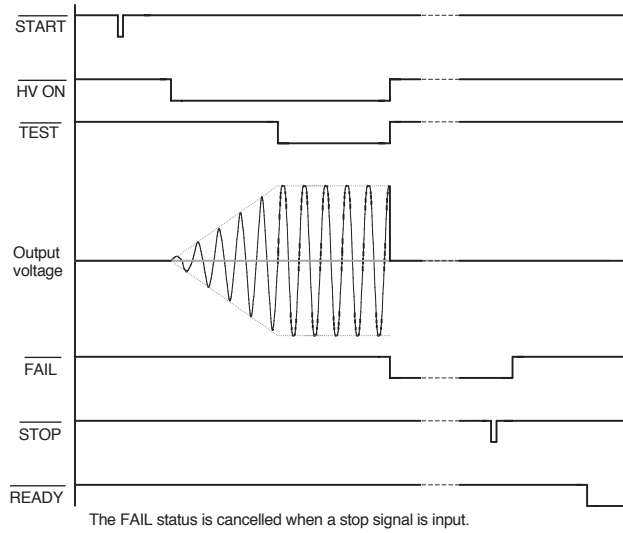

Fig.3-21 Timing chart for the FAIL judgement (ACW)

Interruption by a FAIL judgment

DCW

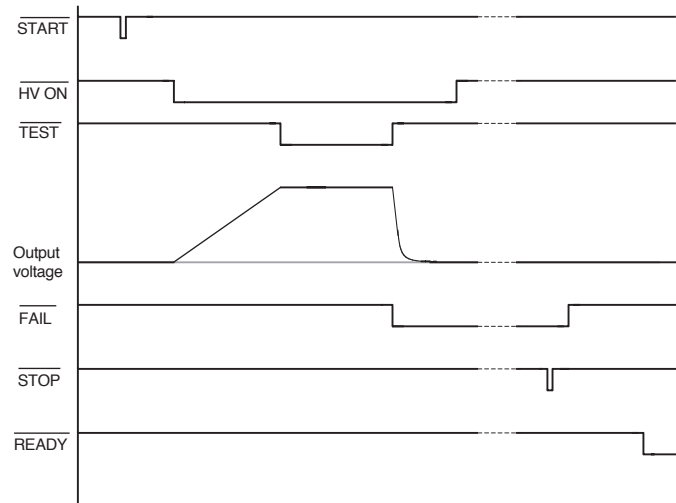

Fig.3-22 Timing chart for the FAIL judgement (DCW)

Interruption by a FAIL judgment

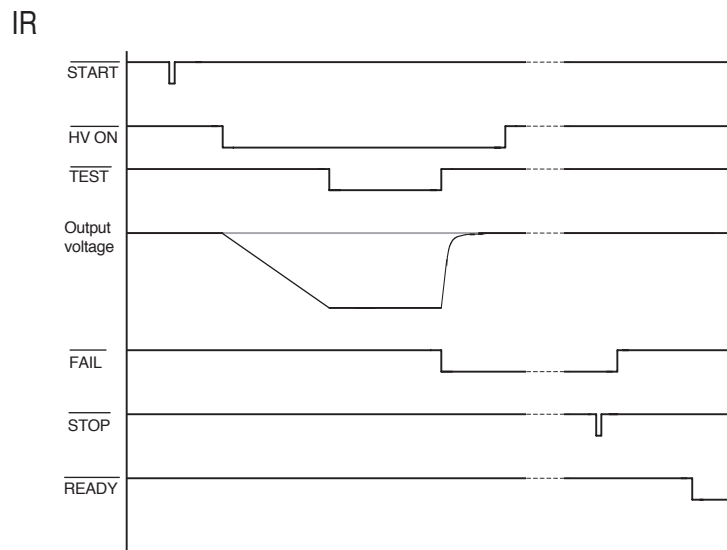

Fig.3-23 Timing chart for the FAIL judgement (IR)

3.9 Offset Cancel Function

The offset cancel function is used to measure the current flowing as insulation resistance, stray capacity in the test leadwire, and jigs in AC withstanding voltage testing. The results are subtracted such current from the measurement results of the testing.

To activate the offset cancel function, open the end of the test leadwire. From the measured current, separate the real-number portion (REAL) and the imaginary-number portion (IMAG.) Save these numbers as offset values.

Measure offset values under actual test conditions. If conditions are modified in an actual test, irrelevant offset values would be used for subtraction. Particularly when the frequency, the scanner, or the LOW/GUARD settings for the GND, which affect the capacitive element, are changed, the offset cancel operation must be repeated.

When the test voltage is changed, however, it is not necessary to repeat the offset cancel operation, as the offset value for deduction is converted to suitable value according to test voltage.

An offset cancel operation reflects the test voltage, test frequency, test time, ON/OFF settings for the timer, LOW/GUARD settings for the GND, and settings for the high-voltage scanner in AC withstanding voltage testing.

NOTE

- To ensure high-sensitivity measurement, avoid moving the test leadwire. The stray capacity depends on the status of the test leadwire. To obtain actual offset values, it is recommended that measurements be conducted under actual test conditions.
- Once the real-number portion and imaginary-number portion of the measured current exceed $500 \mu\text{A}$ at 5 kV and $100 \mu\text{A/kV}$, the tester flashes the measured current to indicate that it is impossible to cancel the offset function. When a current exceeding $550 \mu\text{A}$ is detected, the test ends with a FAIL judgement.

When the measured current flashes, recheck the cable connections in order to reduce the stray capacity, and then reactivate the offset cancel function.

Offset cancel procedure

1. Connect cables exactly as they are connected in an actual AC withstanding voltage test, but remove the DUT.
2. On the ACW1 screen, set the lower judgement function to OFF.
3. Using the SHIFT + ACW/OFFSET keys, shift to the offset measurement screen (OFFSET). The screen displays the test voltage, test frequency, test time, and the on/off settings for TIMER exactly as they were on the previous screen.



4. When necessary, set the test voltage, test frequency, and test time. For the setting procedures, see "3.4 Settings for AC Withstanding Voltage Testing".
5. When "READY" (READY status) is displayed on the offset measurement screen (OFFSET), press the START switch; offset measurement then starts.

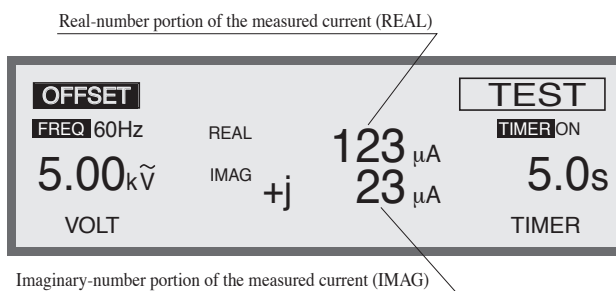

The tester saves the offset value that is valid when the STOP-switch is pressed or the preset timer time has elapsed. Upon completion of the offset measurement, the tester returns to the READY status.

On the ACW1 screen, if OFFSET is set to ON, the test result is the value obtained by subtracting the offset value measured above from the measured current.

To check the offset value, press the SHIFT + ACW/OFFSET keys in order to return to the offset measurement screen (OFFSET).

3.10 System Settings

To display the system setting screen (SYSTEM), press the SYSTEM key. The LED on the SYSTEM key lights up.

The system settings screen (SYSTEM) is composed of four pages – SYSTEM1 to SYSTEM4. To switch among these pages, press the SHIFT key + ◀ ▶ keys.

Settings can be made for the following items:

SYSTEM1

- Measurement-mode (MEAS MODE) settings
- Pass hold-time (PASS HOLD) settings
- Turning ON/OFF the momentary function (MOMENTARY)
- Turning ON/OFF the FAIL mode (FAIL MODE)
- Turning ON/OFF the double-action function (DOUBLE ACTION)

SYSTEM2

- Buzzer-volume (BUZZER) settings
- Contrast (CONTRAST) settings

SYSTEM3

- STATUS-SIGNAL OUTPUT settings

SYSTEM4

- Inputting a comment (COMMENT)

3.10.1 SYSTEM 1

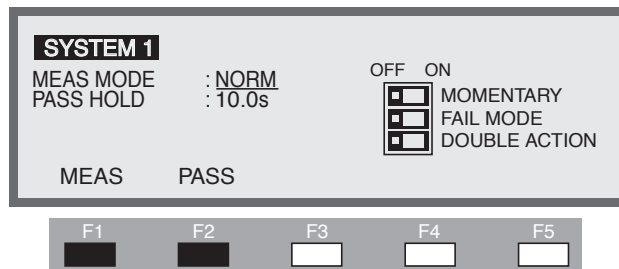

Setting the measurement mode (MEAS MODE)

A leakage-current measurement mode can be selected.

NORM : Ordinary measurement mode

MIN/MAX : The measurement mode for holding the maximum current in withstanding voltage testing and the minimum resistance recorded after the WAIT TIME has elapsed in insulation resistance testing

1. Using the F1 key (MEAS) or the ▲ ▼ ◀ ▶ keys, move the cursor to MEAS MODE.
2. Using the rotary knob, select NORM or MIN/MAX.

Setting the pass hold time (PASS HOLD)

The hold time can be set to 0.2 s through 10.0 s (at a resolution of 0.1 s) for a PASS judgement.

When HOLD is set, a PASS judgement is held until the STOP switch is pressed.

1. Using the F2 key (PASS) or the ▲ ▼ ◀ ▶ keys, move the cursor to PASS HOLD.
2. Using the rotary knob, set the pass hold time.

Turning the momentary function ON/OFF (MOMENTARY)

NOTE

- Releasing the START switch with MOMENTARY on is equivalent to pressing the STOP switch. As a result, in a programmed automatic test, the test is unable to proceed to the next step if the step interval time is set to HOLD.

When MOMENTARY is on, the test continues as long as the START switch is held down.

When MOMENTARY is set to ON, the tester performs a test only for as long as the START switch remains pressed. Since this operation keeps the operator's hands confined to the front panel of the tester or the optional START switch during a test,

it increases the safety of operations. Use of this function together with the optional RC02-TOS (a remote-control box operated using both hands) further increases safety.

The momentary function can be set using the SHIFT + F1 keys, regardless of the location of the cursor. Each time the SHIFT + F1 keys are pressed, ON and OFF alternate. The ► mark on the screen is to the left of MOMENTARY.

When the ► mark is to the left of MOMENTARY, settings can be made using the rotary knob.

Turn the rotary knob clockwise : ON

Turn the rotary knob counterclockwise : OFF

When ON is set, items are highlighted.

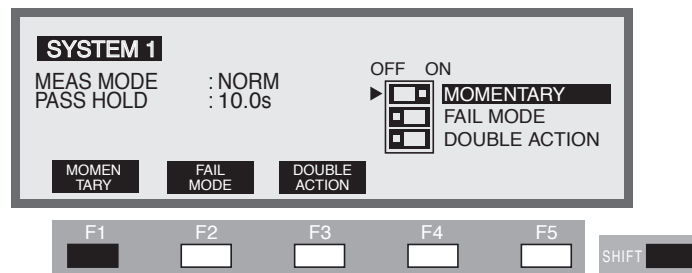

Turning the FAIL mode ON/OFF (FAIL MODE)

When the FAIL mode is on, it is impossible to cancel a FAIL judgement or the protection status using the STOP signal by remote control.

To use the optional high-voltage test probe (HP01-TOS, HP02-TOS), turn on the FAIL mode. When the test ends with a FAIL judgement, the tester's FAIL status is not cancelled even if you release your hand from the probe. To cancel the FAIL status, press the STOP switch on the front panel.

The FAIL mode can be set using the SHIFT + F2 keys, regardless of the location of the cursor. Each time the SHIFT + F2 keys are pressed, ON and OFF alternate. The ► mark on the screen is to the left of FAIL MODE.

When the ► mark is to the left of MOMENTARY, settings can be made using the rotary knob.

Turn the rotary knob clockwise : ON

Turn the rotary knob counterclockwise : OFF

Turning the double-action function ON/OFF (DOUBLE ACTION)

When the double-action function is set to ON, a test cannot be started unless the START switch is pressed within approximately 0.5 s after the STOP switch is pressed (“READY” disappears approximately 0.5 s after the STOP switch is pressed).

To start a test, not only the START switch but also the STOP switch must be pressed. This bothersome operation is intended to enhance safety.

To control the tester using the GPIB or RS-232C, turn off this function.

The double-action function can be set using the SHIFT + F3 keys, regardless of the location of the cursor. Each time the SHIFT + F3 keys are pressed, ON and OFF alternate. The ► mark on the screen appears to the left of DOUBLE ACTION.

When the ► mark is to the left of DOUBLE ACTION, settings can be made using the rotary knob.

Turn the rotary knob clockwise : ON

Turn the rotary knob counterclockwise : OFF

3.10.2 SYSTEM2

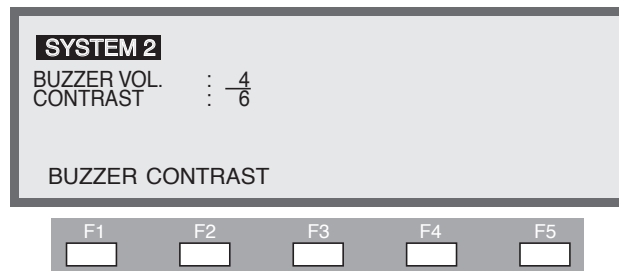

Setting the buzzer volume (BUZZER)

The buzzer volume can be set to 0 through 10 (at a resolution of 1) for FAIL judgement. The buzzer volume for PASS judgement is half that for FAIL judgement.

1. To display the BUZZER VOL., press the SHIFT + ◀ ▶ keys to display the SYSTEM2 screen.
2. Using the F1 key (BUZZER) or the ▲ ▼ keys, move the cursor to BUZZER VOL. To hear the preset sound, press the F1 key (BUZZER).
3. Using the rotary knob, adjust the buzzer volume.

Setting the contrast (CONTRAST)

The LCD screen contrast level can be set to 1 through 10 (at a resolution of 1).

1. To display the CONTRAST, press the SHIFT + ◀ ▶ keys to display the SYSTEM2 screen.

2. Using the F2 key (CONTRAST) or the ▲ ▼ keys, move the cursor to CONTRAST.

3. Using the rotary knob, adjust the contrast level.

The contrast level can be set using the SHIFT + ▲ ▼ keys, regardless of the screen displayed.

3.10.3 SYSTEM3

Setting the STATUS SIGNAL OUTPUT

Make settings to specify the timing of the output of a DC voltage of 24 V from the STATUS OUT connector on the rear panel.

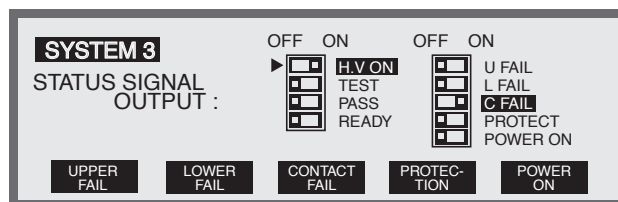
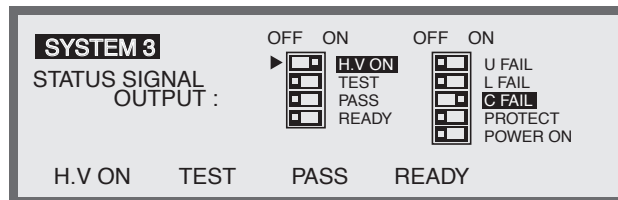

To make settings for the STATUS SIGNAL OUTPUT terminal, use the function keys or the rotary knob.

Each time a function key or the SHIFT + function keys are pressed, the item shown on the key is turned on/off.

The ▶ mark appears to the left of the selected item. Using the rotary knob, the items shown with the ▶ mark on the left can be set.

Turn the rotary knob clockwise : ON

Turn the rotary knob counterclockwise : OFF

Items set to ON are highlighted.

H.V ON

When H.V ON is set to ON, DC 24 V is output during the test, while a voltage remains between the output terminals, or during automatic testing.

TEST

When TEST is set to ON, DC 24 V is output during the test after the test voltage reaches the preset value. That is, no voltage is output during the RISE time or FALL time.

PASS

When PASS is set to ON, DC 24 V is output during a PASS judgement.

READY

When READY is set to ON, DC 24 V is output while READY is displayed on the LCD.

U FAIL

When U FAIL is set to ON, DC 24 V is output while FAIL is output in an upper judgement.

L FAIL

When L FAIL is set to ON, DC 24 V is output while FAIL is output in a lower judgement.

C FAIL

When C FAIL is set to ON, DC 24 V is output while FAIL is output in a contact check.

PROTECT

When PROTECT is set to ON, DC 24 V is output while the tester is in the PROTECTION status. However, DC 24 V is not output if the tester is in the PROTECTION status due to errors in DC 24 V of STATUS OUT or DC 24 V of SIGNAL I/O.

POWER ON

When POWER ON is set to ON, DC 24 V is output while the POWER switch is on.

3.10.4 SYSTEM4

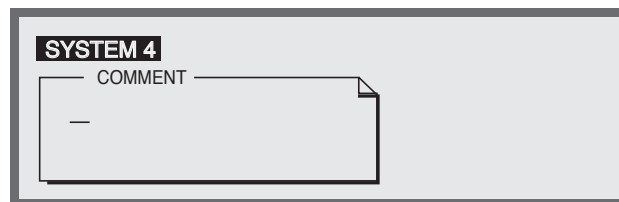

Inputting a comment (COMMENT)

A comment can be added using up to 3 lines with 20 characters per line (ASCII 20H to 7EH, Appendix 2).

1. Display the SYSTEM4 screen.
2. Using the ▲ ▼ ◀ ▶ keys, move the cursor to where the comment is to be input.
3. Using the rotary knob, select characters.

3.11 Interface Settings

To display the interface setting screen (INTERFACE), press the SHIFT + SYSTEM/I/F keys. The SYSTEM/I/F key lights up.

NOTE

- When interfaces have been changed, turn the power off and on again to confirm the new settings.

The interface setting screen permits the following settings to be made:

1. GPIB address
2. Baud rate of the RS-232C interface
3. Data length of the RS-232C interface
4. Parity of the RS-232C interface
5. Stop bit of the RS-232C interface

INTERFACE				
GPIB ADDRESS : _3				
SPEED : 19200		PARITY : NONE		
DATA : 8bit		STOP : 2bit		
GPIB	SPEED	DATA	PARITY	STOP
F1	F2	F3	F4	F5

Setting the GPIB address

Set the GPIB address to 0 through 30.

1. Using the F1 key (GPIB) or the ▲ ▼ ◀ ▶ keys, move the cursor to GPIB ADDRESS.
2. Using the rotary knob, set the GPIB address.

Setting the baud rate of the RS-232C interface

For the baud rate of the RS-232C interface, select one of the following three speeds:

38400 bps
19200 bps
9600 bps

1. Using the F2 key (SPEED) or the ▲ ▼ ◀ ▶ keys, move the cursor to SPEED.
2. Using the rotary knob, select 38,400, 19,200, or 9,600.

Setting the data length of the RS-232C interface

For the data length of the RS-232C interface, select either of the following:

7 bits

8 bits

1. Using the F3 key (DATA) or the ▲ ▼ ◀ ▶ keys, move the cursor to DATA.
2. Using the rotary knob, select 7 or 8.

Setting the parity of the RS-232C interface

For the parity of the RS-232C interface, select one of the following three parities:

NONE

ODD

EVEN

1. Using the F4 key (PARITY) or the ▲ ▼ ◀ ▶ keys, move the cursor to PARITY.
2. Using the rotary knob, select NONE, ODD, or EVEN.

Setting the stop bit of the RS-232C interface

For the stop bit of the RS-232C interface, select either of the following:

1 bit

2 bits

1. Using the F5 key (STOP) or the ▲ ▼ ◀ ▶ keys, move the cursor to STOP.
2. Using the rotary knob, select 1 or 2.

3.12 Panel Memory

The tester is capable of storing up to 100 preset patterns of test conditions in its internal memory for each AC/DC withstanding voltage test and insulation resistance test.

Storable test conditions

■ AC withstanding voltage testing

- Test voltage
- Test frequency
- Lower current (LOWER) and ON/OFF of the lower judgement function
- Upper current (UPPER)
- ON/OFF of the offset function
- Test time (TEST TIME) and ON/OFF of the timer function

- Start voltage
- Voltage rise time (RISE TIME)
- Voltage fall time (FALL TIME)
- Test-voltage range
- SLOW/MID/FAST settings for the response filter
- LOW/GUARD settings for the GND
- HIGH/LOW/OPEN settings for the scan channel
- ON/OFF of the contact check function

■ DC withstanding voltage testing

- Test voltage
- Lower current (LOWER) and ON/OFF of the lower judgement function
- Upper current (UPPER)
- Test time (TEST TIME) and ON/OFF of the timer function
- Start voltage
- Voltage rise time (RISE TIME)
- Judgement wait time (WAIT TIME)
- LOW/GUARD settings for the GND
- HIGH/LOW/OPEN settings for the scan channel
- ON/OFF of the contact check function

■ Insulation resistance testing

- Test voltage
- Lower resistance (LOWER) and ON/OFF of the lower judgement function
- Upper resistance (UPPER) and ON/OFF of the upper judgement function
- Test time (TEST TIME) and ON/OFF of the timer function
- Voltage rise time (RISE TIME)
- Judgement wait time (WAIT TIME)
- LOW/GUARD settings for the GND
- HIGH/LOW/OPEN settings for the scan channel
- ON/OFF of the contact check function

Example of an AC withstanding voltage test (display of panel memory)

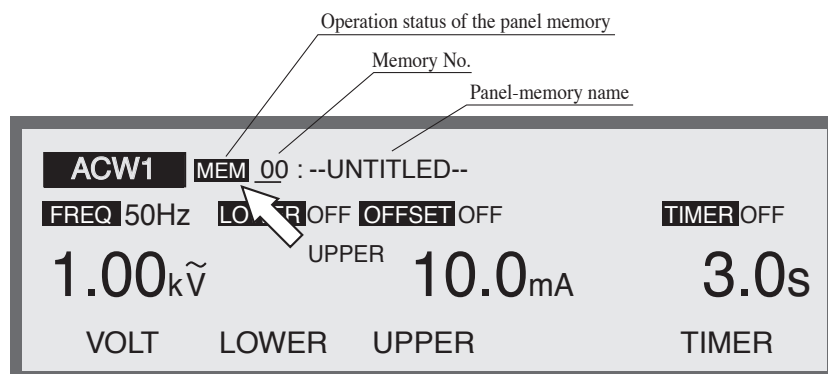

3.12.1 Storage in the panel memory

NOTE

- To store data, first specify a memory number, followed by a memory name. To return to the previous name, move the cursor to the memory number after setting the memory name.

Storing the results of an AC withstanding voltage test in panel memory (example)

1. Press the ACW key to display the AC withstanding voltage test screen (ACW1), and set the test conditions.
2. Press the SHIFT + RECALL/STORE keys to display “STO 00:--UNTITLED--” to the right of the title.
3. Using the rotary knob, set a memory number (00 to 99).
4. Using the ► key, move the cursor to “--UNTITLED--”.
5. Using the rotary knob, enter a memory name (using up to 12 characters). Use ASCII-code characters from 20H through 7EH (see the Appendix).
6. Press the ENTER key to store the test conditions under the set memory number.
Upon completion of the storage procedure, “STO” changes to “MEM.”

To cancel the storage operation, move the cursor to any location on the display before pressing the ENTER key.

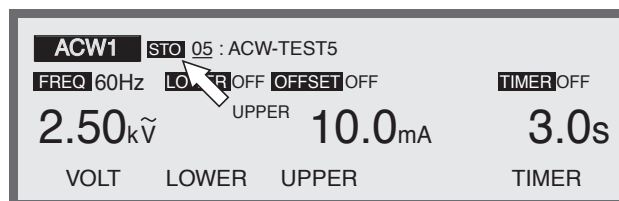

3.12.2 Recalling panel memory

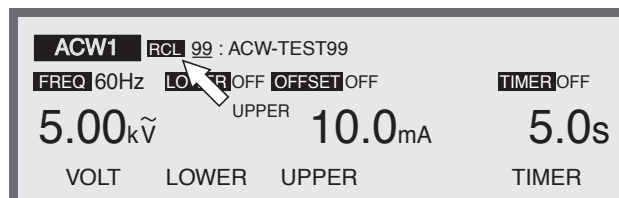

1. Press the RECALL key to display “RCL Memory No.: Memory Name” to the right of the title.
2. Using the rotary knob, specify the memory number to be recalled (00 to 99).

3. Press the ENTER key to recall the test conditions under the memory number. "RCL" changes to "MEM" to the right of the title.

To cancel the recall operation, move the cursor to any location on the display before pressing the ENTER key. Once the recalled test conditions have been changed, the memory number disappears. The memory number does not reappear even if the previous test conditions are restored.

3.13 Program

By combining test conditions stored in internal memory, up to 100 programs composed of a total of 500 steps can be created.

Each program can accommodate 100 steps.

For details on memory, see "3.12 Panel Memory".

Press the AUTO key. The LED lights up and the program screen (AUTO) is displayed.

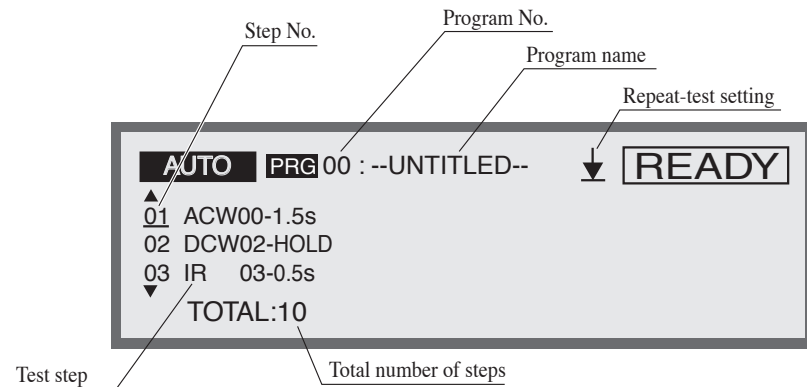

Example of a program

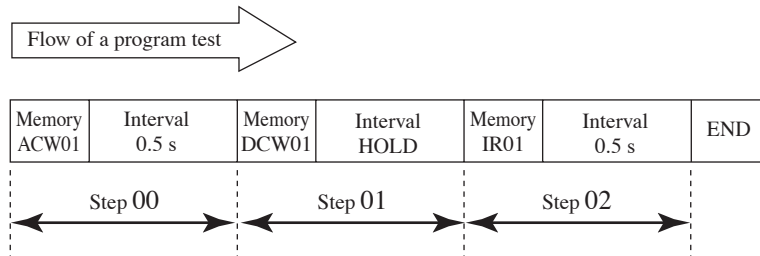

To create the above program, make the following settings:

- 00: ACW01-0.5s
- 01: DCW01-HOLD
- 02: IR01-0.5s
- END

(Explanation of the program example)

At Step 00, Memory ACW01 (AC withstanding voltage test) is conducted. Then, 0.5 second later, at Step 01, DCW01 (DC withstanding voltage test: available with the TOS9201 only) is conducted. The Step-01 interval time is set to HOLD. Thus, Step 02 does not start until the START switch is pressed. When START is pressed, IR01 (insulation resistance test) ends at Step 02 and, 0.5 seconds later, the tester enters the READY status.

When END is set to RET, the test restarts at Step 00.

3.13.1 Creating and editing a program

On the program screen (AUTO), recall the number of the program to be created or edited. Press the SHIFT + AUTO/EDIT keys. The program edit screen will then appear, with "EDIT" displayed at the top right. The program is stored as it is created or edited.

If a program is to be created or edited, the following settings must be made:

- Program name
- Memory number (step settings)
- Interval time
- Repeat-test settings

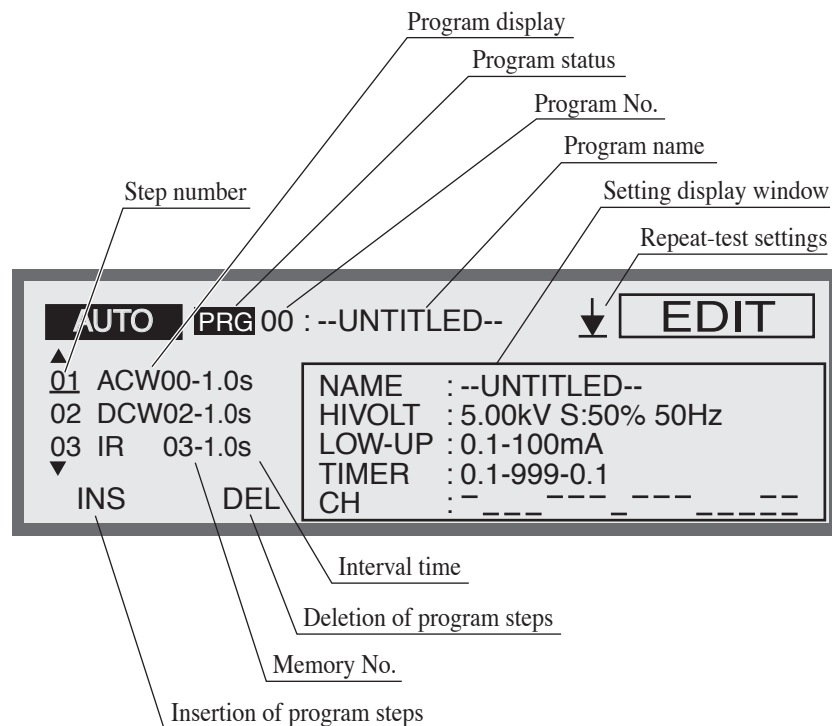

Setting the program name

Enter the name of the program to be created (using up to 12 characters).

1. Press the SHIFT + F1 keys to move the cursor to the program name.
2. Using the ◀ ▶ keys, move the cursor to the target character.
3. Using the rotary knob, select characters. Use ASCII characters from 20H (space) to 7EH (~) (see the Appendix 2).
4. Upon completion of editing, press the SHIFT + F1 keys to move the cursor to the step number.

Setting the test conditions (Memory No.) and interval time

NOTE

- If a test condition under the preset memory number is set to TIMER OFF, a program test ends once the STOP switch is pressed, preventing the next test from being performed.
-

For each step, set the memory number of the test conditions to be used and the interval between steps. The program executes the test in order of step number.

When the cursor is positioned at the step number, the screen can be scrolled using the rotary knob. The ▲ ▼ keys can be used to perform scrolling, regardless of the location of the cursor.

Upon completion of each step, "END" or "RET" is displayed.

1. To move the cursor to the step number, press the SHIFT + F1 keys.
2. Move the cursor to the step below the step to be inserted. To add a step to the previous step, move the cursor to END or RET.
3. Press the F1 key (INS). A step (ACW00-0.2s) will be inserted at the cursor.
4. Using the ▶ key, move the cursor to ACW to the right of the step number.
5. Using the rotary knob, set the target test (ACW, DCW, IR, EC). (To control the earth continuity tester TOS6200, select EC. See "Chapter 5 Controlling the TOS6200").
6. Using the ▶ key, move the cursor to the memory number.
7. Using the rotary knob, set a memory number.
8. Using the ▶ key, move the cursor to the interval time to the right of the memory number.
9. Using the rotary knob, set an interval time (from 0.2 s to 9.9 s, HOLD).
If the interval time is set to HOLD, the next step starts when the START switch is pressed with the specified step in the HOLD status.

To delete a step, move the cursor to the corresponding step number and press the F2 key (DEL).

To change the interval time or the memory number of a step, move the cursor to the target and make changes using the rotary knob.

Setting the repeat test

To make settings necessary to repeat a test, use the SHIFT + F2 keys, regardless of the location of the cursor.

Each time the SHIFT + F2 keys are pressed, END and RET alternate.

↓ END: The program ends, the tester returns to the first step and enters the READY status and.

↻ RET: The program returns to the first step and starts a new test.

3.13.2 Executing a program

NOTE

- Releasing the START switch when START MOMENTARY is on is equivalent to pressing the STOP switch. As a result, in a programmed automatic test, the test is unable to proceed to the next step if the step interval is set to HOLD.
- If the test executes a step with the timer function set to OFF, it is unable to proceed to the next step.

To run a program, display the program screen (AUTO).

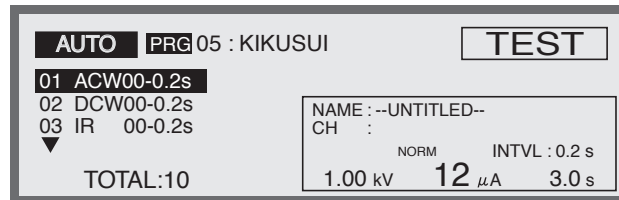

1. Press the AUTO key to display the program screen (AUTO).
2. Using the rotary knob, specify the number of the program to be recalled. The name of the selected program is displayed to the right of the program number.
To check the memory contents, press the SHIFT + F1 keys. The cursor will move to the step number. Using the rotary knob, select a step number. The test conditions for the selected step are displayed.
3. To run the program, press the START switch.

During the test, “TEST” is displayed and the TEST LED lights up on the indicator. The step being run is displayed in reverse image.

3.13.3 Suspending the program

To suspend the test while running a program, press the STOP switch.

To start the program from the beginning, press the START switch.

3.13.4 Judgement on the program

■ PASS judgement

When the interval time for each step is set to other than HOLD, the program makes a PASS judgement if a PASS judgement is made for every step (only if the programmed repeat test is set to END).

A PASS judgement is made after the interval time for the previous step has elapsed. The tester then returns to the READY status.

If the interval time for any step is set to HOLD, the test does not proceed to the next step unless the START switch is pressed.

■ FAIL judgement

Once a FAIL judgement is made while the program is being run, the test stops at that step.

Check the failed step and press the STOP switch.

If the START switch is pressed again, the program starts from the beginning.

3.13.5 Exiting the program

To exit the PROGRAM mode in order to return to the normal mode, press the ACW key (or the DCW or IR key).

The LED on the AUTO key goes off, and the test-condition setting screen appears.

3.14 Key Lock

The key lock function is used to prevent the unintentional alteration of test conditions.

To lock the panel settings, press the SHIFT + LOCAL/KEY LOCK keys.

On the panel, only the START and STOP switches are operable.

While the key lock function is on, “KEY LOCK” is displayed on the LCD.

To cancel the key lock function, press the SHIFT + LOCAL/KEY LOCK keys.

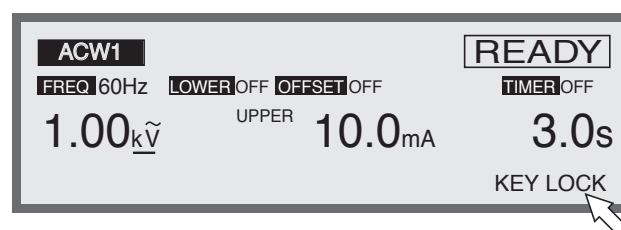

3.15 Invalid Settings

When an invalid setting is made, the messages shown below flash on the tester. Testing cannot be performed when a message is displayed. The messages below are arranged in order of priority.

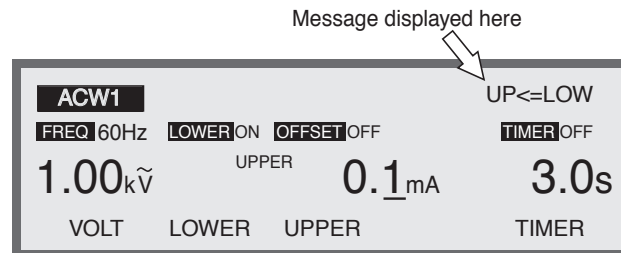

INVALID CH

“INVALID CH” appears in the scanner channel settings when a channel that is not connected to the tester is specified.

OVER WAIT

“OVER WAIT” is displayed when, with the timer on, the preset wait time exceeds the sum of the rise time and the test time.

OVER 550 VA

“OVER 550 VA” is displayed when, during settings for an AC withstanding voltage test, the test voltage multiplied by the upper current exceeds 550 VA.

OVER 55 W

“OVER 55 W” is displayed when, in settings for a DC withstanding voltage test, the test voltage multiplied by the upper current exceeds 55 VA.

OVER 1.1 mA

“OVER 1.1 mA” is displayed when, during settings for an insulation resistance test, the test voltage divided by the lower resistance exceeds 1.1 mA.

UP<=LOW

“UP<=LOW” is displayed when, with the lower or upper judgement function on, the upper value is set at or below the lower value.

3.16 Protection

The tester enters the PROTECTION status in the cases specified below, as the internal protective circuit activates.

In the PROTECTION status, the PROTECTION LED lights on the indicator, the output is cut off, and the test stops.

The following events are arranged in order of priority in protection:

■ Internal power fault

When the main power supply in the tester is overloaded, “OVER CURR” flashes on the LCD.

Press the POWER-switch again. If “OVER CURR” is still displayed, an internal circuit may be broken. Contact Kikusui distributor/agent.

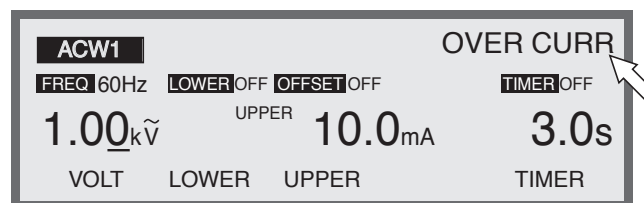

■ INTERLOCK signal

When the interlock connector is opened, the tester enters the INTERLOCK status. “INTERLOCK” flashes on the LCD.

To cancel the INTERLOCK status, short-circuit the INTERLOCK signal and press the STOP switch.

For details, see "4.3 INTERLOCK Connector".

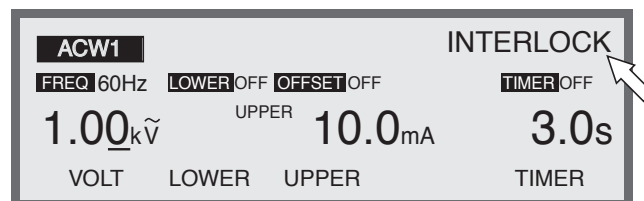

■ Insertion/extraction of the scanner connector

When a connector is inserted or extracted with the optional scanner in use, the protection function activates and “SCANNER” flashes on the LCD.

To cancel the protection function, press the STOP switch.

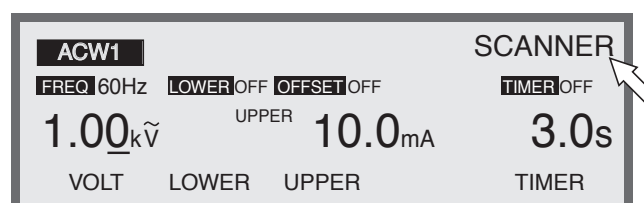

■ SIGNAL I/O signal

When there is a change in the ENABLE-signal level of pin 23 on the SIGNAL I/O connector, the protection function activates and “SIGNAL I/O” flashes on the LCD.

To cancel the protection function, press the STOP switch.

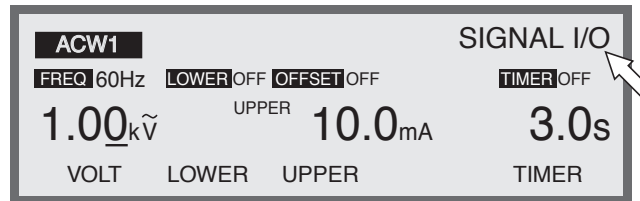

■ REMOTE

When the remote-control connector on the front panel is inserted or extracted, the protection function activates and “REMOTE” flashes on the LCD.

To cancel the protection function, press the STOP switch.



■ Monitoring of AC power

When INPUT-VOLTAGE RANGE on the rear panel differs from the actual input-voltage range, the protection function activates and the following message is displayed on the LCD.

To cancel the protection function, turn off the POWER switch, and check the AC power and the settings on the tester.

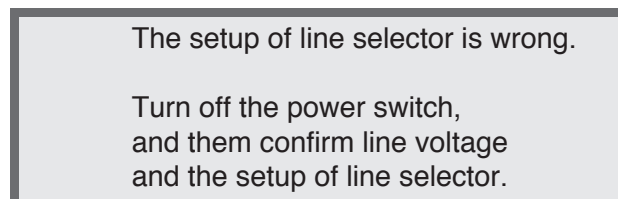

■ Output-voltage monitoring function

When the output voltage deviates from $\pm(10\%$ of the setting $+50\text{ V})$, the protection function activates. “VOLT ERROR” flashes on the LCD, and the test stops.

To cancel the protection function, press the STOP switch.

In insulation resistance testing, however, the test continues if LOWER is set to OFF. In this case, the measured voltage flashes on the LCD voltmeter to indicate the decrease in the test voltage if the output voltage deviates the monitor range.

NOTE

- In AC withstanding voltage testing, a maximum rated current of 100 mA is not achieved at a test voltage of 200 V or less. If the upper current is set to 100 mA or more at a test voltage of 200 V or less, no FAIL judgement may be made even if the output is short-circuited during the test, thus activating the output-voltage monitoring function.

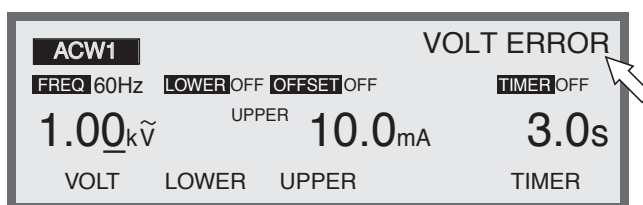

■ Output-power limiting function

This is a protection function intended to limit the output power during a test. If the output voltage multiplied by the measured current (including the offset value) exceeds 550 VA and 55 VA in AC and DC withstanding voltage tests, respectively, the protection function activates. “OVERLOAD” flashes on the LCD, and the test stops.

At an output voltage of 5.01 kV, for instance, when the measured current (including the current in the DUT and test probe) exceeds 110 mA, the output power exceeds 550 VA and the test stops due to an overload.

To cancel this function, press the STOP switch.

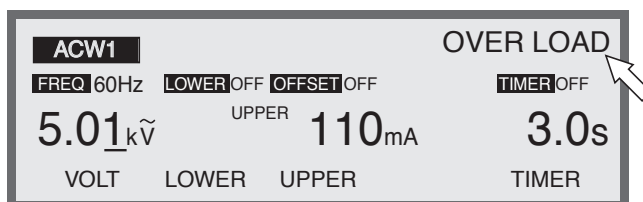

■ Overheat protection

When the internal temperature of the tester rises to an abnormal level, the protection function activates. “OVERHEAT” flashes on the LCD, and the test stops. Abnormal temperatures are caused by a reduction in the air flow of the air inlet or outlet, malfunctioning of the fan or other components, and operations at high temperatures.

Usually, the internal temperature falls to a normal level in approximately 10 minutes if there is no malfunctioning of the fan. Once the temperature returns to the normal level, press the STOP switch to cancel the protection function.

Abnormal temperatures may be caused by the malfunctioning of the fan if the protection function activates frequently.

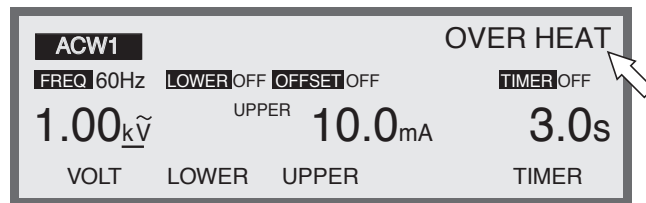

■ Time restriction by the output current

The tester is designed to release heat that is half the rated output in consideration of the tester’s size, weight, cost, and other factors. Therefore, to conduct an AC withstanding voltage test with an upper current of 50 mA, it is necessary to provide a pause longer than the output time. Note that the maximum output time is 30 minutes (at an ambient temperature of 40 °C or below). During a test, if a current of 50 mA or greater is detected for 30 minutes or more, the protection function activates. “OVERHEAT” flickers on the LCD, and the test stops. There is no time restriction when the tester is operated below 50 mA.

To cancel the protection function, turn off the POWER switch.

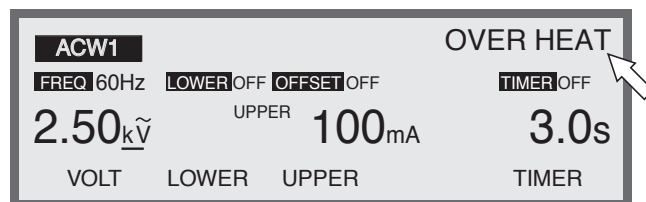

■ Abnormal 24-V output

When the DC 24-V output of the STATUS connector or SIGNAL I/O connector suffers an overload or other abnormality, the protection function activates, “24V OCP” flashes on the LCD.

To cancel the protection function, eliminate the cause of the problem and then press the STOP switch.

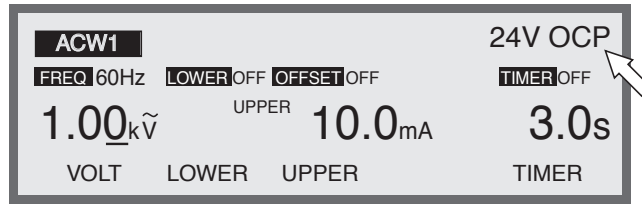

■ TOS6200 protection

When the TOS6200, while controlled by the tester, enters the PROTECTION status, the tester itself also enters the PROTECTION status. “TOS6200” flashes on the LCD.

To cancel the status, eliminate the cause of the problem with the TOS6200 and then press the STOP switch.

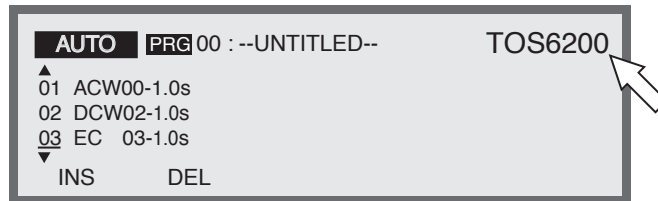

■ Communication error during TOS6200 control

When an error occurs in interface settings or communication cables while the tester is controlling the TOS6200, “COM ERR” flashes on the LCD.

To cancel the protection function, eliminate the cause of the communication error and then press the STOP switch.

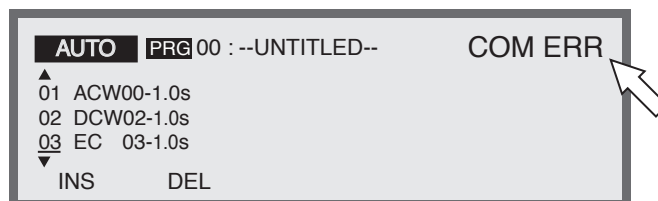

3.17 Initialization

NOTE

- When the tester is initialized, the contents of panel memory and all programs are cleared. Before initializing the tester, make sure these contents will not be needed.

To initialize the tester, press the SHIFT key + the POWER switch to start it up. Initialization will start. All contents of memory are deleted, and the tester returns to the factory settings. (Hold the SHIFT key down until “KIKUSUI ELECTRONICS CORP.” disappears.)

■ Factory settings

- **Test-Condition Settings screen (ACW)**

Test voltage (VOLTAGE)	: 0.00 kV
Frequency (FREQ)	: 50 Hz
Lower judgement (LOWER)	: OFF
Lower current (LOWER)	: 0.10 mA
Upper current (UPPER)	: 0.20 mA
Offset (OFFSET)	: OFF
Timer (TIMER)	: ON
Timer set value (TIMER)	: 0.5 s
Start voltage (START)	: 0 %
Voltage rise time (RISE TIME)	: 0.1 s
Voltage fall time (FALL TIME)	: 0.0 s
Voltage range (V RANGE)	: AUTO
Response filter (RESPONSE)	: SLOW
LOW/GUARD of the GND (GND)	: GND
Scanner channel	: ALL OPEN
CONTACT CHECK	: OFF

- **Test-Condition Settings screen (DCW)**

Test voltage (VOLTAGE)	: 0.00 kV
Lower judgement (LOWER)	: OFF
Lower current (LOWER)	: 0.10 mA
Upper current (UPPER)	: 0.20 mA
Timer (TIMER)	: ON
Timer set value (TIMER)	: 0.5 s
Start voltage (START)	: 0 %
Voltage rise time (RISE TIME)	: 0.1 s
Judgement wait time (WAIT TIME)	: 0.3 s
LOW/GUARD of the GND (GND)	: GND
Scanner channel	: ALL OPEN
CONTACT CHECK	: OFF

• **Test-Condition Settings screen (IR)**

Test voltage (VOLTAGE)	: 10 V
Lower judgement (LOWER)	: ON
Lower resistance (LOWER)	: 1.00 MΩ
Upper judgement (UPPER)	: OFF
Upper resistance (UPPER)	: 100 MΩ
Timer (TIMER)	: ON
Timer set value (TIMER)	: 0.5 s
Voltage rise time (RISE TIME)	: 0.1 s
Judgement wait time (WAIT TIME)	: 0.3 s
LOW/GUARD of the GND (GND)	: GND
Scanner channel	: ALL OPEN
CONTACT CHECK	: OFF

• **Offset screen (OFFSET)**

Offset value	
REAL (OFFSET)	: 0 μA
IMAG (OFFSET)	: 0 μA

• **System screen (SYSTEM)**

MEAS MODE	: NORM
PASS HOLD	: 0.2 s
MOMENTARY	: OFF
FAIL MODE	: OFF
DOUBLE ACTION	: OFF
BUZZER VOL	: 4
CONTRAST	: 6
STATUS-SIGNAL OUTPUT	: All OFF
COMMENT	: Clear

• **Interface screen (INTERFACE)**

GPIB ADDRESS	: 4
SPEED	: 19200
DATA	: 8 bits
PARITY	: NONE
STOP	: 2 bits



This chapter describes the procedures for use of the connectors on the front and rear panels.

-
- ⚠ WARNING**
- In remote control, the tester turns an extremely high voltage on/off using an external signal. This poses grave potential danger. Provide full safety measures to prevent the unintentional generation of a high voltage. While a high voltage is being generated, the DUT, high-voltage test leadwire, probe, and output terminals never touched. Never conduct remote control unless sufficient safety measures have been provided.
-

- NOTE**
- When the START signal of the SIGNAL I/O connector is valid, the START signal of the SIGNAL I/O has priority over that of the REMOTE terminal.
The STOP signals of the SIGNAL I/O connector and the REMOTE terminal are accepted equally.
-

REMOTE terminal on the front panel

The optional remote-control box RC01-TOS/RC02-TOS or high-voltage test probe HP01A-TOS/HP02A-TOS can be used to start and stop a test.

SIGNAL I/O connector on the rear panel

By inputting a signal to this connector, a test can be started and stopped, and the panel memory and program memory can be recalled. In addition, using the output signal from the SIGNAL I/O connector, the status of the tester can be checked.

INTERLOCK connector

Using a signal from an external safety device, the tester can be placed in the INTERLOCK status.

STATUS OUT connector

This connector is used to connect to a warning light and certain other devices. A voltage of +24 V is output under the conditions (of the tester) selected on the System screen.

4.1 REMOTE Terminal

The REMOTE terminal is the 5-pin DIN connector on the front panel.

This connector is used exclusively to connect the optional remote-control box RC01-TOS/RC02-TOS and high-voltage test probe HP01A-TOS/HP02A-TOS.

When this optional device is connected, the START switch on the front panel becomes invalid.

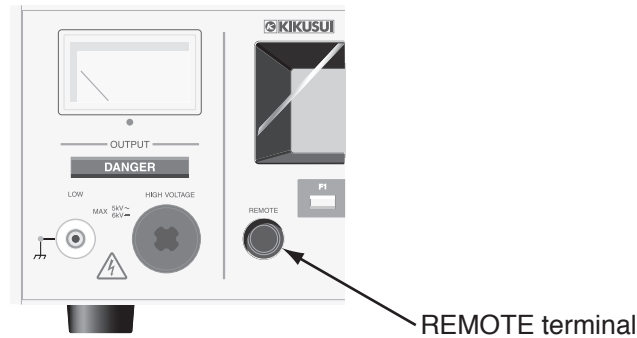

Fig.4-1 REMOTE terminal

-
- ⚠ WARNING** • Use the optional high-voltage test probe HP01A-TOS/HP02A-TOS at AC 4 kV or DC 5 kV or less.
 - ⚠ CAUTION** • Keep the signal line at least 500 mm from the high-voltage test leadwire and the DUT. Do not short-circuit the test voltage to the signal line. Otherwise, all internal circuits may be destroyed.
-

Control procedure

1. Turn off the POWER switch.
2. Using the exclusive connection cable (5-pin DIN cable), connect the optional device to the REMOTE connector on the front panel.
3. Turn on the POWER switch.
A test can be started on the optional device. In such a case, the START switch on the panel becomes invalid. To stop the test, either press the STOP switch on the panel or input the STOP signal on the optional device. For details, see the operation manual for the optional device.
4. To return to the panel for control, first turn off the POWER switch on the tester.
5. On the front panel, remove the exclusive connection cable (5-pin DIN cable) from the REMOTE connector.
6. Turn on the POWER switch.
The START switch on the panel becomes valid.

NOTE

- When the START signal of the SIGNAL I/O connector is valid, the signal has priority over the START signal of the REMOTE terminal.
The STOP signals of the SIGNAL I/O connector and the REMOTE terminal are accepted equally.
 - If the REMOTE connector is inserted/extracted with the POWER switch on, "REMOTE" flashes on the LCD. The tester enters the PROTECTION status ("PROTECTION" lights up) and cuts off the high-voltage output.
 - In making system settings, when FAIL MODE is set to ON, the FAIL or PROTECTION status cannot be cancelled even if the STOP signal is input from the REMOTE terminal. To cancel the statuses, press the STOP switch on the panel. For the system settings, see "3.10 System Settings".
-

4.2 SIGNAL I/O Connector

-
- ⚠ WARNING** • To prevent electric shock, turn off the device before connecting/disconnecting a cable.
- ⚠ CAUTION** • Keep the signal line at least 500 mm from the high-voltage test leadwire and the DUT. Do not short-circuit the test voltage to the signal line. Otherwise, all internal circuits may be destroyed.
-

The SIGNAL I/O connector is the 25-pin D-SUB connector on the rear panel.

By inputting a signal to the SIGNAL I/O connector, a test can be started/stopped and the panel memory and program memory can be recalled. In addition, the status of the tester can be checked using the output signal from the SIGNAL I/O connector.

Connector on the rear panel

XM3B-2522 D-sub 25-pin female connector (socket); manufactured by OMRON Corporation, Screw M2.6 x 0.45

Complies connector (plug)

D-sub 25-pin male (with fix screw M2.6)

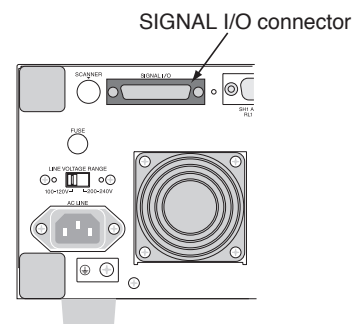

Fig.4-2 SIGNAL I/O

-
- NOTE**
- For 25-pin D-SUB connectors and cables, use a shielded type with a length of 3 m or less to prevent malfunction due to noise.
 - The internal control circuit of the tester is designed to prevent malfunction caused by noise generated by the tester or peripheral devices. However, connected devices may malfunction if unshielded cables are connected to SIGNAL I/O terminals, because such cables would virtually make a sort of “antenna” to pick up external noise. To avoid this problem, use metal connectors, shielded cables, and external circuits housed in a shielded case. Connect them to the tester’s housing (do not connect the COM line to a shield or an earth ground). These measures insulate SIGNAL I/O-related circuits from the external environment, thus reducing malfunction due to noise.
-

4.2.1 Specifications for the SIGNAL I/O connector

■ Input signal

Low active control input

High-level input voltage:
11 V to 15 V

Low-level input voltage:
0 V to 4 V

Low-level AC current:
Maximum -5 mA

Input interval:
Minimum 5 ms

■ Output signal

Open drain output

Output withstanding voltage: DC 30 V

Output saturation voltage : Approximately 0.7 V (25 °C)

Maximum output current : 400 mA (TOTAL)

■ Pin assignment

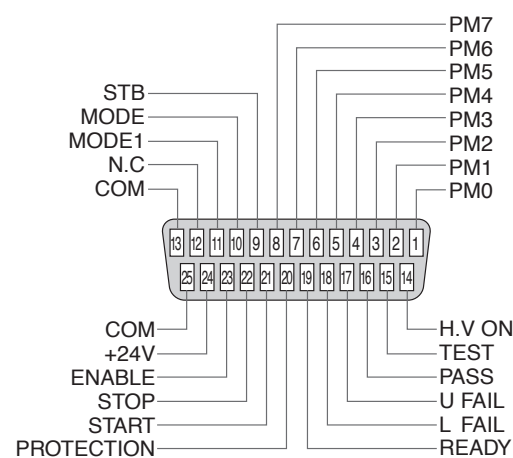

Fig.4-3 SIGNAL I/O pin assignment

No.	Signal name	I/O	Details of signal																			
1	PM0	I	LSB	LSD	2-digit BCD low active input Signal input terminal for selection between the panel memory for ACW, DCW, and IR, and the program memory for AUTO Memory recall by latching this selection signal at the rise of the strobe signal																	
2	PM1	I																				
3	PM2	I																				
4	PM3	I																				
5	PM4	I																				
6	PM5	I																				
7	PM6	I																				
8	PM7	I	MSB																			
9	STB	I	Input terminal for the strobe signal of the panel memory and program memory																			
10	MODE0	I	Selects a test mode 2-bit low active input																			
11	MODE1	I	<table border="1"> <tr> <td>MODE0</td> <td>H</td> <td>L</td> <td>H</td> <td>L</td> </tr> <tr> <td>MODE1</td> <td>H</td> <td>H</td> <td>L</td> <td>L</td> </tr> <tr> <td>Test mode</td> <td>ACW</td> <td>DCW</td> <td>IR</td> <td>AUTO</td> </tr> </table>					MODE0	H	L	H	L	MODE1	H	H	L	L	Test mode	ACW	DCW	IR	AUTO
MODE0	H	L	H	L																		
MODE1	H	H	L	L																		
Test mode	ACW	DCW	IR	AUTO																		
12	NC																					
13	COM		Circuit common (chassis potential)																			
14	H.V ON	O	ON during a test and an automatic test (AUTO) or while a voltage remains between the output terminals																			
15	TEST	O	ON during a test (except for voltage rise and voltage fall)																			
16	PASS	O	ON during the time preset in the PASS HOLD settings when a PASS judgement is made																			
17	U FAUL	O	Continuously ON in an UPPER FAIL judgement. Continuously ON in a CONTACT FAIL judgement with the scanner connected.																			
18	L FAUL	O	Continuously ON in an LOWER FAIL judgement. Continuously ON in a CONTACT FAIL judgement with the scanner connected.																			
19	READY	O	ON during the READY status																			
20	PROTECTION	O	ON when the PROTECTION function is activated																			
21	START	I	Input terminal for the START signal																			
22	STOP	I	Input terminal for the STOP signal																			
23	ENABLE	I	Input terminal for the ENABLE signal for the START signal																			
24	+24V		Output terminal for +24 V internal power, with a maximum output current of 100 mA																			
25	COM		Circuit common (chassis potential)																			

Table4-1 SIGNAL I/O assignment

NOTE

- If U FAIL and L FAIL are turned on simultaneously, CONTACT FAIL is meant.
- It is impossible to directly control the input signal using a logic IC such as HC.

■ Internal configuration

The same common line is used for the input signal circuit and the output signal circuit.

The input signal circuit is pulled up to +12 V. Therefore, opening the input terminal is equivalent to inputting a high-level signal.

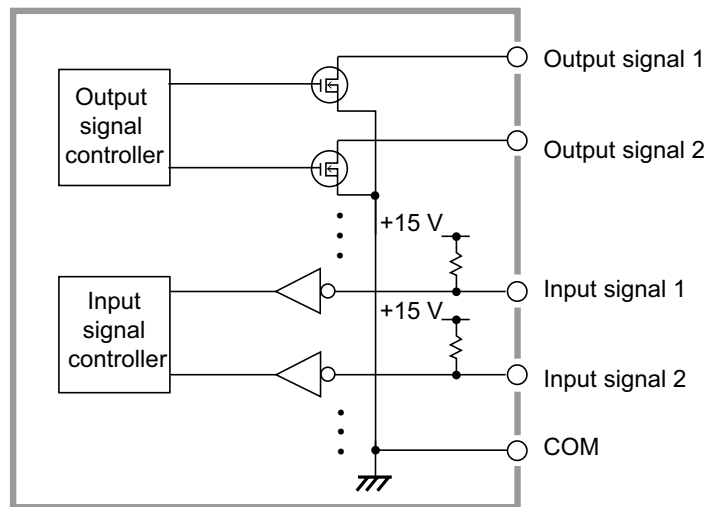

Fig.4-4 Internal configuration of the SIGNAL I/O block

4.2.2 Example

■ Input signal

Control at a make-contact

Using the make-contact of a relay or switch, set the input level to LOW.

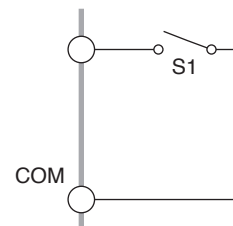

Control using a logic elements

Instead of the switch described above, use a logic element such as a transistor.

For the transistor's collector current i_c , allow at least 5 mA.

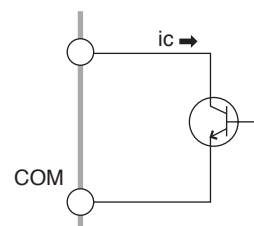

■ Output signal

NOTE

- The open collector output can lead to burning of the output device and the printed circuit board if the load is short-circuited. Use a protection fuse for output.
- To drive an inductive load such as a relay, be sure to connect a diode in parallel with the coil.

■ Output signal

Driving a relay (example)

The relay can be driven using the output signal.

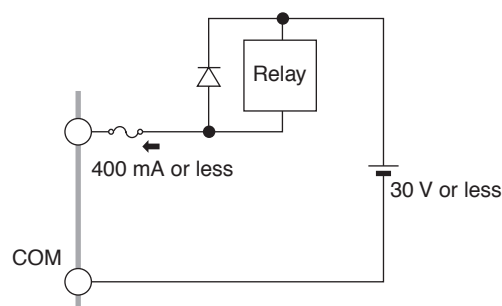

Achieving the L-level for the digital signal (example)

Using the output signal, the L-level for the digital signal can be achieved.

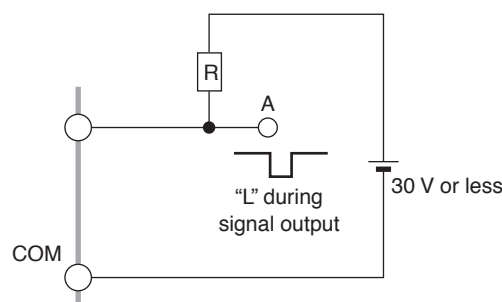

CAUTION

- Keep the signal line at least 500 mm from the high-voltage test leadwire and the DUT. Do not short-circuit the test voltage to the signal line. Otherwise, all internal circuits may be destroyed.
- Do not extract a current exceeding the maximum rated current of 100 mA from the +24 V internal power supply. Once a current exceeds the maximum rated current, the overcurrent protection function activates and “24V OCP” flashes on the LCD. The tester enters the PROTECTION status.

If the overcurrent protection function activates, turn off the POWER switch to prevent an overcurrent.

If an overcurrent flows continually for hours, the internal circuit may malfunction.

NOTE

- The internal control circuit of the tester is designed to prevent malfunction caused by noise generated by the tester or peripheral devices. However, connected devices may malfunction, if unshielded cables are connected to SIGNAL I/O terminals, because cables would virtually make a sort of “antenna” to pick up external noise. To avoid this problem, use metal connectors, shielded cables, and

external circuits housed in a shielded case. Connect them to the tester's housing (do not connect the COM line to a shield or an earth ground). These measures insulate SIGNAL I/O-related circuits from the external environment, thus reducing malfunction due to noise.

4.2.3 Starting a test

To start a test by using the SIGNAL I/O connector, set the ENABLE signal to a low level first. After a lapse of 10 ms or more from the READY signal has turned to a low level, set the START signal to a low level for 5 ms or more. The READY signal turns to a high level after the effective START signal has been detected.

When the ENABLE signal is the low level, the START signal for the SIGNAL I/O connector is enabled. At the same time, the START input for the REMOTE terminal and the START switch on the panel are disabled.

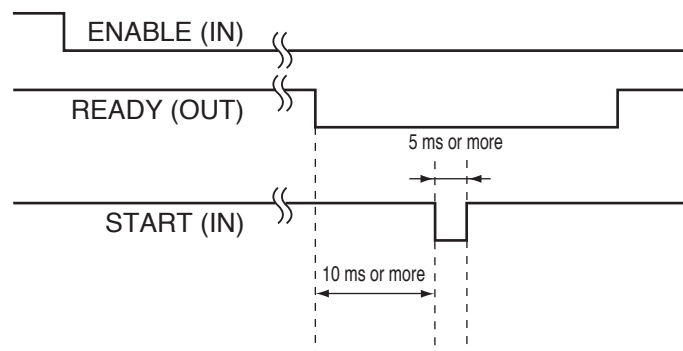

Fig.4-5 START signal

Control procedure

1. Short-circuit ENABLE of the START signal on pin 23 using pin 13 or pin 25 (COM) to shift to the low level. The START switch on the panel and the START input of REMOTE will then become invalid. A stop operation is workable with the STOP switch on the panel, or by inputting STOP from the REMOTE terminal or the STOP signal from SIGNAL I/O.
2. While the READY signal on pin 19 is ON, short-circuit the START signal on pin 21 using pin 13 or pin 25 (COM) to shift to the low level. The test will then start.
3. Short-circuit the STOP signal on pin 22 using pin 13 or pin 25 (COM) to shift to the low level. The test will then stop.
4. To cancel the remote-control function, set ENABLE of the START signal to the high level. The START switch on the panel will then become valid, while the START signal for SIGNAL I/O will become invalid.

NOTE

- When the ENABLE level of the START signal is changed, “REMOTE” flashes on the LCD. The tester enters the PROTECTION status (“PROTECTION” lights up). To cancel the PROTECTION status, use the STOP switch on the panel or the STOP signal.
 - If FAIL MODE is set to ON in the system settings, neither the FAIL status nor the PROTECTION status can be cancelled using the STOP signal from the remote control. To cancel these statuses, use the STOP switch on the panel.
For the system settings, see "3.10 System Settings".
 - The input terminal is pulled up to +12 V by resistance. Opening the input terminal is equivalent to inputting a high level.
-

4.2.4 Recalling the panel memory and programs

The MODE signal, PM signal, and STB signal are handled with the timing specified below (confirm that the READY signal is at the low level).

Fig. 4-2 shows how the MODE1 to MODE0 signals and the PM0 to PM7 signals relate to the panel memory number and the program number.

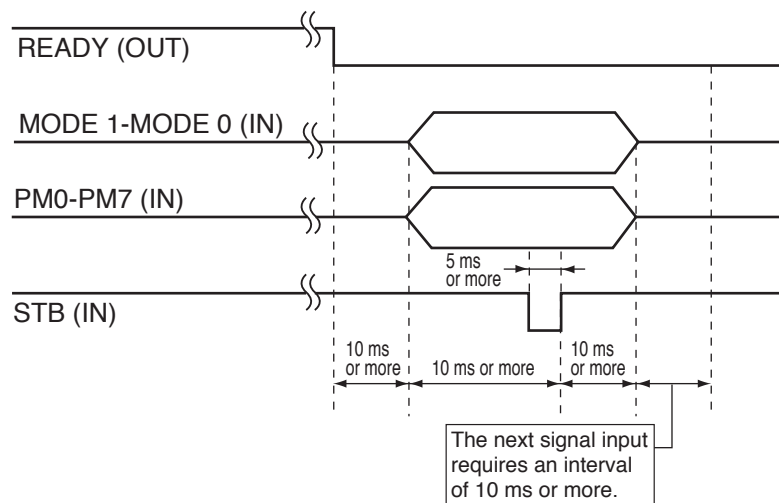

Fig.4-6 Strobe signal

NOTE

- The input terminal is pulled up to +12 V by resistance. Opening the input terminal is equivalent to inputting a high level.
-

MODE 1	MODE 0	MSD				LSD				MAIN
		PM7	PM6	PM5	PM4	PM3	PM2	PM1	PM0	
H	H	H	H	H	H	H	H	H	H	Recalls ACW panel memory 0.
		H	H	H	H	H	H	H	L	Recalls ACW panel memory 1.
		H	H	H	H	H	H	L	H	Recalls ACW panel memory 2.
		•	•	•	•	•	•	•	•	•
		•	•	•	•	•	•	•	•	•
		•	•	•	•	•	•	•	•	•
H	L	L	H	H	L	L	H	H	H	Recalls ACW panel memory 98.
		L	H	H	L	L	H	H	L	Recalls ACW panel memory 99.
		H	H	H	H	H	H	H	H	Recalls DCW panel memory 0.
		H	H	H	H	H	H	H	L	Recalls DCW panel memory 1.
		H	H	H	H	H	H	L	H	Recalls DCW panel memory 2.
		•	•	•	•	•	•	•	•	•
L	H	•	•	•	•	•	•	•	•	•
		•	•	•	•	•	•	•	•	•
		•	•	•	•	•	•	•	•	•
		L	H	H	L	L	H	H	H	Recalls IR panel memory 98.
		L	H	H	L	L	H	H	L	Recalls IR panel memory 99.
		H	H	H	H	H	H	H	H	Recalls IR panel memory 0.
L	L	H	H	H	H	H	H	H	H	Recalls AUTO program 0.
		H	H	H	H	H	H	H	L	Recalls AUTO program 1.
		H	H	H	H	H	H	L	H	Recalls AUTO program 2.
		•	•	•	•	•	•	•	•	•
		•	•	•	•	•	•	•	•	•
		•	•	•	•	•	•	•	•	•
L	H	H	L	L	H	H	H	Recalls AUTO program 98.		
L	H	H	L	L	H	H	L	Recalls AUTO program 99.		

Table4-2 PM signals and recall numbers

NOTE

- For TOS9200, which lacks a DC withstanding voltage function, the DCW items specified above are invalid.

4.3 INTERLOCK Connector

As a means of ensuring the safety of the operator, the tester is equipped with an interlock function to cut off output in coordination with external devices.

Once the interlock input terminals are opened, the interlock function activates to shift the tester to the PROTECTION status (“PROTECTION” lights up). The output is cut off to disable testing. In this status, it is impossible to start a test using the START switch (*1) or cancel the PROTECTION status using the STOP switch (*2). The interlock function restricts the tester’s output from outside to ensure the safety of the operator.

If the interlock function shifts the tester to the PROTECTION status, short-circuit the interlock input terminals to disable the INTERLOCK signal. Then, cancel the status using the STOP switch.

*1: Includes the REMOTE terminal, START signal for SIGNAL I/O, and START command for GPIB and RS-232C

*2: Includes the REMOTE terminal, STOP signal for SIGNAL I/O, and STOP command for GPIB and RS-232C



- The first time the tester is turned on following delivery, the interlock function activates and testing is disabled. An interlock jumper is provided with the product to be used for performance checks. Use this jumper only to temporarily cancel the protection function.

When installing the tester, use the interlock function as much as possible to ensure safety. When using jigs and devices in withstanding voltage and insulation resistance testing, provide a safety cover that encloses the DUT and cuts off output while the cover is open. Alternatively, to prevent electric shock, set up a safety fence around the testing area that cuts off output in coordination with door movements.

Circuit of the interlock input block

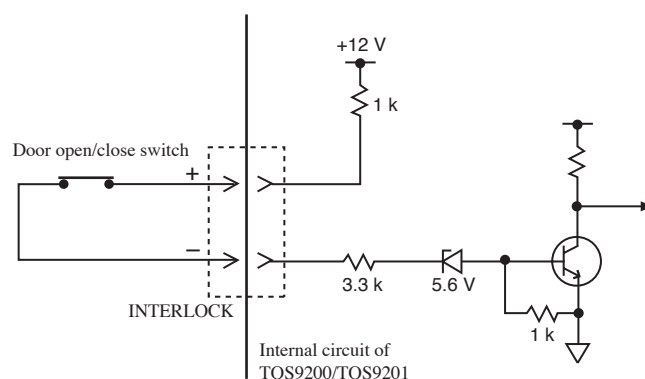

INTERLOCK-signal input requirements

Open: Terminal-to-terminal current of 0.5 mA or less

Short-circuited: Terminal-to-terminal current of 1 mA or more

Connecting the interlock jumper

1. Insert a screwdriver into A, and open B.
2. Insert the interlock jumper into B. Take care to prevent the jumper coating from becoming caught in B.
3. Lightly pull on the jumper to confirm that it is securely connected.
4. Take the same steps for the positive (+) and negative (-) terminals. Then, short-circuit (+) and (-).

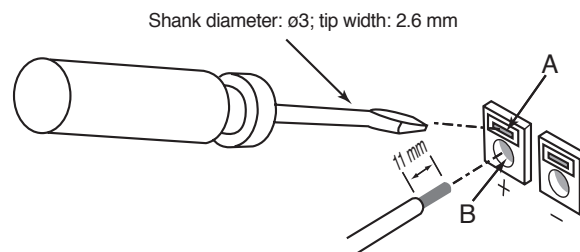

To connect a safety device, use the following cable and switch types:

Compatible cables:

- Solid wire: $\varnothing 0.65$ (AWG22)
- Stranded wire: 0.32 mm^2 (AWG22); element-wire diameter: $\varnothing 0.18$ or more
- Removed coating: 11 mm

Rated switch voltage and current:

- DC 30 V, 0.1 A or more

Circuit for reference

When the door is opened, its contacts open, thus setting the INTERLOCK signal high. This activates the interlock function.

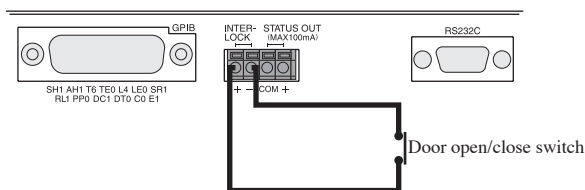

Connection to the door open/close switch

4.4 STATUS OUT Connector

The STATUS OUT connector is an output connector to be connected to the warning light.

Choose warning statuses on the System screen, from among H.V ON, TEST, PASS, READY, U FAIL, L FAIL, CONTACT FAIL, PROTECTION, and POWER ON.

If two or more statuses are chosen at a time, the logical sum of them, is outputted. For settings on the System screen, see "3.10 System Settings".

Maximum output voltage: DC 24 V; maximum output current: 100 mA

Compatible cables:

- Solid wire, $\phi 0.65$ (AWG22)
- Stranded wire, 0.32 mm^2 (AWG22); element wire diameter: $\phi 0.18$ or more

Connecting to the connector

1. Remove approximately 11 mm of coating from the tip of the signal cable.
2. Insert a screwdriver into A, and open B.
3. Insert the cable into B. Take care to prevent the coating from becoming caught in B.
4. Gently pull on the cable to confirm that it is securely connected.

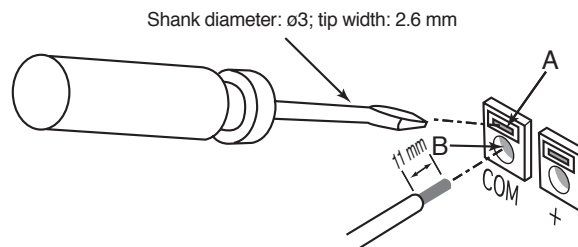

-
- CAUTION** • Do not extract a current exceeding the maximum rated current of 100 mA from the +24 V internal power supply. Once a current exceeds the maximum rated current, the overcurrent protection function activates and "24V OCP" flashes on the LCD.

The tester enters the PROTECTION status. If the overcurrent protection function activates, turn off the POWER switch to prevent an overcurrent.

If an overcurrent flows for an extended period, the internal circuit may malfunction.



This chapter describes the procedure for using the TOS9200/TOS9201 to control Kikusui's earth continuity tester TOS6200 via the RS-232C interface.

This control function is used to recall and execute the test conditions stored in the TOS6200's memory by executing the TOS9200/TOS9201 program.

For details on the RS-232C interface, see the Operation Manual for the GPIB and RS-232C Interfaces separately available.

NOTE

- The GPIB interface cannot be used to control the TOS6200 with the TOS9200/TOS9201.

During control of the TOS6200, the TOS9200/TOS9201 cannot be controlled using the GPIB interface.

5.1 Pre-Control Preparation

5.1.1 Connection and startup procedure

1. Turn off the POWER switch on the TOS9200/TOS9201 and the TOS6200.
2. Using an RS-232C cable, connect the RS-232C connectors on the rear panel of the TOS9200/TOS9201 and the TOS6200 (use a cross cable of the 9-pin D-SUB female-female AT type as the RS-232C cable).
3. Turn on the POWER switch on the TOS9200/TOS9201 and the TOS6200.

5.1.2 Settings on the TOS6200

Interface settings

On the TOS6200, press the SHIFT + SYSTEM /I/F keys. The LED on the SYSTEM /I/F key will then light up, and the Interface Settings screen (INTERFACE) will appear.

On this screen, make the settings specified below.

SPEED (baud rate)	: 19200 bps
DATA (data length)	: 8 bits
PARITY	: NONE
STOP (stop bit)	: 2 bits

Upon completion of the above settings, turn the POWER switch off and then on again.

For details on the setting procedure, see the Operation Manual for the TOS6200.

Setting the PASS hold time

On the TOS6200, press the SYSTEM key. The LED lights up on the SYSTEM key, and the System Settings screen (SYSTEM 1) appears.

The PASS hold time must be set to HOLD so that the TOS9200/TOS9201 can catch PASS signals from the TOS6200 without failure.

When the TOS9200/TOS9201 recognizes the PASS signal from the TOS6200, the tester enters the INTERVAL mode, regardless of the pass hold time settings.

For details on the setting procedure, see the Operation Manual for the TOS6200.

Setting test conditions

It is necessary to preset test conditions for the TOS6200 in panel memory.

In the TOS6200, memories 1 through 18 contain factory settings that conform to the relevant safety standards. To add new test conditions, use memories 19 through 99.

5.1.3 Settings on the TOS9200

Interface settings

On the TOS9200/9201, press the SHIFT + SYSTEM /I/F keys. The LED then lights up on the SYSTEM /I/F key, and the Interface Settings screen (INTERFACE) appears.

On this screen, make the settings specified below.

SPEED (baud rate)	: 19200 bps
DATA (data length)	: 8 bits
PARITY	: NONE
STOP (stop bit)	: 2 bits

Upon completion of the above settings, turn the POWER switch off and then on again.

For details on the setting procedure, see "3.11 Interface Settings".

Setting LOW/GUARD for the GND

To conduct an earth continuity test together with other tests, set GND to LOW on the ACW2, DCW2, and IR2 screens.

If GND is set to GUARD, the internal resistor of the TOS6200 is connected in parallel with the tester's ammeter, leading to measurement errors in the ammeter. To use the TOS6200, do not connect the TOS6200's HIGH or LOW terminal to the tester's terminal. Otherwise, set GND to LOW.

Making settings for a test program

On the TOS9200/TOS9201's Program Settings screen (AUTO), set the TOS6200's memory number for the step in which an earth continuity test is to be conducted.

For details on program settings, see "3.13 Program"

Setting procedure

1. Press the AUTO key to display the Program screen (AUTO).
2. Using the rotary knob, select the number of the program to be created or edited.
3. With the target number selected, press the SHIFT + AUTO/EDIT keys to display the Program Edit screen ("EDIT" appears at the top right of the screen).

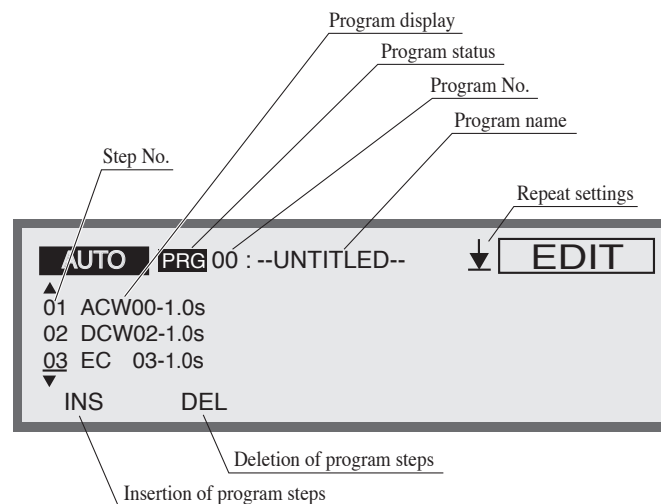

4. To enter or change program names, press the SHIFT + F1 keys to move the cursor to the program name.
Using the ◀ ▶ keys, move the cursor to the target character.
Using the rotary knob, select a character.
Use characters from 20H to 7EH of the ASCII code (see Appendix 2).
If program names are not to be changed, move on to Step 5.
5. If the cursor is at the program name, press the SHIFT + F1 keys to move the cursor to the program step.
6. Using the rotary knob or the ▼ ▲ keys, select the step number for the earth continuity test.
Position the cursor at the step to be inserted.
Press the F1 key (INS) to insert a step (ACW00-0.2s) at the cursor position.
7. Using the ▶ key, move the cursor to "ACW" to the right of the step number.
8. Using the rotary knob, select EC.
9. Using the ▶ key, move the cursor to the memory number.

10. Using the rotary knob, set the TOS6200's memory number to be used.
11. Using the ► key, move the cursor to the interval time to the right of the memory number.
12. Using the rotary knob, set the interval time (0.2 s to 9.9 s, HOLD). With the interval time set to HOLD, when the START switch is pressed, the next step starts if the specified step is in the HOLD status.
13. In accordance with the above procedure, make settings for an earth continuity test in the program step. Upon completion of settings, press the AUTO key to return to the Program screen. The Program screen displays the total number of steps thus set. The tester enters the READY status.

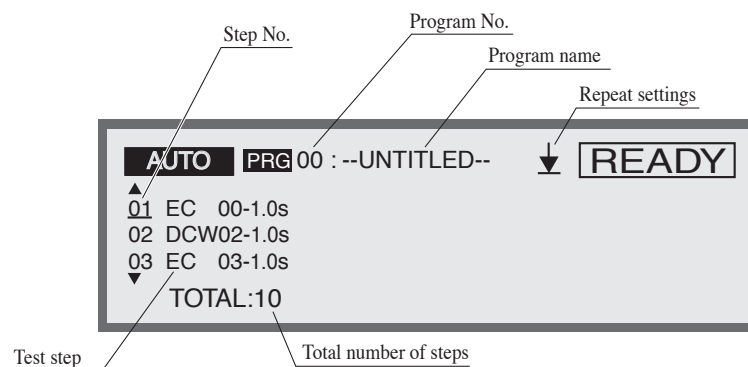

5.2 Starting a Test

Screen settings

■ TOS6200

On the TOS6200, display the Test Condition Settings screen (MAIN).

The TOS9200/TOS9201 forcibly shifts the TOS6200 to the Test Condition Settings screen (MAIN).

■ TOS9200/9201

On the TOS9200/TOS9201, display the Program screen (AUTO).

(To display the Program screen (AUTO), press the AUTO key.)

Checking the TOS6200 status

Confirm that the TOS6200 is in the READY status. In the READY status, the TOS6200 displays "READY" at the top right of the screen.

Unless the TOS6200 is in the READY status, the TOS9200/9201 is unable to control the TOS6200.

Key-locking the TOS6200

If the LOCAL key is pressed on the TOS6200 while it is running a program, the tester enters the LOCAL mode and the test is suspended.

To prevent such an occurrence, it is recommended that the tester be key-locked. To lock the panel settings, press the SHIFT + LOCAL/KEY LOCK keys.

On the panel, only the START switch and the STOP switch are valid. During key-lock, "KEY LOCK" appears on the LCD.

To cancel the key-lock function, press the SHIFT + LOCAL/KEY LOCK keys.

Starting/suspending a test

To start a test, use the START switch on the TOS9200/9201.

To suspend a test, use the STOP switch on the TOS9200/9201.

If the STOP switch on the TOS9200/9201 fails to stop the TOS6200 due to a communication error between the TOS9200/9201 and the TOS6200, also press the STOP switch on the TOS6200 to suspend the test.

5.3 Test Judgement

The TOS9200/9201 reads the test results of the TOS6200 and displays a judgement on-screen.

FAIL judgement by the TOS6200

When the TOS9200/9201 or TOS6200 makes a FAIL judgement at any step of the execution of a program, the program stops at that step regardless of whether the repeat settings of the TOS9200/9201 program are made to RETURN or END, and regardless of the preset interval time.

To cancel the FAIL status of a FAIL judgement in an earth continuity test, use the STOP switch on the TOS9200/TOS9201.

PASS judgement by the TOS6200

With the interval time for each step set to any value other than HOLD, if a PASS judgement is made for all steps, a PASS judgement is made for the program as a whole. (This applies only to the repeat settings made to END.)

A PASS judgement is made after the interval time has elapsed for the last step. The tester then returns to the READY status.

If the interval time is set to HOLD in any step, it is not possible to proceed to the next step unless the START switch on the TOS9200/TOS9201 is pressed.

To suspend the test, press the STOP switch on the TOS9200/TOS9201. The tester returns to the READY status.

NOTE

- During the execution of a program, no buzzer may sound even if the TOS6200 makes a PASS judgement. This does not indicate any abnormality.
-

Displaying a communication error

In the following cases, “COM ERR” flashes and the PROTECTION LED lights up to indicate a communication error:

- The POWER switch on the TOS6200 is turned off.
- The interface settings for the TOS6200 are not made as instructed in "5.1.2 Settings on the TOS6200"
- The RS-232C cable is disconnected or broken.
- At the start of a test, the TOS6200 is not in the READY status.

To cancel a communication error, press the STOP switch. Eliminate the cause of the communication error, and restart the test.

PROTECTION

During the execution of the TOS9200/9201 program, if the PROTECTION function activates on the TOS6200, “TOS6200” flashes at the top right of the screen on the TOS9200/TOS9201, and the PROTECTION LED lights up.

To cancel the PROTECTION function on both the TOS9200/9201 and the TOS6200, press the STOP switch on the TOS9200/TOS9201.

A test using the TOS6200 may not start, depending on the cause of PROTECTION. To restart the test, eliminate the cause of PROTECTION and confirm that the tester is in the READY status.

5.4 Canceling the TOS6200 Control Mode

The TOS9200/9201 is ready to control the TOS6200 via the RS-232C interface, so the POWER switch must first be turned off. To cancel the control mode, take the following steps:

1. On the TOS9200/9201 and the TOS6200, turn off the POWER switch.
2. On the rear panel of the TOS9200/9201 and the TOS6200, disconnect the RS-232C cable from the RS-232C connector.

To use either the TOS9200/9201 or the TOS6200 alone, turn on the POWER switch.

This chapter describes the names and functions of components such as switches, displays, and connectors on the front and rear panels.

6.1 Front Panel

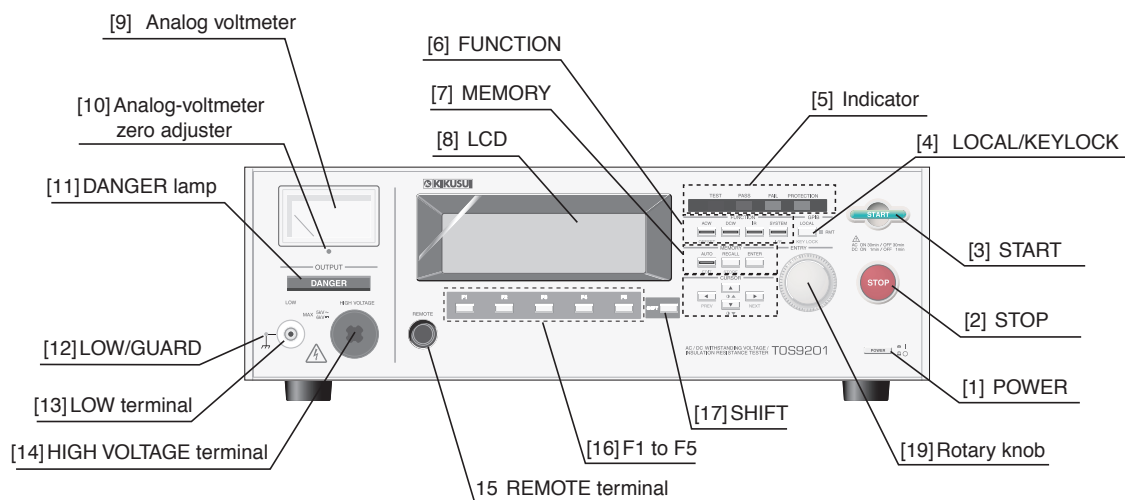

Fig.6-1 Front panel

[1] POWER

Used to turn the power on/off. When the power is turned ON (I), the tester starts under the same test conditions as when the power was turned off (O) at the end of the preceding test. To start using the factory settings, press the SHIFT key + the POWER switch to initialize the settings. For details, see "3.17 Initialization".

NOTE

- With initialization, all contents of the panel memory and stored programs are cleared. Before starting initialization, confirm that no necessary data remains in the memory.

[2] STOP

Used to suspend a test.

Also used to cancel the PASS, FAIL, and PROTECTION statuses.

After this switch is pressed, the tester enters the READY status.

[3] START

Used to start a test.

The test starts when this switch is pressed while “READY” is displayed on the LCD.

Once the test starts, the LCD displays “TEST” and the TEST LED flashes on the indicator during a voltage rise.

When the tester reaches the test voltage, the TEST LED remains lit.

[4] LOCAL/KEYLOCK

Used to return to the LOCAL mode during remote control with the GPIB or RS-232C interface. In remote control, the LED lights up to the right of the key.

To activate the key-lock function during local control, press this key together with the SHIFT key. In the key-lock mode, the LCD displays “KEYLOCK.”

[5] Indicator

- TEST
LED indicating that a test is under way.
The LED flashes during contact checks, voltage rise, and voltage fall. It lights up while the test voltage is being output.
- PASS
LED indicating the test results.
This LED lights up when a PASS judgement is made.
No PASS judgement is made when the timer function is off.
- FAIL
LED indicating the test results.
This LED lights up when a FAIL judgement is made.
- PROTECTION
LED indicating that the protection function has been activated. The activated protection function is shown at the top right of the LCD. For the protection function, see "3.16 Protection".

[6] FUNCTION

Used to select the test-mode settings, system settings, or interface settings.

- ACW/OFFSET
When this key is pressed, the LED lights up. The LCD displays the AC withstanding voltage testing screen (ACW).
To display the offset screen (OFFSET), press this key together with the SHIFT key.
- DCW (TOS9201 only)
When this key is pressed, the LED lights up. The LCD displays the DC withstanding voltage testing screen (DCW).

-
- IR
When this LED is pressed, the LED lights up. The LCD displays the insulation resistance testing screen (IR).
 - SYSTEM /I/F
When this key is pressed, the LED lights up. The LCD displays the system settings screen (SYSTEM).
To display the interface settings screen (INTERFACE), press this key together with the SHIFT key.

[7] MEMORY

- AUTO/EDIT
When this key is pressed, the LED lights up. The LCD displays the program execution screen (AUTO READY).
To display the program edit screen (AUTO EDIT), press this key together with the SHIFT key.
- RECALL/STORE
Used to recall the panel memory.
To change the memory number, first press the rotary knob, then press the ENTER key next to the rotary knob to recall the contents.
To store data in memory, press this key together with the SHIFT key.

[8] LCD

Displays settings and measurements.

[9] Analog voltmeter

Voltmeter used to display the output voltage. Directly reads the voltage between the HIGH VOLTAGE terminal and the LOW terminal.

⚠ WARNING • While the pointer of the analog voltmeter is moving, never touch the HIGH VOLTAGE terminal, test leadwire, or DUT.

⚠ CAUTION • This voltmeter cannot be used as an independent voltmeter. It may malfunction if a voltage is applied to the output terminal from outside.

[10] Analog-voltmeter zero adjuster

Adjuster used to adjust the analog voltmeter to the zero point.

⚠ CAUTION • Prior to zero adjustment, be sure to turn off the POWER switch.

[11] DANGER lamp

Red lamp indicating that a high voltage is being output.

This lamp lights up during testing and automatic testing, or while an output voltage remains in the output terminal.

-
- ⚠ WARNING** • While this lamp is lit, never touch the HIGH VOLTAGE terminal, test lead-wire, or DUT.
-

[12] LOW/GUARD

Lights when the LOW/GUARD for the GND is set to LOW for each test.

-
- ⚠ WARNING** • When this lamp is off, check the grounding of the DUT, jigs and peripheral devices. Read the relevant sections of "Chapter 3 Basic Operations", and strictly follow the instructions given.
-

[13] LOW terminal

Low-voltage terminal for outputting the test voltage.

[14] HIGH VOLTAGE terminal

High-voltage terminal for outputting the test voltage. The test voltage is output between this terminal and the LOW terminal.

-
- ⚠ WARNING** • During a test, never touch the HIGH VOLTAGE terminal.

- ⚠ CAUTION** • Internal circuit may malfunction if a voltage is applied to it from outside.
-

[15] REMOTE terminal

Terminal used to connect the optional remote-control box or the exclusive probe.

[16] F1 to F5

Functions corresponding to the F1 to F5 keys on the LCD.

[17] SHIFT

Used to switch the function menus and expand key functions.

When the POWER switch is turned on while this key is pressed, the tester settings are initialized (returns to the default settings). For details, see "3.17 Initialization".

NOTE

- With initialization, all contents of panel memory and stored programs are cleared. Before starting initialization, confirm that no necessary data remains in the memory.
-

[18] CURSOR

Used to move the cursor to set test conditions.

When pressed together with the SHIFT key, it enables screen contrast adjustment and the switching of setting screens.

[19] Rotary knob

READY status : Used to set test conditions on the LCD

Test in Progress : Used to change the test voltage

6.2 Rear Panel

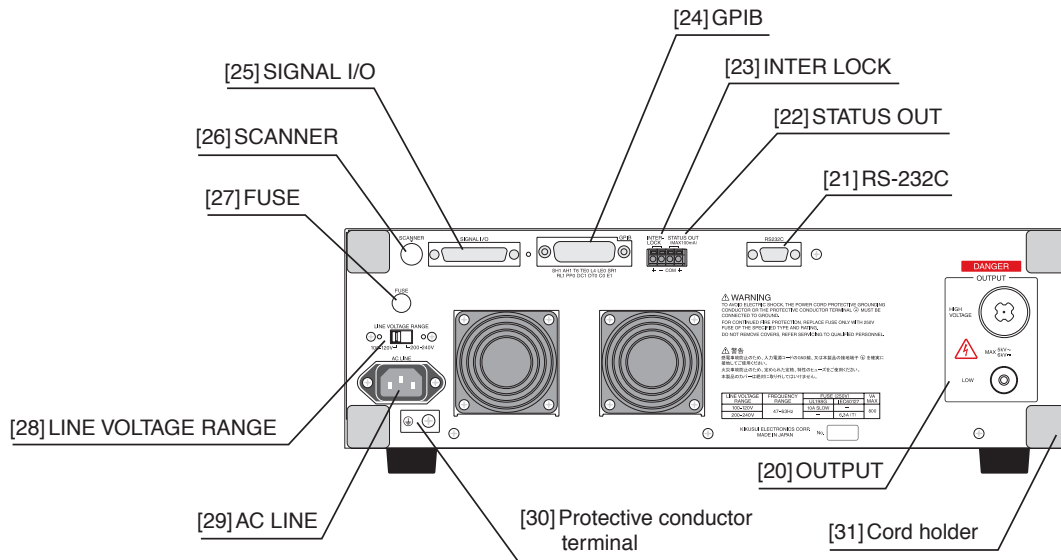

Fig.6-2 Rear panel

[20] OUTPUT

- **LOW terminal**
 Low-voltage terminal for outputting the test voltage.
 This terminal is connected to the LOW terminal on the front panel.
- **HIGH VOLTAGE terminal**
 High-voltage terminal for outputting the test voltage.
 This terminal is connected to the HIGH VOLTAGE terminal on the front panel.

⚠ WARNING • During a test, never touch the HIGH VOLTAGE terminal.

⚠ CAUTION • Internal circuit may malfunction if a voltage is applied to it from outside.

[21] RS-232C

Connector used to connect an RS-232C cable in order to remotely control the tester via a PC using the RS-232C interface.

[22] STATUS OUT

Connector for connecting a warning light.

Maximum output voltage of DC 24 V and maximum output current of 100 mA.

[23] INTERLOCK

If the line between these terminals is opened, the tester enters the PROTECTION status and disables the execution of a test. "INTER LOCK" flashes on the LCD.

[24] GPIB

Connector used to connect a GPIB cable in order to remotely control the tester via a PC using the GPIB interface.

[25] SIGNAL I/O

25-pin D-SUB connector.

Used to start and end a test by remote control, and to check the status of the tester using a signal.

For details, see "4.2 SIGNAL I/O Connector".

[26] SCANNER

Connector used to connect the optional high-voltage scanner.

[27] FUSE

Fuse holder. Contains a fuse for AC input.

⚠ WARNING • Improper handling of the fuse holder may lead to electric shock. Be sure to follow the instructions given in "1.4 Checking the Line voltage and Fuse".

[28] LINE VOLTAGE RANGE

Switch for selecting an input-voltage range.

⚠ WARNING • Before turning on the POWER switch, be sure to confirm that the voltage to be used is consistent with the voltage range selected using the LINE VOLTAGE RANGE switch. For details, see "1.4 Checking the Line voltage and Fuse".

[29] AC LINE

Power-cord connector used to supply power to the tester. Use the power cord provided with the product.

⚠ WARNING • Improper handling of this connector may lead to electric shock. Be sure to follow the instructions given in "1.5 Connecting the AC Power Cord".

[30] Protective conductor terminal

Terminal used to ground the tester.

-
- ⚠ WARNING** • Be sure to ground the tester. For details, see " • This product is an IEC Safety Class I equipment (equipment with a protective conductor terminal). To prevent electric shock, be sure to ground (earth) the unit."
-

[31] Cord holder

Holder for the power cord.

-
- ⚠ CAUTION** • Do not place the tester on sides other than the bottom surface. Leaving the cord holder beneath the tester makes it extremely unstable, and is extremely dangerous.
-

This chapter describes the maintenance, inspection, and calibration of the tester. Regular maintenance and inspection are necessary to maintain the initial performance of the product.

7.1 Cleaning

To clean the surface of the tester, including the panel, wipe it with a soft cloth moistened with water-diluted neutral detergent.

-
- ⚠ WARNING** • Before starting cleaning, be sure to turn off the POWER switch and unplug the power cord.
 - ⚠ CAUTION** • Do not use volatile materials such as thinner and benzene. These materials may change surface colors, erase prints, or blur the display.
-

7.2 Inspection

-
- ⚠ WARNING** • Tearing and breakage of the cable coating may lead to electric shock and fire. In such a case, immediately discontinue use of the tester.
-

To purchase accessories, contact Kikusui distributor/agent.

■ AC Power cord

Check for tears in the cable coating, looseness and fracture of the plug, and breakage of the cable.

■ High-voltage test leadwire

Check the cable coating for tears, fissures, and breakage.

7.3 Maintenance

- ⚠ WARNING** • To replace components, the tester cover must be opened, but only by our service representative. Contact your Kikusui agent/distributor if it is necessary to perform replacement work.
-

■ High-voltage relay

The high-voltage relays inside the tester are consumable. Although service life depends on the usage environment, we recommend that the high-voltage relays be replaced every one million tests. We also recommend regular internal inspections and cleaning at the same intervals.

■ Cooling fan

The service life of the cooling fan is approximately 60,000 hours.

The revolutions per minute of the cooling fan are controlled based on the internal temperature, and its service life depends partly on the conditions under which it is used. Replace the cooling fan after approximately 60,000 hours. In addition, conduct internal inspection and cleaning of the tester at the same time.

■ Backup battery

The tester uses a lithium battery for memory backup.

When the battery's power supply runs out, such data as test conditions cannot be stored in memory. Depending on the conditions under which it is used, replace the backup battery every three years. In addition, conduct internal inspection and cleaning of the tester at the same time.

7.4 Calibration

To maintain the accuracy of measuring instruments for an extended period, calibration should be performed regularly.

- ⚠ WARNING** • The tester generates voltages as high as AC 5 kV and DC 6 kV. Calibration is extremely dangerous; contact your Kikusui agent if calibration services are required.
-

7.5 Troubleshooting

Not all problems involve mechanical failures. Before requesting repair service, recheck your problem.

Find your problem in the list below, and correct it as instructed. If it still persists or if you cannot find it in the list, contact Kikusui distributor/agent

Problem	Checkpoint	Items for reference	Page
The tester does not start when the POWER is turned on.	• Is the power cord disconnected?	"1.5 Connecting the AC Power Cord"	1-7
	• Is the fuse broken?	"1.4 Checking the Line voltage and Fuse"	1-5
The LCD screen does not appear when the POWER is turned on.	• Is the contrast level too low?	"3.10 System Settings"	3-55
	• Is the ambient temperature too low?	"General Items of Specifications"	
A panel key does not work.	• Is the Key Lock function working?	"3.14 Key Lock"	3-69
	• Is the panel key remotely controlled from the REMOTE terminal or SIGNAL I/O?	"4.1 REMOTE Terminal" "4.2 SIGNAL I/O Connector"	4-2 4-4
	• Is the panel key remotely controlled from outside via the GPIB or RS-232C?	LOCAL/KEYLOCK	6-2
The START switch does not work.	• Is the STOP signal input?	"Chapter 4 Using Terminals and Connectors"	4-1
	• Is the tester in the PROTECTION, PASS, or FAIL status?	"3.16 Protection"	3-71
	• Are you currently making settings for the system and interface or editing a program?	"3.10 System Settings" "3.11 Interface Settings" "3.13 Program"	3-55 3-61 3-65
	• Are you currently storing data in or recalling it from the panel memory?		
	• Is the double-action function valid?	Turning the double-action function ON/OFF (DOUBLE ACTION)	3-58
	• Is "READY" displayed?	"3.15 Invalid Settings"	3-70
	• Is the ENABLE signal for SIGNAL I/O at the low level?	"4.2 SIGNAL I/O Connector"	4-4
The output voltage does not reach 2.6 kV.	• Is the output voltage range set to AUTO?	Setting the output-voltage ranges (V RANGE)	3-13
The output voltage does not reach the preset level.	• Is RISE TIME set to too large a value?	RISE TIME settings for each test	
The fan does not work.	• The revolutions per minute are controlled based on the internal temperature. The fan stops revolving if the temperature is too low. If "OVERHEAT" appears without the fan revolving, a fault has occurred.		
The high-voltage scanner does not work.	• Is the interface cable connected?		
The TOS6200 does not start up.	• Is a cross cable being used as the interface cable? • Are the RS-232C settings correct? If they are incorrect, correct them. Then, reset the POWER switch.	"Chapter 5 Controlling the TOS6200"	5-1



This chapter describes the electrical and mechanical specifications for the tester.

Withstanding Voltage test mode

Item		Specifications		
		TOS9200	TOS9201	
Output section				
AC	Output-voltage range		0.05 kV to 5.00 kV	
		Resolution	10 V	
		Accuracy	$\pm(1.5\%$ of setting + 20 V) [with no load]	
	Maximum rated load (*1)		500 VA (5 kV/100 mA)	
	Maximum rated current		100 mA [output voltage of 0.2 kV or more]	
	Transformer capacity		500 VA	
	Output-voltage waveform(*2)		Sine wave	
		Distortion	2% or less [with no load or pure resistive load at output voltage of 0.5 kV or more applied]	
	Frequency		50 Hz/60 Hz	
		Accuracy	$\pm 0.1\%$	
	Voltage regulation		$\pm 3\%$ or less [maximum rated load \rightarrow no load]	
	Short-circuit current		200 mA or more, 350 mA or less [at output voltage of 0.5 kV or more]	
	Type of output		PWM switching	
	DC	Output-voltage range		————— 0.05 kV to 6.00 kV DC
		Resolution	————— 10 V	
		Accuracy	————— $\pm(1.5\%$ of setting + 20 V)	
Maximum rated load (*1)		————— 50 W (5 kV/10 mA)		
Maximum rated current		————— 10 mA		
Ripple		No load at 5 kV	—————	50 Vp-p Typ.
		Maximum rated load	—————	150 Vp-p Typ.
Voltage regulation		—————	1 % or less [maximum rated load \rightarrow no load]	
Short-circuit current		—————	40 mA Typ.	
Discharge function		—————	Forced discharge at the end of test (discharge resistance: 125 k Ω)	
Start voltage		The voltage at the start of the test can be set as the start voltage.		
	Setting range	0% to 99% of the test voltage (resolution of 1%)		
Output-voltage monitoring function		If the output voltage exceeds $\pm(10\%$ of setting + 50 V), output is cut off and the protection function activates.		

Item	Specifications	
	TOS9200	TOS9201
Voltmeter		
Analog	Scale	6 kV AC/DC F.S
	Accuracy	±5% F.S
	Indicator	Mean-value responsive/root-mean-square value scale
Digital	Measurement range	0.0 kV to 6.00 kV AC/DC
	Resolution	10 V
	Accuracy	±(1.0% of reading + 30 V)
	Response	Mean-value responsive/root-mean-square value display (response time of 200 ms)
	HOLD function	The voltage measured at the end of test is held during the PASS and FAIL period.

*1 Limitation on output

The tester's withstanding voltage generator is designed to radiate half as much heat as the rated output, in consideration of the size, weight, cost, and other factors of the tester. It is therefore necessary to use the tester within the ranges specified below. Operations deviating from these ranges may heat the output section excessively, thereby activating the protective circuit. In such a case, suspend the test and wait until the temperature falls to the normal level.

Output limitation in withstanding voltage testing

Ambient temperature	Upper current		Pause	Output time
$t \leq 40^\circ\text{C}$	AC	$50 < i \leq 110 \text{ mA}$	At least as long as the output time	Maximum of 30 minutes
		$i \leq 50 \text{ mA}$	Not necessary	Continuous output possible
	DC	$5 < i \leq 11 \text{ mA}$	At least as long as the output time	Maximum of 1 minute
		$i \leq 5 \text{ mA}$	At least as long as the judgement wait time (WAIT TIME)	Continuous output possible

(Output time = voltage rise time + test time + voltage fall time)

*2 Test-voltage waveform

When an AC test voltage is applied to a capacitive load, it is possible that the voltage becomes higher even than that when in the no load state. Furthermore, waveform distortion also may occur if the capacitance of the load is voltage-dependent (such as of ceramics capacitors). When the test voltage is not higher than 1.5 kV and the capacitance is not larger than 1000 pF, such test voltage changes are only of negligible levels. As the output type of the high-voltage generator block of the tester is PWM switching, switching noise and spike noise that the test voltage includes increase when the test voltage is 500 V or less. The lower the test voltage is, the more the waveform distortion increases.

Item	Specifications											
	TOS9200		TOS9201									
Ammeter *3												
Measurement range	0.00 mA to 110 mA AC		0.00 mA to 110 mA AC /0.00 mA to 11 mA DC									
Display	i = measured current <table border="1"> <thead> <tr> <th>$i < 1$ mA</th> <th>$1 \text{ mA} \leq i < 10$ mA</th> <th>$10 \text{ mA} \leq i < 100$ mA</th> <th>$100 \text{ mA} \leq i$</th> </tr> </thead> <tbody> <tr> <td>□□□ μA</td> <td>□. □□ mA</td> <td>□□. □ mA</td> <td>□□□ mA</td> </tr> </tbody> </table>				$i < 1$ mA	$1 \text{ mA} \leq i < 10$ mA	$10 \text{ mA} \leq i < 100$ mA	$100 \text{ mA} \leq i$	□□□ μA	□. □□ mA	□□. □ mA	□□□ mA
$i < 1$ mA	$1 \text{ mA} \leq i < 10$ mA	$10 \text{ mA} \leq i < 100$ mA	$100 \text{ mA} \leq i$									
□□□ μA	□. □□ mA	□□. □ mA	□□□ mA									
Accuracy	±(3% of the reading + 20 μA) [after the offset cancel function is activated, if the scanner is mounted]											
Response	Mean-value responsive / root-mean-square value display (response time of 200 ms)											
Hold function	The measured current at the end of the test is held during the PASS period.											
Offset cancel function	The current flowing to the insulation resistor between the output cables and the stray capacity is cancelled up to 100 μA/kV (in AC withstanding voltage testing only).											
Calibration	Performs calibration using the root-mean-square value of a sine wave with a pure resistive load											
Selection of LOW/GUARD for the GND (*4)	Selection permitted for current measurement between the mode for the GND point connected to the LOW terminal, and the mode using guard.											
	LOW	Connects the GND point to the LOW terminal. Measures the current flowing to the LOW terminal (chassis) (for normal operation).										
	GUARD	Sets the GND point as guard. Measures the current flowing to the LOW terminal, but does not measure the current flowing to the chassis (for high-sensitivity, high-accuracy measurements).										

Item	Specifications																								
	TOS9200		TOS9201																						
Judgement function																									
Judgement method/action	<table border="1"> <thead> <tr> <th>Judgement</th> <th>Judgement method</th> <th>Display</th> <th>Buzzer</th> <th>SIGNAL I/O</th> </tr> </thead> <tbody> <tr> <td>UPPER FAIL</td> <td>When the tester detects a current exceeding the upper current, it cuts off the output and makes an UPPER FAIL judgement. In DC withstanding voltage testing, however, no judgement is made until the judgement wait time (WAIT TIME) has elapsed.</td> <td>The FAIL LED lights up. Displayed on the LCD</td> <td>ON</td> <td>Outputs the U FAIL signal</td> </tr> <tr> <td>LOWER FAIL</td> <td>When the tester detects a current below the lower current, it cuts off the output and makes a LOWER FAIL judgement. However, no judgement is made during the voltage rise time (RISE TIME) or voltage fall time (FALL TIME) in AC withstanding voltage testing.</td> <td>The FAIL LED lights up. Displayed on the LCD</td> <td>ON</td> <td>Outputs the L FAIL signal</td> </tr> <tr> <td>PASS</td> <td>When the preset time has elapsed without any abnormalities, the tester cuts off the output and makes a PASS judgement.</td> <td>The PASS LED lights up. Displayed on the LCD</td> <td>ON</td> <td>Outputs the PASS signal</td> </tr> </tbody> </table>					Judgement	Judgement method	Display	Buzzer	SIGNAL I/O	UPPER FAIL	When the tester detects a current exceeding the upper current, it cuts off the output and makes an UPPER FAIL judgement. In DC withstanding voltage testing, however, no judgement is made until the judgement wait time (WAIT TIME) has elapsed.	The FAIL LED lights up. Displayed on the LCD	ON	Outputs the U FAIL signal	LOWER FAIL	When the tester detects a current below the lower current, it cuts off the output and makes a LOWER FAIL judgement. However, no judgement is made during the voltage rise time (RISE TIME) or voltage fall time (FALL TIME) in AC withstanding voltage testing.	The FAIL LED lights up. Displayed on the LCD	ON	Outputs the L FAIL signal	PASS	When the preset time has elapsed without any abnormalities, the tester cuts off the output and makes a PASS judgement.	The PASS LED lights up. Displayed on the LCD	ON	Outputs the PASS signal
	Judgement	Judgement method	Display	Buzzer	SIGNAL I/O																				
	UPPER FAIL	When the tester detects a current exceeding the upper current, it cuts off the output and makes an UPPER FAIL judgement. In DC withstanding voltage testing, however, no judgement is made until the judgement wait time (WAIT TIME) has elapsed.	The FAIL LED lights up. Displayed on the LCD	ON	Outputs the U FAIL signal																				
	LOWER FAIL	When the tester detects a current below the lower current, it cuts off the output and makes a LOWER FAIL judgement. However, no judgement is made during the voltage rise time (RISE TIME) or voltage fall time (FALL TIME) in AC withstanding voltage testing.	The FAIL LED lights up. Displayed on the LCD	ON	Outputs the L FAIL signal																				
	PASS	When the preset time has elapsed without any abnormalities, the tester cuts off the output and makes a PASS judgement.	The PASS LED lights up. Displayed on the LCD	ON	Outputs the PASS signal																				
<ul style="list-style-type: none"> The PASS signal is output at the timing preset on PASS HOLD. If HOLD is set, the PASS signal is output continuously until the STOP signal is input. The UPPER FAIL signal and the LOWER FAIL signal are output continuously until the STOP signal is input. The FAIL and PASS buzzer volumes are adjustable. However, they cannot be adjusted individually, as they are set in common. 																									
Setting range for the upper current (UPPER)	0.01 mA to 110 mA AC		0.01 mA to 110 mA AC / 0.01 mA to 11 mA DC																						
Setting range for the lower current (LOWER)	0.01 mA to 110 mA AC (With the LOWER OFF function)		0.01 mA to 110 mA AC / 0.01 mA to 11 mA DC (With the LOWER OFF function)																						
Judgement accuracy (*3)	$\pm(3\% \text{ of setting} + 20 \mu\text{A})$ [After the offset cancel function is activated, if the scanner is mounted]																								
Current detection method	The absolute current values are integrated and compared with the reference value.																								
Response switching function	The current detection response for UPPER FAIL judgement can be set to FAST/MID/SLOW (for AC withstanding voltage testing only).																								
Time																									
Setting range for the voltage rise time (RISE TIME)	0.1 s to 200 s																								
Setting range for the voltage fall time (FALL TIME)	0 s to 200 s (Valid only with PASS judgement)		0 s to 200 s (Valid only with PASS judgement in AC withstanding voltage testing)																						
Setting range for the test time (TEST TIME)	0.3 s to 999 s With the TIMER OFF function																								
Accuracy	$\pm (100 \text{ ppm} + 20 \text{ ms})$																								
Setting range for the judgement wait time (WAIT TIME)	—————		0.3 s to 10 s (Only for DC withstanding voltage testing) [(RISE TIME + TEST TIME) > WAIT TIME]																						

*3

In AC withstanding voltage testing, a current flows into the stray capacity of measurement leadwire and fixtures. When the optional high-voltage scanner TOS9220/9221 is used, a current of approximately 22 $\mu\text{A}/\text{kV}$ flows into the stray capacity of each scanner. The table below shows the approximate currents flowing into such stray capacity.

When the GND is set to LOW, a current flowing into the stray capacity is added for measurement purposes to the current flowing into the DUT. In particular, for high-sensitivity, high-accuracy judgement, it is necessary to add the current flowing into the stray capacity to the lower/upper current.

When the GND is set to GUARD, the effect of the current flowing into the stray capacity is negligible. If the offset cancel function is used, the current flowing into the stray capacity can be eliminated from the measurement.

Output voltage	1 kV	2 kV	3 kV	4 kV	5 kV
Hanging a 350 mm test leadwire (Typ. value)	2 μA	4 μA	6 μA	8 μA	10 μA
Using the accessory leadwire TL01-TOS (Typ. value)	16 μA	32 μA	48 μA	64 μA	80 μA
High-voltage scanner (Typ. value, not including the test leadwire)	22 μA	44 μA	66 μA	88 μA	110 μA

*4

With the GND set to GUARD, current measurement is disabled if the part of the DUT connected to the LOW terminal is grounded, which poses extreme danger. Never ground the DUT. In ordinary operation, set the GND to LOW.

Insulation Resistance Testing Mode

Item	Specifications (TOS9200/TOS9201)										
Output section											
Output-voltage range	-25 V to -1 000 V										
	Resolution	1 V									
	Accuracy	± (1.5 % of Setting + 2 V)									
Maximum rated load	1 W (-1000 V DC/1 mA)										
Maximum rated current	1 mA										
Ripple	1 kV no-load	2 Vp-p or less									
	Maximum rated load	10 Vp-p or less									
Voltage regulation	1% or less [Maximum rated load → no load]										
Short-circuit current	12 mA or less										
Discharge function	Forced discharge at the end of test (discharge resistance: 25 kΩ)										
Output-voltage monitoring function	If the output voltage exceeds ±(10% of the setting + 50 V), output is cut off and the protection function activates.										
Voltmeter											
Analog	Scale	6 kV AC/DC F.S									
	Accuracy	±5% F.S									
	Indicator	Mean-value responsive / root-mean-square value scale									
Digital	Measurement range	0 V to -1200 V									
	Resolution	1 V									
	Accuracy	± (1 % of reading + 1 V)									
Resistance meter											
Measurement range	0.01 MΩ - 9.99 GΩ (*5) (Within the maximum rated current range of 1 mA to 50 nA)										
Display	<table border="1"> <thead> <tr> <th>R < 10.0 MΩ</th> <th>10.0MΩ ≤ R < 100.0MΩ</th> <th>100.0MΩ ≤ R < 1.00GΩ</th> <th>1.00GΩ ≤ R ≤ 9.99GΩ</th> </tr> </thead> <tbody> <tr> <td>□. □□ MΩ</td> <td>□□. □ MΩ</td> <td>□□□ MΩ</td> <td>□. □□ GΩ</td> </tr> </tbody> </table> <p style="text-align: center;">R = measured insulation resistance</p>			R < 10.0 MΩ	10.0MΩ ≤ R < 100.0MΩ	100.0MΩ ≤ R < 1.00GΩ	1.00GΩ ≤ R ≤ 9.99GΩ	□. □□ MΩ	□□. □ MΩ	□□□ MΩ	□. □□ GΩ
R < 10.0 MΩ	10.0MΩ ≤ R < 100.0MΩ	100.0MΩ ≤ R < 1.00GΩ	1.00GΩ ≤ R ≤ 9.99GΩ								
□. □□ MΩ	□□. □ MΩ	□□□ MΩ	□. □□ GΩ								
Accuracy	<table border="1"> <thead> <tr> <th>50 nA ≤ i ≤ 100 nA</th> <th>100 nA < i ≤ 200 nA</th> <th>200 nA < i ≤ 1 μA</th> <th>1 μA < i ≤ 1 mA</th> </tr> </thead> <tbody> <tr> <td>± (20 % of reading)</td> <td>± (10 % of reading)</td> <td>± (5 % of reading)</td> <td>± (2 % of reading)</td> </tr> </tbody> </table> <p>[In the humidity range of 20 % to 70 % R.H (no condensation), i = measured current with no disturbance such as swinging of the test leadwire]</p>			50 nA ≤ i ≤ 100 nA	100 nA < i ≤ 200 nA	200 nA < i ≤ 1 μA	1 μA < i ≤ 1 mA	± (20 % of reading)	± (10 % of reading)	± (5 % of reading)	± (2 % of reading)
50 nA ≤ i ≤ 100 nA	100 nA < i ≤ 200 nA	200 nA < i ≤ 1 μA	1 μA < i ≤ 1 mA								
± (20 % of reading)	± (10 % of reading)	± (5 % of reading)	± (2 % of reading)								
Hold function	The measured current at the end of the test is held during the PASS period.										
Selection of LOW/GUARD for the GND (*4)	Selection permitted for current measurement between the mode for the GND point connected to the LOW terminal, and the mode using guard.										
	LOW	Connects the GND point to the LOW terminal. Measures the current flowing to the LOW terminal (chassis) (for normal operation).									
	GUARD	Sets the GND point as guard. Measures the current flowing to the LOW terminal, but does not measure the current flowing to the chassis (for high-sensitivity, high-accuracy measurements).									

*4

When the GND is set to GUARD, current measurement is disabled if the part of the DUT connected to the LOW terminal is grounded, which poses extreme danger. Never ground the DUT. In ordinary operation, set the GND to LOW.

*5

The meter can display up to 99.9 GΩ.

Item	Specifications (TOS9200/TOS9201)				
Judgement function					
Judgement method/action	Judge- ment	Judgement method	Display	Buzzer	SIGNAL I/O
	UPPER FAIL	When the tester detects a resistance exceeding the upper resistance, it cuts off the output and makes an UPPER FAIL judgement. However, no judgement is made during a voltage rise time (RISE TIME).	The FAIL LED lights up. Displayed on the LCD	ON	Outputs the U FAIL signal
	LOWER FAIL	When the tester detects a resistance below the lower resistance, it cuts off the output and makes a LOWER FAIL judgement. However, no judgement is made until the judgement wait time (WAIT TIME) has elapsed.	The FAIL LED lights up. Displayed on the LCD	ON	Outputs the L FAIL signal
	PASS	When the preset time has elapsed without any abnormalities, the tester cuts off the output and makes a PASS judgement.	The PASS LED lights up. Displayed on the LCD	ON	Outputs the PASS signal
	<ul style="list-style-type: none"> • The PASS signal is output at the timing preset on PASS HOLD. If HOLD is set, the PASS signal is output continuously until the STOP signal is input. • The UPPER FAIL signal and the LOWER FAIL signal are output continuously until the STOP signal is input. • The FAIL and PASS buzzer volumes are adjustable. However, they cannot be adjusted individually, as they are set in common. 				
Setting range for the upper resistance (UPPER)	0.01 MΩ to 9.99 GΩ [Below the maximum rated current]				
Setting range for the lower resistance (LOWER)	0.01 MΩ to 9.99 GΩ [Below the maximum rated current]				
Judgement accuracy For both UPPER and LOWER	Judgement current	50 nA ≤ i ≤ 100 nA	100 nA < i ≤ 200 nA	200nA < i ≤ 1 μA	1 μA < i ≤ 1 mA
	UPPER, LOWER	—	—	—	± (2 % of setting + 3digit)
	0.01 MΩ ≤ R < 10.0 MΩ				
	10.0 MΩ ≤ R < 50.0 MΩ				
	50.0 MΩ ≤ R < 100 MΩ				
	100 MΩ ≤ R < 200 MΩ		± (10 % of setting + 5digit)	± (5 % of setting + 5digit)	
	200 MΩ ≤ R < 500 MΩ				
	500 MΩ ≤ R < 1.00 GΩ				
	1.00 GΩ ≤ R < 2.00 GΩ				
	2.00 GΩ ≤ R < 5.00 GΩ	± (20 % of setting + 20digit)	± (10 % of setting + 10digit)	—	
	5.00 GΩ ≤ R < 10.0 GΩ				
Judgement current = test voltage/(UPPER,LOWER)					
[In the humidity range of 20 % to 70 % R.H (no condensation), with no disturbance such as swinging of the test leadwire]					
[In LOWER judgement, at least 0.5 s is necessary for testing after the WAIT TIME has elapsed. In LOWER judgement for 200 nA or lower, a wait time of at least 1.0 s is necessary.]					

Item	Specifications (TOS9200/TOS9201)
Time	
Setting range for the voltage rise time (RISE TIME)	0.1 s to 200 s
Setting range for the test time (TEST TIME)	0.5 s to 999 s With the TIMER OFF function
Accuracy	$\pm (100 \text{ ppm} + 20 \text{ ms})$
Setting range for the judgment wait time (WAIT TIME)	0.3 s to 10 s [(RISE TIME + TEST TIME) > WAIT TIME]

Interface and Other Functions (TOS9200/TOS9201)

Item		Specifications																		
REMOTE		5-pin DIN connector on front panel Remote control of start/stop operation using an option <ul style="list-style-type: none"> Remote control box RC01-TOS, RC02-TOS High-voltage test probe HP01A-TOS, HP02A-TOS (at a test voltage of AC 4 kV/DC 5 kV or less) 																		
SIGNAL I/O		25-pin D-SUB connector on rear panel																		
No.	Signal name	I/O	Description of signals																	
1	PM0	I	LSB	LSD	2-digit BCD low active input Signal input terminal for selection between the panel memory for ACW, DCW, and IR, and the program memory for AUTO Memory recall by latching this selection signal at the rise of the strobe signal															
2	PM1	I																		
3	PM2	I																		
4	PM3	I																		
5	PM4	I		MSD																
6	PM5	I																		
7	PM6	I																		
8	PM7	I	MSB																	
9	STB	I	Input terminal for the strobe signal of the panel memory or the program memory																	
10	MODE0	I	Selection of a test mode 2-bit low active input																	
11	MODE1	I	<table border="1"> <tr> <td>MODE0</td> <td>H</td> <td>L</td> <td>H</td> <td>L</td> </tr> <tr> <td>MODE1</td> <td>H</td> <td>H</td> <td>L</td> <td>L</td> </tr> <tr> <td>Test mode</td> <td>ACW</td> <td>DCW</td> <td>IR</td> <td>AUTO</td> </tr> </table>			MODE0	H	L	H	L	MODE1	H	H	L	L	Test mode	ACW	DCW	IR	AUTO
MODE0	H	L	H	L																
MODE1	H	H	L	L																
Test mode	ACW	DCW	IR	AUTO																
12	NC																			
13	COM		Circuit common (chassis potential)																	
14	H.V ON	O	ON during a test and an automatic test (AUTO) or while a voltage remains between the output terminals																	
15	TEST	O	ON during a test (except for voltage rise and voltage fall)																	
16	PASS	O	ON during the time preset in the PASS HOLD settings when a PASS judgement is made																	
17	U FAIL	O	Continuously ON in an UPPER FAIL judgement. Continuously ON in a CONTACT FAIL judgement with the scanner connected.																	
18	L FAIL	O	Continuously ON in an LOWER FAIL judgement. Continuously ON in a CONTACT FAIL judgement with the scanner connected.																	
19	READY	O	ON during the READY status																	
20	PROTECTION	O	ON when the PROTECTION function is activated																	
21	START	I	Input terminal for the START signal																	
22	STOP	I	Input terminal for the STOP signal																	
23	ENABLE	I	Input terminal for the ENABLE signal for the START signal																	
24	+24 V		Output terminal for +24 V internal power, with a maximum output current of 100 mA																	
25	COM		Circuit common (chassis potential)																	

Item		Specifications																																											
SIGNAL I/O	Input specifications																																												
	High-level input voltage	11 V to 15 V	Low active control of all input signals The input terminal is pulled up by the resistance to +12 V. Opening the input terminal is equivalent to inputting a high-level voltage.																																										
	Low-level input voltage	0 V to 4 V																																											
	Low-level input current	Maximum of -5 mA																																											
	Input period	Minimum of 5 ms																																											
	Output specifications																																												
	Output method	Open drain output (4.5 V to 30 V DC)																																											
	Output withstanding voltage	30 V DC																																											
	Output saturation voltage	Approximately 0.7 V (25 °C)																																											
	Maximum output current	400 mA (TOTAL)																																											
STATUS OUT		Output terminal for the warning light																																											
	+ terminal (red)	Outputs +24 V during the preset period with a maximum output current of 100 mA																																											
	- terminal (black)	+24 V circuit common line																																											
INTERLOCK input		Cuts off output when the + and - terminals are opened, and enters the PROTECTION status to disable testing																																											
	+ terminal (yellow)	Interlock input + terminal	Open: When the current between terminals is 0.5 mA or less Short-circuited: When the current between terminals is 1 mA or more																																										
	- terminal (yellow)	Interlock input - terminal																																											
SCANNER		8-pin MINI DIN connector on rear panel Interface terminal for optional high-voltage scanner TOS9220/9221																																											
RS-232C		9-pin D-SUB connector on rear panel (conforming to EIA-232-D) Remote control possible for all functions other than POWER switch, KEY-LOCK, and AUTO																																											
	Baud rates	9600 bps/19200 bps/38400 bps																																											
	TOS6200 interface (only in AUTO mode)	START/STOP control, test-condition settings Reads TOS6200 measurements and measurement results																																											
GPIB		Conforms to IEEE Std.488-1978 Remote control possible for all functions other than POWER switch, KEY-LOCK, and AUTO																																											
		<table border="1"> <thead> <tr> <th>Function</th> <th>Subset</th> <th>Description</th> </tr> </thead> <tbody> <tr> <td>Source handshaking</td> <td>SH1</td> <td>All functions provided</td> </tr> <tr> <td>Acceptor handshaking</td> <td>AH1</td> <td>All functions provided</td> </tr> <tr> <td>Talker</td> <td>T6</td> <td>All functions provided except for the talk-only function</td> </tr> <tr> <td>Expansion talker</td> <td>TE0</td> <td>No function</td> </tr> <tr> <td>Listener</td> <td>L4</td> <td>All functions provided except for the listen-only function</td> </tr> <tr> <td>Expansion listener</td> <td>LE0</td> <td>No function</td> </tr> <tr> <td>Service request</td> <td>SR1</td> <td>All functions provided</td> </tr> <tr> <td>Remote local</td> <td>RL1</td> <td>All functions provided</td> </tr> <tr> <td>Parallel port</td> <td>PP0</td> <td>No function</td> </tr> <tr> <td>Device clear</td> <td>DC1</td> <td>All functions provided</td> </tr> <tr> <td>Device trigger</td> <td>DT0</td> <td>No function</td> </tr> <tr> <td>Controller</td> <td>C0</td> <td>No function</td> </tr> <tr> <td>Electrical interface</td> <td>E1</td> <td>Open collector</td> </tr> </tbody> </table>		Function	Subset	Description	Source handshaking	SH1	All functions provided	Acceptor handshaking	AH1	All functions provided	Talker	T6	All functions provided except for the talk-only function	Expansion talker	TE0	No function	Listener	L4	All functions provided except for the listen-only function	Expansion listener	LE0	No function	Service request	SR1	All functions provided	Remote local	RL1	All functions provided	Parallel port	PP0	No function	Device clear	DC1	All functions provided	Device trigger	DT0	No function	Controller	C0	No function	Electrical interface	E1	Open collector
Function	Subset	Description																																											
Source handshaking	SH1	All functions provided																																											
Acceptor handshaking	AH1	All functions provided																																											
Talker	T6	All functions provided except for the talk-only function																																											
Expansion talker	TE0	No function																																											
Listener	L4	All functions provided except for the listen-only function																																											
Expansion listener	LE0	No function																																											
Service request	SR1	All functions provided																																											
Remote local	RL1	All functions provided																																											
Parallel port	PP0	No function																																											
Device clear	DC1	All functions provided																																											
Device trigger	DT0	No function																																											
Controller	C0	No function																																											
Electrical interface	E1	Open collector																																											

Item		Specifications
Indicator		240x64-dot LCD. Displays settings, measurements and judgement results.
Testing function	ACW	Executes AC withstanding voltage test
	DCW (*6)	Executes DC withstanding voltage test
	IR	Executes insulation resistance test
	AUTO (*6)	Automatically executes AC withstanding voltage test (ACW), DC withstanding voltage test (DCW), insulation resistance test (IR), and earth continuity test (EC). The TOS6200 (Earth Continuity Tester) is necessary for earth continuity testing.
Memory function	ACW	Maximum of 100
	DCW (*6)	Maximum of 100
	IR	Maximum of 100
	AUTO	Maximum of 100 test patterns, with each having up to 100 steps (total of 500 steps)
Backup battery life		At least 3 years (at 25 °C)
MEASURE MODE		Displaying the measured current in withstanding voltage testing and the measured insulation resistance in insulation resistance testing can be selected as shown below
	NORM	Displays, during the test, the measured current in withstanding voltage testing and the measured insulation resistance in insulation resistance testing
	MAX/MIN	Displays, during the test, the maximum measured current in withstanding voltage testing and the minimum measured insulation resistance in insulation resistance testing during one test
PASS HOLD TIME		The time during which a PASS judgement is held can be set from 0.2 s to 10.0 s at a resolution of 0.1 s, or to HOLD.
TEST TIME	MOMENARY	Executes a test only while the START switch is pressed
	FAIL MODE	Cancels to reset the FAIL or PROTECTION status produced by the STOP signal with remote control
	DOUBLE ACTION	Starts a test only when the START switch is pressed within approximately 0.5 s after the STOP switch is pressed
KEYLOCK		Shifts to the status in which no keys other than the START and STOP switches are accepted

*6

The DCW (DC withstanding voltage testing) function is provided only for TOS9201.

General Specifications (TOS9200/TOS9201)

Item	Specifications	
Environment		
Installation location	Indoors at an altitude of up to 2000 m	
Warranty range	Temperature	5 °C to 35 °C (41 °F to 95 °F)
	Humidity	20 % to 80 % RH (No condensation)
Operating range	Temperature	0 °C to 40 °C (32 °F to 104 °F)
	Humidity	20 % to 80 % RH (No condensation)
Storage range	Temperature	-20 °C to 70 °C (-4 °F to 158 °F)
	Humidity	90 % RH or less (No condensation)
Power requirements		
Nominal voltage range (Allowable voltage range)	100 V to 120 V AC / 200 V to 240 V AC (85 V to 130 V AC / 170 V to 250 V AC) Selectable	
Power consumption	Using no load (READY)	100 VA or less
	Using the rated load	Maximum of 800 VA
Allowable frequency range	47 Hz to 63 Hz	
Insulation resistance	30 MΩ or more (500 V DC) [between the AC LINE and chassis]	
Withstanding voltage	1500 V AC, 1 minute [between the AC LINE and chassis]	
Earth continuity	25 A AC/0.1 Ω or less	
Safety	Conforms to the requirements of the following standard. IEC 61010-1:2001 (Class I (*7), Pollution Degree 2 (*8))	
Dimensions	See Fig. 8-1 Dimensions.	
Weight	Approx. 19 kg (Approx. 41.89 lbs)	
Accessory		
AC Power cord	1 pc.	
High-voltage test leadwire TL01-TOS (1.5 m)	1 set	
Interlock jumper	1 pc.	
High-Voltage Danger sticker	1 sheet	
Fuse	1pc.	
Operation Manual	Operation Manual for Tester: 1 copy, Operation for GPIB/RS-232C Interface: 1 copy	

*7

This instrument is a Class I equipment. Be sure to ground the protective conductor terminal of the instrument. The safety of the instrument is not guaranteed unless the instrument is grounded properly.

*8

Pollution is addition of foreign matter (solid, liquid or gaseous) that may produce a reduction of dielectric strength or surface resistivity. Pollution Degree 2 assumes that only non-conductive pollution will occur except for an occasional temporary conductivity caused by condensation.

Dimensions

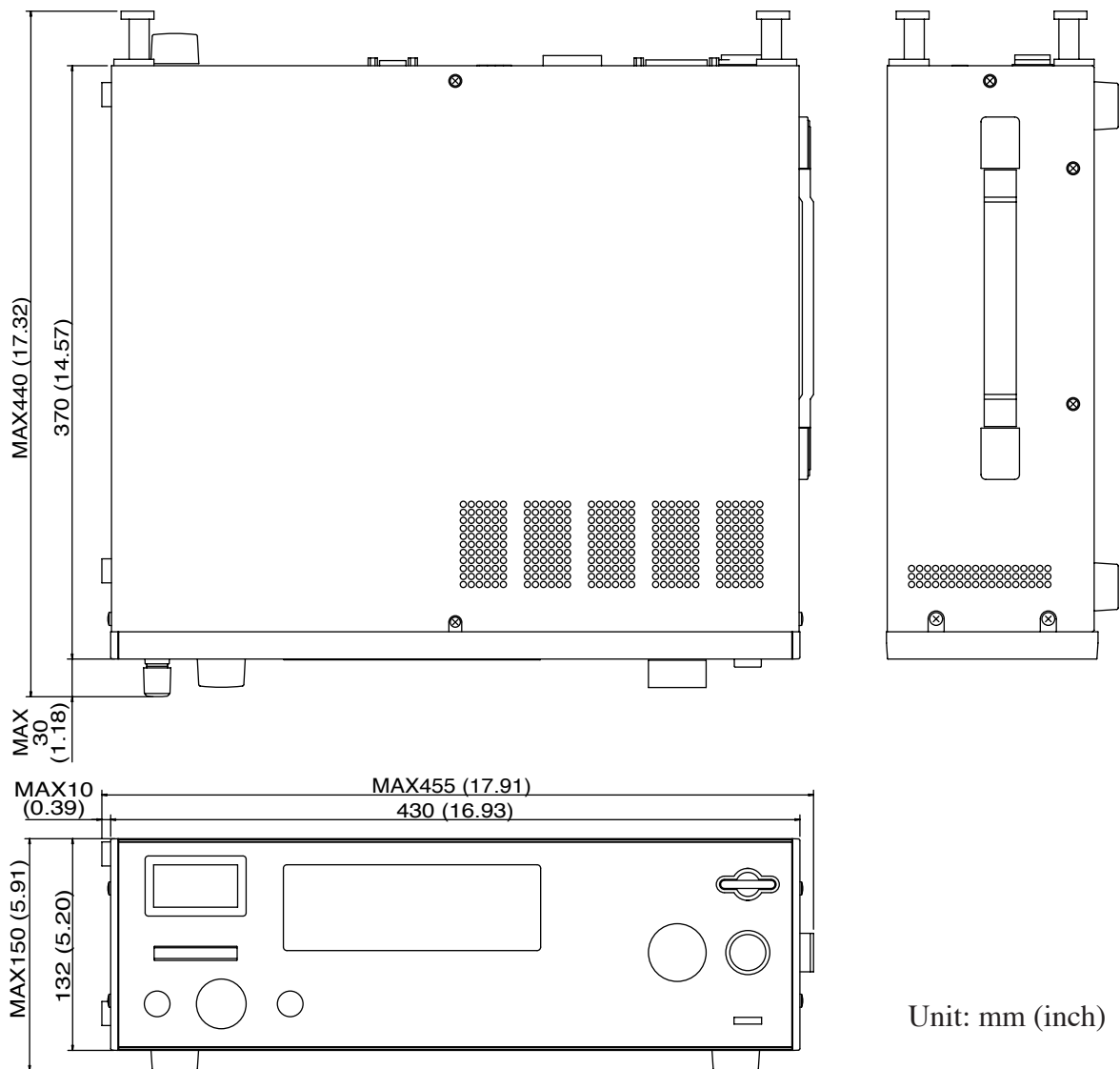

Fig.8-1 Dimensions



Appendix

1. Operating Principle

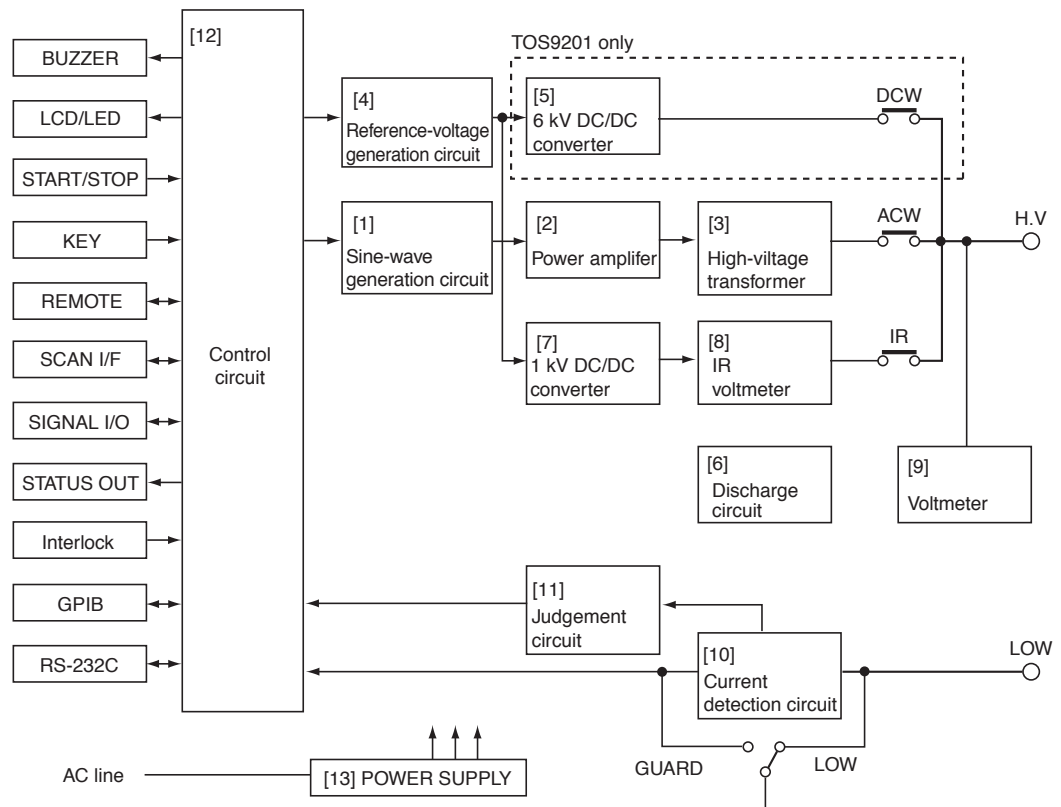

Fig.A-1 TOS9200/9201 block diagram

[1] Sine-wave generation circuit

In AC withstanding voltage testing, this circuit generates a slightly distorted 50 Hz or 60 Hz sine wave corresponding to the test voltage. During the preset voltage rise time (RISE TIME), the tester rises from zero to the preset test voltage while applying no transient voltage stress to the DUT. When the test ends with a PASS judgement, the tester falls from the test voltage to zero during the preset voltage fall time (FALL TIME).

[2] Power amplifier

The large-capacity (500 VA), high-efficiency PWM switching amplifier amplifies the output from the sine-wave generation circuit up to a consistent maximum of 100 V.

Although it is subject to time limitations, the tester's high-voltage generation block, including a high-voltage transformer, can generate a rated maximum of 500 VA (5 kV/100 mA), or 2.5 times that of Kikusui's conventional counterparts. The amplifier generates a consistent test voltage of 50 Hz/60 Hz independent of the supply voltage, with a voltage regulation within $\pm 3\%$. Further, at a test voltage of 500 V or more, it is capable of supplying a momentary current of at least 200 mA.

[3] High-voltage transformer

Increases the output voltage for the power amplification circuit to a maximum of 5 kV at a ratio of 1 to 50. Has a transformer capacity as large as 500 VA.

[4] Reference-voltage generation circuit

Generates a reference voltage corresponding to the test voltage in DC withstanding voltage testing and insulation resistance testing. During the preset voltage rise time (RISE TIME), the reference voltage increases from zero to the preset test voltage, exerting little transient voltage stress on the DUT.

[5] 6 kV DC/DC converter (TOS9201 only)

The high-voltage generation circuit for DC withstanding voltage testing. At an output of 6 kV, the converter enhances the output from the reference-voltage generation circuit by approximately 300 times to obtain 1.25 kV. Further, it achieves 6 kVDC in the 4-time Cockcroft and Wolton circuit. The converter realizes a low-ripple stable test voltage of up to 6 kV (maximum rated power of 50 W) with a voltage regulation of 1 % or less.

[6] Discharge circuit

Equipped with a function for forcibly releasing a charge in the DUT contained at the end of a DC withstanding voltage test or an insulation resistance test, thus preventing electric shock.

[7] 1 kV DC/DC converter

High-voltage generation circuit for insulation resistance testing. At an output of 1000 V, the converter enhances the output from the reference-voltage generation circuit by approximately 200 times to obtain 1000 V. At -25 V to -1000 V (a maximum rated current of 1 mA), the converter realizes a low-ripple stable test voltage with a voltage regulation of 1 % or less.

[8] IR voltmeter

Digital voltmeter for insulation resistance testing with an accuracy of $\pm(1\%$ of reading + 1 V). The output voltage is divided using a high-precision, high-voltage resistor. These voltages are input to the A/D converter and displayed on the LCD during the test. The insulation resistance is obtained by dividing voltage by current which detected on the current detection circuit in the insulation resistance meter.

[9] Voltmeter

Equipped with a high-precision digital voltmeter with an accuracy of $\pm(1\%$ of reading + 30 V) and an analog voltmeter with an accuracy of $\pm 5\%$ f.s.

(a) Digital voltmeter

The digital voltmeter divides the output voltage using a high-precision high-voltage resistor, and converts divided voltages into DC voltages in the AC/DC conversion circuit. These voltages are collected by the A/D converter and displayed on the LCD

during the test. The voltmeter constantly monitors the voltage on the output terminal, even when no test is under way. When a voltage is detected, the voltmeter turns on the DANGER lamp.

(b) Analog voltmeter

Rectifies currents flowing into divider resistors, and drives the DC voltmeter. Conducts voltage measurement in AC/DC withstanding voltage testing, as well as insulation resistance testing.

[10] Current detection circuit

(a) Current detection circuit for withstanding voltage testing

Converts the current flowing into the output terminal into a voltage using the reference resistance, and further transforms it into a DC voltage in the AC/DC conversion circuit. This voltage is input to the A/D converter and displayed on the LCD. Compared with Kikusui's conventional counterparts, which have a measurement resolution of 1 mA and accuracy of $\pm 5\%$ of the upper current when the upper current is set to 100 mA, this tester enables measurement with an accuracy of $\pm(3\%$ of reading + 20 μA) to be conducted even at an upper current of 100 mA.

(b) Current detection circuit for insulation resistance testing

Converts the current flowing into the output terminal into a voltage in the current-voltage conversion circuit, and collects it in the A/D converter. The insulation resistance value is determined by dividing the voltage measured on the voltmeter for insulation resistance testing by the current obtained in this current detection circuit. The insulation resistance value is then displayed on the LCD.

[11] Judgement circuit

In withstanding voltage testing, this circuit compares the DC current measured in the current detection circuit with the reference voltage, which corresponds to the preset upper or lower current. If a current exceeding the upper current is detected, the circuit determines that a withstanding voltage error has occurred and cuts off the test voltage. In addition, if detected currents are below the lower current, the circuit determines that the high-voltage test leadwire is disconnected or in poor contact, and thus cuts off the test voltage.

[12] Control circuit

Controls the test voltage. This circuit also manages voltage measurement, current measurement, judgement, and test time, in addition to conducting sequence control on the CPU.

[13] POWER SUPPLY

Converts AC voltages from an AC line into DC voltages in order to supply them to circuits

2. ASCII Code 20H to 7EH

These characters can be used for the title names in panel memory and program memory and comments.

Turn the rotary knob counterclockwise to enter ASCII code [] (20H). Turn the rotary knob clockwise to enter ASCII code [~] (7E).

NOTE

- The tester does not accept [“] (22H), [‘] (27H), [,] (2CH), or [@] (40H).
-

```
! " # $ % & ' ( ) * + , - . /
0 1 2 3 4 5 6 7 8 9 : ; < = > ?
@ A B C D E F G H I J K L M N O
P Q R S T U V W X Y Z [ \ ] ^ _
` a b c d e f g h i j k l m n o
p q r s t u v w x y z { | } ~
```

Index

Numerics

149-10A 3-16, 3-28, 3-40

A

a total of 500 steps 3-65
abnormal 24-V output 3-74
AC LINE 6-7
accessories 1-2
Action 2-2
ACW/OFFSET 6-2
analog voltmeter 3-2, 6-3
AUTO/EDIT 6-3

B

backup battery 7-2
baud rate 3-61
BUZZER 3-58
buzzer volume 3-58

C

C FAIL 3-60
calibration 7-2
CH INVALID 3-70
channel 3-18, 3-30, 3-42
Class I device 1-8
cleaning 7-1
COMMENT 3-60
comment 3-60
communication error 5-6
communication error during TOS6200 control
3-75
CONTRAST 3-58
cooling fan 7-2
cord holder 6-8
coronal discharge 3-14
current-detection response speed 3-13
CURSOR 6-5

D

daily checking 2-6
DANGER lamp 6-4
data length 3-62
DCW 6-2
discharge time 2-4
DOUBLE ACTION 3-58

E

emergency 2-2
END 3-68
ending the test 3-49

F

FAIL judgement 3-50
FAIL MODE 3-57
failed tester 2-5
FALL TIME 3-12
FAST 3-14
flashover 3-14
For your own safety P-II
FUNCTION 6-2
FUSE 1-5, 1-6, 6-7

G

GPIB 6-7
GPIB address 3-61
grounding 1-8
GUARD 3-16, 3-28, 3-40

H

H.V ON 3-59
HIGH VOLTAGE terminal 6-4
high-voltage relay 7-2
high-voltage scanner P-9
high-voltage test probe 4-1
HP01A-TOS P-8, 4-2
HP02A-TOS P-8, 4-2

I

indicator 6-2
initialization 3-76
insertion/extraction of the scanner connector 3-71
inspection 7-1
insulation glove 2-2
insulation-resistance test voltage 3-33
interface 3-61, 5-2
INTERLOCK 1-9, 3-71, 6-7
INTERLOCK connector 4-1, 4-11
INTERLOCK signal 3-71
internal memory 3-62
internal power fault 3-71
interval time 3-67
invalid settings 3-70
IR 6-3

K

KEY LOCK 3-69

L

L FAIL 3-60
LCD 6-3
LINE 1-5
LINE VOLTAGE RANGE 6-7
LINE-VOLTAGE RANGE switch 1-5
LOCAL/KEYLOCK 6-2
LOW 3-16, 3-28, 3-40
LOW terminal 6-4, 6-6
LOW/GUARD 3-15, 3-27, 3-39, 5-2, 6-4
LOWER 3-7, 3-22, 3-34

M

maintenance 7-2
MEAS MODE 3-56
measurement mode 3-56
MEMORY 6-3
MID 3-14
MOMENTARY 3-56
monitoring of AC power 3-72

O

offset cancel 3-9, 3-53
options P-7
OUTPUT 6-6
output-power limiting function 3-73
output-voltage monitoring function 3-73
output-voltage ranges 3-13
OVER 1.1 mA 3-70
OVER 55 W 3-70
OVER 550 VA 3-70
OVER WAIT 3-70
overheat protection 3-74

P

panel memory 3-62
parity 3-62
PASS 3-60
PASS HOLD 3-56
PASS hold time 3-56, 5-2
PASS judgement 3-49
PM signals 4-10
POWER 6-1
power cord 1-7
POWER ON 3-60
precautions for installation 1-3
precautions for moving 1-4
precautions on testing 2-2
program 3-65
prohibited operations 2-1
PROTECT 3-60
protection 3-71
protective conductor terminal 6-8

R

RC01-TOS P-7, 4-2
RC02-TOS P-7, 4-2
READY 3-60
recall 3-64
RECALL/STORE 6-3
reducing the effects of noise 3-45
REMOTE 3-72, 4-1, 4-2

REMOTE terminal 6-4
remote-control box 4-1
residual high voltages 2-4
RESPONSE 3-13
RET 3-68
RISE TIME 3-12, 3-26, 3-38
ROM version P-I
rotary knob 6-5
RS-232C 6-6

S

SCANNER 6-7
setting the repeat test 3-68
settings for AC withstanding voltage testing 3-4
SHIFT 6-4
SIGNAL I/O 6-7
SIGNAL I/O connector 4-1, 4-5
SIGNAL I/O signal 3-72
SLOW 3-14
source voltage 1-5
START 6-2
start voltage 3-11, 3-25
starting a test 3-46, 4-8, 5-4
STATUS OUT 6-6
STATUS OUT connector 4-1, 4-13
STATUS SIGNAL OUTPUT 3-59
STOP 6-1
stop bit 3-62
storing 3-62
stray capacity 3-53
strobe signal 4-9
system 3-55

T

TEST 3-59
test frequency 3-5
test judgement 5-5
test leadwire 3-44
TEST TIME 3-10, 3-24, 3-37
test voltage for DC withstanding voltage testing
3-21

the lower current 3-7, 3-22, 3-34
the upper current 3-8, 3-23, 3-36
time restriction by the output current 3-74
timing chart 3-49
To supervisor in charge of operation P-II
TOS1200 3-16, 3-28, 3-40
TOS6200 3-17, 3-29, 3-41, 5-1
TOS6200 protection 3-75
TOS9220/TOS9221 P-9
troubleshooting 7-3
turning the contact check ON/OFF 3-19, 3-31,
3-43
turning the lower judgement function ON/OFF
3-6, 3-21, 3-33
turning the timer ON/OFF 3-9, 3-24, 3-37
turning the upper judgement function ON/OFF
3-35

U

U FAIL 3-60
unpacking 1-1
UP \leq LOW 3-70
UPPER 3-8, 3-23, 3-36

V

voltage fall time 3-12
voltage rise time 3-12, 3-26, 3-38

W

WAIT TIME 3-26, 3-38



If you find any misplaced or missing pages in the manuals, they will be replaced. If the manual gets lost or soiled, a new copy can be provided for a fee. In either case, please contact your Kikusui agent or distributor. At that time, inform your agent or distributor of the "Part No." written on the front cover of this manual.

Every effort has been made to ensure the accuracy of this manual. However, if you have any questions or find any errors or omissions, please contact your Kikusui agent or distributor.

After you have finished reading this manual, store it so that you can use it for reference at any time.

KIKUSUI ELECTRONICS CORP.

1-1-3 Higashiyamata, Tsuzuki-ku, Yokohama,
224-0023, Japan

Tel: +81-45-482-6353 Fax: +81-45-482-6261



Website

<http://www.kikusui.co.jp/en>