



Setup Guide

Withstanding Voltage Tester

TOS5200



Thank you for purchasing the TOS5200 Withstanding Voltage Tester.

Notes to the Supervisor

- If the operators cannot understand the language used in this manual, translate the TOS5200 manuals¹ into the appropriate language.
- Make sure that the operators understand the information in the TOS5200 manuals¹ before they operate the product.
- Keep the TOS5200 manuals¹ close to the product so that the operators can read them at any time.
- If the tester will be used to repeatedly perform tests with fixed conditions, such as when being used as part of a manufacturing line, attach the protection cover to ensure safe operation of the tester. This is useful in preventing incorrect operation of the tester.

1: See "About the TOS5200 Manuals" on page 2.



DANGER

This product generates high voltage!

- Improper operation can lead to serious accidents.
- To prevent accidents, be sure to read the section "Safety Precautions during Testing" in this setup guide.
- Keep this setup guide close to the product so that the operators can read the manual at any time.

Dangerous Operations

You will receive a potentially fatal electric shock if:

- You touch an output terminal while output is being generated.
- You touch a test lead that is connected to an output terminal while output is being generated.
- You touch the device under test (DUT) while output is being generated.
- You touch a location that is electrically connected to an output terminal while output is being generated.

You may receive a potentially fatal electric shock if:

- You operate the tester without grounding it.
- You operate the tester without using rubber gloves for electrical work.
- You come close to a location that is electrically connected to an output terminal while output is being generated.

KIKUSUI ELECTRONICS CORP.

1-1-3 Higashiyamata, Tsuzuki-ku, Yokohama,
224-0023, Japan
Tel: +81-45-593-7570 Fax: +81-45-593-7571

Website <http://www.kikusui.co.jp/en>

The newest version of the TOS5200 manuals can be downloaded from Download service of Kikusui website.



About the TOS5200 Manuals

The following manuals are provided for the TOS5200 Withstanding Voltage Tester.

■ User's Manual (PDF)

This manual is intended for first-time users of this product. It provides an overview of the product, notes on usage, and specifications. It also explains how to connect the product, configure the product, operate the product, perform maintenance on the product, and so on.

■ Communication Interface Manual (PDF)

This manual explains how to control the product remotely using SCPI commands.

The interface manual is written for readers with sufficient basic knowledge of how to control measuring instruments using a PC.

■ Quick Reference

The quick reference briefly explains the control panel and the basic operation of it.

■ Setup Guide (this guide)

This manual is intended for first-time users of the product. It gives an overview of the product, connecting procedures, safety precautions, etc. Please read this manual before you operate the product.

■ Safety Information

This document contains general safety precautions for this product. Keep them in mind and make sure to observe them.

These manuals are intended for users of the Withstanding Voltage Tester and their instructors. Explanations are given under the presumption that the reader has knowledge related to electricity.

PDF files are included in the accompanying CD-ROM. You can view the PDF files using Adobe Reader.

Every effort has been made to ensure the accuracy of this manual. However, if you have any questions or find any errors or omissions, please contact your Kikusui agent or distributor.

If you find any misplaced or missing pages in the manuals, they will be replaced. If the manual gets lost or soiled, a new copy can be provided for a fee. In either case, please contact your Kikusui agent or distributor. At that time, inform your agent or distributor of the "Part No." written on the front cover of this manual.

After you have finished reading this manual, store it so that you can use it for reference at any time.

Contents of the included CD-ROM

Load the included CD-ROM into the CD-ROM drive. In a few moments, a start window will appear. If the start window does not appear, open the CD-ROM folder in Windows Explorer, and then double-click index.html to display the start window.

The CD-ROM contains the following items.

- KI-VISA driver
- User's Manual (PDF)
- Quick Reference (PDF)
- Setup Guide (PDF)
- Communication Interface Manual (PDF)
- Description of the Safety Evaluation Test (PDF)



Notations used in this manual

- The TOS5200 Withstanding Voltage Tester is also referred to as the TOS5200.
- Device under test is also referred to as DUT.
- The term "PC" is used to refer generally to both personal computers and workstations.
- The following markings are used in the explanations in this manual.

⚠ WARNING

Indicates a potentially hazardous situation which, if ignored, could result in death or serious injury.

⚠ CAUTION

Indicates a potentially hazardous situation which, if ignored, may result in damage to the product or other property.

—Note—

Indicates information that you should know.

SHIFT+key name (blue letters)

Indicates an operation that requires you to press a key indicated in blue letters while holding down SHIFT.

Checking the Package Contents

When you receive the product, check that all accessories are included and that the accessories have not been damaged during transportation. If any of the accessories are damaged or missing, contact your Kikusui agent or distributor. We recommend that you save all packing materials, in case the product needs to be transported at a later date.

Accessories



Rating: 125 Vac, 10 A
Plug: NEMA5-15
[85-AA-0003]

or

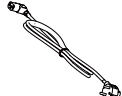

Rating: 250 Vac, 10 A
Plug: CEE7/7
[85-AA-0005]

or

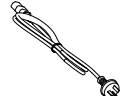

Rating: 250 Vac, 10 A
Plug: GB1002
[85-10-0790]

- Power cord (1 pc.)
Length: Approx. 2.5 m

The power cord that is provided varies depending on the destination for the product at the factory-shipment.



- High-voltage test lead (1 set)
[TL31-TOS]



- High-voltage warning sticker (1 pc.)
[A8-210-203]



- SIGNAL I/O plug (1 set)
Assembly type (D-sub plug unit)



- CD-ROM (1 pc.)



- Quick Reference

Japanese (1 pc.)
English (1 pc.)

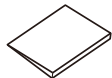

- Setup Guide (1 pc.)

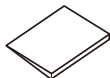

- Safety information (1 pc.)

Product Overview

The TOS5200 Withstanding Voltage Tester performs withstanding voltage tests, which is one of the four types of tests² that are required for ensuring the safety of electrical products.

This product can perform AC withstanding voltage tests on electrical products and electrical components in accordance with the requirements of safety and electrical standards and ordinances such as IEC, EN, UL, VDE, and JIS.

It is suited to (1) research and development installations, (2) test facilities for quality assurance testing and standard certification, and (3) manufacturing lines.

The withstanding voltage tester is easy to use, safe, and reliable.

²: The four types of tests are the withstanding-voltage, insulation-resistance, earth-continuity, and leakage-current tests.

Features

- Newly developed constant-voltage output for stable testing

The TOS5200 is not affected by AC line interference. Because the output voltage is maintained at a fixed value even if the AC line voltage or frequency changes, stable tests can be performed even in locations where the power supply is unstable.

The AC inlet is designed for worldwide use. The TOS5200 can be used without modification provided the nominal power supply voltage is within the range of 100 Vac to 240 Vac (90 Vac to 250 Vac) and the frequency is within the range of 47 Hz to 63 Hz.
- Rise time control feature that gradually increases the test voltage

Instead of immediately applying the specified test voltage to the DUT after the test begins, this makes it possible to perform tests in which the voltage is raised gradually to the test voltage. As required by withstanding voltage tests defined by standards such as IEC and UL, this makes it possible to perform tests in which no more than half of the test voltage is applied at the start of the test, and the test voltage is gradually reached over the specified time.
- Fall time control feature that gradually decreases the test voltage

The test voltage can be gradually decreased after a PASS judgment occurs during an AC withstanding voltage test.
- Window comparator feature for setting upper and lower judgment limits

You can set not only the upper limit, but the lower limit as well. This is useful in determining whether there are breaks in test leads or whether there was a mistake during operations. This leads to highly reliable tests.
- Ability to save three sets of test conditions

You can save three sets of test conditions.
- Improved safety

In addition to having features that enable you to view the output voltage, the TOS5200 also enables you to set the voltage limits, so you can prevent a voltage greater than what is necessary from being generated unintentionally. This provides protection for the DUT.
- Standard-equipped USB port

The TOS5200 is standard-equipped with a USB interface. You can use a PC or sequencer to control test conditions and read measured values and test results.
- Light-weight and easy to move

Even though the TOS5200 can generate 500 VA, which is sufficient for performing withstanding voltage tests, it only weighs 15 kg or less, so it can be moved by even a single person.
- Protection against incorrect operations

In addition to the key lock feature, the TOS5200 has a protection cover for the part of its panel that is used to change test conditions. This cover is useful in preventing incorrect operations when you want to perform tests with fixed conditions.

Precautions Concerning Installation Location

When installing this product, be sure to observe the precautions provided in “Precautions Concerning Installation Location” and “Precautions to Be Taken When Moving the Product” in the Safety information manual. The following precautions pertain only to this product.

- When installing this product, be sure to observe the temperature and humidity ranges indicated below.

Operating temperature range: 0 °C to +40 °C (32 °F to 104 °F)

Operating humidity range: 20 %rh to 80 %rh (no condensation)

- When storing this product, be sure to observe the temperature and humidity ranges indicated below.

Storage temperature range: -20 °C to +70 °C (-4 °F to 158 °F)

Storage humidity range: 90 %rh or less (no condensation)

- Do not use the product in a poorly ventilated location.

The product uses forced air cooling. It sucks air through the inlet holes on its right, and left panels, and then expels air through its rear panel. Secure adequate space around the product's inlet and outlet holes to prevent the possibility of fire caused by accumulation of heat.

Allow at least 20 cm of space between the inlet and outlet holes on the side panels and the walls (or obstacles).

Hot air (approximately 20 °C, 68 °F, hotter than the ambient temperature) is expelled from the outlet holes. Do not place objects that are affected by heat near the air outlet.

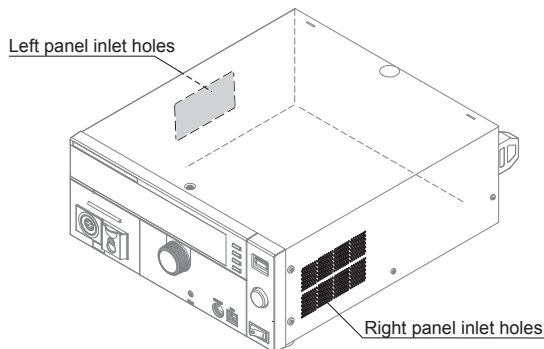

- Do not use this product near highly sensitive measuring instruments or receivers.

Noise generated by this product may affect other devices. At a test voltage of 3 kV or greater, the product may produce corona discharge between its test lead clips. This will generate a significant amount of broadband RF emission. To minimize this effect, keep the alligator clips away from each other. Also, keep the alligator clips and test leads away from conducting surfaces, especially sharp metal edges.

Using the Protection Cover

When the product is shipped from the factory, a protection cover is attached to the front panel. This cover prevents unintentional changes to the test conditions. Remove this cover when you want to set the test conditions.

Even when the cover is attached, you can still recall settings from memory, start and stop tests, perform remote operations, and control the TOS5200 through its USB port. If the tester will be used to repeatedly perform tests with fixed conditions, such as when being used as part of a manufacturing line, attach the protection cover to ensure safe operation of the tester. This is useful in preventing incorrect operation of the tester.

If the cover is damaged or lost, contact your Kikusui agent or distributor.

Removing the protection cover

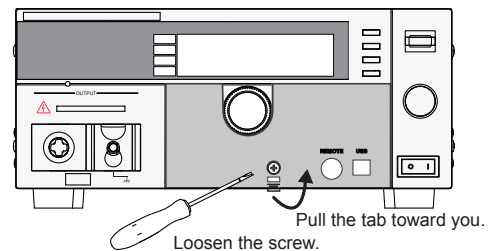

Loosen the screw, and then pull the tab at the bottom center of the cover towards you to remove the protection cover from the panel.

Attaching the protection cover

Insert the tabs at the top of the cover into the slots in the panel, push the bottom part of the cover until it is attached to the panel, and then use the screw to fix the cover in place.

Storing the protection cover

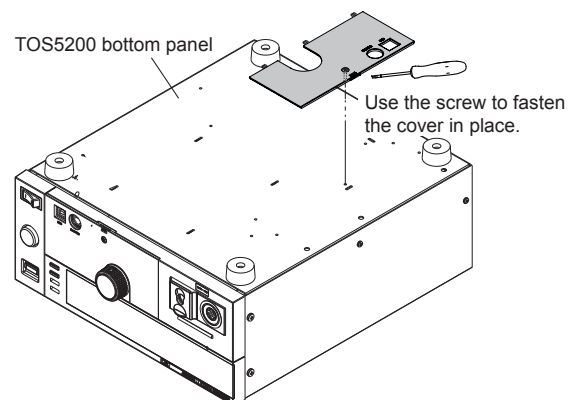

When you want to use the TOS5200 without the protection cover attached, such as when you will repeatedly perform tests with frequently changed test conditions, you can store the protection cover on the product's bottom panel. This is useful in preventing the cover from being lost.

Use the screw to fix the cover to the product's bottom panel.

Connecting the Power Cord

⚠ WARNING

Risk of electric shock.

- This product conforms to IEC Safety Class I (equipment that has a protective conductor terminal). Be sure to earth ground the product to prevent electric shock.
- Connect the protective conductor terminal to earth ground.

—Note—

- Use the supplied power cord to connect to the AC line. If the supplied power cord cannot be used because the rated voltage or the plug shape is incompatible, have a qualified engineer replace it with an appropriate power cord that is 3 m or less in length. If obtaining a power cord is difficult, contact your Kikusui agent or distributor.
- The power cord with a plug can be used to disconnect the product from the AC power line in an emergency. Connect the plug to an easily accessible power outlet so that the plug can be removed from the outlet at any time. Be sure to provide adequate clearance around the power outlet.
- Do not use the supplied power cord with other instruments.

This product conforms to IEC Overvoltage Category II (energy-consuming equipment that is supplied from a fixed installation).

In addition to the supplied power cord, Kikusui also provides other 200 V power cords with plugs (sold separately).

- 1 Check that the POWER switch is turned off.**
- 2 Check that the AC power line meets the nominal input rating of the product.**

The product can receive a nominal power supply voltage in the range of 100 Vac to 240 Vac (90 Vac to 250 Vac) that has a frequency in the range of 47 Hz to 63 Hz.
- 3 Connect the power cord to the rear-panel AC inlet, and then connect the power plug to an outlet that has a ground terminal.**

Turning the Power On

Checking indicators and the status of the interlock feature

The first time that you turn the POWER switch on after you purchase the TOS5200, the tester will be in PROTECTION mode through the interlock feature. Connect the included SIGNAL I/O plug to the SIGNAL I/O connector to release the interlock feature.

Only use the included SIGNAL I/O plug to easily release the PROTECTION mode.

- For details, see “Interlock Feature” in the user’s manual contained in the accompanying CD.

When you are actually performing tests, use the interlock feature to ensure safety.

During withstanding voltage tests in which you are using tools, (1) placing a cover over the DUT so that output is turned off whenever the cover is removed to prevent electric shock and (2) placing a safety fence around the work area where withstanding voltage tests are being performed so that output is turned off whenever the fence is opened are both examples of effective safety measures.

—Note—

When the TOS5200 is turned on, a self-test is run, and all the indicators on the front panel light. To ensure safety, check that all the indicators light before you use the TOS5200. It is especially dangerous to use the tester if its DANGER LED is broken. When the power is turned on, the DANGER LED lights, but no voltage is generated.

- 1 Check that the power cord and all cables are correctly connected.**
- 2 Check that nothing is connected to the SIGNAL I/O connector.**
- 3 Press the (I) side of the front-panel POWER switch to turn the TOS5200 on.**

Check that all the front-panel indicators light. The firmware version screen will be displayed for a few seconds, and then a message indicating that the TOS5200 is in PROTECTION mode will be displayed. Check that the tester is in PROTECTION mode through the interlock feature.

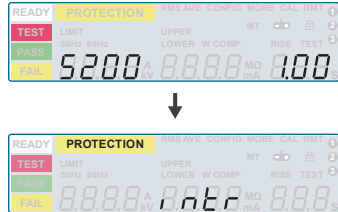

Firmware version screen

Interlock protection screen
- 4 Press the (O) side of the front-panel POWER switch to turn the TOS5200 off.**

Turning the Power On (Continued)

Turning the POWER switch on

1 Connect the included SIGNAL I/O plug to the SIGNAL I/O connector.

Connecting the SIGNAL I/O plug will release the interlock feature.

2 Press the (I) side of the power switch to turn the TOS5200 on.

3 Check the firmware version (Ver x.xx) that is displayed on the screen.

Check that the firmware version screen is displayed for a few seconds, that the setup screen for setting the AC withstanding voltage test conditions is displayed thereafter, and that the tester is then in READY mode (that the READY LED lights).

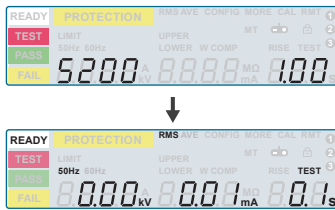

The first time that the POWER switch is turned on, the firmware version is displayed, and then the setup screen for setting the AC withstanding voltage test conditions is displayed (with the factory default settings).

- For details, see appendix, "Default Settings" in the user's manual contained in the accompanying CD.

The product stores the settings that are in use before it is turned off, so the next time that the POWER switch is turned on, the TOS5200 starts with these settings.

Turning the POWER switch off

1 Press the (O) side of the POWER switch to turn the TOS5200 off.

The panel settings that were in use immediately before the POWER switch was turned off are saved. If the POWER switch is turned off immediately after the settings have been changed, the last settings may not be stored.

! WARNING

Risk of electric shock.

- After you turn the POWER switch off, wait at least 10 seconds before you turn the POWER switch back on. It is dangerous to do otherwise, because the protective features of the product may not work effectively. This may cause the product to malfunction, and it may reduce the life of the POWER switch and internal parts such as the fuses.
- Except in an emergency, do not turn the POWER switch off while output is being generated.

Connecting to the Device under Test (DUT)

! WARNING

Risk of electric shock.

- During testing (while the TEST LED or DANGER LED is lit), never touch the HIGH VOLTAGE terminal, test leads, or DUT.

Using test leads

! WARNING

Risk of electric shock.

- Parts of the included test leads near the alligator clips protrude from the vinyl insulation when the wires are connected. These parts are dangerous. Never come close to these parts during testing.
- If connections are incomplete, the entire DUT may be charged to a high voltage. This is dangerous, so be sure to connect the DUT correctly.
- Be sure to connect the low-voltage test lead (black) first.

Never come close to this area during testing.

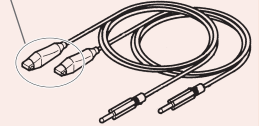

1 Check that the POWER switch is off and that the DANGER LED is off.

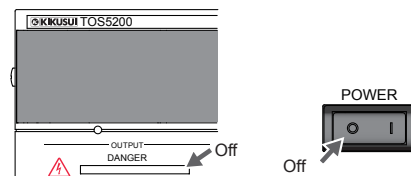

2 Check that there are no tears or breaks in the test lead insulation.

3 Raise the front-panel LOW VOLTAGE terminal's cable lock, and then connect the low-voltage test lead (black).

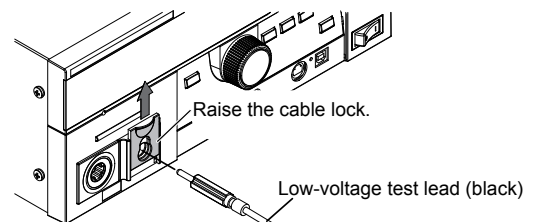

4 Lower the cable lock to secure the lead in place.

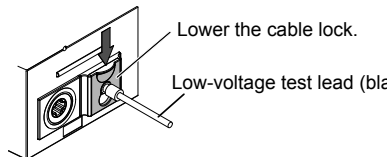

5 Connect the low-voltage test lead (black) to the DUT.

6 Connect the high-voltage test lead (red) to the DUT.

7 Connect the high-voltage test lead (red) to the front-panel HIGH VOLTAGE terminal.

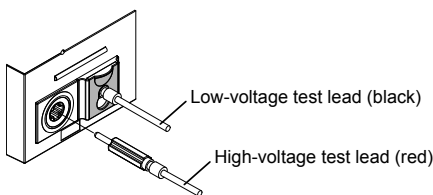

8 Check that the DANGER LED is turned off.

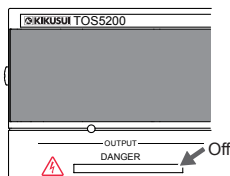

Reducing the effect of noise

Noise may be generated if the outputs are shorted or if the DUT insulation is damaged. Electronic devices in the surrounding area may malfunction due to the effect of this noise. To reduce the effect of noise, connect a toroidal core or a resistor of approximately $470\ \Omega$ between the tips of the high- and low-voltage test leads and the DUT. Connect the toroidal core or resistor as close to the DUT as possible.

If you are connecting a toroidal core, it is effective to wrap the test leads two to three times around a type of core that can be snapped on and that is often used with power cables. This type of core is usually approximately 20 mm in diameter.

If you are connecting a resistor, pay close attention to the power rating of the resistor. When the upper limit is 10 mA or less, connect a resistor of approximately $470\ \Omega$ (3 W, 30 kV impulse withstanding voltage). Because this resistor causes the voltage to fall, the voltage that is actually applied to the DUT is slightly lower than the voltage that is generated from the product's output terminals (when a 10 mA current flows, the voltage falls approximately 10 V).

These methods are extremely useful in reducing the effect of noise.

Connect the toroidal core or resistor as close to the DUT as possible.

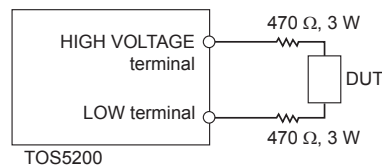
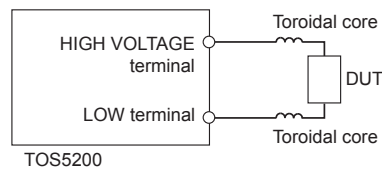

Using the optional high voltage test probe (model HP01A-TOS/HP02A-TOS)

If you use the optional test probe instead of the test leads, you can use hands-on control to start tests.

- For details, see the "OPERATION MANUAL HIGH VOLTAGE TEST PROBE HP01A-TOS/HP02A-TOS."

Disconnecting test leads from the DUT

- Check that the DANGER LED is off.
- Disconnect the high-voltage test lead (red) from the front-panel HIGH VOLTAGE terminal.
- Disconnect the high-voltage test lead (red) from the DUT.
- Disconnect the low-voltage test lead (black).
You can disconnect the low-voltage test lead (black) first from either the DUT or the TOS5200.

Safety Precautions during Testing

Pre-test inspection

⚠ WARNING

Risk of electric shock.

- **During testing, this product supplies a voltage of at least 5 kVac to an external device. Handling this tester improperly may lead to a fatal accident. To prevent accidents, strictly follow the precautions and always pay the utmost attention to safety concerns when you operate the TOS5200.**
- **This product conforms to IEC Safety Class I (equipment that has a protective conductor terminal). Be sure to earth ground the product to prevent electric shock.**
- **The product is grounded through the power cord ground wire. Connect the protective conductor terminal to earth ground.**
- **During testing, be sure to wear rubber gloves for electrical work.**

Check the following items before you start testing, and always follow the precautions.

- **The power cord is connected to a properly grounded outlet.**
- **There is no damage such as tears or breaks in the test lead insulation.**
- **When the POWER switch is turned on, the DANGER LED and the status indicators light.**
- **During testing, do not touch the items that are charged to a high voltage: the DUT, the test leads, and the areas near the output terminals.**
- **During testing, do not turn the POWER switch off except in an emergency.**

Testing precautions

During tests, the TEST and DANGER LEDs light. When these LEDs are lit, the TOS5200 is generating a high voltage. During testing, be sure to wear rubber gloves for electrical work. If obtaining these gloves is difficult, contact your Kikusui agent or distributor.

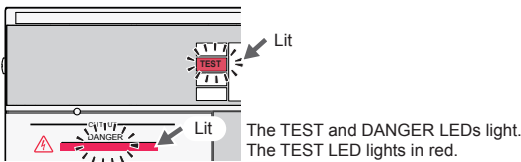

Remote control precautions

When you are controlling the TOS5200 remotely, external signals are used to turn the high voltage on and off. To prevent accidents, follow the safety measures given below.

- **Make sure that high voltages are not generated unintentionally.**
- **Make it impossible to touch the DUT, test leads, test probes, and the areas near the output terminals when high voltages are being generated.**

Interrupting testing or operations

Before you change test conditions or other settings, press the STOP switch, and then be sure to check the following items to ensure safety. If you will not use the product for some time or if the operator will be away from the product, be sure to turn the POWER switch off.

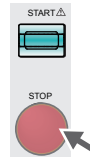

- **The TEST and DANGER LEDs are both off.**

Emergency measures

There are two actions that you must carry out if, due to a malfunction in the product or the DUT, there is a possibility of an emergency occurring such as electric shock or damage to the DUT.

- **Turn the POWER switch off.**

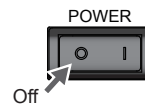

- **Remove the power cord plug from the outlet.**

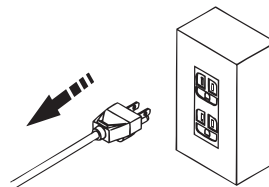

Forbidden actions

- **Turning the power on and off repeatedly**

After you turn the POWER switch off, wait for at least 10 seconds before you turn it back on. It is dangerous to do otherwise, because the protective features of the product may not work effectively. This may cause the product to malfunction, and it may reduce the life of the POWER switch and internal parts such as the fuses.

About malfunctions

WARNING

Risk of electric shock.

- Until you get the product fixed, make sure that nobody can use it.
- For repairs, contact your Kikusui agent or distributor.

If the TOS5200 is in one of the states explained below, it may be malfunctioning in a very dangerous manner—it may not be possible to turn off the high voltage that is being generated. If the tester is not operating properly, it may be generating a high voltage irrespective of the settings made by the operator.

Immediately turn the POWER switch off, and disconnect the power cord from the outlet. Stop using the product immediately, and contact your Kikusui agent or distributor.

- Even when you press the STOP switch, the DANGER LED remains lit.
- During tests, the DANGER LED does not light.

To use the product for a long time free of malfunctions

Taking size, weight, and cost into consideration, the heat dissipation capability of the voltage generator that is used for withstanding voltage tests has been designed to be one half that of the rated output. Use the TOS5200 within the following limits. If you use the product in a manner that exceeds these limits, the output section may overheat, and the internal protection circuits may be activated. If this happens, stop testing, and wait until the TOS5200 returns to its normal temperature.

- Output limits during withstanding voltage tests

Ambient temperature	Upper limit	Pause time	Output time
$t \leq 40\text{ }^{\circ}\text{C}$	$50\text{ mA} < i \leq 110\text{ mA}$	Greater than or equal to the output time	30 min. max.
	$i \leq 50\text{ mA}$	Not necessary	Continuous output possible

(Output time = voltage rise time + test time + voltage fall time)

Waste Electrical and Electronic Equipment (WEEE)

Disposing of used Kikusui products in the EU

Under a law adopted by member nations of the European Union (EU), used electric and electronic products carrying the symbol below must be disposed of separately from general household waste.



This includes the power cords and other accessories bundled with the products. When disposing of a product subject to these regulations, please follow the guidance of your local authority, or inquire with your Kikusui distributor/agent where you purchased the product.

The symbol applies only to EU member nations.

Disposal outside the EU

When disposing of an electric or electronic product in a country that is not an EU member, please contact your local authority and ask for the correct method of disposal.

Trademarks

All company names and product names used in this manual are trademarks or registered trademarks of their respective companies.

Copyrights

The contents of this manual may not be reproduced, in whole or in part, without the prior consent of the copyright holder.

The specifications of this product and the contents of this manual are subject to change without prior notice.

© 2014 Kikusui Electronics Corporation



环境保护使用期限 Environment-friendly Use Period

该标记为适用于在中华人民共和国销售的电子信息产品的环境保护使用期限。

只要遵守有关该产品的安全及使用注意事项，从制造年月起计算，在该年度内，就不会对环境污染、人身、财产产生重大的影响。

产品的废弃请遵守有关规定。

产品的制造年月可以在以下网址中确认。

<http://www.kikusui.co.jp/pi/>

有毒有害物质或元素名称及含有标示

Name of hazardous materials and symbol of element in the equipment and quantity

部件名称 Name of part	有毒有害物质或元素 Hazardous material and symbol of element					
	铅 Pb	汞 Hg	镉 Cd	六价铬 Cr(VI)	多溴联苯 PBB	多溴二苯醚 PBDE
印刷电路板组装机	×	○	○	○	○	○
显示器	○	○	○	○	○	○
内部接线	○	○	○	○	○	○
外壳	×	○	○	○	○	○
底盘组装机（含变压器）	×	○	○	○	○	○
辅助设备	×	○	○	○	○	○

本表格依据SJ/T 11364 的规定编制。

○：该部件所有均质材料的有毒有害物质的含量不超过GB/T 26572标准所规定的极限值要求。

×：该部件至少有一种均质材料的有毒有害物质的含量超过GB/T 26572标准所规定的极限值要求。