

# User's Manual

PLZ-5WH Series Electronic Load

**PLZ12005WH**

**PLZ20005WH**

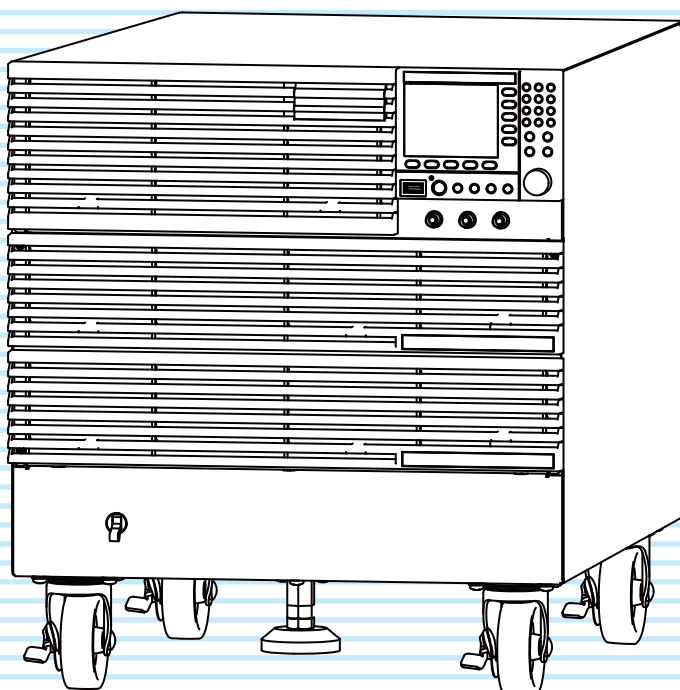

Contents 5

Component Names 8

Installation 12

Basic Functions 17

Advanced Functions 57

Sequence Function 80

External Control 99

Parallel Operation 111

System Settings 116

Maintenance 133

Specifications 134

Appendix 146









## About Manuals

These manuals provide an overview of the product and notes on usage. They also explain how to configure it, operate it, perform maintenance on it, and so on. Read manuals thoroughly before use, and use the product properly.

### Intended readers

Manuals are intended for users of the product or persons teaching other users on how to operate the product. The manual assumes that the reader has knowledge about power supplies.

### Manual construction

- User's manual  (this manual)  
This document is intended for first-time users of this product. It provides an overview of the product, notes on usage, and specifications. It also explains how to connect the product, configure the product, operate the product, perform maintenance on the product, and so on.
- Communication Interface Manual   
This document contains details about remote control. Interface manual is written for readers with sufficient basic knowledge of how to control measuring instruments using a personal computer.
- Quick Reference    
This document briefly explains the control panel and the basic operation of it.
- Setup Guide    
This document is intended for first-time users of the product. It gives an overview of the product, connecting procedures, safety precautions etc. Please read this manual before you operating the product.
- Safety Information    
This document contains general safety precautions. Keep them in mind and make sure to observe them.

PDF files is included in the accompanying CD-ROM. You can view the PDF files using Adobe Reader.

You can download the most recent version of these manuals from the Kikusui Electronics Corporation website.

### Firmware versions that this manual covers

This manual covers firmware versions 2.1X.

For information on how to check the current firmware version, see "Displaying the Device Information" ([p.132](#)).

When contacting us about the product, please provide us with:

- The model (marked in the top section of the front panel)
- Firmware version ([p.132](#))
- The serial number (marked on the rear panel)

## Trademarks

Microsoft is a registered trademark or trademark of Microsoft Corporation in the United States and/or other countries.

Other company names and product names used in this manual are generally trademarks or registered trademarks of the respective companies.

## Copyright

Reproduction and reprinting of this operation manual, whole or partially, without our permission is prohibited.

Both unit specifications and manual contents are subject to change without notice.

© 2018 Kikusui Electronics Corporation

## Open source software

This product contains open source software under the licensing terms of GNU General Public License (GPL), GNU LESSER General Public License (LGPL), and other licenses. For details, see the following URL.

<https://rddocuments.kikusui.co.jp/oss/plz5wh>

## Accessories

The attached power cord varies depending on the shipment destination.

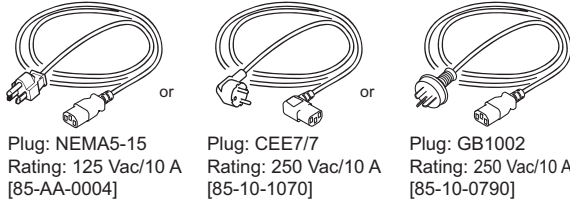

- Power cord (1 pc., length: 2.5 m)

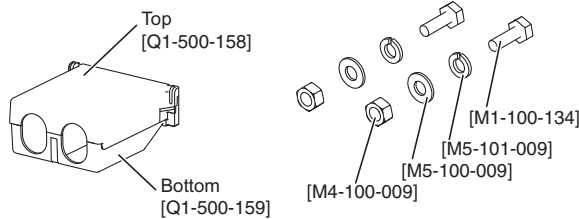

- Load input terminal cover (1 pc.)
- Load input terminal screw set (2 sets)

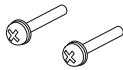

- Screws for the load input terminal cover (2 pcs.) [M3-112-016]

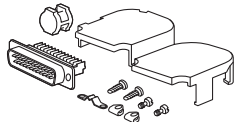

- External control connector kit (1 set) [83-20-0190]

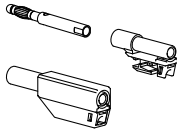

- Safety terminal adapter TL41 (red 1 set, black 1set) [87930]

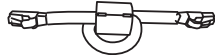

Cable length: Approx. 1 m

- Parallel operation signal cable kit [PC02-PLZ-5W]

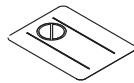

- Safety Information (1 pc.)
- Heavy object warning label (1 pc.)  
PLZ12005WH:[A8-900-156]  
PLZ20005WH:[A8-900-157]

- Setup Guide (1 copy)

- Quick Reference (English/Japanese, 1 sheet each)

- CD-ROM (1 disc)

## Product Overview

The PLZ12005WH/PLZ20005WH is a multifunctional system designed to offer the highest levels of reliability and safety. A high voltage large capacity load can be configured with this product set alone. The electronic load contains a stable and fast-response current control circuit that enables high-speed load simulations. Designed to allow high-precision current setting, it provides outstanding resolution.

The product is equipped with a color liquid crystal display (LCD) for easy viewing.

Because the electronic load comes standard with RS232C, USB, and LAN communication functions, it can easily be incorporated into a wide range of inspection systems.

### Model configurations

Model	Maximum operating current	Operating voltage	Power
PLZ12005WH	240 A	10 V to 800 V	12 kW
PLZ20005WH	400 A		20 kW

### Features

In addition to basic constant current, constant resistance, constant voltage, and constant power modes, the PLZ12005WH/PLZ20005WH offers a variety of other functions.

#### Larger capacity achievable in a compact form

The PLZ20005WH alone supports 20 kW. A compact load system can be configured. Up to four units can be operated in parallel using one of them as the master unit (up to 100 kW, 2000 A).

#### Wide operating voltage range

The operating voltage range is 10 V to 800 V. The minimum operating voltage at which current begins to flow is 1.5 V.

#### Pulse and sine functions

The pulse function repeatedly executes two settings. It is suitable for transient response characteristics testing of large capacity power supplies and batteries. The sine function varies the current sinusoidally.

#### Arbitrary I-V characteristics mode

Arbitrary I-V characteristics can be set by registering multiple I-V characteristic points (pairs of voltage and current values).

#### Cutoff function

The load can be turned off when the elapsed time from load-on, the voltage drop, the integrated current, or the integrated power reaches the specified value.

#### Synchronized Operation

Load on/off control and the execution of sequences can be synchronized among multiple PLZ12005WH/PLZ20005WH units.

#### Data logging function

The most recent measurements (current, voltage, power) are shown on the display. Further, measurements can be stored in internal memory.

#### RS232C, USB, and LAN communication functions provided as standard

These functions allow easy incorporation into various types of inspection systems.

## GPIB function available as option\*

Using the optional GPIB converter (p. 164), the GPIB function can be used via the RS232C or USB interface.

\* Limitation apply to some of the functions.

## Notations Used in This Manual

- In this manual, electronic load PLZ12005WH or PLZ20005WH is sometimes referred to as the PLZ12005WH/PLZ20005WH.
- The PLZ12005WH/PLZ20005WH has five operation modes: CC, CR, CV, CP, and ARB. The operation mode is sometimes simply referred to as the mode.
- The term "PC" is used to refer generally to both personal computers and workstations.
- The term "DUT" is used to refer generally to a device under test.
- The screen captures and illustrations used in this text may differ from the actual items.
- The following markings are used in this manual.

### ⚠ WARNING

Indicates a potentially hazardous situation which, if ignored, could result in death or serious injury.

### ⚠ CAUTION

Indicates a potentially hazardous situation which, if ignored, may result in slight injury or damage to the product or other property.

### NOTE

Indicates information that you should know.



Indicates a reference manual (CD-ROM) containing detailed information.



Indicates the hierarchy of items you need to select. The item to the left of this symbol indicates a higher level item.

## Safety Precautions

When using this product, be sure to observe the precautions in the Safety Information manual. Items specific to this product are given below.

### ⚠ WARNING

- Be careful of hearing loss.  
Wear earplugs when working near the PLZ12005WH or PLZ20005WH when it is running.  
The noise sound pressure level of this product is 80 dB or less, but when this product is operated in the same place as another product with a large noise sound pressure level or when several of this product is operated simultaneously in the same place, the pressure level near the product may exceed 80 dB.

### ⚠ CAUTION

- The exhaust air may become hot.  
Stay away from the exhaust air flow. Move this product away from installed objects to prevent the exhaust air from hitting them directly.

## Notes on Usage

- When installing this product, be sure to observe the temperature and humidity ranges indicated below.  
Operating temperature range: 0 °C to 40 °C (32°F to 104°F)  
Operating humidity range: 20 %rh to 85 %rh (no condensation)
- When storing this product, be sure to observe the temperature and humidity ranges indicated below.  
Storage temperature range: -25 °C to 60 °C (-13°F to 140°F)  
Storage humidity range: 90 %rh or less (no condensation)
- Adequately ventilate the room in which this product is installed to keep the room temperature from rising.
- Locking the casters and applying the stopper  
The PLZ12005WH and PLZ20005WH have casters on the bottom side, so it is easy to move the product. To ensure that the product is not moved accidentally while it is being operated, use the stopper to fix the product in place, and lock the casters with your foot.

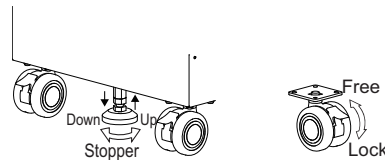

- When moving the product, be sure to release the stopper.  
Loosen the stopper nut, and turn the stopper shaft to raise its base up to the bottom of the product. Provide adequate space between the base of the stopper and the floor.  
Otherwise, the stopper may hit an obstacle while the product is being moved causing the stopper shaft to break.

# Contents

About Manuals .....	2
Open source software .....	2
Accessories .....	3
Product Overview .....	3
Notations Used in This Manual.....	4
Safety Precautions .....	4
Notes on Usage.....	4
Component Names .....	8

## Installation

Connecting the Power Cord .....	12
Turning the Power On or Off .....	13
Turning the power on.....	13
Turning the power off.....	13
Connecting to the DUT .....	14
Connecting to the load input terminals .....	14
Notes regarding load input terminals.....	16

## Basic Functions

Panel Operations.....	17
Switching the display .....	17
Using the function keys .....	18
Selecting items based on color markers.....	19
Operation example (Selection of constant resistance mode) .....	19
Inputting numbers and characters.....	20
Changing values.....	21
Load On/Off.....	22
Setting the Operation Mode .....	23
Setting the Operation Mode.....	23
Setting the current in CC mode .....	24
Setting the conductance in CR mode .....	25
Setting the resistance range of CR mode.....	26
Setting the voltage in CV mode .....	27
Setting the power in CP mode.....	28
Setting the I-V characteristics in ARB mode.....	29
Setting the Slew Rate.....	33
Pulse Function.....	34
Setting the pulse amplitude .....	34
Setting the pulse interval .....	35
Turning the pulse function on/off .....	36

Timing of trigger signal output.....	36
Sine Function .....	37
Setting the amplitude.....	37
Setting the Frequency .....	38
Turning the sine function on/off.....	39
Trigger signal timing.....	39
Alarm Function .....	40
Alarm types and operation .....	40
Setting overcurrent protection (OCP).....	42
Setting overpower protection (OPP).....	43
Setting undervoltage protection (UVP).....	44
Setting watchdog protection (WDP) .....	45
When an alarm occurs .....	46
Clearing an alarm.....	46
Recording Measurements .....	47
Starting measurement recording .....	47
Setting recording conditions .....	48
Aborting a measurement recording .....	51
Displaying the recorded measurement.....	52
Recording Integrated Data .....	53
Recording integrated current, integrated power, and elapsed time .....	53
Showing or hiding integrated data.....	55
Saving Measurement Data to USB Memory ....	56

## Advanced Functions

Changing the Response Speed .....	57
Soft Start .....	58
Remote Sensing.....	59
Connecting cables to the safety terminal adapters.....	59
Connecting the sensing cables .....	60
Enabling or disabling remote sensing .....	61
Cutoff function .....	62
Setting the cutoff activation condition.....	62
Cutoff operation.....	64
When cutoff is activated .....	65
Types of Memory .....	66
ABC Preset Memories.....	67
Saving to ABC preset memories .....	68
Recalling ABC preset memory entries .....	69
Setup Memory.....	70
How to view the setup memory edit screen.....	70
Saving to the setup memory.....	71
Checking the setup memory details .....	72

Recalling the setup memory.....	73
Synchronized Operation .....	74
Connection for synchronized operation (steps 1 to 4).....	74
Synchronizing the load on/off operation.....	76
Synchronizing measurement recording.....	76
Synchronizing the start of sequences .....	77
Synchronizing the resuming of sequences .....	78
Aborting synchronized operation.....	78
Remote Control .....	79
Releasing remote control .....	79

## Sequence Function

Overview of the Sequence Function.....	80
Programs and steps .....	80
Main functions .....	80
Program Configuration .....	81
How to view the program editing screen .....	81
Creating a program .....	81
Setting the number of loops .....	82
Setting protection functions.....	83
Setting the load state at the end of the sequence.....	84
Changing a program name .....	85
Deleting a program.....	85
Setting Steps .....	86
Creating steps .....	86
Deleting steps .....	89
Sequence creation tutorial.....	90
Creating Program1 as a new program .....	90
Registering steps to Program1.....	91
Executing a sequence.....	94
Aborting a sequence .....	95
Pausing a sequence.....	95
Controlling the start of sequences with triggers .....	95
Exporting and Importing Programs.....	97
Exporting programs to a USB memory device .....	97
Importing programs from a USB memory device .....	98

## External Control

Preparation for External Control.....	99
Precautions for use at high response speeds .....	99
EXT CONT connector pin arrangement.....	100
Connecting to the EXT CONT connector .....	101
Load Setting Control.....	102
Constant current (CC), constant resistance (CR), and constant power (CP) control.....	102
Constant voltage (CV) control .....	103
Controlling the current to be superimposed on the	

constant current (CC).....	104
Controlling Load On/Off.....	105
Load on/off control input .....	105
Load-on status signal output.....	106
Controlling Alarms .....	107
Alarm input.....	107
Alarm clearing input .....	107
Alarm status output.....	107
Trigger Input/Output .....	108
Trigger input.....	108
Trigger output.....	108
Digital I/O.....	109
Current and Voltage Monitor Signals .....	110

## Parallel Operation

Overview of Parallel Operation.....	111
Making connections for parallel operation .....	112
Performing parallel operation.....	114
Slew rate and response speed settings during parallel operation .....	114
Protection function during parallel operation (parallel operation anomaly detection).....	114
Changing from parallel operation back to standalone operation .....	115

## System Settings

Displaying and Changing CONFIG Settings ..	116
Remote sensing .....	116
Panel settings at startup .....	117
Watchdog protection setting (WDP).....	117
Screen saver.....	118
Key lock .....	119
Setting the beep sound.....	120
Setting the DIGITAL2 signal input/output.....	121
Displaying/Changing the Interface Settings ...	122
Resetting the interface settings.....	124
Returning the interface settings to the factory default values.....	124
Displaying SCPI Errors.....	125
Setting the Date/Time.....	126
Factory Default Settings and Reset Settings..	127
Restoring the factory default settings.....	127
Restoring the reset settings .....	128
Main settings at factory default and at reset .....	129
Updating .....	131
Displaying the Device Information.....	132

## Maintenance

Inspection .....	133
Overhaul .....	133
Backup battery replacement .....	133
Calibration .....	133

Low inductance cable .....	163
GPIB converter (PIA5100) .....	164
Rack mount bracket .....	164
Troubleshooting .....	167
Index .....	169

## Specifications

Ratings .....	134
Constant current (CC) mode .....	134
Constant resistance (CR) mode .....	135
Constant voltage (CV) mode .....	135
Constant power (CP) mode .....	135
Arbitrary I-V characteristics (ARB) mode .....	136
Measurement function .....	136
Pulse function .....	137
Sine function .....	137
Slew rate .....	138
Soft start .....	138
Alarm function .....	139
Sequence function .....	139
Other functions .....	140
Common specifications .....	141
General specifications .....	143
External dimensions .....	144

## Appendix

Selecting the Load Cables .....	146
Methods to Stabilize Operation .....	148
Reducing the load cable inductance .....	148
Optimizing the response speed .....	149
Using remote sensing .....	149
Slew Rate for Small Currents .....	150
Operating Area .....	151
Basic operation modes .....	151
Operation of the constant current (CC) mode .....	152
Operation in constant resistance (CR) mode .....	153
Constant power (CP) mode operation .....	155
Constant voltage (CV) mode operation .....	156
Operating area of each model .....	158
Response time .....	159
Waveform .....	160
Propagation Delay for External Control .....	161
Operating Range during Parallel Operation .....	162
Options .....	163
Parallel operation signal cable kit (PC02-PLZ-5W) .....	163

# Component Names

## Front panel

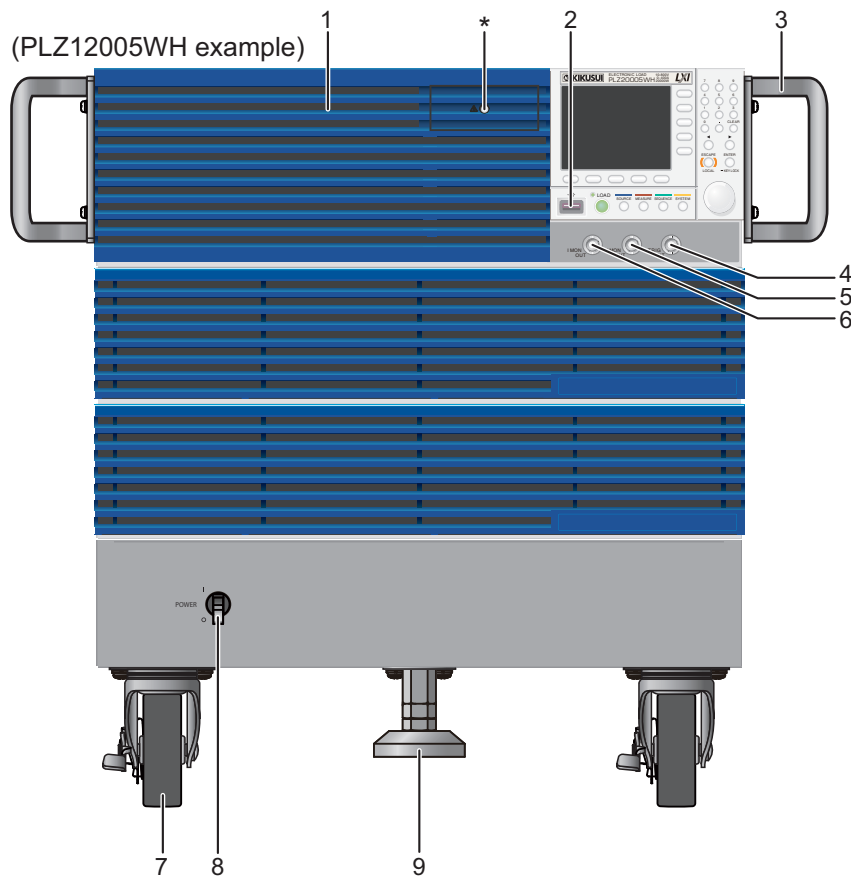

No.	Name	Function	See
1	Air inlet	Inlet holes for cooling.*	—
2	USB port (host)	This port is used to connect an external keyboard, save measurement data, save and load setup memory, save and load programs, and update the firm-ware.	<a href="#">p.20</a> <a href="#">p.56</a> <a href="#">p.71</a> <a href="#">p.97</a> <a href="#">p.131</a>
3	Handle	Left and right.	—
4	TRIG OUT terminal	Trigger signal output.	<a href="#">p.108</a>
5	V MON OUT connector	Voltage monitor output.	<a href="#">p.110</a>
6	I MON OUT connector	Current monitor output.	
7	Caster and caster lock	Push the caster lock down firmly until it stays in the ON position.	<a href="#">p.4</a>
8	POWER switch	Flip the lever up to the ( I ) side to turn the power on and down to the ( O ) side to turn it off.	<a href="#">p.13</a>
9	Stopper	Use to fix the product in the installation place.	<a href="#">p.4</a>

\* Do not remove the screw.



## Controls

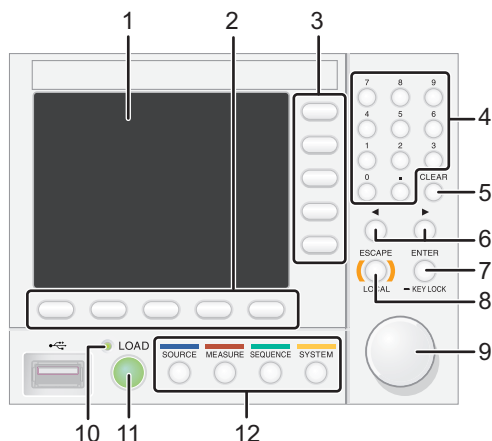

No.	Name	Function	See
1	Display	Displays the settings, measured values, and other information.	<a href="#">p.10</a>
2	Function keys	Each function key executes the item that is displayed above that key (function area).	<a href="#">p.18</a>
3	Sub-function keys	Each sub-function key executes the item that is displayed to the left of that key (sub-function area).	<a href="#">p.18</a>
4	Numeric keypad	Enters values.	<a href="#">p.20</a>
5	CLEAR key	Deletes numbers/characters.	<a href="#">p.20</a>
6	◀▶ keys	Move the cursor left and right. Select the left or right item.	<a href="#">p.20</a>
7	ENTER key KEYLOCK key	Confirms the input value when performing numeric keypad input. Confirmation after selection of setting item. Hold down to lock the keys.	<a href="#">p.20</a> <a href="#">p.119</a>
8	ESCAPE key LOCAL key	Cancels numeric/character input. Closes the window. Returns remote control to panel operation.	<a href="#">p.20</a> <a href="#">p.79</a>
9	Rotary knob	Selects items. Inputs numbers/characters.	<a href="#">p.20</a>
10	LOAD LED	Lit when the load is on.	<a href="#">p.22</a>
11	LOAD key	Turns the load on and off.	<a href="#">p.22</a>
12	Menu keys	Switches the display.	<a href="#">p.17</a>
	SOURCE key	Operation modes, current/resistance/power/voltage value setting, resistance range, sine function, pulse function, slew rate, alarm, response speed, soft start, cutoff function, external control, ABC preset memories, load on/off synchronization.	—
	MEASURE key	Measurement function, measurement trigger function, integrated data display, measurement data saving.	—
	SEQUENCE key	Sequence creating, executing, and saving. Sequence start trigger function.	<a href="#">p.80</a>
	SYSTEM key	Remote sensing, system settings, interface settings, setup memory, SCPI error display, date setting, restore factory default setting, update, device information display.	<a href="#">p.116</a>

## Display

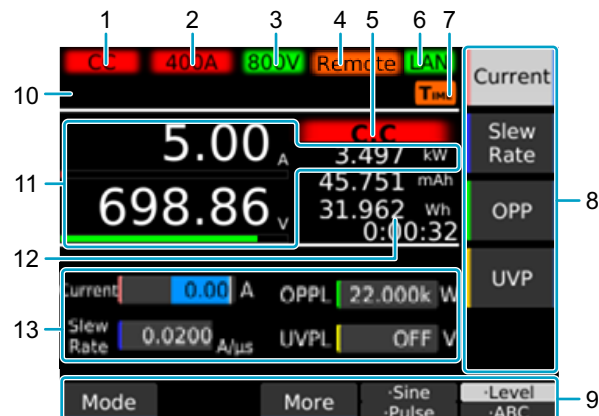

No.	Name	Function	See
1	Selected operation mode.	Displays the selected operation mode.	<a href="#">p.23</a>
2	Current range	Displays the current range (1 range). Changes to pink color when L range of CR mode is specified.	—
3	Voltage range	Displays the voltage range (1 range).	—
4	Remote	Indicates that the product is being controlled remotely.	<a href="#">p.79</a>
5	Operation mode in use	Displays the currently running operation mode.	<a href="#">p.23</a>
6	LAN	Displays the status of the LAN connection. Green: Communication enabled. Orange: Preparing for communication. Red: Not connected.	—
7	Icons	—	
		Indicates that the pulse function is running.	<a href="#">p.36</a>
		Indicates that the sine function is running.	<a href="#">p.39</a>
		Indicates that measured values are being recorded.	<a href="#">p.47</a>
		Indicates that the cutoff function is enabled.	<a href="#">p.62</a>
		Cutoff cause: Elapsed time activation, voltage drop activation	
		Cutoff cause: Integrated current activation, integrated power activation	
		Indicates that remote sensing is in progress.	<a href="#">p.59</a>
		Indicates that key lock is on. The key lock level is displayed numerically.	<a href="#">p.119</a>
		Indicates that a sequence is running.	<a href="#">p.94</a>
		External contact state and input logic setting (load on/off control).	<a href="#">p.106</a>
		Indicates that an SCPI error has occurred. The number of error incidents (up to 16) is displayed numerically.	<a href="#">p.125</a>
8	Sub-function area	Indicates that execution is possible with the keys (sub-function keys) in the right side of the display.	<a href="#">p.18</a>
9	Function area	Indicates that execution is possible with the keys (function keys) at the bottom of the display.	<a href="#">p.18</a>
10	Message area	Displays alarm messages.	<a href="#">p.40</a>
11	Measured values	Displays the current, voltage, and power values. The load input ratio for each rating is displayed in bar graph form under the current value and voltage value.	—
12	Integrated data	Displays the integrated data when integrated data display is enabled.	<a href="#">p.55</a>
13	Value	Displays load values (current, conductance, voltage, power) and other settings such as slew rate and alarm operating conditions.	—

## Rear panel

(PLZ12005WH example)

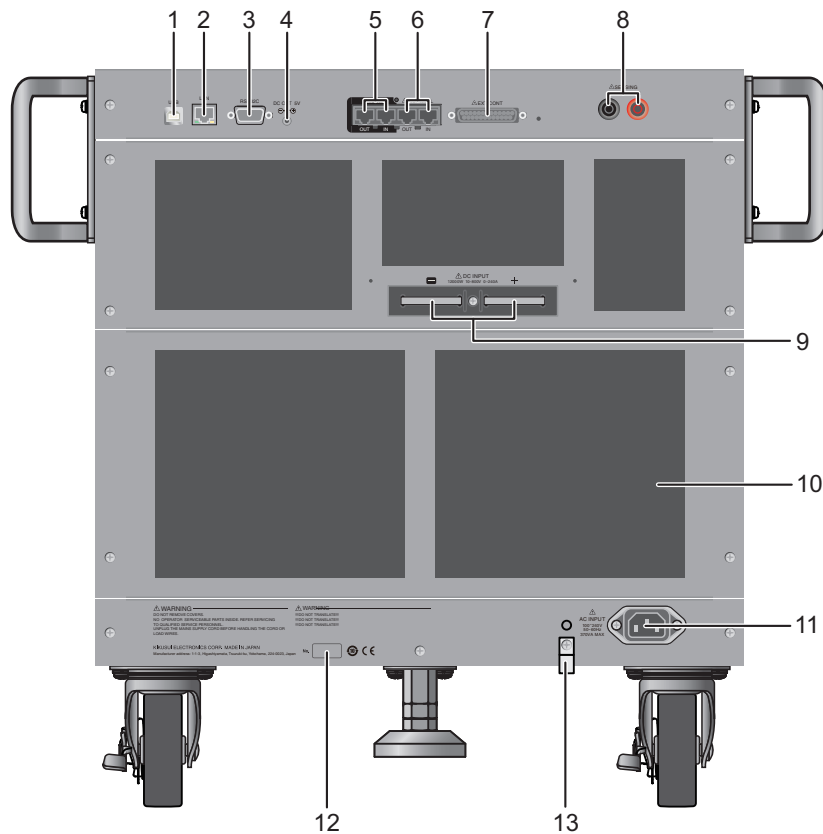

No.	Name	Function	See
1	USB port (device)	USB port for remote control.	
2	LAN port	LAN port for remote control.	Interface Manual
3	RS232C port	RS232C port for remote control.	Manual
4	DC OUT connector	Used during GPIB converter (option) use.	<a href="#">p.164</a>
5	EXT SYNC port	Connector for synchronized operation. A cover for the pins is provided.	<a href="#">p.74</a>
6	PARALLEL connector	Connector for parallel operation. A cover for the pins is provided.	<a href="#">p.112</a>
7	EXT CONT connector	External control connector. A cover for the pins is provided.	<a href="#">p.99</a>
8	SENSING terminal	Remote sensing connector.	<a href="#">p.59</a>
9	DC INPUT terminal (load input terminal)	Used to connect the DUT and the product.	<a href="#">p.14</a>
10	Air outlet	Air outlet for cooling.	—
11	AC INPUT connector	Power inlet.	<a href="#">p.12</a>
12	Serial number	The product's serial number.	—
13	Cord anchor	Used to hold the power cord in place.	—

# Installation

## Connecting the Power Cord



**WARNING** Risk of electric shock.

- This product conforms to IEC Safety Class I (equipment that has a protective conductor terminal). Be sure to earth ground the product to prevent electric shock.
- The product is grounded through the power cord ground wire. Connect the protective conductor terminal to earth ground.

### NOTE

- Use the supplied power cord to connect to the AC line. If the supplied power cord cannot be used because the rated voltage or the plug shape is incompatible, have a qualified engineer replace it with an appropriate power cord that is 3 m or less in length. If obtaining a power cord is difficult, contact your Kikusui agent or distributor.
- The power cord with a plug can be used to disconnect the product from the AC power line in an emergency.
- Secure adequate space around the power plug. Do not insert the power plug to an outlet where accessibility to the plug is poor. And, do not place objects near the outlet that would result in poor accessibility to the plug.
- Do not use the supplied power cord with other instruments.

This product conforms to IEC Overvoltage Category II (energy-consuming equipment that is supplied from a fixed installation).

**1** Turn the **POWER** switch off (O).

**2** Check that the **AC power line meets the nominal input rating of the product.**

The product can receive a nominal line voltage in the range of 100 Vac to 240 Vac at 50 Hz or 60 Hz. (Frequency range: 47 Hz to 63 Hz)

**3** Connect the power cord to the **AC INPUT** inlet on the rear panel.

If necessary, secure the power cord with the cord anchor.

**4** Connect the power cord plug to an outlet with a ground terminal.

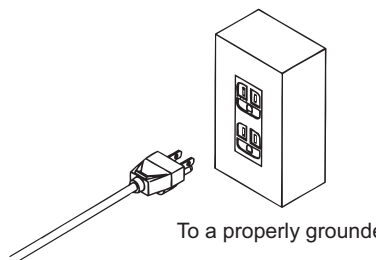

This completes the setting.

# Turning the Power On or Off

## Turning the power on

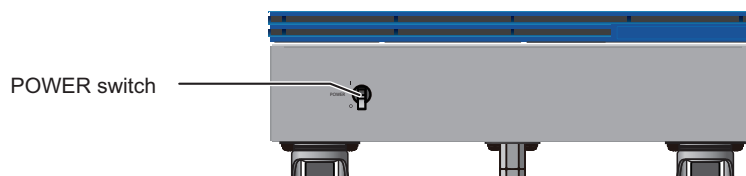

- 1** Check that the power cord is connected correctly.
- 2** Check that nothing is connected to the DC INPUT (load input) terminals.
- 3** Turn the POWER switch on (I).  
The power turns on, and the display lights.

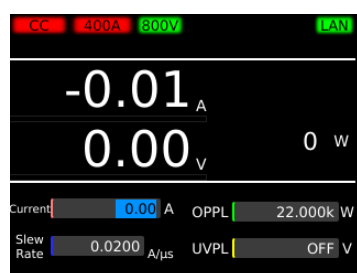

If you notice strange sounds, unusual odors, fire, or smoke around or from inside the product, flip the POWER switch off, or remove the power cord plug from the outlet.

By factory default, the panel settings immediately before the POWER switch is turned off are saved. When you turn the power on, the PLZ12005WH/PLZ20005WH starts in the same state as it was in the last time it was turned off (p.129). (However, the load setting is always Load Off.)

The panel setting state at startup can be changed (p.117).

### NOTE

- The POWER switch of this product is a circuit breaker type. If there is an error in the internal power supply of this product, the POWER switch is activated as a power supply circuit breaker.
- Before turning on the POWER switch again, check whether the AC power line is compatible with the input rating of this product.
- If the power-up operation is unstable even when the AC power line is compatible with the input rating of this product, stop using the product immediately, and remove the power cord plug from the outlet.

## Turning the power off

Lower the POWER switch lever to the O side to turn the power off.

### CAUTION

If you want to turn the POWER switch back on, wait at least 5 seconds after the fan stops. Repeatedly turning the POWER switch on and off at short intervals will shorten the service life of the POWER switch and the internal input fuse.

# Connecting to the DUT

For information on selecting load cables, refer to “Selecting the Load Cables” (p. 146) in the “Appendix”. Large current load cables are available as options.

## ⚠ WARNING

**Risk of electric shock.**

- Do not touch load input terminals when the output is turned on.
- Do not approach or place non-isolated objects within 5 cm of the load cables when the output is turned on.

## ⚠ CAUTION

**Risk of damage.**

- Do not connect the DUT to the load input terminals while the product's load is turned on.
- Do not invert the polarity when connecting. An overcurrent might flow regardless of whether the load is turned on.

To avoid overheating, observe the following precaution.

- Use the supplied screws to connect the cables with crimping terminals.

## Connecting to the load input terminals

Connect the DUT to the load input terminals on the rear panel.

## ⚠ WARNING

**Risk of electric shock. Be sure to attach the cover for the load input terminals.**

- 1 Turn the load off.**
- 2 Turn off the output of the DUT.**
- 3 Attach crimping terminals to the load cables.**

The load input terminals have bolt (M12) holes for connecting the load cables. Attach the appropriate crimping terminals to the cables.

- 4 Connect the load cables to the load input terminals using the included load input terminal screw set.**

The connections when there are two load cables and when there are four cables are shown. Tightening torque: 33.06 N•m

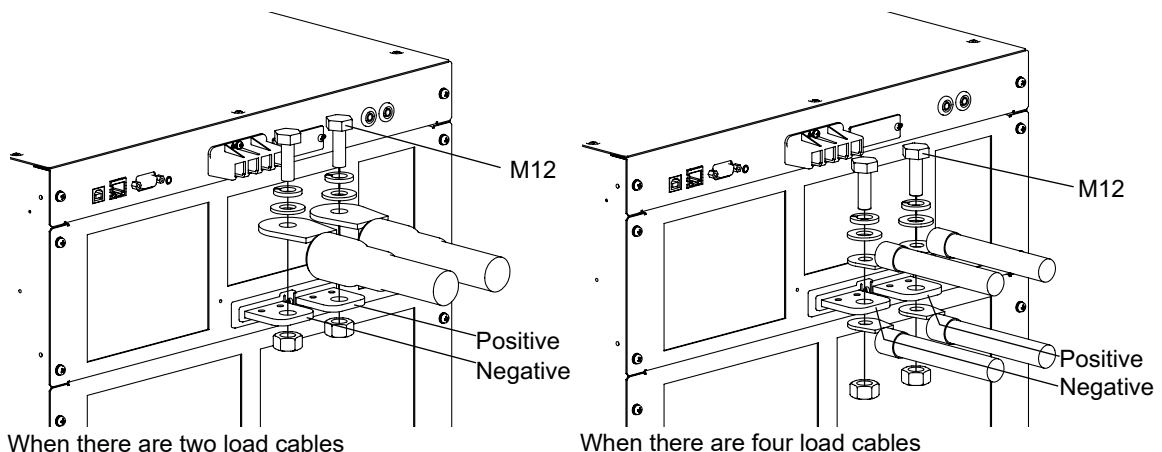

- 5** Place the bottom half of the load input terminal cover underneath the cables connected to the load input terminals.

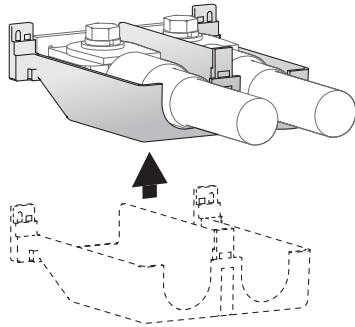

- 6** Align the top half of the load input terminal cover to the bottom half.  
Align the tabs of the load input terminal cover according to the load cable diameter.

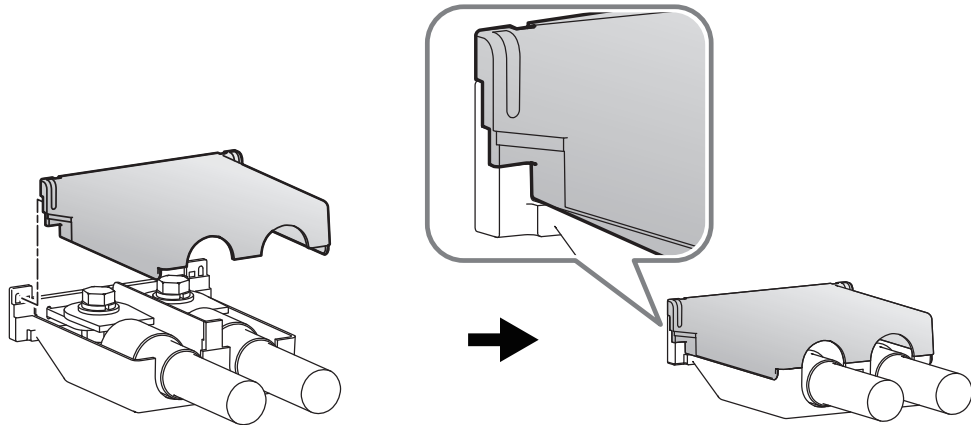

- 7** Push the load input terminal cover against the panel, and fasten it with the included load input terminal cover screws.

Make sure that the screws are securely fastened.

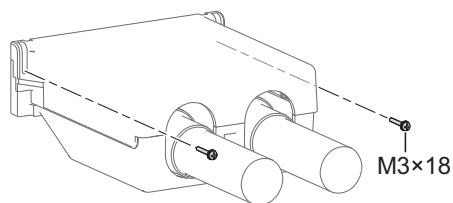

- 8** Connect the load cables to the output terminals of the DUT.

Be careful to match the polarities of the load input terminals with those of the DUT terminals during connection.

Use the shortest cables possible to connect the product and DUT, and twist the cables. If the cables are too thick to be twisted, bring the load input terminal's positive and negative terminal cables close together and make them parallel.

This completes the connections.

## Notes regarding load input terminals

### Do not apply overvoltage to the load input terminals

**CAUTION** Risk of damage. Do not apply a voltage that exceeds 800 Vdc to the load input terminals.

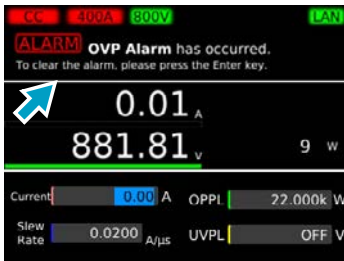
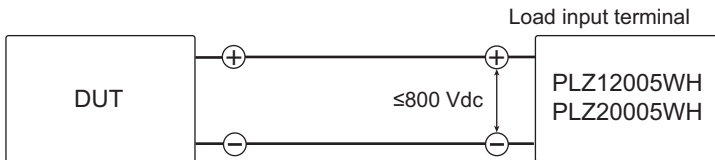

If a voltage exceeding 880 V is applied to the load input terminals, a beeping sound is generated and an OVP alarm (overvoltage detection) appears.

If this happens, immediately lower the voltage of the DUT.

### Match the wiring polarity with that of the DUT

**CAUTION** Risk of damage. Be careful to match the polarities of the load input terminals with those of the DUT during connection.

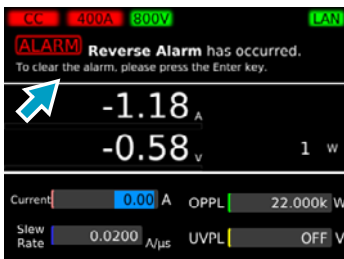
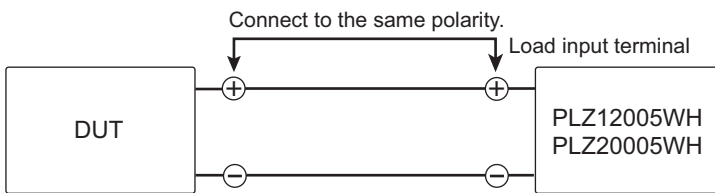

If a reverse voltage of -5 V or higher is applied or a reverse current (approximately -1 % of the rating) flows, a beeping sound is generated and a reverse alarm (reverse-connection detection) appears.

If this happens, immediately shut off the DUT output.



# Basic Functions

## Panel Operations

This chapter explains the front panel operations in general.

### Switching the display

There are two display modes: function display and main display. The function display shows functions that can be executed on each screen. The main display shows measured values with large numbers.

Pressing a menu key shows the function display of the corresponding menu screen. Pressing the same menu key again on the function display switches the display to the main display.

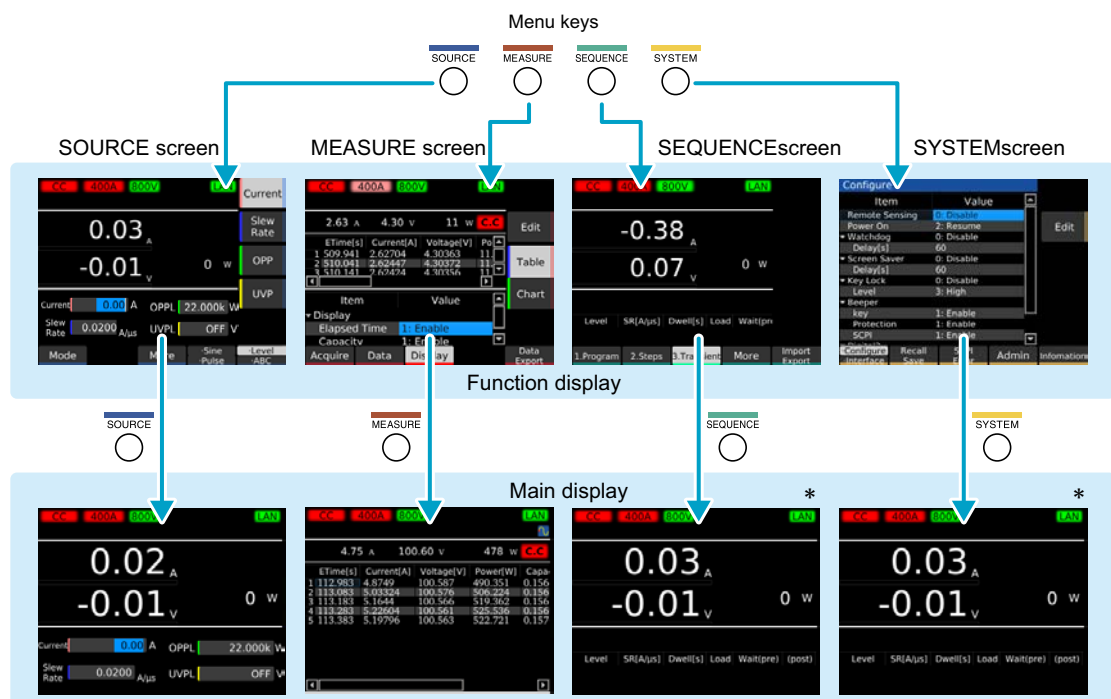

\* On the SEQUENCE screen, the main display of the screen that appears when 3.Transient is pressed appears. On the SYSTEM screen, the main display of the menu screen displayed previously appears.

Menu keys	Main functions			
SOURCE	Operation mode and load setting	Resistance range	Slew rate	Pulse
	Sine	Alarm	Response speed	Soft start
	Cutoff	ABC preset memories	Load on/off synchronization	External control
MEASURE	Measurement recording	Measurement recording trigger	Integrated data recording, display	Measurement recording synchronization
	Sequence function	Program configuration	Step configuration	Sequence execution
SYSTEM	Sequence synchronization	Sequence start trigger		
	Remote sensing	Setup memory	System configuration	Interface setting
	SCPI error display	Date/time setting	Factory default settings	Resets settings
	Display of device information	Updating		

## Using the function keys

On the function display (p.17), the available functions are shown in the function area and sub-function area. You can execute or select the functions by pressing the corresponding function key or sub-function key. The selected function is shown with a light gray background.

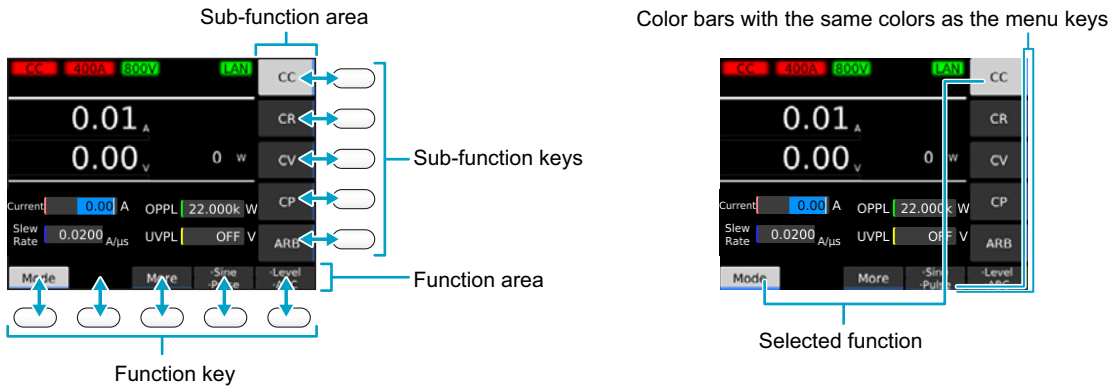

## When several functions are shown

If several functions that can be used with a single function key are shown, you can toggle between the functions by repeatedly pressing the function key.

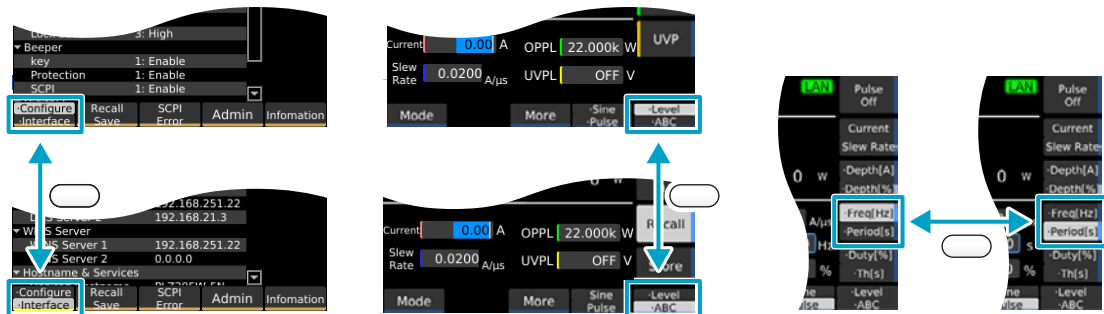

## Key names

In this document, individual function keys and sub-function keys are distinguished by indicating the function names shown in the function area or sub-function area as the key names. If there are several functions shown, the name of the function to use is indicated as the key name.

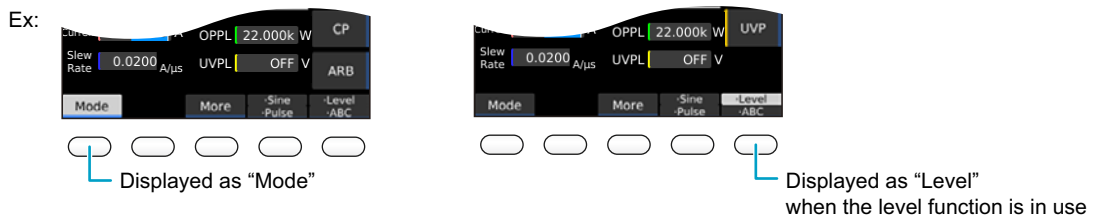

## Selecting items based on color markers

### For menus



Color markers corresponding to the colors of menu keys are shown at the bottom edge of the function area and at the right edge of the sub-function area. The color marker makes it possible to identify the present menu screen.

### For settings

In the function display of the SOURCE screen, color markers appear at the left edge for the items in the sub-function area. These marker colors correspond to those at the left edge of the value input area.

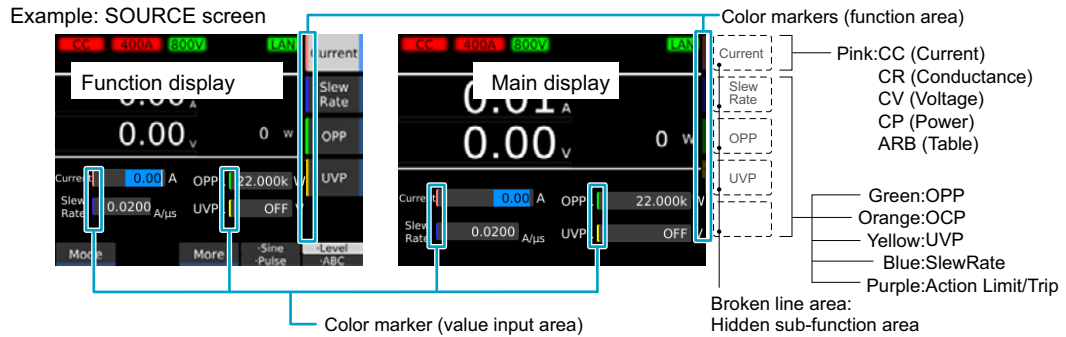

The color markers that appear at the right edge of the main display represent hidden sub-function area items. You can identify the sub-function keys without switching to the function display, so it saves you from pressing the key.

- In the main display of the SOURCE screen, you can press sub-function keys that are the same colors as the color markers in the value input area.
- On the MEASURE and SEQUENCE screens, you can press sub-function keys that are the same colors as the items on the function display.

## Operation example (Selection of constant resistance mode)

**1** Press SOURCE, Mode, and then CR.

In the above step example, press the buttons in the following order.

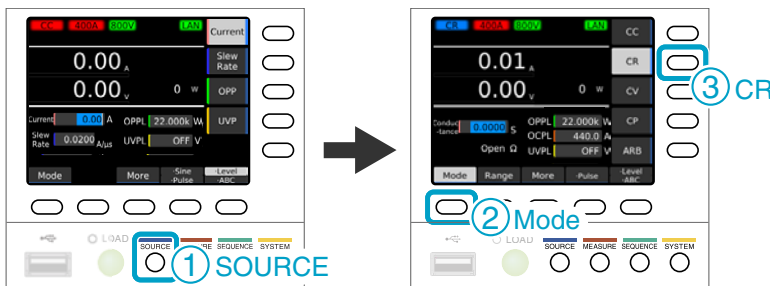

## Inputting numbers and characters

You can enter numbers and characters in input areas from the front panel or external keyboard. Numeric input and character input switch automatically according to the input area.

If numbers or characters are selected in an input area, they can be changed. If only a cursor is shown in an input area, you can enter characters or numbers at the cursor position.

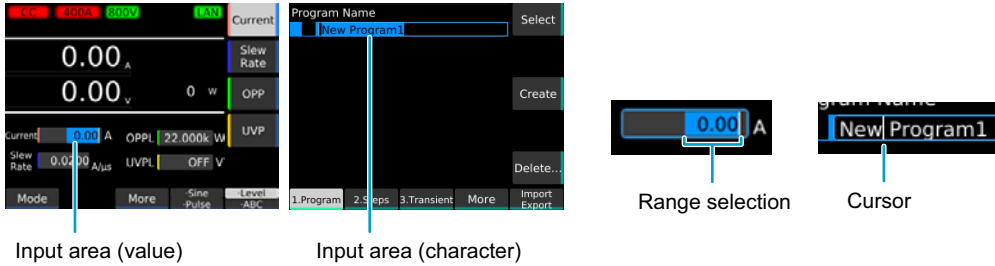

### Entering from the front panel

Purpose	Operation	Description
Numeric input <sup>1</sup>	Numeric keypad	You can enter numbers and a decimal point. Following input, press the ENTER key to confirm the value.
	Rotary knob	You can enter numbers. Turn clockwise to increase the value and counterclockwise to decrease. The value is confirmed immediately upon input.
Character input	numeric keypad	You can enter numbers and dots.
	Rotary knob	Turn clockwise to enter characters in the following order: space, uppercase letters, lowercase letters, numbers, and symbols. Turn counterclockwise to enter character in reverse order. To enter the next character, press the ◀▶ key to move the cursor. The character entered immediately before is confirmed when you press the ◀▶ key.
Cursor movement	◀▶ keys	Changes the number of digits or input position.
Delete	CLEAR key	Deletes the number or character on the left of the cursor or the selected range.
Cancel	ESCAPE key	Cancels numeric/character input.

1. Numeric input such as current and voltage has input limits based on the setting range and other conditions. You cannot enter numbers outside the input range. For details on the setting ranges, see “Specifications” (p.134).

### Entering from an external keyboard

You can enter numbers/characters if you connect a keyboard to the USB port on the front panel. Use the arrow keys to move the cursor, the Backspace and Delete key to delete numbers and characters, the Escape key to cancel input, the Enter key to confirm, and the Tab key to move between input items. You can connect the keyboard while the product is turned on.

The types of keyboards that you can use are 101-key and 104-key keyboards.

## Changing values

To change a selected value (e.g., load value), use the numeric keypad or rotary knob. If you enter a value with the numeric keypad, following input, press the ENTER key to confirm the value.

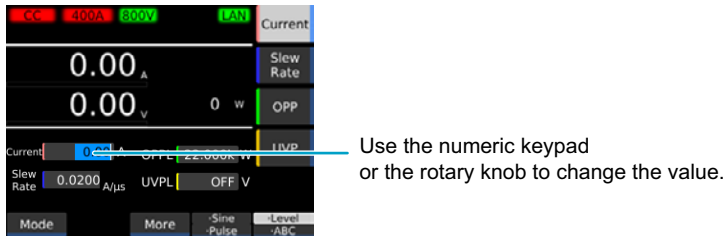

On screens in which “Edit” is shown in the sub-function area, use the rotary knob to select the item you want to change, and then press the Edit key or a numeric key to start changing the value. Procedures using the Edit key are provided in this document.

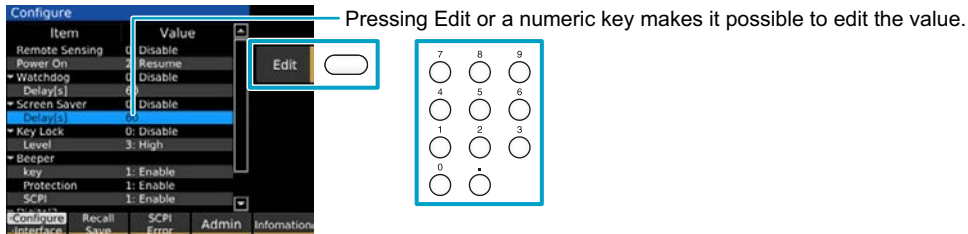

When changing a setting, if there are multiple items you can choose from, select a number in front of the item name using the numeric keypad, or select the item using the rotary knob. Procedures using the rotary knob are provided in this document.

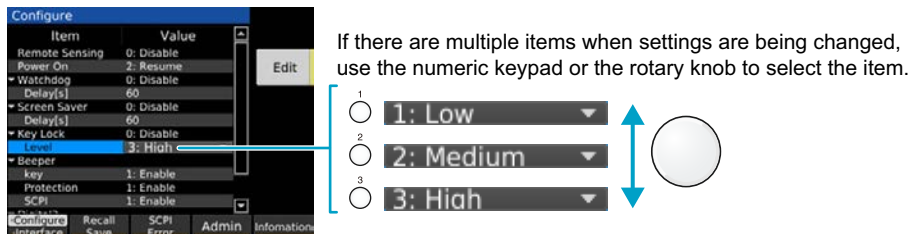

To confirm a value you entered, press the Edit or ENTER key. Procedures using the ENTER key are provided in this document.

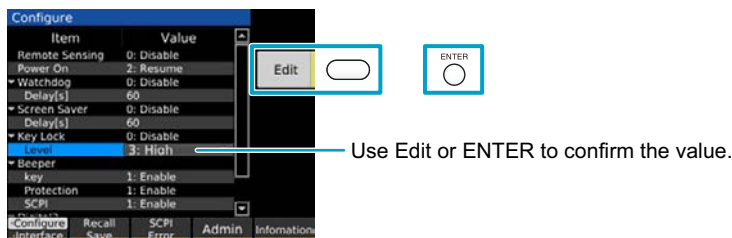

# Load On/Off

The phrase “load on” refers to a condition in which a current is running through the product. “Turning the load on” refers to the operation of running a current through the product. Conversely, “load off” refers to a condition in which a current is not running through the product. “Turning the load off” refers to the operation of stopping a current from running through the product. You can turn the product’s load on and off using the LOAD key.

## 1 Press LOAD.

The value switches between load on and load off each time you press LOAD.

In the load on state, the load on LED lights.

In the load off state, the load on LED turns off.

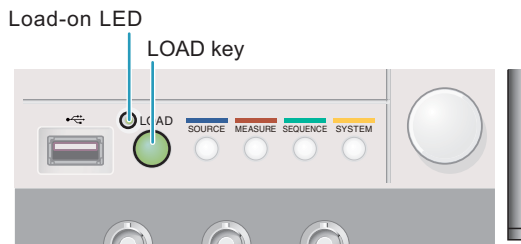

### ■ Controlling load on/load off externally

Load on/load off can be controlled using an external signal ([p. 105](#)).

### ■ Gradually raising the input current

In constant current (CC) mode, you can set to slowly increase the input current (Soft start) ([p. 58](#)).

### ■ Turning off the load after a specified time elapses

When performing battery or capacitor discharge tests, it is convenient to use the function that turns off the load when a specified time elapses (cutoff function) ([p. 62](#)).

### ■ Turning off the load by specifying conditions

The load can be turned off when the voltage drop, the integrated current, or the integrated power reaches the specified value ([p. 62](#)).

# Setting the Operation Mode

The product has the following five operation modes. Mode switching can be done only while the load is off.

Constant current (CC) mode	When a current value is specified, the current is kept at that value even when the voltage changes.
Constant resistance (CR) mode	When a conductance value is specified, the product sinks current proportional to the voltage variation by using the value as a proportionality constant.
Constant voltage (CV) mode	When a voltage value is specified, the product runs the current so that the voltage is kept at that value.
Constant power (CP) mode	When a power value is specified, the product runs the current so that the power is kept at that value.
Arbitrary I-V Characteristics (ARB) Mode	By setting multiple voltage and current values, you can set load characteristics that have multiple voltage and current points. The desired load characteristics can be set by specifying multiple arbitrary voltage values and current values as I-V characteristics.

## Setting the Operation Mode

You can set the operation mode only when the load is off.

### 1 Press SOURCE and then Mode.

The operation mode is shown in the sub-function area.

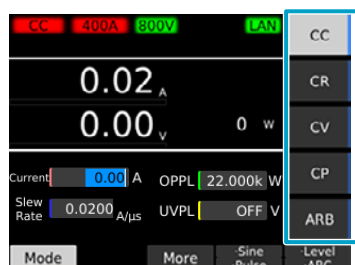

### 2 Use the sub-function keys to select the operation mode.

“CC” (red), “CR” (blue), “CV” (green), “CP” (orange), or “ARB” (gray) appears in the upper left of the display depending on the selected operation mode.

This completes the setting.

## Setting the current in CC mode

In CC mode, the current is kept constant even when the voltage changes.

For details on CC mode, see “Operation of the constant current (CC) mode” (p.152).

**1** Set the operation mode to CC mode (p.23).

**2** Press Level and then Current.



**3** Use the numeric keypad or the rotary knob to enter the current value.

This completes the setting. The current value can be changed even while the load is turned on.

### Adding the +CV mode (using the SCPI command)

You cannot set the +CV mode from the front panel, but you can do so by using an SCPI command for the CC and CR modes. If set, CC+CV or CR+CV appears in the “selected operation mode” area (p.10) at the top of the display. This function is available for compatibility with the SCPI command of the PLZ-5W series (PLZ205W, PLZ405W, PLZ1205W).



## Setting the conductance in CR mode

In CR mode, the product sinks current proportional to the voltage variation. The displayed resistance is a value converted from the conductance. An appropriate SI prefix (k: kilo, m: milli) is displayed according to the converted resistance, and up to three decimal digits are displayed. (Conductance [S] = 1/resistance [ $\Omega$ ]) For details on CR mode, see “Operation in constant resistance (CR) mode” (p.153).

**1** Set the operation mode to CR mode (p.23).

**2** Press Level and then Conductance.



**3** Use the numeric keypad or the rotary knob to enter the conductance value.



Resistances are displayed with k for kilo or m for milli.  
Up to three decimal places are displayed.

The conductance value can be changed even while the load is turned on.  
This completes the setting.

## Adding the +CV mode (a function compatible with the PLZ-5W series)

If you want to set the +CV mode, which is available on the PLZ-5W series (PLZ205W, PLZ405W, PLZ1205W), on this product, use an SCPI command. The +CV mode can be specified in CC mode or CR mode. If you set the +CV mode, CC+CV or CR+CV appears in the “selected operation mode” area (p.10) in the upper left of the display.

This function is available for maintaining compatibility with the SCPI commands of the PLZ-5W series. For details on SCPI commands, see the Communication Interface Manual on the included CD-ROM.

## Setting the resistance range of CR mode

In CR mode, you can select H or L for the resistance range. The resistance range is used to set the conductance with the appropriate resolution. The current range is fixed. You can set the resistance range when the load is off.

**1 Press SOURCE and then Range.**

**2 Set the resistance range to H or L.**

The H range is used for conductance whose current variation is large relative to the voltage variation. Otherwise, the L range is used. When the L range is used, the current range display changes from red to pink.

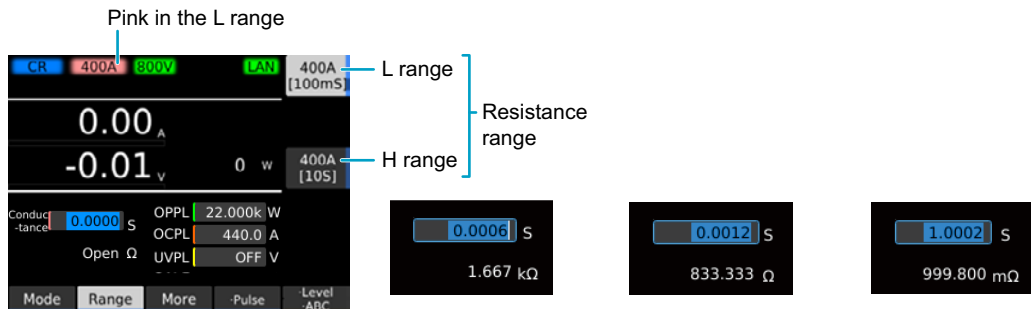

PLZ20005WH example

Displays k for kilo or m for milli and displays up to three decimal

Resistance range	Parameter	PLZ12005WH	PLZ20005WH
H range	Setting range	6060.0 mS to 0 S	10.1000 S to 0 S
	Resolution	0.2 mS	0.2 mS
L range	Setting range	60.600 mS to 0 S	101.000 mS to 0 S
	Resolution	0.002 mS	0.002 mS

## Setting the voltage in CV mode

In CV mode, the product runs current so that the voltage at the load input end of the product is constant. For details on CV mode, see “Constant voltage (CV) mode operation” (p.156).

**1** Set the operation mode to CV mode (p.23).

**2** Press Level and then Voltage.



**3** Use the numeric keypad or the rotary knob to enter the voltage value.

This completes the setting. The voltage value can be changed even while the load is turned on.

## Setting the power in CP mode

In CP mode, the product runs current so that the consumed power is constant.  
For details on CP mode, see “Constant voltage (CV) mode operation” (p.156).

**1** Set the operation mode to CP mode (p.23).

**2** Press Level and then Power.



**3** Use the numeric keypad or the rotary knob to enter the power value.

This completes the setting. The power value can be changed even while the load is turned on.

## Setting the I-V characteristics in ARB mode

In ARB mode, arbitrary I-V characteristics can be set by registering multiple I-V characteristic points (pairs of voltage and current values). Three up to 100 points can be registered, and the space between two points is linearly interpolated. The minimum voltage (0.00 V) and current (0.00 A) and the maximum voltage (808.00 V) are fixed. This mode can be used for simulation of LED loads and the like.

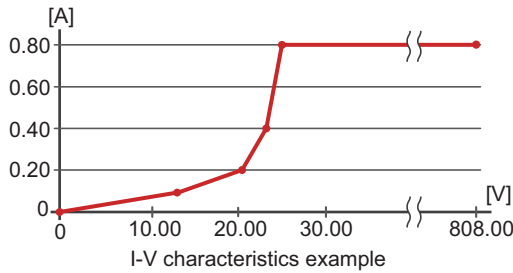

Example of settings (values with an asterisk are fixed)

Voltage [V]	Current [A]
0.00*	0.00*
12.00	0.10
20.50	0.20
23.00	0.40
24.50	0.80
808.00*	0.80

### Displaying the I-V characteristics editing screen

**1** Set the operation mode to ARB mode (p.23).

**2** Press Level and then Table.

The I-V characteristics editing screen appears.



### Basic operations on the I-V characteristics editing screen

The left column is voltage, and the right is current. In each row, you can enter a single point of your choice.

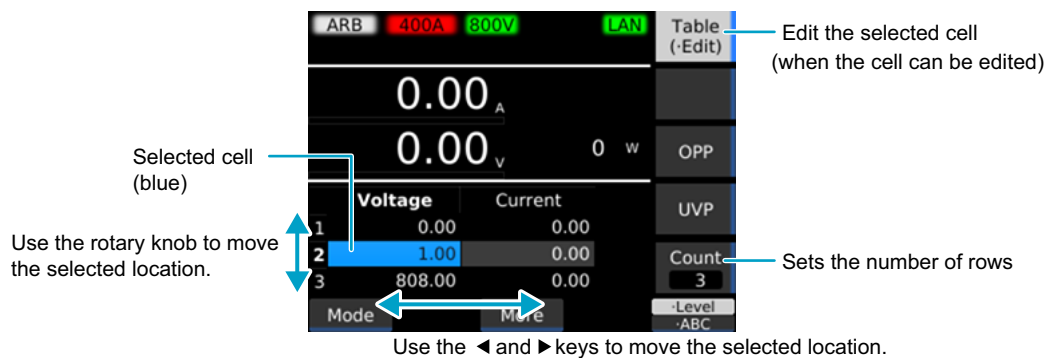

## Setting the number of rows

- You can change the total number of rows (Count 3 to Count 100) using the Count key.
- Increase the number of rows: A copy of the selected row is inserted after the selected row.
- Decrease the number of rows: If you set the total number of rows less than the number of the selected row, the last rows excluding the very last row are deleted.  
If you set the total number of rows larger than the number of the selected row, the selected row and subsequent rows are deleted.

Selecting row 3 and changing Count from 5 to 7

	Voltage	Current
1	0.00	0.00
2	1.00	0.10
3	2.00	0.20
4	3.00	0.30
5	808.00	0.40

← Two rows are inserted with the copy of row 3.



	Voltage	Current
1	0.00	0.00
2	1.00	0.10
3	2.00	0.20
4	2.00	0.20
5	2.00	0.20
6	3.00	0.30
7	808.00	0.40

Selecting row 4 and changing Count from 7 to 3

	Voltage	Current
1	0.00	0.00
2	1.00	0.10
3	2.00	0.20
4	3.00	0.30
5	4.00	0.40
6	5.00	0.50
7	808.00	0.60

Deleted



	Voltage	Current
1	0.00	0.00
2	1.00	0.10
3	808.00	0.60

Selecting row 4 and changing Count from 7 to 5

	Voltage	Current
1	0.00	0.00
2	1.00	0.10
3	2.00	0.20
4	3.00	0.30
5	4.00	0.40
6	5.00	0.50
7	808.00	0.60

Deleted



	Voltage	Current
1	0.00	0.00
2	1.00	0.10
3	2.00	0.20
4	5.00	0.50
5	808.00	0.60

- 1 Press Count.**
- 2 Use the numeric keypad or the rotary knob to enter the number of rows, and then press ENTER.**

This completes the setting.

## Setting the frequency

- The voltage (0.00 V) and current (0.00 A) in the first row and the voltage (808.00 V) in the last row are fixed.
- Set the voltages to linearly increasing values as the line number increases. Same values are considered an increase. You cannot enter a voltage that is less than the previous row or a voltage that is greater than the next row.

- 1 Select a value with the rotary knob and ◀▶ keys.**
- 2 Press Table (Edit).**
- 3 Use the numeric keypad or the rotary knob to enter a value, and then press ENTER.**

This completes the setting.

## Example of setting I-V characteristics (steps 1 to 13)

You can smoothly set the I-V characteristics by first setting the number of rows and then setting the row with the maximum voltage and proceeding to rows with lower voltages. As an example, let's set the I-V characteristics while referring to the table below.

Example of settings  
(values with an asterisk are fixed)

Count	Voltage [V]	Current [A]
1	0.00*	0.00*
2	12.00	0.10
3	20.50	0.20
4	23.00	0.40
5	24.50	0.80
6	808.00*	0.80

### 1 Press Level and then Table.

The I-V characteristics editing screen appears.



### ■ Setting the count value

### 2 Press Count.

### 3 Use the numeric keypad or the rotary knob to enter the number of rows "6", and then press ENTER.

The rows are added.

### ■ Setting the current value of row 6

Set only the current value because the voltage is fixed to the maximum voltage (808.00 V).

### 4 Use the rotary knob and the ► key to select the Current column of row 6.

### 5 Press Table (Edit).

The current value in row 6 becomes editable.

### 6 Use the numeric keypad or the rotary knob to enter the current value "0.8", and then press ENTER.

The current value in row 6 is set to 0.8 A.



■Setting the voltage value of row 5

**7** Use the rotary knob and the ◀ key to select the Voltage column of the row 5.



**8** Press Table (Edit).

The voltage value in row 5 becomes editable.

**9** Use the numeric keypad or the rotary knob to enter the voltage value “24.5”, and then press ENTER.

The voltage value in row 5 is set to 24.5 V.

■Setting the current value of row 5

**10** Use the ▶ key to select the Current column of row 5.



**11** Press Table (Edit).

The current value in row 5 becomes editable.

**12** Use the numeric keypad or the rotary knob to enter the current value “0.8”, and then press ENTER.

The current value in row 5 is set to 0.8 A.

■Setting the rest of the rows



**13** In the same manner, set the voltage and current values in rows 4 through 2.

This completes the setting.

Characteristics display screen (example)

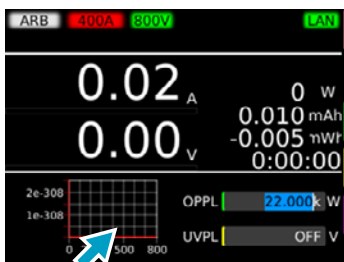



# Setting the Slew Rate

You can set the speed of change when the current is changed.

The slew rate functions in the following cases.

- When the setting is changed to change the current value (including the pulse function).
- When the current value is changed using external control in constant current (CC) mode.
- When the current value is changed while the load is on

The slew rate is set as an amount of current change per unit time. The value is common to rising and falling slopes.

## NOTE

- The specified slew rate may not be achieved depending on the load cable inductance. If this happens, reduce the load cable inductance ([p.148](#)).
- If the load current is small, the specified slew rate may not be achieved ([p.150](#)).
- If the current changes when the load is turned on, the slew rate may be slower than the setting.

You can set this regardless of whether the load is on or off. This function operates in CC and ARB modes.

**1** Switch to CC or ARB mode ([p.23](#)).

**2** Press Level, and then Slew Rate.

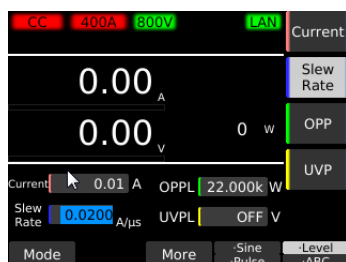

**3** Use the numeric keypad or the rotary knob to enter the slew rate value.

This completes the setting.

# Pulse Function

Pulse refers to the operation of executing two settings repetitively. It is suitable for transient response characteristics testing of large capacity power supplies and batteries. When the pulse operation is in progress, a trigger signal is output from the TRIG OUT connector on the front panel (p.36). You can set this regardless of whether the load is on or off. This function operates in CC and CR modes.

## Setting the pulse amplitude

The pulse amplitude is set with a value or a percentage of the load value.

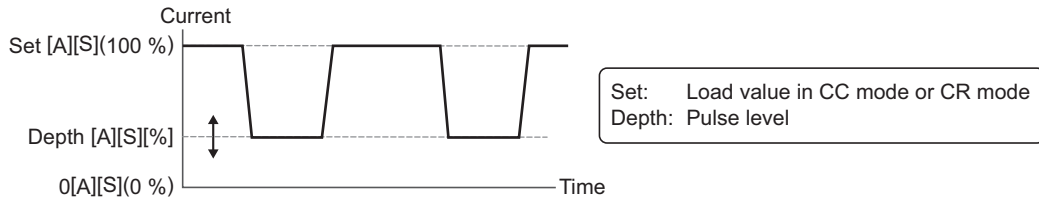

- 1 Switch to CC or ARB mode (p.23).
- 2 Press Pulse > Current or Conductance.



- 3 Use the numeric keypad or rotary knob to enter the set level (Set).  
Enter a value (current [A] for CC mode, conductance [S] for CR mode).

- 4 Press Depth.



- 5 Use the numeric keypad or the rotary knob to enter the pulse amplitude (Depth).  
Enter a value (a current [A] in CC mode or a conductance [S] in CR mode) or a percentage of the load value (Set). The input switches between numeric input and percentage [%] input every time you press Depth.  
This completes the setting.

## Setting the pulse interval

Set the pulse interval using the length of time at the high level or the duty ratio (ratio of high level to one cycle) for the frequency or cycle.

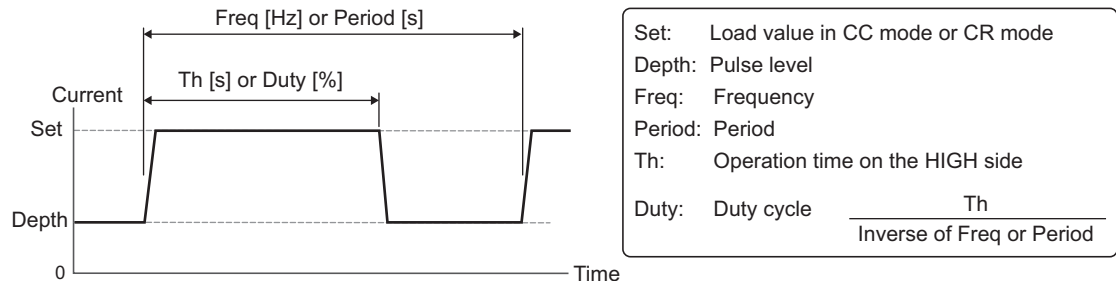

### 1 Press SOURCE > Pulse > Freq or Period.

The input switches between frequency [Hz] input and cycle [s] input every time you press the key.

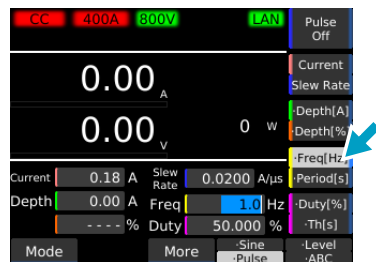

### 2 Use the rotary knob to enter the frequency (FREQ) or period.

You can enter the frequency also using the numeric keypad.

### 3 Press Duty or Th.

The input switches between duty ratio [%] input and high level time [s] input every time you press the key.

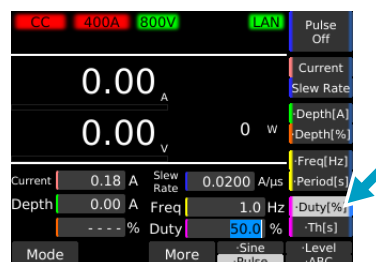

### 4 Use the rotary knob to enter the duty ratio or high level time (Th).

You can enter the duty ratio also using the numeric keypad. The minimum pulse interval is 5  $\mu\text{s}$ . The minimum changeable digit of high level time varies depending on the frequency.

This completes the setting.

## Turning the pulse function on/off

If you want to turn on the pulse function, set the pulse level (p.34) and pulse interval (p.35) in advance.

**1 Press SOURCE > Pulse.**

**2 Press Pulse On or Pulse Off.**

The pulse function toggles between on and off each time you press the key.

When the pulse function is on,  is shown on the display.



## Timing of trigger signal output

When a pulse operation is in progress, a trigger signal is output for 10 μs from the TRIG OUT connector on the front panel when the current changes from low (Depth) to high (Set) level.

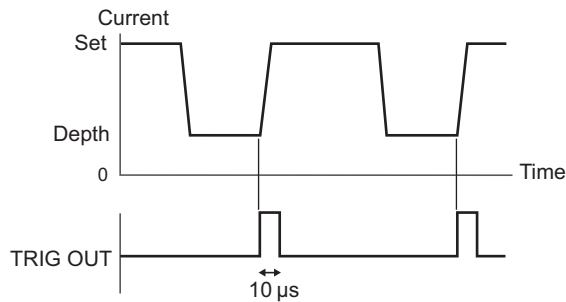

# Sine Function

The sine function varies the current sinusoidally. It is suitable for superposed ripple testing of large capacity power supplies and batteries. When a sine operation is in progress, a trigger signal is output from the TRIG OUT connector on the front panel (p.36). You can set this regardless of whether the load is on or off. This function operates in CC mode. You cannot set the slew rate.

## Setting the amplitude

Set the sine amplitude with a value.

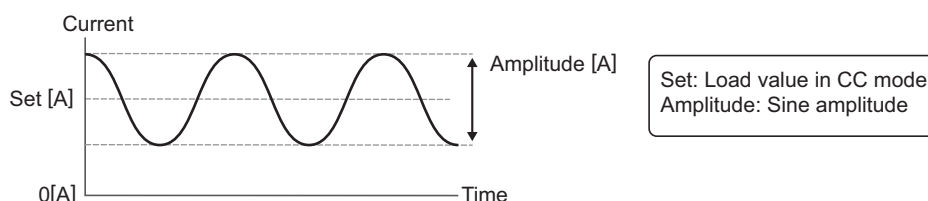

**1** Set the operation mode to CC mode (p.23).

**2** Press SOURCE > Sine > Current.

If already set, proceed to step 4.



**3** Use the numeric keypad or rotary knob to enter the set level (Set).

Enter a value (current [A] for CC mode). The set level is the center value of the amplitude.

**4** Press Amplitude.



**5** Use the numeric keypad or the rotary knob to enter the sine amplitude (Amplitude).

The amplitude is a P-P value with the center value at the set level.

This completes the setting.

### Setting example

When the amplitude is from 0 A to the rated current, setting the set level to Set1 causes a portion of the upper side of the sine wave to exceed the rated current, so the amplitude is limited by the rated current. Likewise, setting the set level to Set2 causes a portion of the lower side of the sine wave to become less than 0 A, so the amplitude is limited by 0 A.

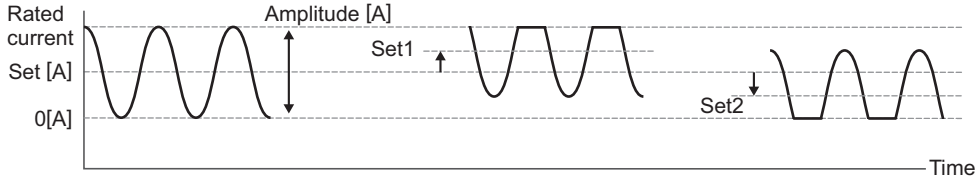

### Setting the Frequency

Set the frequency of the sine amplitude set with Amplitude.

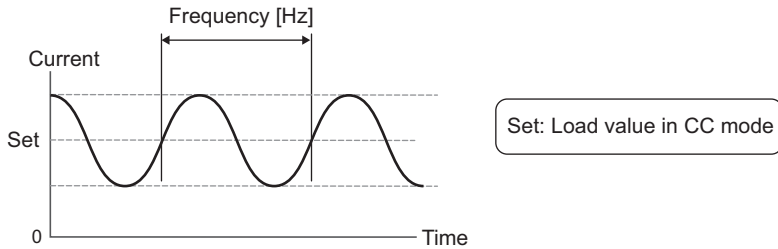

**1** Press SOURCE > Sine > Frequency.



**2** Use the numeric keypad or the rotary knob to enter the frequency (Freq).

If you are using the numeric keypad, you can only set values within the frequency setting range defined in the specifications and with the setting resolution within that range.

Example: If you try to enter 101 Hz, the “1” in the ones digit will not be accepted.

This completes the setting.

## Turning the sine function on/off

If you want to turn on the sine function, set the sine amplitude (p.34) and frequency (p.35) in advance.

**1** Press **SOURCE > Sine**.

**2** Press **Sine On or Sine Off**.

The sine function switches on and off each time you press the key.

When the sine function is on,  is shown on the display.



## Trigger signal timing

When a sine operation is in progress, a trigger signal is output for 10  $\mu$ s from the TRIG OUT connector on the front panel when the current passes through the Set value on the rising edge (sine wave phase at 0 degrees).

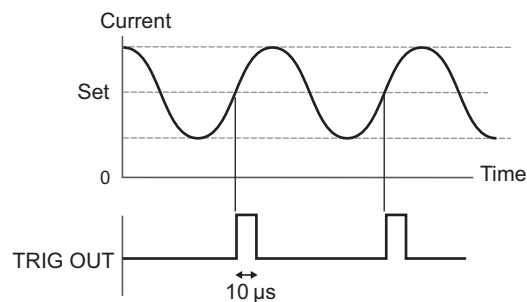

# Alarm Function

This function detects anomalies and protects the DUT.

## Alarm types and operation

There are two types of alarm based on urgency level: alarm 1 (high urgency) and alarm 2 (low urgency).

### Alarm 1 (high urgency)

This alarm detects anomalies and automatically turns off the load. The operating conditions of this alarm are fixed.

When alarm 1 occurs, immediately remove the cause(s) of the alarm.

Name	Display	Activation condition	Activation
Overvoltage detection	OVP Alarm	Voltage that is equal to or exceeds 110 % of the rated voltage is applied to the load input terminals.	Load off
Reverse-connection detection	Reverse Alarm	Approximately -1 % of the rated current flows through the load input terminals.	Load off
Overheat detection <sup>1</sup>	OTP/Front Alarm	The temperature of the internal devices exceeds the standard.	Load off
Alarm input detection 2	External Alarm	A signal between 1.5 V and 0 V is applied to ALARM INPUT (pin No. 6) of the EXT CONT connector.	Load off
Parallel operation anomaly detection	See the reference.	An anomaly occurred during parallel operation (p.114).	Load off

1. Check whether the air inlet on the front panel and the air outlet on the rear panel are being obstructed.
2. First clear the signal input to the EXT CONT connector, then clear the product alarm.

#### ■ OVP Alarm indication

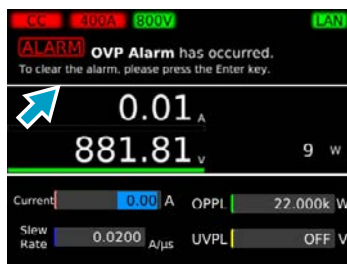

If this happens, immediately lower the voltage of the DUT.

#### ■ Reverse Alarm indication

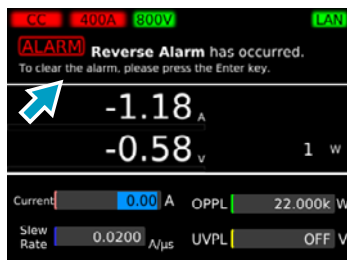

If this happens, immediately shut off the DUT output.



## Alarm 2 (low urgency)

This alarm protects the DUT. The operating conditions of this alarm can be set freely within a given range.

Name	Display	Mode	Activation condition	Activation
Overcurrent protection (OCP)	OCP Alarm	CR CV CP	Current at or exceeding the OCP setting (0 % to 110 % of rated current) flows (p.42).	Load off or limit
Overpower protection (OPP)	OPP Alarm	CC CR CV ARB	Power at or exceeding the OPP setting (0 % to 110 % of rated current) is applied (p.43).	Load off or limit
Undervoltage protection (UVP) <sup>1</sup>	UVP Alarm	CC CR CP ARB	The voltage becomes equal to or less than the UVP setting (0 V to 800 V) (p.44).	Load off, limit, or activation off
Watchdog Protection (WDP)	Watchdog Alarm	All	SCPI communication is not performed for a length of time that is equal to or exceeds the watchdog protection setting (1 s to 3600 s) (p.45).	Load off

1. UVP can be set to off.

## Operating range

The following figure shows the alarm operating range. For details on the operating area of each operation mode, see “Operating Area” (p.151).

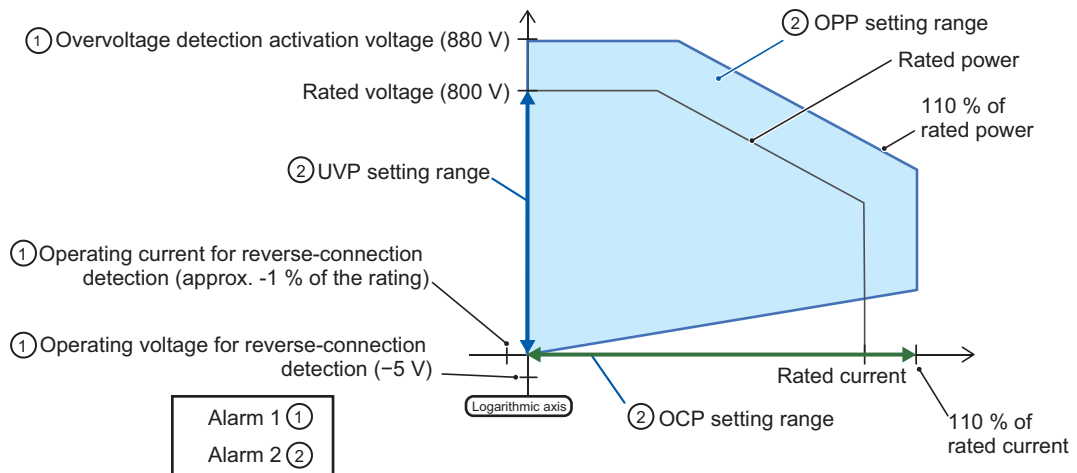

**NOTE**

- The detection points of OCP, OPP, and UVP are the load input terminals of the product. However, when the remote sensing function (p.59) is used, the detection points are the connection points (sensing points).
- The detection points for overvoltage detection and reverse-connection detection are the load input terminals of the product.

## Setting overcurrent protection (OCP)

This function either puts a limit on the current (OCPL) or turns off the load of the product (OCPT) when a current that is equal to or exceeds the set value is running through the product. You can set the overcurrent protection setting and the operation when an alarm occurs.

You can set this function when the load is off. This function operates in CR, CV, and CP modes.

**1** Switch to CR, CV, or CP mode (p.23).

**2** Press Level > OCP.



**3** Use the numeric keypad or the rotary knob to enter the current value.

**4** Press Action and select the operation when an alarm occurs.



Each time you press the key, the item changes.

Item	Description
Trip	Turns the load off. The Action indicator is set to OCPT.
Limit	Limits the current so as not to exceed the set value. The Action indicator is set to OCPL.

This completes the setting.

**NOTE** OCP, OPP, and UVP have factory default settings (p.129).

## Setting overpower protection (OPP)

This function either puts a limit on the power (OPPL) or turns off the load of the product (OPPT) when a current that is equal to or exceeds the set value is applied to the product. You can set the overpower protection setting and the operation when an alarm occurs.

You can set this function when the load is off. This function operates in modes other than CP mode.

**1** Switch to CC, CR, CV, or ARB mode (p.23).

**2** Press Level > OPP.



**3** Use the numeric keypad or the rotary knob to enter the power value.

**4** Press Action and select the operation when an alarm occurs.



Each time you press the key, the item changes.

Item	Description
Trip	Turns the load off. The Action indicator is set to OPPT.
Limit	Limits the power so as not to exceed the set value. The Action indicator is set to OPPL.

This completes the setting.

**NOTE** OCP, OPP, and UVP have factory default settings (p.129).

## Setting undervoltage protection (UVP)

This function limits the current (UVPL) or turns off the load (UVPT) when the voltage applied to the product becomes equal to or less than the UVP setting. You can also turn UVP off. You can set this regardless of whether the load is on or off. This function operates in modes other than CV mode.

**1** Switch to CC, CR, CP, or ARB mode (p.23).

**2** Press Level > UVP.

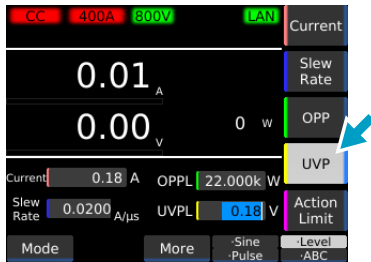

**3** Use the numeric keypad or the rotary knob to enter the voltage value.

To turn this off, turn the rotary knob counterclockwise to select OFF.

**4** Press Action and select the operation when an alarm occurs.

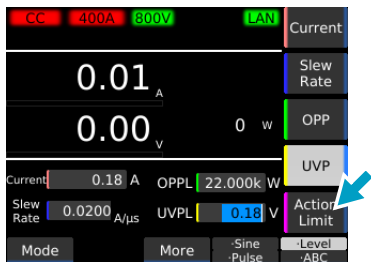

Each time you press the key, the item changes.

Item	Description
Trip	Turns the load off. The Action indicator is set to UVPT.
Limit	Limits the voltage so as not to become equal to or less than the set value. The Action indicator is set to UVPL.

This completes the setting.

- NOTE**
- OCP, OPP, and UVP have factory default settings (p.129).
  - If the +CV mode is added with an SCPI command (p.24), the UVP value is set to the set voltage of the CV mode. If +CV mode is set to on, UVP limit operation is enabled. Otherwise, UVP TRIP operation is enabled.

## Setting watchdog protection (WDP)

This function turns off the load of the product when SCPI communication is performed for a length of time that is equal to or exceeds the WDP setting.

### 1 Press SYSTEM.

The Configure screen appears.  
If the Configure screen does not appear, press Configure.

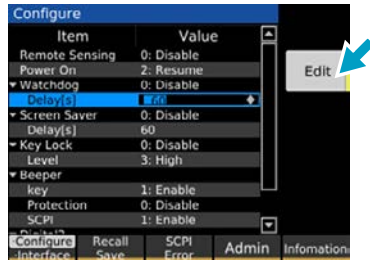

### 2 Use the rotary knob to select Delay under Watchdog, and then press Edit.

### 3 Use the numeric keypad or the rotary knob to enter the time [s], and then press ENTER.

This sets the WDP value.

### 4 Use the rotary knob to select Watchdog, and then press Edit.

### 5 Use the rotary knob to select Enable or Disable, and then press ENTER.

This completes the setting.

## When an alarm occurs

An alarm message appears in the message area of the display. For UVPL, the operation mode display changes to UVP.

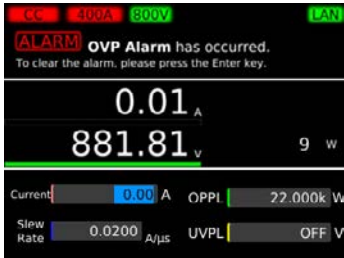

Example when OVP occurs

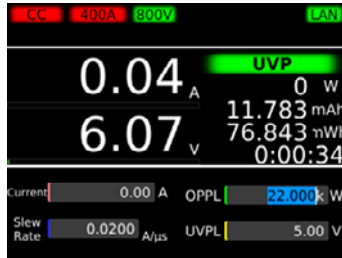

Example when UVP occurs

There are the following status outputs to the EXT CONT connector.

- When overvoltage detection (OVP), reverse-connection detection, overheat detection, alarm input detection, or parallel operation anomaly detection is activated: ALARM1 (terminal 14) switches ON
- When OCP, OPP, UVP or WDP is activated: ALARM2 (pin 15) switches ON

## Clearing an alarm

- 1 Remove the cause of the alarm.
- 2 Press ENTER.

The alarm is cleared.

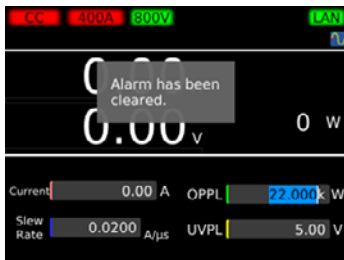

**NOTE**

- If the cause of the alarm remains, the alarm will occur again.
- You can also clear the alarm with an external control signal ([p. 107](#)).

# Recording Measurements

This product shows the most recent measurements (current, voltage, power) on the display. Measurements are recorded in the internal memory (data logging function).

By setting measurement recording conditions (p.48), you can control the timing that measurements are recorded. The recording timing of measurements can be synchronized on synchronized PLZ12005WHs/PLZ20005WHs (p.76).

## Starting measurement recording

### 1 Press MEASURE and then Acquire.

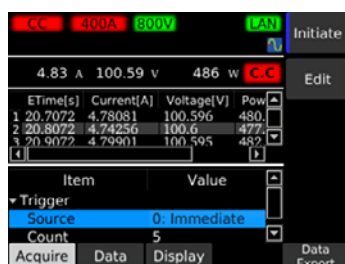

### 2 Press Initiate.

Measurement recording starts. While recording is in progress,  is displayed in the upper right of the display.

## Setting recording conditions

You can set the following measurement recording conditions.

Condition	Value	Description
Trigger	—	Set the measurement recording timing and the number of times to record measurements.
Source	—	Event (trigger source) that defines the measurement recording condition. Recording starts after the Initiate key is pressed and a trigger is received.
	Immediate	Pressing Initiate applies a trigger immediately.
	BUS	Applies a trigger when a *TRG command is received from a PC or when the *TRG key on the front panel is pressed.
	DIGITAL2 <sup>1</sup>	Applies a trigger when a signal is received at pin 13 of the EXT CONT connector.
	MSync	The trigger application timing is synced between the PLZ12005WHs/PLZ20005WHs that are synchronized ( <a href="#">p. 76</a> ).
	TALink	Applies a trigger when a step is executed if Generate is set to TA Link in the sequence step settings ( <a href="#">p. 86</a> ).
	Load Off	Applies a trigger when the load is turned off.
Count	1 to 65536	The number of times to recorded measurements.
Delay	0 $\mu$ s to 100 s (resolution: 10 $\mu$ s)	The delay time from trigger application until measurement recording.
Interval	Disable/Enable	Sets whether to insert an interval between recordings when Count is 2 or higher.
Interval Time	10 $\mu$ s to 3600 s (resolution: 10 $\mu$ s)	Recording interval time when Interval is set to Enable.
Sense Aperture	10 $\mu$ s to 1 s (resolution: 10 $\mu$ s)	Time period of each recording. The average over the time period is recorded.

1. Only when Direction of Digital 2 is set to Input ([p. 121](#)).



## Recording condition setting examples

### ■ Example 1:

- Source: Immediate
- Interval: Disable
- Count: 3

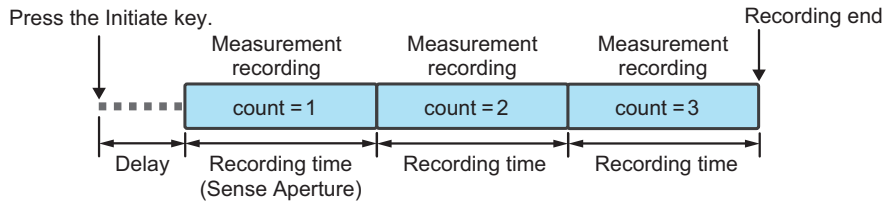

### ■ Example 2:

- Source: BUS, DIGITAL2, TALink, MSync, or Loadoff
- Interval: Disable
- Count: 3

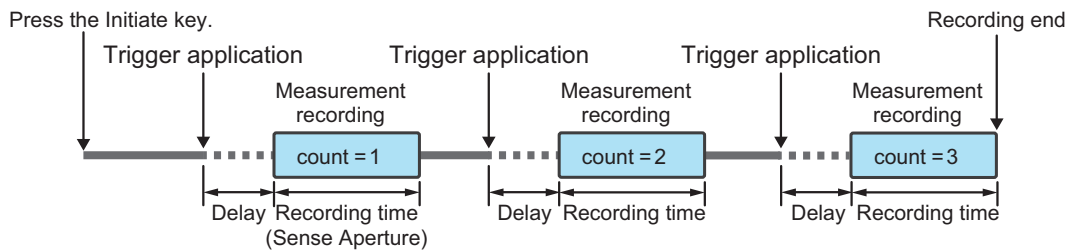

### ■ Example 3:

- Source: Immediate
- Interval: Enable
- Count: 3

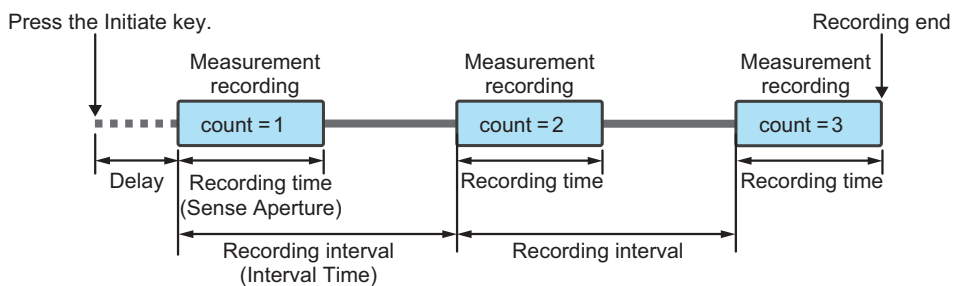

### Measurement recording flowchart

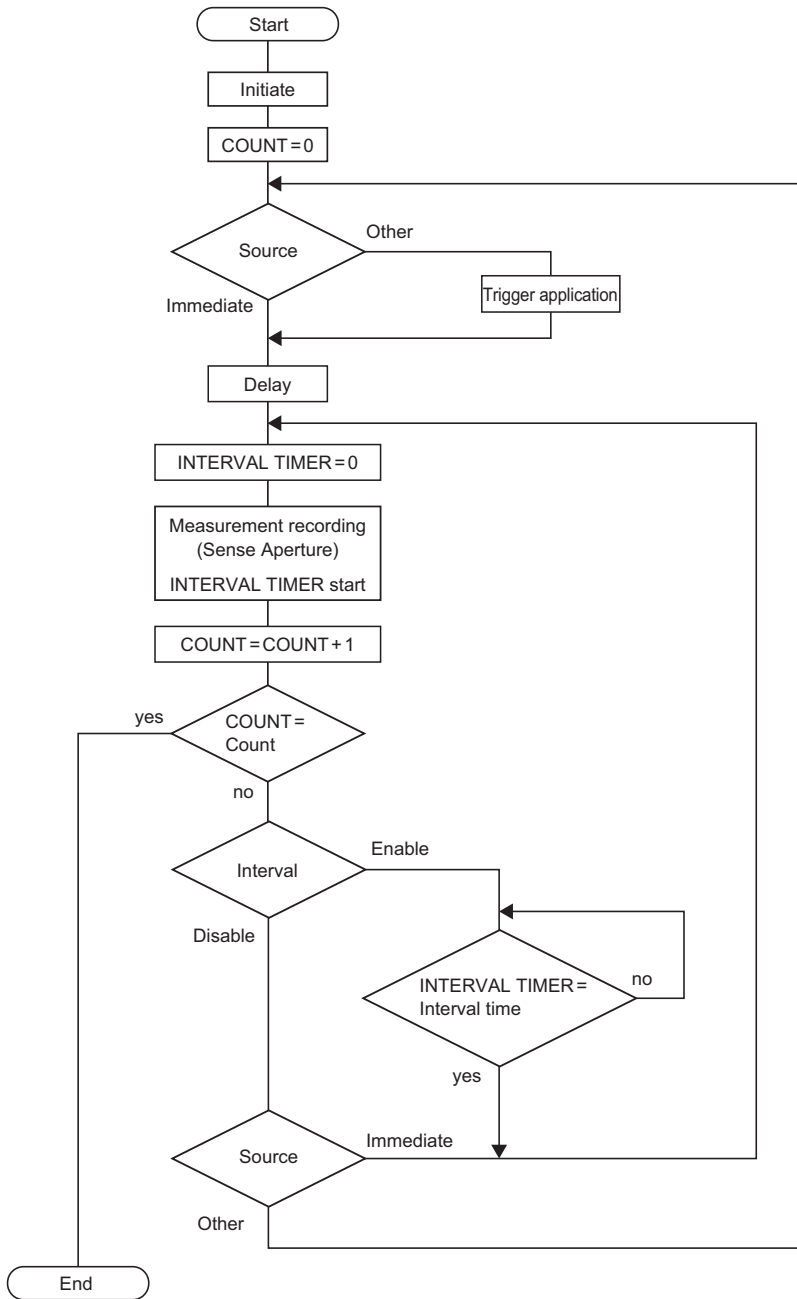

## Setting recording conditions

- 1 Press MEASURE and then Acquire.
- 2 Use the rotary knob to select a measurement recording condition (p.48), and then press Edit.

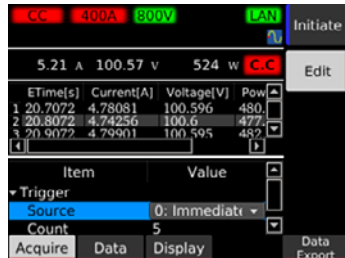

- 3 Use the numeric keypad or the rotary knob to enter a value, and then press ENTER.  
Repeat Step 2 and Step 3 to set the recording conditions.  
This completes the setting.

## Aborting a measurement recording

- 1 Press Abort while measurement is in progress.

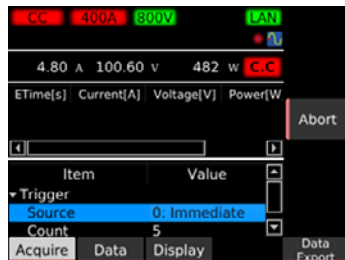

Measurement recording is aborted.

## Displaying the recorded measurement

Measured data can be shown in a table or chart.

### Table display

1 Press MEASURE > Display > Table.

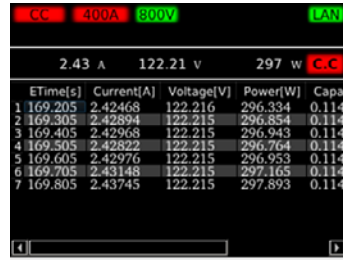
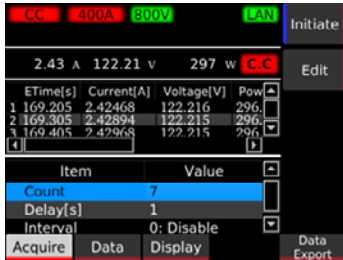

On the main display, use the left and right arrow keys to move between display items and the rotary knob to flip pages.

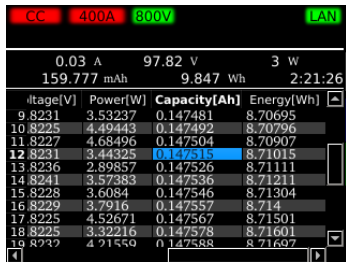

### Chart display

1 Press MEASURE > Display > Chart.

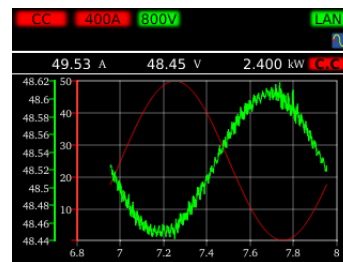
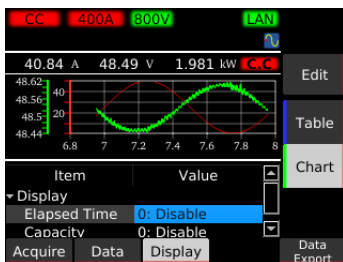

The horizontal and vertical scales are set automatically according to the measurement.

# Recording Integrated Data

## Recording integrated current, integrated power, and elapsed time

Integrated current (Capacity Ah), integrated power (Energy Wh), and elapsed time (s) are called integrated data. You can set the recording period and the reset method of integrated data as in the table below. In the factory default condition, recording starts and stops in sync with load on and off and is reset automatically at the start of recordings.

Parameter	Value	Description
Integral Gate	—	Sets the integrated data recording period.
	None	Recording is started/stopped with the Start key and Stop key.
	Load On	Recording is started/stopped in synchronization with load on/load off. Or, recording is started or stopped manually.
	Program Run	Recording is started/stopped in synchronization with sequence execution start/stop. Or, recording is started or stopped manually.
Reset	—	Selects the integrated data reset method. If the product is restarted, integrated data is reset.
	Manual	Integrated data is reset only when the Reset key is pressed.
	Auto	Integrated data is automatically reset before the start of recordings. Or, integrated data is reset when the Reset key is pressed.

Example: Integral Gate is set to Load On, and UVP is set

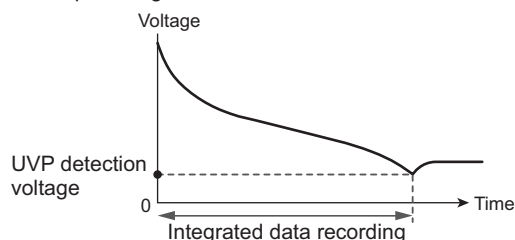

## Setting the recording period and reset method of integrated data

- 1 Press **MEASURE** and then **Data**.
- 2 Use the rotary knob to select the item, and then press **Edit**.

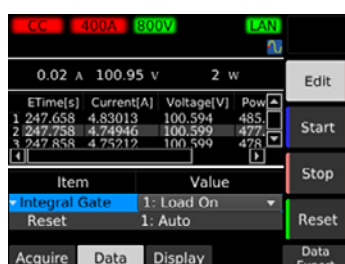

- 3 Use the rotary knob to select the value, and then press **ENTER**.

Repeat Step 2 and Step 3 to set the recording period and reset method.

This completes the setting.

## Recording integrated data manually

### 1 Press MEASURE and then Data.

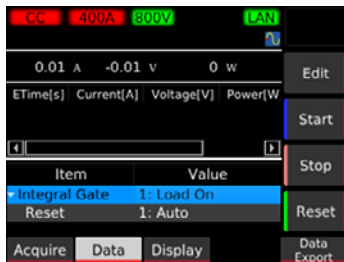

### 2 Press Start.

Integrated data recording starts.

### 3 Press Stop.

Integrated data recording stops.

## Resetting integrated data

### 1 Press MEASURE and then Data.

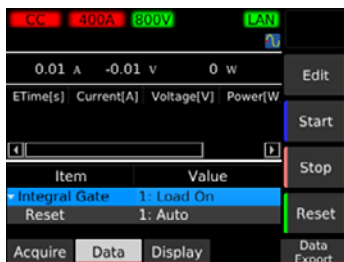

### 2 Press Reset.

This resets the integrated data.

## Showing or hiding integrated data

You can show or hide integrated data. This is useful for example for battery discharge tests. By factory default, the integrated current and integrated power are not shown.

- 1 Press MEASURE > Display.
- 2 Use the rotary knob to select the item, and then press Edit.

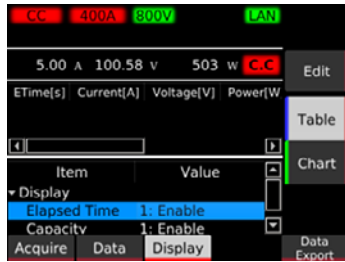

Item	Value	Description
Display	Elapsed Time	Enable/Disable
	Capacity	Enable/Disable
	Energy	Enable/Disable

**NOTE** There is a  $\pm 1$  second error between the elapsed time recording (p.53) and elapsed time display.

- 3 Use the rotary knob to select Enable (show) or disable (hide), and then press ENTER. This completes the setting.

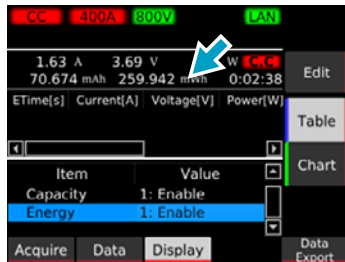

Display example of integrated current, integrated power, and elapsed time

# Saving Measurement Data to USB Memory

Measurement data can be stored in CSV format to a USB memory device.

- 1 Press MEASURE > Data Export.**
- 2 Insert a USB memory device into the USB port on the front panel.**  
The device appears as sdxx. You can save CSV data to this device.

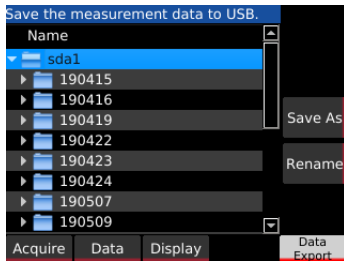

- 3 Use the rotary knob to select a directory in the USB memory device.**  
The top directory, sdxx, is the root directory of the USB memory device.

- 4 Press Save As.**  
The CSV data is saved.

- 5 Enter a file name.**  
Use the up and down arrow keys to select characters and the left and right arrow keys to move the cursor. When the cursor is at the right of the last character, pressing the right arrow key inserts the selected character.



- 6 Press ENTER to confirm the file name.**

## CSV data

Example: Format of the CSV data saved to a USB memory device

ETime[s]	Carrent[A]	Voltage[V]	Power[W]	Capacity[Ah]	Energy[Wh]
30.92355	0.556787	4.305881	2.397457	0.018838	0.087071
31.02355	0.679384	4.305859	2.925332	0.018857	0.087152
31.12355	1.823047	4.305092	7.848385	0.018908	0.08737



# Advanced Functions

## Changing the Response Speed

Set the response speed for CV, CR, or ARB mode according to the DUT's conditions and application. In CV or CR mode, the factory default setting is "Normal". You can make the response speed faster by setting "Fast". In ARB mode, the factory default setting is "500  $\mu$ s".

**NOTE** When the response speed is set to Fast, the operation may become unstable if the load cable is long or has a large loop. In that case, set the response speed to Normal.

- 1 Switch to CV, CR, or ARB mode (p.23).
- 2 Press SOURCE and then More.
- 3 Use the rotary knob to select the following items under Response, and then press Edit.



Item	Description
Voltage	Set the response speed for CV mode. Normal, Fast
Conductance	Set the response speed for CR mode. Normal, Fast
ARB	Set the response speed for ARB mode. The value is the filter response time. Select OFF for no filter. OFF, 500 $\mu$ s, 1 ms, 2 ms, 5 ms, 10 ms, 20 ms, 50 ms, 100 ms

- 4 Use the rotary knob to select Normal or Fast, and then press ENTER.  
For ARB, select the response speed (500  $\mu$ s, 1 ms, 2 ms, 5 ms, 10 ms, 20 ms, 50 ms, 100 ms) or OFF.  
This completes the setting.

# Soft Start

Soft start is a function that controls the rise time of the load current.

Soft start functions only when all the following conditions are met.

- The rise time of the soft start has been set.
- Load on state in constant current (CC) mode.
- There is an input that is equal to or exceeds the minimum operating condition, from the state where there is no input to the load input terminals.

If the load current rises sharply, the DUT output may become unstable or the DUT's overcurrent protection circuit may be activated. In such situations, it is possible to make the load current to rise slowly only when the product is started.

■ When soft start has been disabled

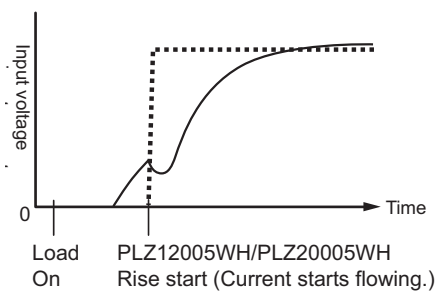

■ When soft start has been set properly

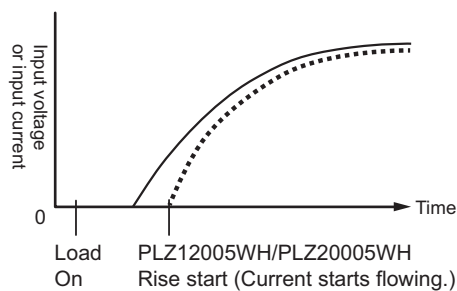

— DUT's voltage waveform  
 ..... PLZ12005WH/PLZ20005WH current waveform

For the conditions for the current to flow through the PLZ12005WH/PLZ20005WH, see "Operating Area" (p.151).

**1** Press **SOURCE** and then **More**.

**2** Use the rotary knob to select **Soft Start**, and then press **Edit**.



**3** Use the rotary knob to select the soft start time, and then press **ENTER**.

Selecting Off disables soft start.

This completes the setting.

# Remote Sensing

You can change a voltage measurement point from a load input terminal to an arbitrary sensing point. By setting sensing points at the DUT end, influences such as voltage drops caused by the resistance of the load cables can be reduced, and the load current can be stabilized.

To use remote sensing, connect the sensing cables to the product's SENSING terminals (+S, -S) and the DUT terminals, and enable remote sensing in the SYSTEM menu.

## Connecting cables to the safety terminal adapters

When connecting sensing cables to the SENSING terminals, use the included safety terminal adapters (TL41).

Use sensing cables with a withstanding voltage of at least 800 V. There is no need to consider the allowable current as with the load cables. Cable diameter with a nominal cross-sectional area between 0.75 mm<sup>2</sup> and 2.5 mm<sup>2</sup> (AWG18 and AWG14) is compatible with the safety terminal adapter.

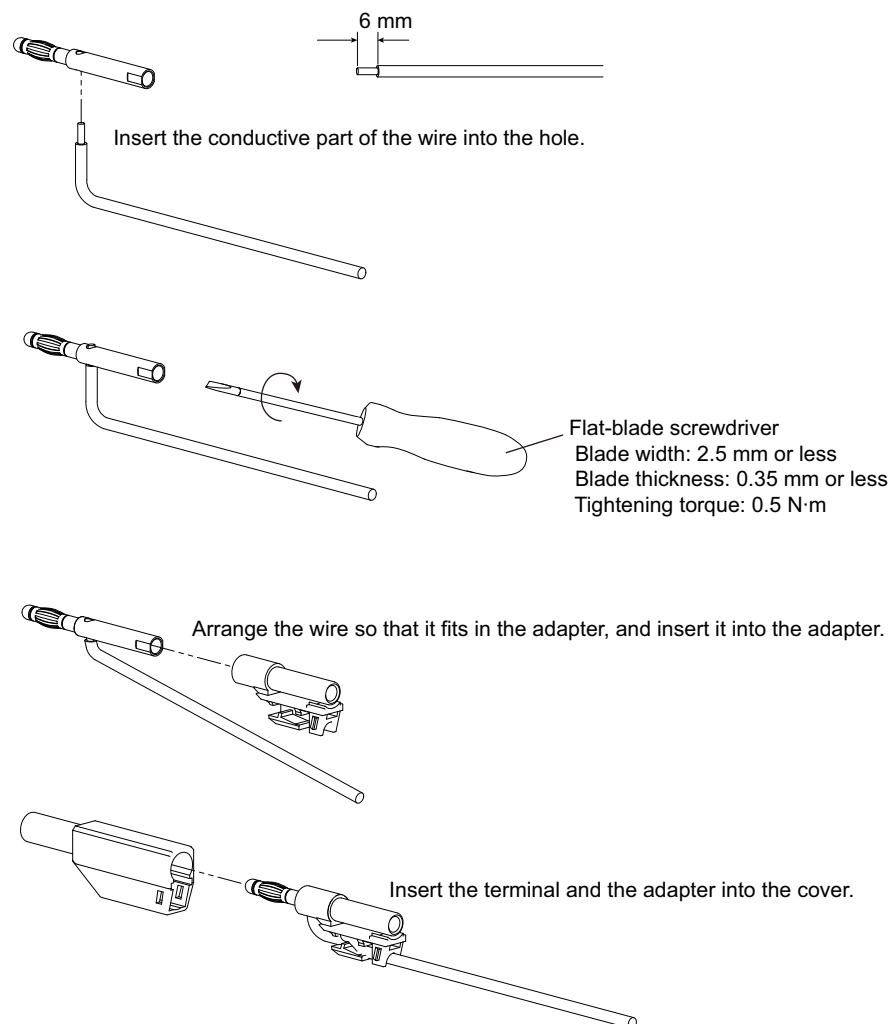

## Connecting the sensing cables

**⚠ CAUTION**

- Risk of damage to the internal circuitry. Never connect cables to the SENSING terminals while the POWER switch is turned on.
- If the remote sensing cables come loose while remote sensing is in use, the product and DUT may be damaged. Be sure to connect the cables securely.

- 1 Turn the POWER switch off.**
- 2 Connect the sensing cables to the product.**

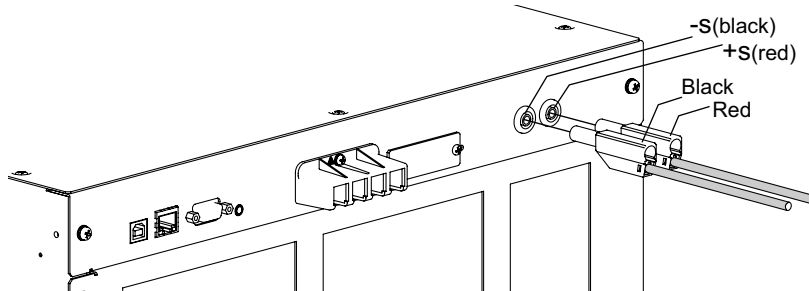

- 3 Connect the sensing cables to the DUT.**

Match the polarities of the sensing terminals with those of the DUT terminals during connection.

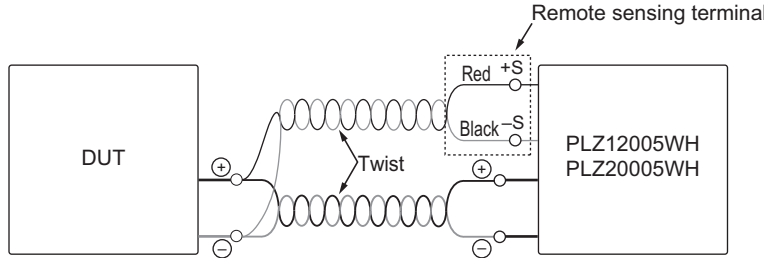

This completes the connections.

## Enabling or disabling remote sensing

After connecting the sensing cables, enable remote sensing.

Remote sensing can be set when the load is turned off and sequence operation is stopped.

### 1 Press SYSTEM.

If the Configure screen does not appear, press Configure.

### 2 Use the rotary knob to select Remote Sensing, and then press Edit.

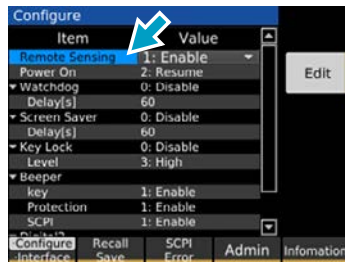

### 3 Use the rotary knob to select Enable or Disable, and then press ENTER.

If you select Enable,  appears in the upper right of the display.

This completes the setting.

# Cutoff function

This function turns the load off when the elapsed time from load-on, the voltage drop, the integrated current, or the integrated power reaches the specified value. These four functions are collectively referred to as cutoff.

## Setting the cutoff activation condition

Multiple cutoffs can be specified simultaneously. If any of the cutoff items is enabled, an icon (  ) appears in the top area of the display. If a cutoff is activated, the icon corresponding to the item that caused it appears in the top area of the display (p. 65).

Cutoff item	Description
Elapsed time	The load turns off when the elapsed time value reaches the specified value.
Voltage drop <sup>1</sup>	The load turns off when the voltmeter value reaches the specified value.
Integrated current	The load turns off when the ampere-hour meter value reaches the specified value.
Integrated power	The load turns off when the watt-hour meter value reaches the specified value.

1. The same operation is performed using Trip (UVPT) of the constant voltage protection (UVP), but whereas when an UVPT is activated, an alarm occurs, in the case of cutoff, an alarm does not occur.

- 1 Press SOURCE > More.
- 2 Use the rotary knob to select State under the item you want to set, and then press Edit.
  - For elapsed time, select State under ETime.
  - For voltage drop, select State under Voltage.
  - For integrated current, select State under Capacity.
  - For integrated power, select State under Energy.

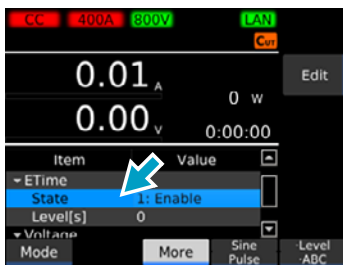

- 3 Use the rotary knob to set Enable or Disable, and then press ENTER.

- 4** If set to Enable, use the rotary knob to select Level, and then press Edit.



- 5** Use the numeric keypad or the rotary knob to enter the value for activating the cut-off, and then press ENTER.

Parameter	Setting range	Resolution
Elapsed time	0 s to 3600000 s (1000 h 0 min 0 s)	1 s
Voltage drop	0.00 V to 800.00 V	0.02 V
Integrated current	0.000 mAh to 800.000 kAh (PLZ12005WH) 0.000 mAh to 1400.000 kAh (PLZ20005WH)	0.001 mAh (0.000 mAh to 1000.000 mAh) 0.001 Ah (1.001 Ah to 1000.000 Ah) 0.001 kAh (1.001 kAh to 1000.000 kAh) 0.001 MAh (1.001 MAh to 1.400 MAh)
Integrated power	0.000 Wh to 400.000 MWh (PLZ12005WH) 0.000 Wh to 650.000 MWh (PLZ20005WH)	0.001 Wh (0.000 Wh to 1000.000 Wh) 0.001 kWh (1.001 kWh to 1000.000 kWh) 0.001 MWh (1.001 MWh to 650.000 MWh)

This completes the setting.

## Cutoff operation

Cutoff is activated based on integrated data (p. 61). The operation necessary before and after the cutoff varies depending on the integrated data recording setting.

### ■ Relationship between the cutoff activation condition, integrated data setting, and load on/off

Example: When the enabled cutoff activation condition is set only to elapsed time (ETime) and Level is set to 10 seconds

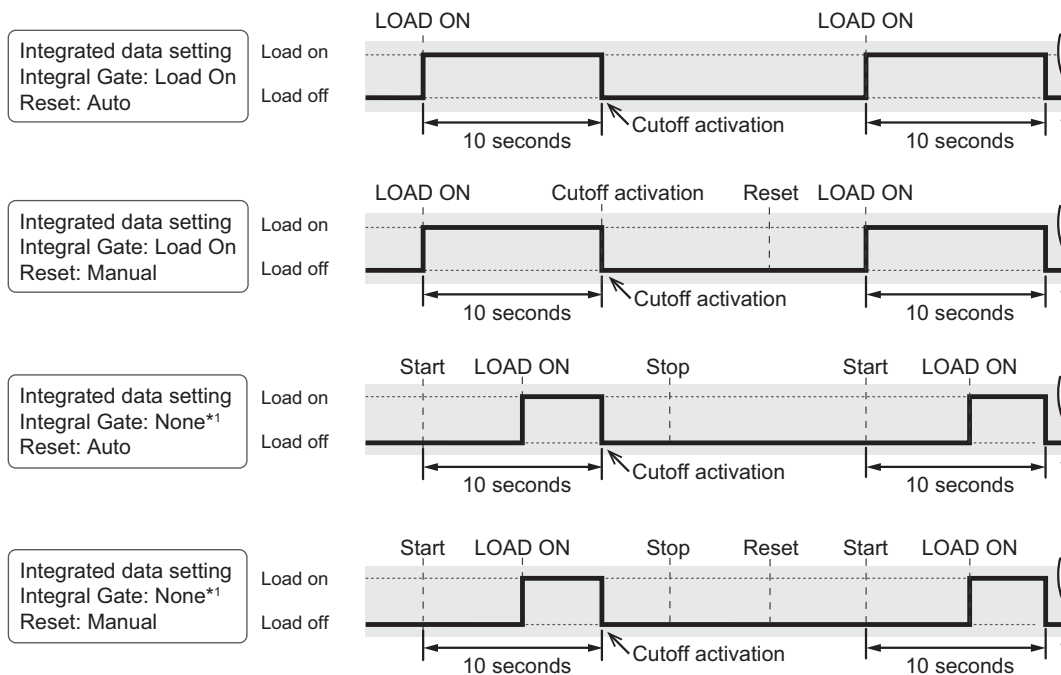

\*1 When Integral Gate is set to Program Run, the operation is similar as when None is specified. Read Start as sequence start, Stop as sequence stop, and LOAD ON as Load On step start.

### ■ Turning the load on again after cutoff

Even when the load is turned on, if the cutoff activation condition is satisfied, the cutoff is activated immediately and the load turns off. To turn the load on again, reset the integrated data, change the cutoff activation condition, or disable the cutoff that caused the activation.



## When cutoff is activated

When any of the enabled cutoff items (elapsed time, voltage drop, integrated current, or integrated power) reaches the specified value, cutoff is activated, and the load turns off. If a cutoff is activated, the icon corresponding to the item that caused it appears in the top area of the display. The activation cause icon remains displayed until the load is turned on the next time.

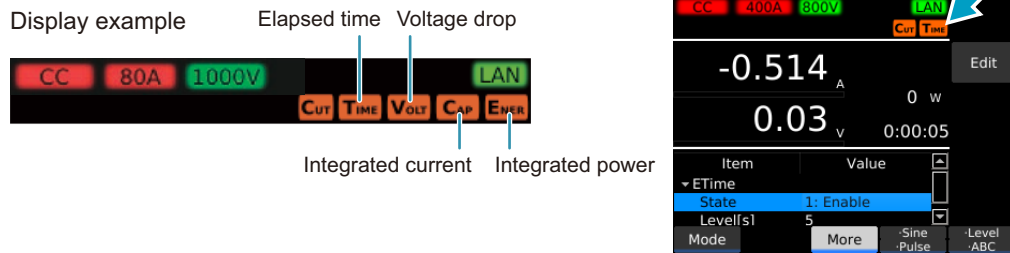

### NOTE

If a cutoff occurs due to a voltage drop, check the DUT state before measuring again.

# Types of Memory

The product has two types of memory, ABC preset memories and setup memory.

ABC preset memories are for storing three sets (A, B, and C) of load values. Because you can recall saved settings just by pressing a key, this feature is useful when you want to switch between the three sets of values in order.

Setup memory stores all basic settings.

## ■ Differences between ABC preset memories and setup memory

Item	ABC Preset Memories	Setup Memory
Number of memory entries	3	20 (internal memory) Depends on the memory size (USB memory)
Memory name	A, B, C	0 to 19 (internal memory) Any name (USB memory)
Saved setting	Load values for each operation mode (current, voltage, conductance, power)	Operation mode Load values (current, voltage, conductance, power) Slew rate Pulse amplitude Pulse interval Sine amplitude Sine frequency Alarm 2 operating conditions ABC preset memories
When load is on	Memory entries can be saved or recalled.	Memory entries can be saved but not recalled
When load is off	Memory entries can be saved or recalled.	Memory entries can be saved or recalled.

# ABC Preset Memories

Load values can be saved in any of the three memories A, B, or C.

The load values for each operation mode saved to the memories are as follows.

Operation mode	Load value
CC mode	Current
CR mode	Conductance
CP mode	Power
CV mode	Voltage
ARB mode	Number of table rows, voltage, current

## Saving to ABC preset memories

You can save settings regardless of whether the load is on or off. Alarm operating conditions are not saved.

**1 Enter the load values for the operation mode to be saved.**

**2 Press ABC to select ABC.**

Each time you press the key, the selected item changes.

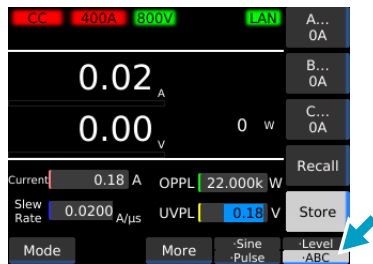

**3 Press Store.**

**4 Press a sub-function keys to select the memory (A, B, C) you want to save to, and then press ENTER.**

A confirmation pop-up message appears. Use the left and right arrow keys to select OK, and press ENTER.



**5 Press ENTER.**

The settings are saved to the selected memory. If setting have already been saved, they are overwritten.

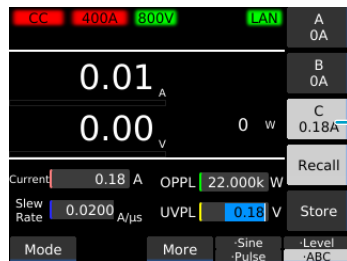

The saved load value is displayed. (except ARB mode)

Example: CC mode, saved to memory C

## Recalling ABC preset memory entries

You can recall settings regardless of whether the load is on or off.

If the settings that you recall cause alarm operating conditions to be exceeded, an alarm will occur.

**NOTE** Alarm operating conditions are not saved to ABC preset memories.

### 1 Set the operation mode to the same setting as that in the memory you want to recall.

Memories cannot be recalled if the operation mode is different.

### 2 Press ABC to select ABC.

Each time you press the key, the selected item changes.

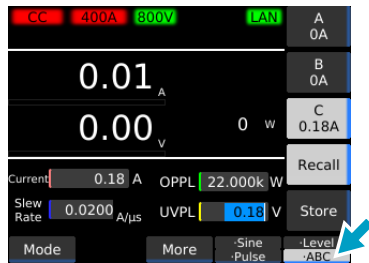

### 3 Press Recall.

### 4 Press the sub-function key (A, B, or C) for the memory to be recalled.

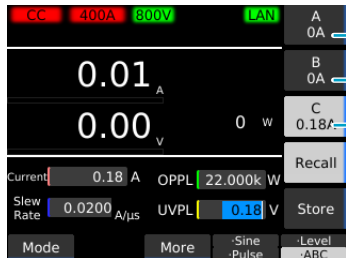

The saved load value is displayed.  
(except ARB mode)

Example: CC mode

The preset memory is recalled.

# Setup Memory

The setup memory can store up to 20 sets (0 to 19) of the current conditions of the items listed below. The current conditions can also be saved in a USB memory device.

- Load on/off state
- Operation mode
- Load values (current, voltage, conductance, power)
- Slew rate
- Pulse amplitude (current/conductance or percentage)
- Pulse interval (frequency/time of one cycle and duty cycle/operating time on the high side)
- Sine amplitude (current)
- Sine frequency
- Alarm operating conditions
- Content of ABC preset memories

### ■ Loading a file saved on the PLZ-5W into the PLZ12005WH/PLZ20005WH (USB memory device)

A file saved on the PLZ-5W (PLZ205W, PLZ405W, PLZ1205W) to a USB memory device can be loaded into this product. All the above items can be loaded, but the following operations will be different.

- If +CV mode is set on the PLZ-5W, the UVP action of this product will be Limit.
- If +CV mode is not set on the PLZ-5W, the UVP action of this product will be Trip.
- The current ranges and voltage ranges set on the PLZ-5W are handled as PLZ-5W's H range on this product.

### ■ Loading a file saved on the PLZ12005WH/PLZ20005WH into the PLZ-5W (USB memory device)

- If the UVP action is set to Limit on this product, +CV mode will be set on the PLZ-5W (PLZ205W, PLZ405W, PLZ1205W).

## How to view the setup memory edit screen

Press SYSTEM and then Recall Save to display the setup memory edit screen. The internal memory contains an empty setup memory set. Connecting a USB memory device to the USB port on the front panel displays an "sdx" folder (the "xx" changes depending on the USB memory device) enabling you to save and recall the setup memory from the USB memory device.

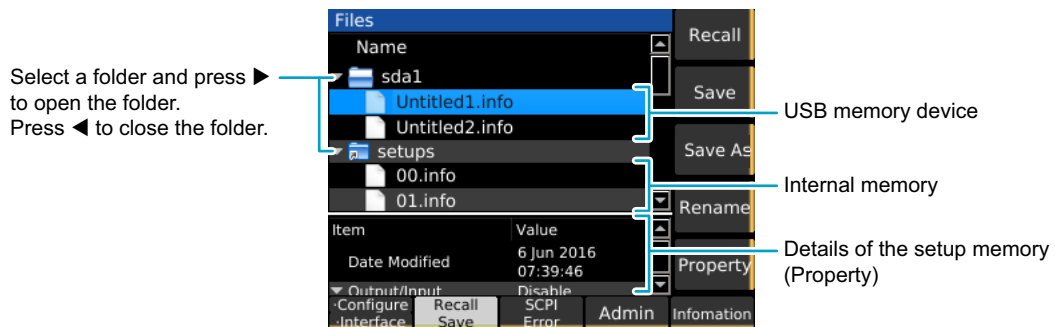

# Saving to the setup memory

This section explains how to save the product's settings to the setup memory.

## Saving over previous settings (internal memory and USB memory)

- 1** Set the operation mode and settings to the states you want to save them in.
- 2** Press **SYSTEM** and then **Recall Save**.

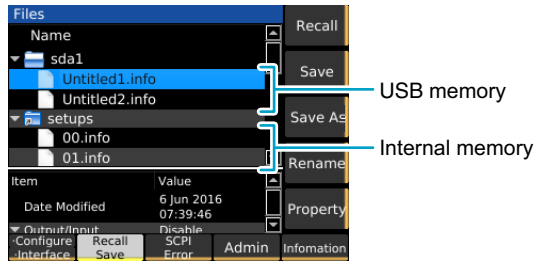

Connecting a USB memory device to the USB port on the front panel displays an “sdxx” folder (the “xx” changes depending on the USB memory device).

- 3** Use the rotary knob to select the setup memory.
- 4** Press **Save**.  
The setting contents are saved to the setup memory.

## Saving to a new file (USB memory device only)

- 1** Set the operation mode and settings to the states you want to save them in.
- 2** Press **SYSTEM** and then **Recall Save**.
- 3** Insert a USB memory device into the USB port on the front panel.  
An “sdxx” folder is displayed. The “xx” changes depending on the USB memory device.
- 4** Use the rotary knob to select the sdxx folder, and press **Save As**.  
A new setup memory is created.

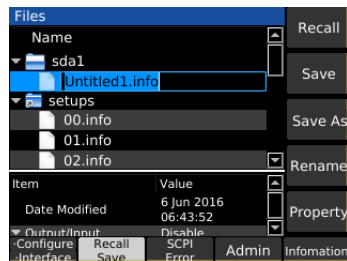

- 5** Use the numeric keypad or the rotary knob to enter a file name of your choice, and then press **ENTER**.  
Be sure to add an extension (.info) to the file name.  
The setup memory is saved to a new file.

## Changing the memory name (USB memory device only)

- 1** Press **SYSTEM** and then **Recall Save**.
- 2** Insert a **USB memory device** into the **USB port** on the front panel.  
An “sdxx” folder is displayed. The “xx” changes depending on the USB memory device.
- 3** Use the rotary knob to select the setup memory, and press **Rename**.

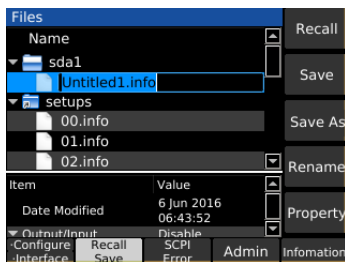

- 4** Use the numeric keypad or the rotary knob to enter a file name of your choice, and then press **ENTER**.  
Be sure to add an extension (.info) to the file name.  
The memory name is saved.

## Checking the setup memory details

- 1** Press **SYSTEM** and then **Recall Save**.
- 2** Use the rotary knob to select the setup memory.
- 3** Press **Property**.  
The detailed information of the setup memory is displayed. The detailed information can be scrolled by using the rotary knob.  
Press **Property** again to return to the original state.

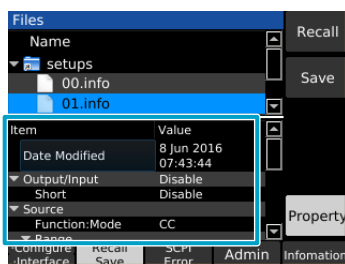



## Recalling the setup memory

You can recall memory content when load is turned off.

**1 Press SYSTEM and then Recall Save.**

**2 Use the rotary knob to select the setup memory.**

Press Property to view the setting content of the setup memory.

Connecting a USB memory device to the USB port on the front panel displays an “sdxx” folder (the “xx” changes depending on the USB memory device).

**3 Press Recall.**

The setting content of the selected setup memory is recalled.

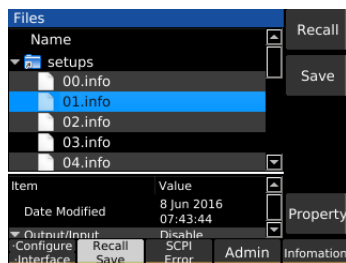

# Synchronized Operation

If you interconnect the PLZ12005WHs/PLZ20005WHs with LAN cables, synchronized operation can be performed from any of the connected PLZ12005WHs/PLZ20005WHs.

- Synchronizing the load on/off operation
- Synchronizing measurement recording (remote control only)
- Synchronizing the starting and resuming of sequences

PLZ12005WHs and PLZ20005WHs can be connected together. Synchronized operation is possible even during parallel operation.

## ■ Simple setting using LAN cables

Common LAN cables (straight-through) up to 30m long can be used. If you need to use a LAN cable longer than 30 m, please contact your Kikusui agent or distributor.

### **WARNING** Risk of electric shock.

- Do not touch the IN/OUT connectors of EXT SYNC while the power is turned on.
- Do not leave one end of the LAN cable connected to the EXT SYNC port when the other end is not connected.

## Connection for synchronized operation (steps 1 to 4)

- 1** Turn the POWER switches of all the PLZ12005WHs/PLZ20005WHs that you will connect.
- 2** Remove the SYNC/PARALLEL port cover.

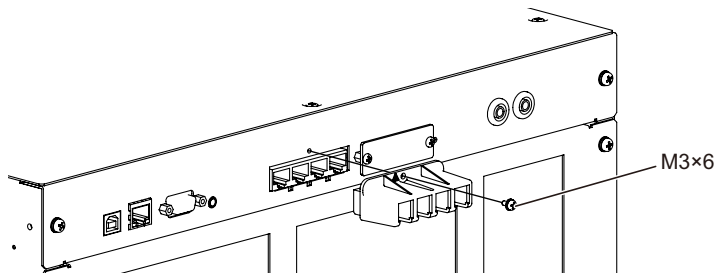

**3 Connect all the PLZ12005WHs/PLZ20005WHs with LAN cables.**

Connect the OUT port of EXT SYNC of the product to the IN port of EXT SYNC of another unit with a LAN cable.

Connection example

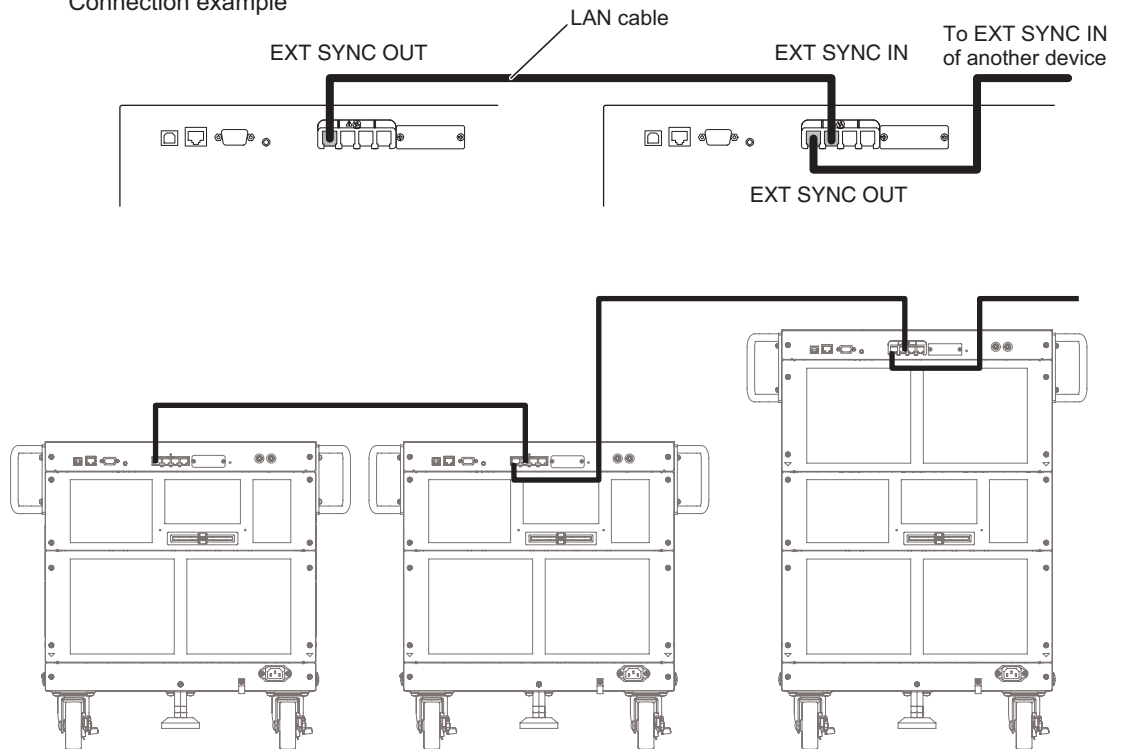

**4 When you complete the connection, attach the SYNC/PARALLEL port cover.**

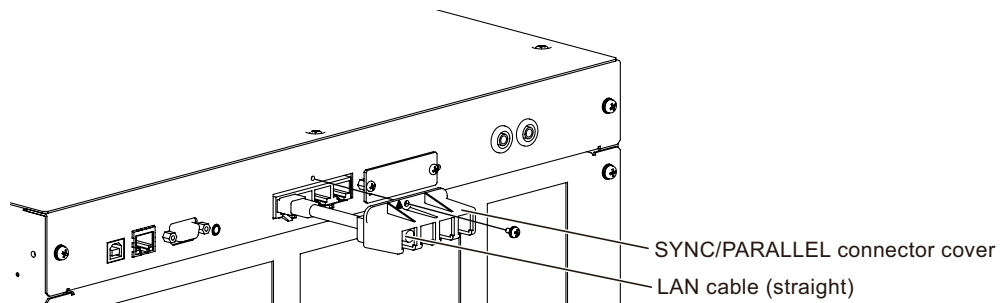

This completes the connections.

## Synchronizing the load on/off operation

You can synchronize the load on/off operation on multiple synchronized PLZ12005WHs/PLZ20005WHs.

**1 Press SOURCE and then More.**

**2 Press Sync Enable.**

Load on/off synchronization switches between enabled and disabled each time you press the key. When load on/off synchronization is enabled, “Load On” and “Load Off” appear in the sub-function area.



**3 Perform Step 1 and Step 2 on all PLZ12005WHs/PLZ20005WHs to be synchronized.**

**4 Press Load On or Load Off on any of the synchronized PLZ12005WHs/PLZ20005WHs.**

The load on/off operation will be synchronized among all PLZ12005WHs/PLZ20005WHs whose load on/off synchronization was enabled.

## Synchronizing measurement recording

Measurement recording (p.47) can be synchronized among multiple synchronized PLZ12005WHs/PLZ20005WHs. To synchronize, you need to enter a command through remote control.

**1 Press MEASURE and then Acquire.**

**2 Use the rotary knob to select Source, and then press Edit.**

**3 Use the rotary knob to select MSync, and then press ENTER.**



**4 Press Initiate.**

- 5 Perform Step 1 and Step 4 on all PLZ12005WHs/PLZ20005WHs to be synchronized.
- 6 Press MSync on any of the synchronized PLZ12005WHs/PLZ20005WHs.  
Measurement starts simultaneously on all synchronized PLZ12005WHs/PLZ20005WHs.

## Synchronizing the start of sequences

The start of sequences can be synchronized among multiple synchronized PLZ12005WHs/PLZ20005WHs. To synchronize, you first need to create a sequence (p.80).

- 1 Press SEQUENCE and then More.
- 2 Use the rotary knob to select Trigger Source, and then press Edit.
- 3 Use the rotary knob to select MSync, and then press ENTER.



- 4 Run the sequence (p.94).

The sequence pauses before executing the first step, and “MSync” appears in the sub-function area.



- 5 Perform Step 1 and Step 4 on all PLZ12005WHs/PLZ20005WHs to be synchronized.
- 6 Press MSync on any of the synchronized PLZ12005WHs/PLZ20005WHs.  
Sequence starts simultaneously on all synchronized PLZ12005WHs/PLZ20005WHs.

## Synchronizing the resuming of sequences

A sequence will stop at a step with Wait (pre) set to MSync (p.86).

The resuming of a paused sequence (trigger wait) can be synchronized on multiple synchronized PLZ12005WHs/PLZ20005WHs. To synchronize, you first need to create a sequence (p.80).

### 1 Press Sequence, Transient, and then Initiate on all PLZ12005WHs/PLZ20005WHs to be synchronized.

The sequence is executed.

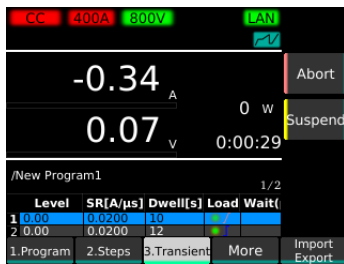

### 2 Wait for the sequence on all synchronized PLZ12005WHs/PLZ20005WHs to be paused.

The sequence pauses before executing a step with Wait (pre) set to MSync, and “MSync” appears in the sub-function area.



### 3 Press MSync on any of the synchronized PLZ12005WHs/PLZ20005WHs.

Sequence resumes simultaneously on all synchronized PLZ12005WHs/PLZ20005WHs.

## Aborting synchronized operation

The synchronized operation setting is cleared when you remove the LAN cables.

#### **⚠ WARNING**

**Risk of electric shock.**

- Do not touch the IN/OUT connectors of EXT SYNC while the power is turned on.
- Do not leave one end of the LAN cable connected to the EXT SYNC port when the other end is not connected.

# Remote Control

In addition to using the front panel, you can also control the product remotely by sending commands. For details on remote control, see the Communication Interface Manual on the included CD-ROM.

## Releasing remote control

You can return the product's control from remote control (the product's panel control not accepted) to local control (panel control accepted). While remote control is in progress, the remote icon appears on the display.

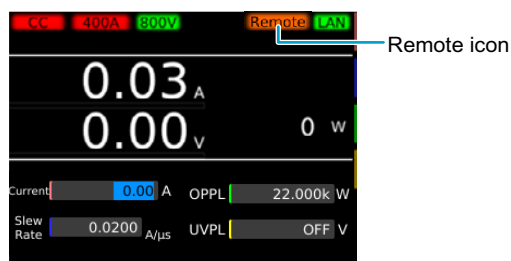

### 1 Press LOCAL.

This switches the operation from remote operation to local operation.

# Sequence Function

## Overview of the Sequence Function

Sequence is a function that executes a sequence of operations set in advance.

### Programs and steps

A sequence consists of programs and steps. A program is a collection of steps. Steps are executed in order one at a time, starting from step 1. The completion of the last step signifies that the program has been executed once.

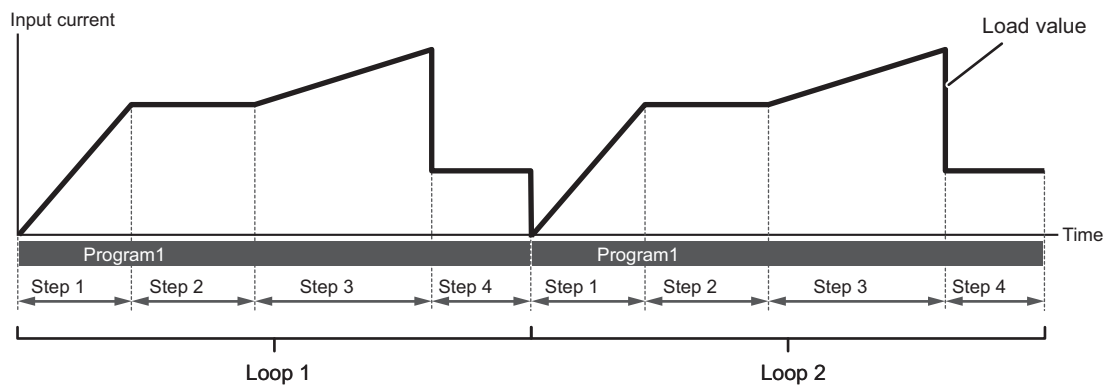

Set a program for each operation mode. Up to 30 programs can be set.  
Up to 10000 steps total can be used in all programs

### Main functions

Setting range	Setting	Description
By step	Load value	Current, conductance, voltage, power. The values that can be set depend on the current operation mode.
	Slew rate	Sets the speed of change when the current is changed.
	Step execution time	0.000050 s to 3600000 s (50 $\mu$ s to 1000 h), resolution: 1 $\mu$ s
	Load on/off control	To turn the load on, set the load setting transition method to step or ramp.
	Other	Trigger signal setting, trigger signal output
For each program	Number of loops of program	1 to 100000 repetitions, or infinite repetitions.
	Protection function	Specifies the value at which a protection function (OCP, OPP, UVP) is activated.



# Program Configuration

You can set programs in CC, CR, CV, and CP modes (ARB mode is excluded). Different programs are created for each operation mode.

## How to view the program editing screen

Press SEQUENCE and then Program to display the sequence editing screen.

The program created in the present operation mode is displayed. When you change the operation mode (p.23), programs that were created in each operation mode are displayed.

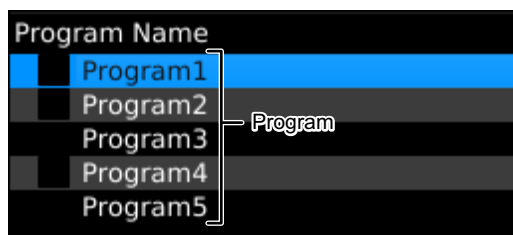

Example: Programs 1 to 5 have been registered

## Creating a program

First, create an empty program without registering any steps.

Because the location where the program is created depends on the present operation mode, even if a program of the same name is created for example in CC mode and CP mode, the resulting programs will be treated as different programs.

The created program is automatically saved and is not deleted even if the POWER switch is turned off.

- 1 Set the operation mode (p.23).**
- 2 Press SEQUENCE and then Program.**  
The program editing screen appears.
- 3 Press Create.**

If another program has a check mark (is selected), you cannot create a program. If this happens, press Select to remove the check mark.

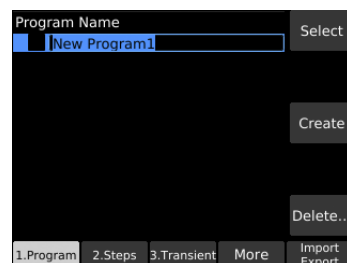

- 4 Use the numeric keypad or the rotary knob to enter the program name, and then press ENTER.**

You can enter up to 255 characters for the program name. For information about registering steps to a program, see "Setting Steps" (p.86).

An empty program is created.

## Setting the number of loops

Set the number of loops of the program.

- 1** Press **SEQUENCE** and then **Program**.
- 2** Use the rotary knob to select the program, and then press **Select**.  
A check mark appears to the left of the selected program name.



- 3** Press **Steps**, **Property**, and then **Loop**.

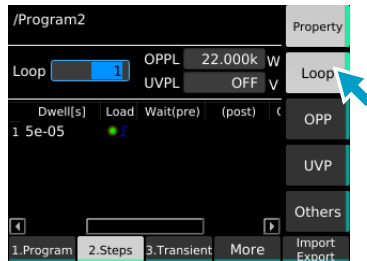

- 4** Use the numeric keypad or the rotary knob to enter number of loops.  
This completes the setting.

## Setting protection functions

For each program, you can set overcurrent protection (OCP), overpower protection (OPP), and undervoltage protection (UVP) in a program. You cannot change the value of each protection function at the step level. The protection functions that you can set varies depending on the operation mode.

**1 Press SEQUENCE and then Program.**

**2 Use the rotary knob to select the program, and then press Select.**

A check mark appears to the left of the selected program name.

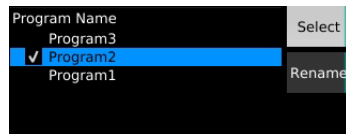

**3 Press Steps, Property, and then OPP, OCP, or UVP.**

The key names that appear vary depending on the operation mode.

You can select the operation (trip or limit) when an alarm occurs using the Action key.

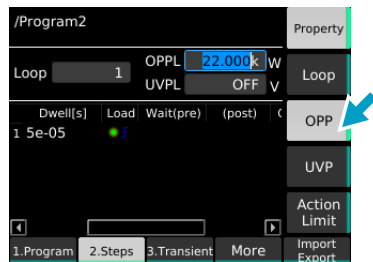

**4 Use the numeric keypad or the rotary knob to enter the value.**

This completes the setting.

## Setting the load state at the end of the sequence

You can set the load state (load on or off, load value, slew rate) at the end of the sequence of a program. If this function is disabled, at the end of the sequence, the load is set to the value of the last step.

**1 Press SEQUENCE > Program.**

**2 Use the rotary knob to select a program, and then press Select.**

A check mark appears to the left of the selected program name.

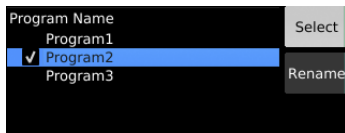

**3 Press Steps > Property > Others.**

**4 Press Enable to switch between Enabled and Disabled.**

The value switches between Enabled and Disabled each time that you press the key.

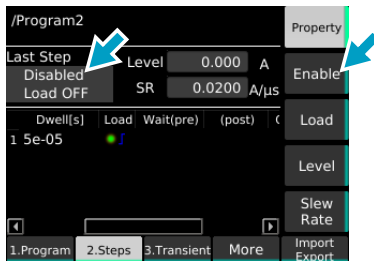

**5 If you select Enabled, set the load state at the end of the sequence.**

Purpose	Operation
Set load on or off.	Press Load to switch between Load ON and Load OFF. The value switches each time you press the key.
Set the load value.	Press level, and use the numeric keypad or the rotary knob to enter the load value.
Set the slew rate.	Press Slew Rate, and use the numeric keypad or the rotary knob to enter the slew rate.

This completes the setting.

## Changing a program name

- 1** Press **SEQUENCE** and then **Program**.
- 2** Use the rotary knob to select the program, and then press **Select**.  
A check mark appears to the left of the selected program name.

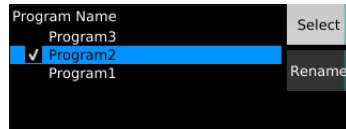

- 3** Press **Rename**.
- 4** Use the numeric keypad or the rotary knob to enter the program name, and then press **ENTER**.  
The program name is changed.

## Deleting a program

- 1** Press **SEQUENCE** and then **Program**.
- 2** Use the rotary knob to select the program, and then press **Delete**.  
If the check box of any program is selected, you cannot delete programs. If a check box is selected, use the rotary knob to select the corresponding program, and then press **Select** to clear the check box.

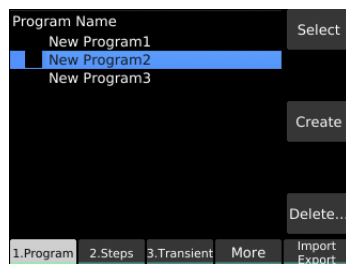

- 3** Use the rotary knob to select **OK**, and then press **ENTER**.  
The program is deleted.

# Setting Steps

## Creating steps

- 1 Press SEQUENCE and then Program.**
- 2 Use the rotary knob to select the program, and then press Select.**  
A check mark appears to the left of the selected program name.
- 3 Press Steps.**  
The step editing screen appears.  
If a new step editing screen is opened, the first step with the initial value is registered.

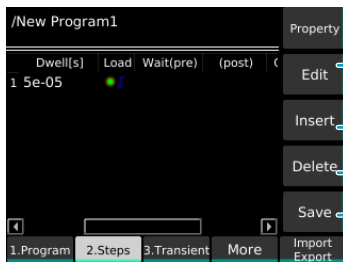

- Edit — Enables the editing of the settings of the selected step. Or confirms the settings.
- Insert — Adds a copy of the selected step below that step.
- Delete — Deletes the selected step.
- Save — Saves the edited step.

- 4 Use the rotary knob and the ◀/▶ keys to select a step and item, and then press Edit.**
- 5 Set the items.**  
Item(p.87): Level, SR, Dwell, Load, Wait (pre), Wait (post), Generate, →  
To confirm an item, press Edit again.
- 6 Repeat Step 4 and Step 5 until all the steps have been registered.**
- 7 Press Save.**  
The steps are registered to the program.

## Step settings

### ■ Level<sup>1</sup>

Use the numeric keypad or the rotary knob to set the load value of each operation mode. The value that you can set (unit: A, S, V, W) varies depending on the present operation mode.

- 1 This does not appear if the CC, CR, or CP external control is enabled in CC mode, CR mode, or CP mode or if the CV external control is enabled in CV mode.

### ■ SR

Use the numeric keypad or the rotary knob to set the slew rate.

### ■ Dwell

Use the numeric keypad or the rotary knob to set the step execution time. The values that you can set range from 0.000050 s to 3600000 s.

### ■ Load

Set the load state and the transition of the load value.

The load turns on and load off each time you press the Load sub-function key. If set to load on, press Immediate or Ramp to select the transition method.

Value	Description
Immediate (🟢⏏)	The load value transitions in steps from the value of the previous step.
Ramp (🟢📈)	The load value transitions with a slope from the value of the previous step. If the first step (step 1) is set to ramp, the start point of the load value is always 0 A, 0 S, 0 V, 0 W.

Example: Level: 10A, Dwell: 100 ms

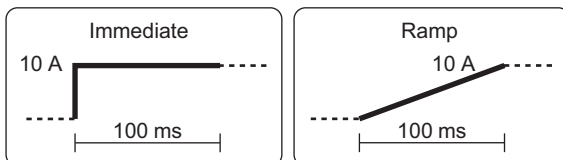

### ■ Wait (pre)

Set the pre-trigger source. If you set the pre-trigger source, the program pauses before executing a step. The pause is released when the specified trigger source condition is met.

Press MSync, Digital2, and BUS to turn each trigger source on or off. The value switches between on and off each time you press the key.

Trigger source	Description
MSync	Synchronizes the releasing of the paused state on synchronized PLZ12005WHs/ PLZ20005WHs (p.78).
Digital2 <sup>1</sup>	Releases the pause state when a signal is received at pin 13 of the EXT CONT connector.
BUS <sup>2</sup>	Releases the pause state when a *TRG command is received from a PC or the like.

- 1 Only when Direction of Digital 2 is set to Input (p.121).
- 2 If set to BUS, other trigger sources cannot be set.

■ Wait (post)

Set the post-trigger source. If you set the post-trigger source, the program pauses after executing a step. The pause is released when the specified trigger source condition is met.

Press Trig IN and Cutoff to turn each trigger source on or off. The value switches between on and off each time you press the key.

Trigger source	Description
Trig IN	Releases the pause state when a trigger is received (p. 118).
Cutoff	Releases the pause state when a cutoff is activated (p. 70).

■ Generate

Set the trigger signal output at the start of a step.

Press TA Link and Trig Out to turn each trigger output on or off. The value switches between on and off each time you press the key.

Value	Description
TA Link	A trigger is output at the start of a step. In the trigger setting (p.48) of the measurement function, setting Source to TA Link causes measurements to be recorded at the start of a step.
Trig Out	A 10 μs trigger signal is output from the TRIG OUT connector.

When Generate is set to Trig Out in step 2.

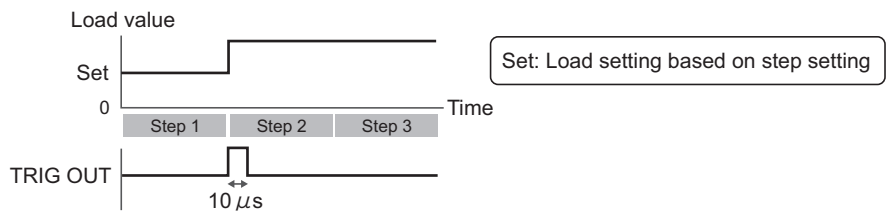

■ →

Set whether to set the EXT CONT connector pins (DIGITAL 0, 1, 2) to high level during a step.

Press Digital0, Digital1, and Digital2 to turn each item on or off. The value switches between on and off each time you press the key.

Value	Description
Digital0	Pin 11 (DIGITAL 0) of the EXT CONT connector is set to high level.
Digital1	Pin 12 (DIGITAL 1) of the EXT CONT connector is set to high level.
Digital2 <sup>1</sup>	Pin 13 (DIGITAL 2) of the EXT CONT connector is set to high level.

1. Only when Direction of Digital 2 is set to Output (p. 121).

Example: When → is set to Digital0 in step 2

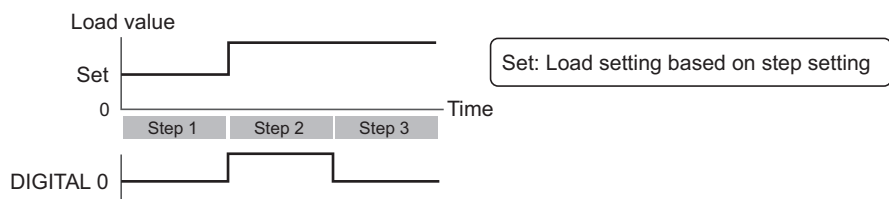



## Deleting steps

---

- 1 Press SEQUENCE and then Steps.**
- 2 Use the rotary knob to select the step, and then press Delete.**

The selected step is deleted.
- 3 Press Save.**

The program is updated.  
This completes the setting.

# Sequence creation tutorial

In this example, we will actually create a sequence from the front panel.

We will enter the following program in CC mode for the PLZ12005WH.

Program name: Program1, number of loops: 2

Run	Current	Execution time	Load	Transition	Trigger output
Step 1	8 A	10 seconds	On	Ramp	None
Step 2	6 A	12 seconds	On	Immediate	None
Step 3	0 A	7 seconds	Off	–	None
Step 4	3 A	15 seconds	On	Immediate	Trig Out

Program1 executes steps 1 to 4 and ends the first execution. When Program1 is executed one more time, this sequence is over.

Representing this sequence in graph form looks as follows.

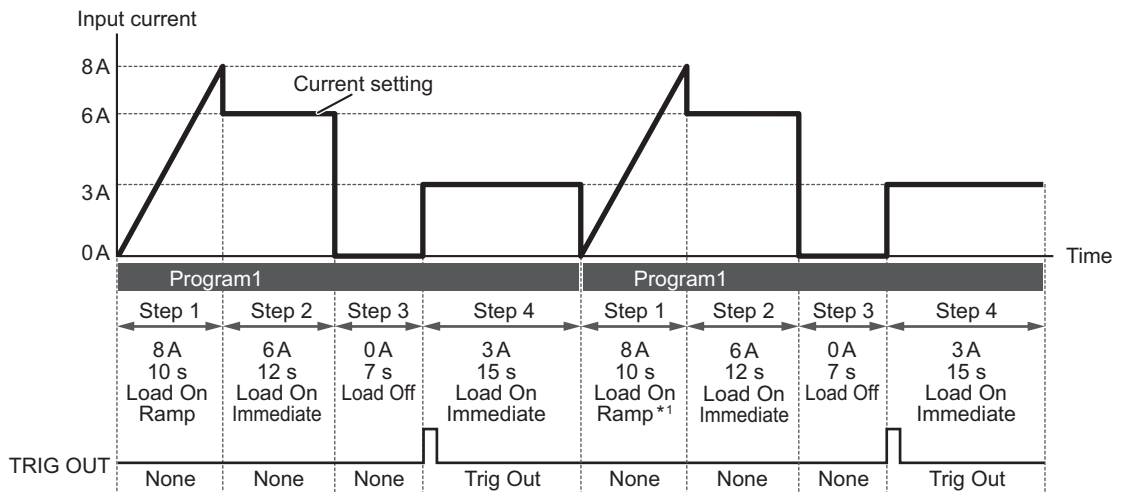

\*1 If Load of step 1 is set to Ramp and the program is repeated, the start current of step 1 will always be 0 A.

## Creating Program1 as a new program

- 1 Set the operation mode to CC (p.24).
- 2 Press SEQUENCE, Program, and then Create.
- 3 Use the numeric keypad or the rotary knob to enter program name "Program1", and then press ENTER.  
Program1 is created.

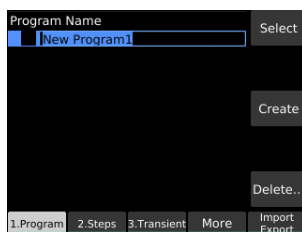

## Registering steps to Program1

When registering steps to a program, we recommend that you save the program after setting all the steps. There is no need to save a program after setting each step.

### Creating step 1

#### 1 Use the rotary knob to select Program1, and then press Select.

A check mark appears to the left of Program1.

#### 2 Press Steps and then Edit.

The Level (current) cell of step 1 becomes editable.

#### 3 Use the numeric keypad or the rotary knob to enter the current value "8", and then press Edit.

This sets the value to 8 A.

#### 4 Use the ► key to select a cell in the Dwell column, and then press Edit.

Dwell (execution time) becomes editable.

#### 5 Use the numeric keypad or the rotary knob to enter execution time "10", and then press Edit.

This sets the value to 10 s.

#### 6 Use the ► key to select a cell in the Load column, and then press Edit.

Load (load and transition) becomes editable.

#### 7 Press Ramp and then Edit.

 (load on, ramp transition) is set.  
Proceed to create step 2.

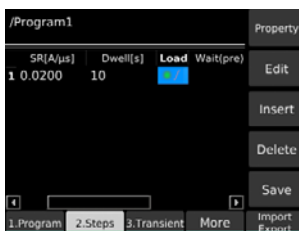

## Creating step 2

- 1 Press Insert.**  
Step 2 is inserted.
- 2 Use the ◀ key to select a cell in the Level column of Step 2 (row 2), and then press Edit.**
- 3 Set step 2 as follows: Level: 6, Dwell: 12, Load: On (Immediate).**  
The current is set to 6 A, the execution time to 12 s, and the load to on. Immediate transition is selected. Proceed to create step 3.

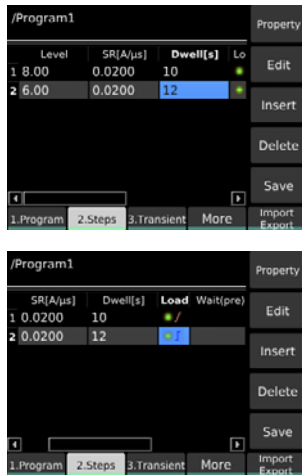

## Creating step 3

- 1 Press Insert.**  
Step 3 is inserted.
- 2 Use the ◀ key to select a cell in the Dwell column of Step 3 (row 3), and then press Edit.**
- 3 Set step 3 as follows: Dwell: 7, Load: Off (blank).**  
The execution time is set to 7 s and the load to off. Because the load is off in this step, there is no need to set the current. Proceed to create step 4.

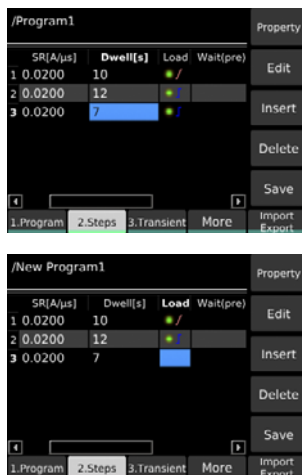

## Creating step 4

- 1 Press Insert.**  
Step 4 is inserted.
- 2 Use the ◀ key to select a cell in the Level column of Step 4 (row 4), and then press Edit.**
- 3 Set step 4 as follows: Level: 3, Dwell: 15, Load: On (Immediate).**  
The current is set to 3 A, the execution time to 15 s, and the load to on. Immediate transition is selected. Proceed to setting the number of loops.

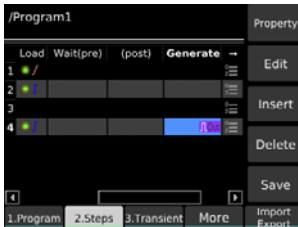

## Setting the number of loops

- 1 Press Property and then Loop.**
- 2 Use the numeric keypad or the rotary knob to enter number of loops “2.”**
- 3 Press Property.**  
The number of loops is set to 2. Proceed to saving Program1.

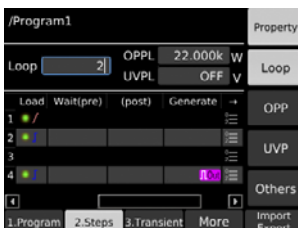

## Saving Program1

- 1 Press Save.**  
Program1 is saved.  
This completes the setting.

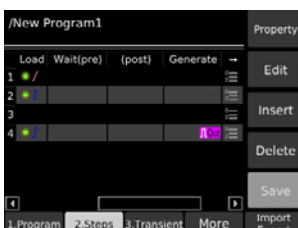

# Executing, Pausing, and Stopping Sequences

When you finish setting the program and steps, you can run the sequence. You can pause or stop the sequence while it is running. By setting triggers (p.95), you can control the timing at which sequences are to be started.

## Executing a sequence

- NOTE**
- During sequence execution, the pulse function and sine function are forcibly turned off.
  - During sequence execution, the specified cutoff functions (p.62) are enabled. Even if the load is turned off due to a cutoff activation during the execution of a step, if load on is specified in the next step, the cause of the activated cutoff is cleared, and the load is turned on again. The sequence continues to be executed.

The sequence can be executed regardless of whether the load is on or off.

- 1 Set the operation mode (p.23) according to the sequence to be executed.**
- 2 Press SEQUENCE and then Program.**
- 3 Use the rotary knob to select the program, and then press Select.**  
A check mark appears to the left of the program name.
- 4 Press Transient and then Initiate.**

The sequence is executed, and the measurements and  appear on the display.

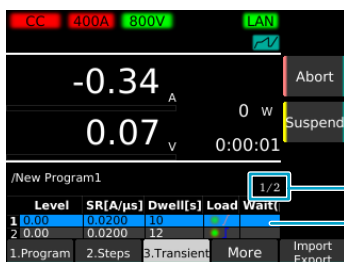

Number of running loops/total number of loops

The running step is highlighted in blue.

## Synchronizing the start timing of sequences

The start timing of sequences can be synchronized on synchronized PLZ12005WHs/PLZ20005WHs. For details, see “Synchronizing the start of sequences” (p.77).

## Aborting a sequence

Pressing Abort during sequence execution stops the sequence execution in progress (if the load is on, it remains on).

## Pausing a sequence

### 1 Press Suspend during sequence execution.

The sequence is paused (figure below). Press Resume to resume the sequence.

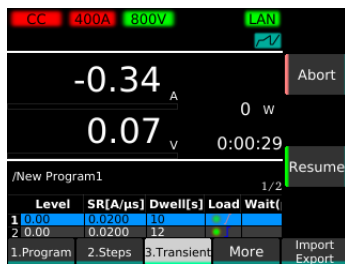

## Controlling the start of sequences with triggers

By setting triggers, you can control the timing at which sequences are to be started. The triggers that you can set are as follows:

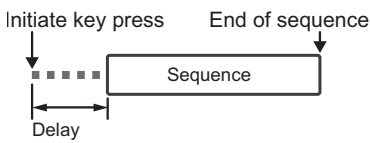
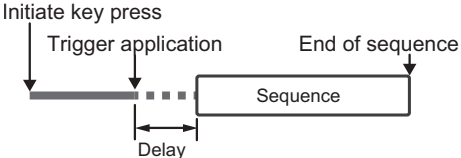
Item	Value	Description
Trigger	—	Sets the trigger.
Source	—	Event (trigger source) that will be used as a condition for starting sequences. Sequence starts after the Initiate key is pressed and a trigger is received.
Immediate (factory default)		Pressing Initiate without waiting for a trigger signal applies a trigger immediately. 
BUS		Applies a trigger when a *TRG command is received from a PC or the like.
DIGITAL2 <sup>1</sup>		Applies a trigger when a signal is received at pin 13 of the EXT CONT connector. 
MSync		The trigger application timing is synced between the PLZ12005WHs/ PLZ20005WHs that are synchronized (p.77).
Delay	0 s to 100 s	Set the delay time from trigger application until the start of sequence. The factory default setting is 0 s.

1. Only when Direction of Digital 2 is set to Input (p.121).

■ **Trigger processing procedure**

The general trigger processing procedure is illustrated in the following figures.

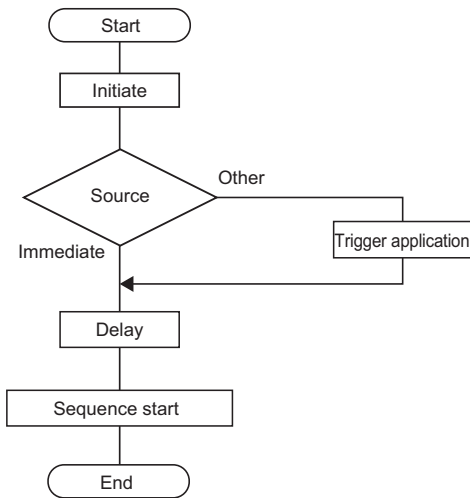

- 1** Press **SEQUENCE > More**.
- 2** Use the rotary knob to select the trigger ([p.95](#)), and then press **Edit**.

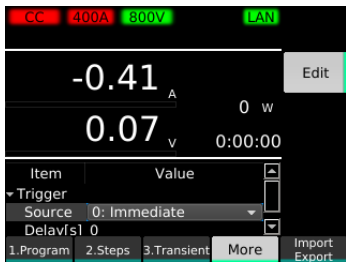

- 3** Use the rotary knob or numeric keys to perform input, and then press **ENTER**.  
Repeat steps Step 2 and Step 3 to set triggers.  
This completes the setting.



# Exporting and Importing Programs

Programs saved in the internal memory can be exported to a USB memory device. Programs exported to a USB memory device can also be imported into the internal memory.

- 1** Insert a USB memory device into the USB port on the front panel.
- 2** Press **SEQUENCE > Import/Export**.  
An Import/Export screen appears.

## ■ Basic operations on the Import/Export screen

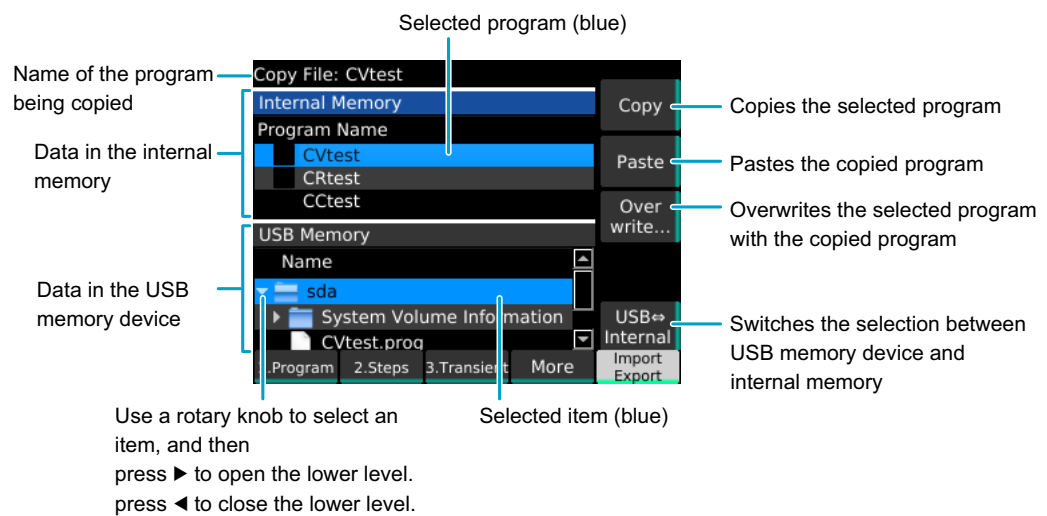

## Exporting programs to a USB memory device

- 1** On the Import/Export screen, press **USB ↔ Internal**, and select **“Internal Memory,”** which is at the top of the display area.  
Each time you press USB ↔ Internal, the selection toggles between USB Memory and Internal Memory.
- 2** Use the rotary knob to select the program to export, and then press **Copy**.  
Exporting is not possible for programs with a check mark to the left of the program name. Displaying the program editing screen (p. 81) and selecting a program with a check mark using the rotary knob clears the check box.
- 3** Press **USB ↔ Internal**.  
“USB Memory,” which is at the bottom of the display area, is selected.
- 4** Use the rotary knob to select the export location, and press **Paste**.  
To overwrite the selected file, press Overwrite.  
A file named “program name”.prog is saved at the specified location.

## Importing programs from a USB memory device

---

- 1 On the Import/Export screen (p. 97), press USB↔Internal, and select “USB Memory,” which is at the bottom of the display area.**

Each time you press USB↔Internal, the selection toggles between USB Memory and Internal Memory.

- 2 Use the rotary knob to select the program to import, and then press Copy.**

- 3 Press USB↔Internal.**

“Internal Memory,” which is at the top of the display area, is selected.

- 4 Use the rotary knob to select the import location, and press Paste.**

To overwrite the selected memory area, press Overwrite.

The program is saved to the internal memory.

# External Control

## Preparation for External Control

The product can be controlled and monitored from an external device.

The external control terminals are isolated from the load input terminals. Moreover, the BNC connectors (V MON OUT, I MON OUT, TRIG OUT) are isolated from the chassis.

Control	Functions that can be controlled/monitored	Connector
Analog control	Controlling the load values of CC, CP, CR, and CV modes using voltage. Controlling the current to be superimposed on the load values of CC mode using voltage.	EXT CONT
Digital control	Load on/off control Sequence and measurement triggers Releasing a paused sequence Activation of an alarm Clearing an alarm state	EXT CONT
Signal output	Monitoring of the load on/off state	EXT CONT
	Monitoring of the alarm state	EXT CONT
	Monitoring of the sequence step period	EXT CONT
	Monitoring of the current (I MON OUT)	BNC/EXT CONT
	Monitoring of the voltage (V MON OUT)	BNC
	Pulse and sequence trigger output (TRIG OUT)	BNC

## Precautions for use at high response speeds

When the product is used at a high response speed, do not connect the common terminal of the external device to the terminal of the DUT (the terminal that is connected to the negative (-) input terminal of the product). Attach a commercially available ferrite core to the wiring between the product and the external device.

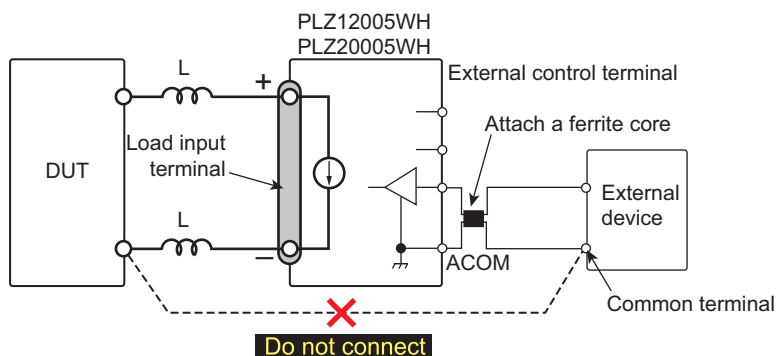

## EXT CONT connector pin arrangement

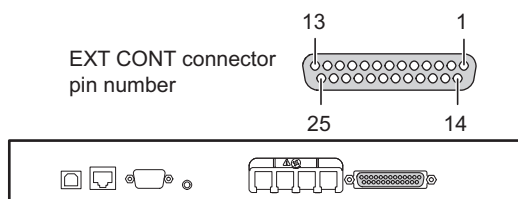

Pin no.	In/Out <sup>1</sup>	Signal name	Description
1	—	STATUS COM	Status signal common for pins 2, 3, 14 to 16.
2	NC	—	—
3	NC	—	—
4	NC	—	—
5	IN	ALARM CLEAR	Alarm clearing input (p.107).
6	IN	ALARM INPUT	Alarm input (p.107).
7	NC	—	—
8	NC	—	—
9	IN	TRIG INPUT	Trigger input. Resumes program execution if Wait(post) was set to Trig IN in a sequence step and the program was paused (p.108).
10	—	A COM	Connected to the chassis.
11	OUT	DIGITAL 0	DIGITAL0 output (p.109). Sequence control possible.
12	OUT	DIGITAL 1	DIGITAL1 output (p.109). Sequence control possible.
13	IN/OUT	DIGITAL 2	DIGITAL2 I/O (p.109). Input/output switchable (p.121). Sequence signal output or the trigger input of sequences and measurement function.
14	OUT	ALARM1	ALARM1 output (p.107). ON when overvoltage detection, reverse-connection detection, overheat detection, alarm input detection, or parallel operation anomaly detection is activated, and also during external alarm input.
15	OUT	ALARM2	ALARM2 output (p.107). ON during OCP, OPP, UVP, or WDP operation.
16	OUT	LOAD ON STATUS	Load-on status output (p.106). ON during load on.
17	NC	—	—
18	IN	LOAD ON/OFF CONT	Load on/off control input (p.105). Logic level switchable.
19	—	A COM	Connected to the chassis.
20	IN	EXT CONT ADD	External voltage control input (p.104). Controls the load setting of CC mode by adding current.
21	IN	EXT CONT MODE	External voltage control input (p.102). Controls the load values of CC, CR, and CP modes.
22	IN	EXT CONT CV	External voltage control input (p.103). Controls the voltage of CV mode.
23	—	A COM	Connected to the chassis.
24	OUT	IMON	Current monitor output (p.110).
25	—	N.C.	—

1. 800 V reinforced insulation between each pin and load input terminals

### Storing the protection plate

By factory default, the protection plate is mounted on the EXT CONT connector. When using the EXT CONT connector, keep the removed protection plate in a safe place. When the connector is not in use, for safety and for preventing electric disturbance, be sure to attach the protection plate that comes with the product. If it is damaged or lost, contact your Kikusui agent or distributor.

## Connecting to the EXT CONT connector

### NOTE

- To prevent noise interference, use twisted wires for the signal cables.
- Use a highly stable external voltage that has low noise.

### External control connector kit

To connect the signal cable to the EXT CONT connector, use the external control connector kit that comes with the product. For information about how to use this kit, see the TE Connectivity (formerly AMP) catalog. For information about how to obtain these tools or replacement parts, contact your Kikusui agent or distributor.

Connector model (on the product)	5747461-3 [made by TE Connectivity]
Plug model	745211-7 [made by TE Connectivity]
Wire diameter	AWG26 to AWG22
Manual pressure welding tool	Handle assembly 58074-1 [made by TE Connectivity] Head assembly 58063-2 [made by TE Connectivity]
Insertion/extraction tool	91232-1 [made by TE Connectivity] or equivalent

### Connecting the signal cable

- 1 Turn the POWER switch off.
- 2 Remove the protection plate of the EXT CONT connector.

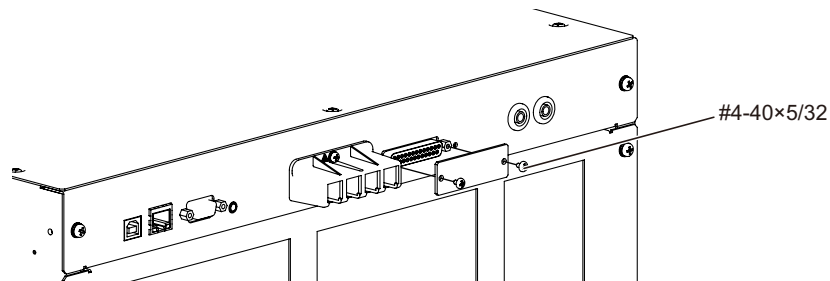

- 3 Connect the signal cable to the EXT CONT connector.

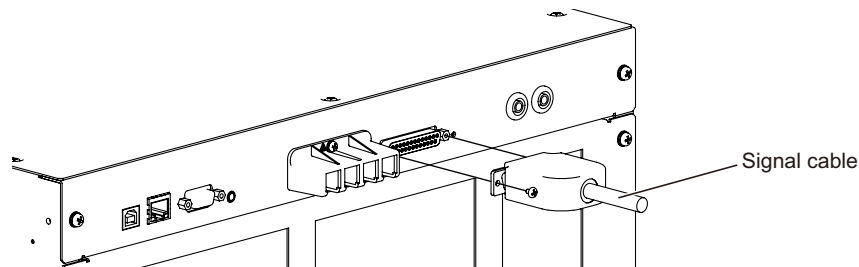

- 4 Connect the signal cable to the external controller.  
This completes the external control connection procedure.

# Load Setting Control

## Constant current (CC), constant resistance (CR), and constant power (CP) control

You can control the load values (current, conductance, power) of CC, CR, and CP modes using external voltage. When you apply an external voltage between 0 V to 10 V to the EXT CONT connector, a load setting proportional to the change can be obtained.

An external voltage of 0 V results in a load setting that is 0 % of the rating, and an external voltage of 10 V in a load setting that is 100 % of the rating. The accuracy cannot be guaranteed when the external voltage is less than 0 V or more than 10 V.

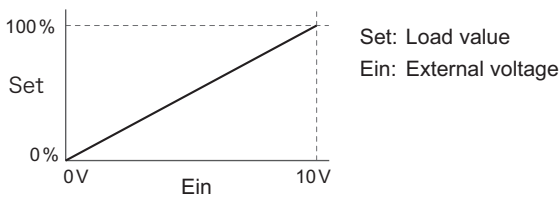

### ⚠ CAUTION

To avoid damaging the product, observe the following precautions.

- The maximum voltage that can be applied across pins 21 and 23 of the EXT CONT connector is  $\pm 11$  V. Do not apply a voltage that exceeds this.

- 1 Turn the **POWER** switch off.
- 2 Connect an external voltage across pins 21 and 23 of the EXT CONT connector.

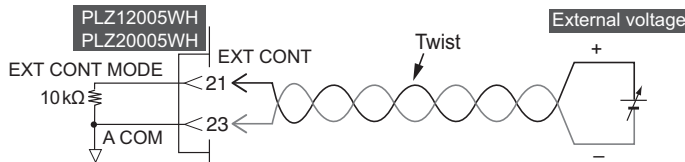

- 3 Turn the **POWER** switch on and check that the load is off.
- 4 Set the operation mode to **CC**, **CR**, or **CP**.
- 5 Press **SOURCE** and then **More**.
- 6 Use the rotary knob to select **CC**, **CR**, or **CP** under **External Control**, and then press the **Edit** key.
- 7 Use the rotary knob to select **Enable**, and then press **ENTER**.

External control of each mode becomes possible. If **Disable** is selected, external control is disabled.

This completes the setting.

## Constant voltage (CV) control

You can control the voltage in CV mode with an external voltage. When you apply an external voltage of 0 V to 10 V to the EXT CONT connector, the voltage varies proportionally to that external voltage.

An external voltage of 0 V results in voltage of 0 V. An external voltage of 10 V results in voltage at 100 % of the rating. The accuracy cannot be guaranteed when the external voltage is less than 0 V or more than 10 V.

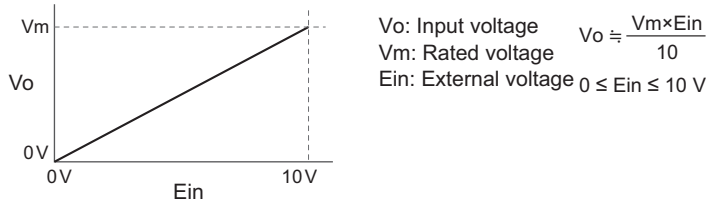

### ⚠ CAUTION

To avoid damaging the product, observe the following precautions.

- Do not apply a voltage outside  $\pm 11 \text{ V}$  across pins 22 and 23 of the EXT CONT connector.

- 1 Turn the **POWER** switch off.
- 2 Connect an external voltage across pins 22 and 23 of the EXT CONT connector.

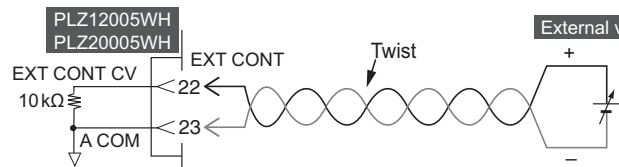

- 3 Turn the **POWER** switch on and check that the load is off.
- 4 Set the operation mode to **CV**.
- 5 Press **SOURCE** and then **More**.
- 6 Use the rotary knob to select **CV** under External Control, and then press the **Edit** key.
- 7 Use the rotary knob to select **Enable**, and then press **ENTER**.

External voltage control of CV mode is now possible. If Disable is selected, external control is disabled.

This completes the setting.

### NOTE

If CV is selected under External Control, the UVP action is set to UVP Limit (p.44). You cannot select the UVP Trip action.

## Controlling the current to be superimposed on the constant current (CC)

You can control the current to be superimposed to the current value of CC mode with an external voltage. When you apply an external voltage between 0 V to 10 V to the EXT CONT connector, the load current becomes the sum of the current proportional to the external voltage change and the Present current setting.

When you apply an external voltage between -10 V to 0 V to the EXT CONT connector, the load current is equal to the current that is proportional to the external voltage change subtracted from the present current setting.

If the current setting is  $I_s$  (figure below), the current that is added to the current setting for an external voltage of 0 V is 0 A. The current that is added to the current setting for an external voltage of  $\pm 10$  V is 100 % of the rating. However, the final load current range is 0 A to 100 % of the rating.

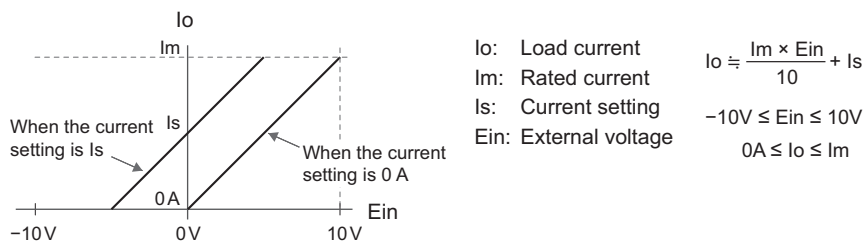

### ⚠ CAUTION

To avoid damaging the product, observe the following precautions.

- Do not apply a voltage outside  $\pm 11$  V across pins 19 and 20 of the EXT CONT connector.

- 1 Turn the POWER switch off.
- 2 Connect an external voltage across pins 19 and 20 of the EXT CONT connector.

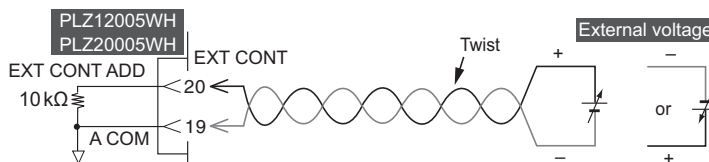

- 3 Turn the POWER switch on and check that the load is off.
- 4 Set the operation mode to CC.
- 5 Press SOURCE and then More.
- 6 Use the rotary knob to select CC Add under External Control, and then press Edit.
- 7 Use the rotary knob to select Enable, and then press ENTER.

External control of superimposing in CC mode is now possible. If Disable is selected, external control is disabled.

This completes the setting.



# Controlling Load On/Off

You can control load on/off with an external signal. You can also monitor the load on/off state.

## Priority relationship between the operation of the external contact and the operation of the LOAD key on the front panel

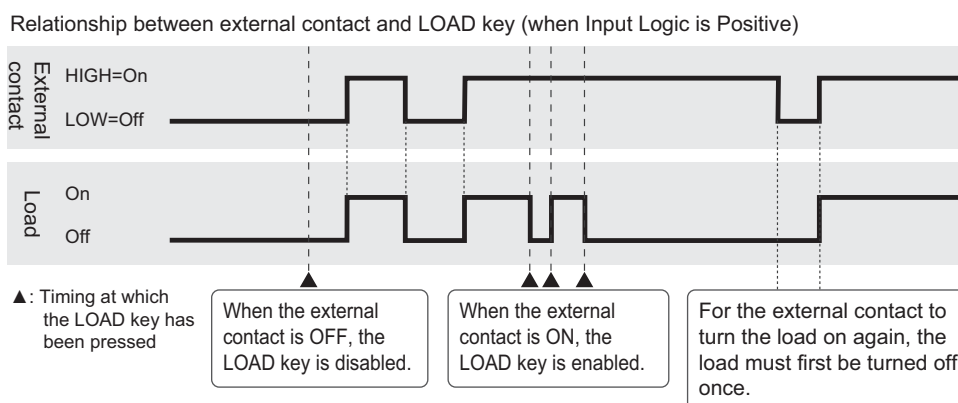

The OUPP command during remote control is equivalent to the LOAD key.

## Load on/off control input

- 1 Turn the POWER switch off.
- 2 Connect an external contact across pins 18 and 19 of the EXT CONT connector.

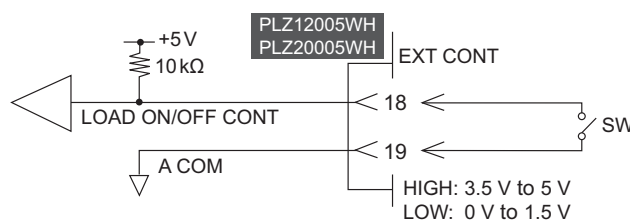

- 3 Press SOURCE and then More.
- 4 Use the rotary knob to select Input Logic under External Control, and then press Edit.
- 5 Use the rotary knob to select the item, and then press ENTER.

Item	Description
Positive	Opening and closing the external contact turns the load on and off, respectively.
Negative	Opening and closing the external contact turns the load off and on, respectively.



External control of load on/load off is now possible.

This completes the setting.

### Load on/off control state display

The external contact input logic setting and state of load on/off control are displayed with icons in the top area of the display.

For example, if the external contact input logic setting is positive and the state is low, you cannot turn the load on by pressing LOAD. In this situation, you can check the external contact input logic setting and state by referring to the icons in the following table (p. 10).

Icon	External contact state	External contact input logic setting (Input Logic)
Not shown	High	Positive
	Low	Positive
	High	Negative
	Low	Negative

### Load-on status signal output

To externally monitor the load on/load off state, use pin 16 of the EXT CONT connector. Use pin 1 as the common.

Maximum applied voltage: 30 V

Maximum current: 4 mA

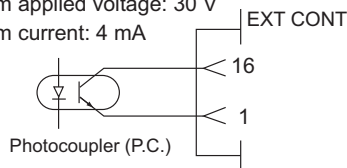

	Load on	Load off
Photocoupler	ON	OFF

# Controlling Alarms

You can use an external control signal to activate the product's alarm. You can also monitor alarm occurrences.

## Alarm input

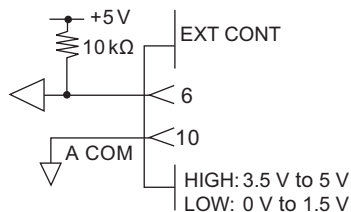

Use pin 6 of the EXT CONT connector. Use pin 10 as the common. An alarm is activated and the load is turned off when the input to pin 6 is a low level signal.

## Alarm clearing input

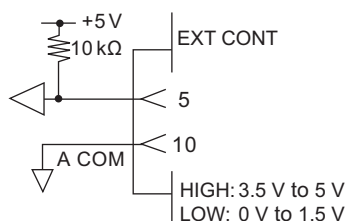

Use pin 5 of the EXT CONT connector. Use pin 10 as the common. After an alarm occurs, eliminate the root cause of the alarm, and change the input to pin 5 of the EXT CONT connector from a low level signal to a high level signal. The alarm will be cleared on the rising edge of this signal.

## Alarm status output

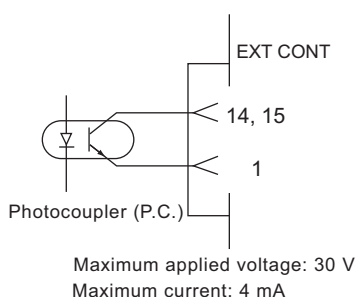

Use pin 14 (ALARM1) and pin 15 (ALARM2) of the EXT CONT connector. Use pin 1 as the common.

Pin 14 turns on when alarm 1 ([p.40](#)) is activated. Pin 15 turns on when alarm 2 ([p.41](#)) is activated.

# Trigger Input/Output

There is a trigger output connector (TRIG OUT) on the front panel, and a trigger input connector (EXT CONT pin 9) on the rear panel.

## Trigger input

When Wait (post) is set to Trig IN in a sequence step setting (p.86), the sequence is paused at the end of the step. In this case, when the signal input to TRIG INPUT (pin 9) of the EXT CONT connector changes from high to low level, the pause is released at the falling edge of that signal.

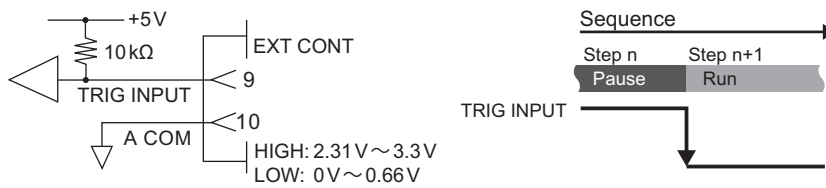

## Trigger output

The trigger signal is output under the following conditions.

Conditions	Pulse width
During pulse operation (p.34) and during sine operation (p.37)	10 μs
When a step for which Trig Output has been set is executed during sequence operation (p.88).	

The trigger signal is output from the TRIG OUT connector (BNC connector) on the front panel. The voltage level of the trigger signal output is HIGH: 4.2 V to 5.0 V, LOW: 0 V to 0.4 V, and the output impedance is approximately 200 Ω. The isolation voltage between the BNC connectors and chassis is ±30 V. The rated voltage between BNC connectors and load input terminals is ±800 V. The TRIG OUT connector is isolated from the chassis and load input terminal (A COM).

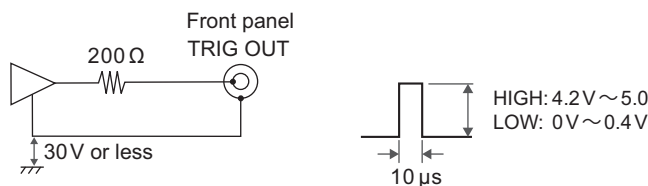

**NOTE**

- When the product is shipped from the factory, a plastic cover is attached to the TRIG OUT BNC connector. Keep the connector cover that you remove in a safe place. If you are not using the BNC connector, attach the connector cover for your safety and to prevent external disturbances.
- Use an insulated cable to connect to the BNC connector.

# Digital I/O

The rear-panel EXT CONT connectors include digital outputs DIGITAL0 (pin 11), DIGITAL1 (pin 12), and DIGITAL2 (pin 13) and digital input DIGITAL2 (pin 13). The input and output of DIGITAL2 can be switched (p. 121). Digital output is set to high level during a sequence step period. Digital input is used as a trigger input for sequence and measurement functions.

■ DIGITAL0, DIGITAL1, DIGITAL2 (output)

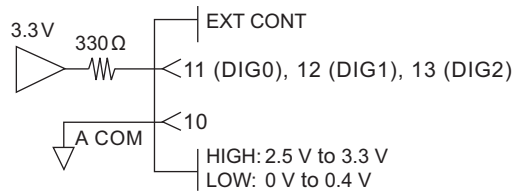

■ DIGITAL2 (input)

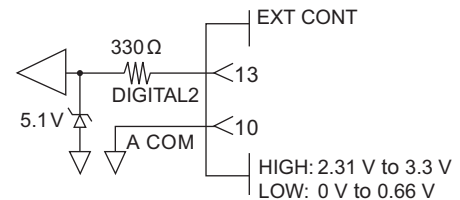

**NOTE**

The DIGITAL2 I/O terminal is not pulled up or down. If you set DIGITAL2 to input, do not leave the terminal open but rather set the terminal voltage to high or low within the input voltage range shown in the figure above.

# Current and Voltage Monitor Signals

## Current monitor and voltage monitor outputs

You can monitor the voltage and current by using the monitor signal outputs on the front panel. The current monitor signal is output from I MON OUT and across pins 23 and 24 (pin 23 is common) of the EXT CONT connector. The voltage monitor signal is output from V MON OUT (p.8).

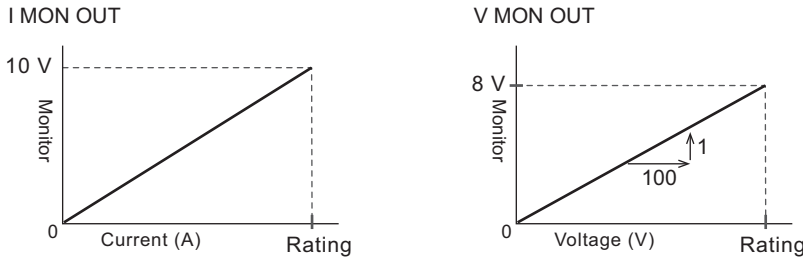

### I MON OUT and V MON OUT (BNC connectors)

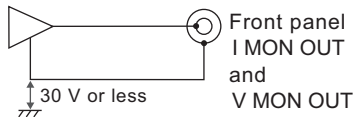

	I MON OUT	V MON OUT
Output voltage	Outputs 0 V to 10 V for 0 % to 100 % of rated current	Outputs 1/100 of the measured voltage in the 0 V to 8 V range
Maximum output current	5 mA	
Accuracy	±(1 % of range)	
Output impedance	50 Ω	
Isolation voltage	±30 V	

**NOTE**

- When the product is shipped from the factory, plastic covers are attached to the I MON OUT and V MON OUT BNC connectors. Keep the connector cover that you remove in a safe place. If you are not using the BNC connector, attach the connector cover for your safety and to prevent external disturbances.
- Use an insulated cable to connect to the BNC connector.

### Current monitor output (across pins 23 and 24 of the EXT CONT connector)

The current monitor output is 10 V at the rated current. The common is connected to A COM. The output impedance is 1 kΩ.

# Parallel Operation

## Overview of Parallel Operation

The PLZ-5WH series or Kikusui Electronic Load PLZ-5WH2 series can be connected in parallel to increase the total current and power capacities. The included or optional (p. 163) parallel operation signal cable kit is required for parallel connection.

You can control up to four slave units from a master unit. Parallel operation is also possible among models with different power capacities. The master unit and the slave units are automatically configured according to the connection status. The master unit displays the total current and total power for all the electronic loads that are connected in parallel.

Parallel operation is possible by mixing PLZ-5WHs and PLZ-5WH2s, but when a PLZ-5WH2 is made the master unit, PLZ-5WHs cannot be connected as slave units.

### NOTE

- During parallel operation, the product may not meet the specifications that it has during independent operation. The setting accuracy and measurement accuracy can be improved by performing calibration in a parallel state. To have your product calibrated, contact your Kikusui agent or distributor.
- The setting resolution during parallel operation varies depending on the number of units in parallel operation.

### ■ Connection example

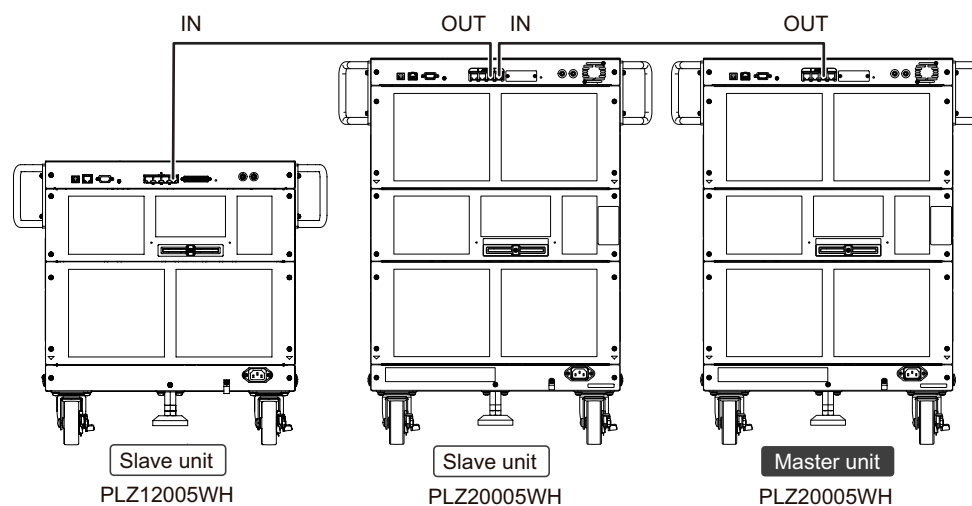

### ■ Maximum current and maximum power during parallel operation (when the models are all the same)

Number of slaves	Maximum current / Maximum power	
	PLZ12005WH	PLZ20005WH
1	480 A/24 kW	800 A/40 kW
2	720 A/36 kW	1 200 A/60 kW
3	960 A/48 kW	1 600 A/80 kW
4	1 200 A/60 kW	2 000 A/100 kW

## Making connections for parallel operation

Connect the electronic loads to be operated in parallel to the DUT, and connect each unit using parallel operation signal cables.

**⚠ WARNING** Using improper cables may cause fire. Use load cables with a core diameter that is appropriate for the amount of current being used and with sturdy, flame-resistant insulation.

**⚠ CAUTION** To avoid damaging the product, observe the following precautions.

- Do not connect the PARALLEL connector's IN and OUT terminals incorrectly.
- Do not leave one end of the parallel operation signal cable connected to the PARALLEL connector when the other end is not connected.

**1** Turn the load off of all the electronic loads to be connected in parallel.

**2** Connect the load input terminals of each unit to the DUT.

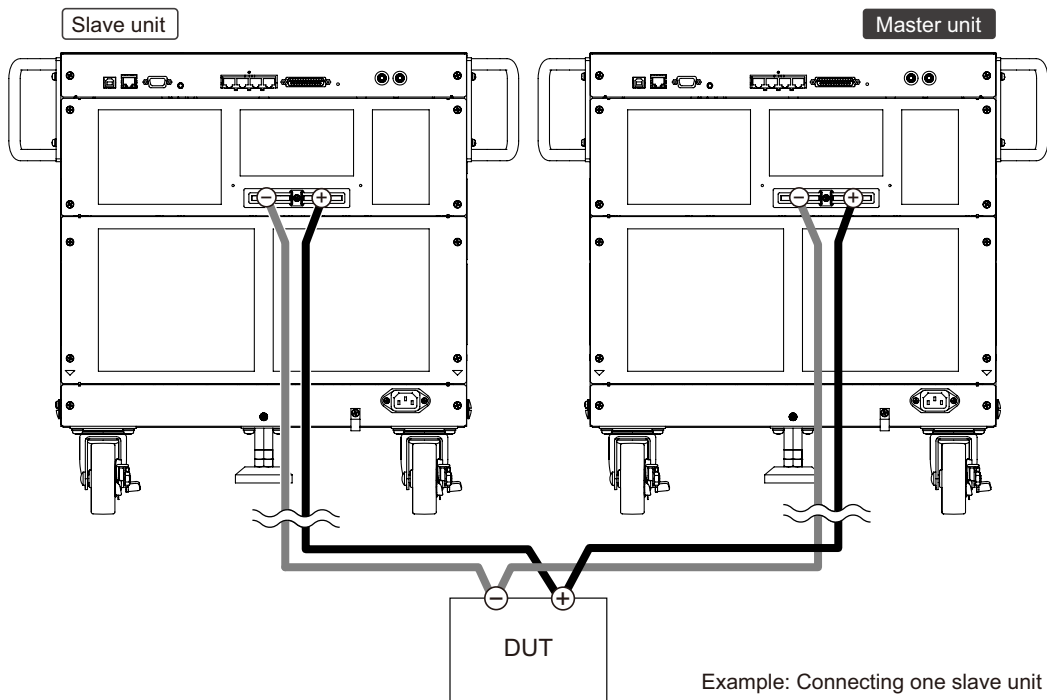

Securely connect the load input terminals of multiple units to each other in parallel. After making the connections, attach the load input terminal covers (p. 15).

- Use load cables that are as short as possible and have sufficient thickness for the current to be used.
- Route the load cables as far as possible from the signal cables.
- Use load cables that are all of the same length (equalize the voltage drop in the load cables).



**3** Remove the SYNC/PARALLEL port cover.

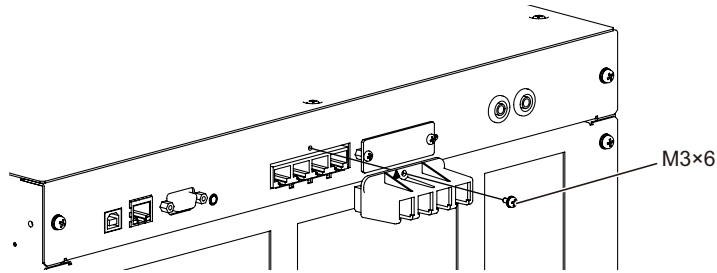

**4** Connect all the electronic loads to be operated in parallel with parallel operation signal cables.

Connect the PARALLEL OUT connector and IN connector with a parallel operation signal cable.

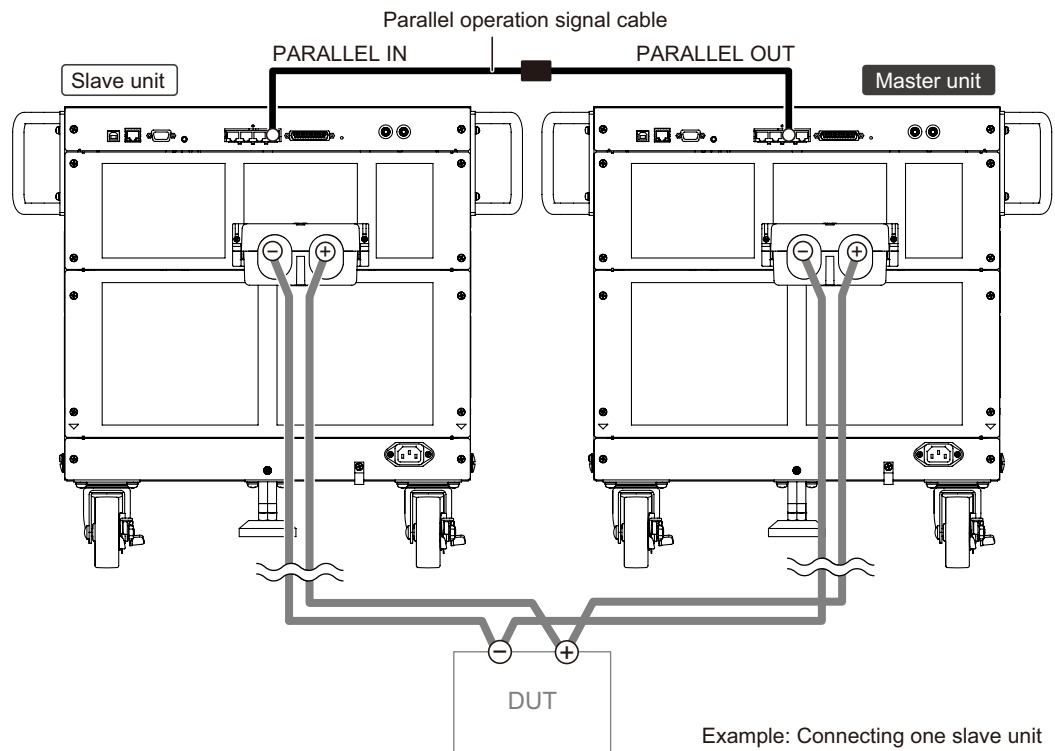

**5** Attach the SYNC/PARALLEL port cover.

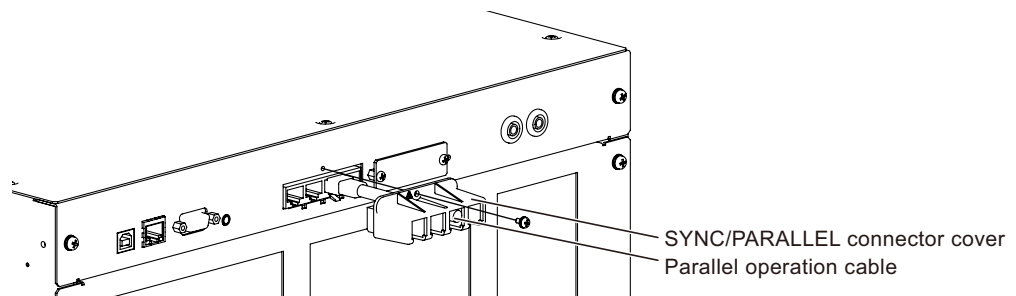

This completes the connections.

## Performing parallel operation

Once a parallel connection is made, the master unit and slave units are automatically identified, so parallel operation can be used immediately.

For the operating range, see the appendix (p.162).

### Power on and off

You can turn the POWER switches of all the electronic loads on or off in any order.

## Slew rate and response speed settings during parallel operation

During parallel operation, the slew rate and response speed settings on the master unit are used. The slew rate increases proportionally to the number of units operating in parallel. For details, see “Slew rate during parallel operation” (p.162).

In the following cases, set the response speed (p.57) to Normal to ensure stable operation.

- If the inductance of the wiring will be increased and large voltage drops will occur owing to current changes.
- If control of the electronic loads may become unstable and oscillation phenomena may occur owing to phase lag of the current.

## Protection function during parallel operation (parallel operation anomaly detection)

When an anomaly occurs during parallel operation, the following alarms appear on the displays of the master and slave units, and the loads are turned off. Eliminate the root cause of the alarm, and then clear the alarm.

Display	Applicable unit	Activation condition	Clearing method
Parallel Communication Alarm	Master unit	A communication anomaly was detected during parallel operation.	Restart <sup>1</sup>
Parallel Slave Over Temperature Alarm	Master unit	An overheating of a slave unit was detected.	Press ENTER on the master unit.
OTP/Front Alarm	Slave unit	An overheating of master unit was detected.	Press ENTER on the master unit.
AC Fail Alarm	Master unit	A slave unit's power supply was interrupted.	Restart <sup>1</sup>
Parallel Master Lost Alarm	Slave unit	The master unit cannot be detected.	Restart <sup>1</sup>
Alarm	Slave unit	An alarm of another unit was detected.	Press ENTER on the master unit.
Incorrect Slave Alarm	Master unit	A Kikusui PLZ-5W series <sup>2</sup> electronic load was connected to a slave unit.	Restart <sup>1</sup>

1. Turn the POWER switches of all the electronic loads off and then on in any order.
2. PLZ205W, PLZ405W, PLZ1205W, or PLZ2405WB.

## Changing from parallel operation back to standalone operation

---

Turn off all the units connected for parallel operation, and then remove all connections for parallel operation. Then, connect for standalone operation.

---

 **CAUTION**

To avoid damaging the product, observe the following precautions. Do not perform standalone operation with the parallel operation signal cable left connected to the PARALLEL connector.

---

# System Settings

## Displaying and Changing CONFIG Settings

You can set the following parameters using the CONFIG settings.

Parameter	Value <sup>1</sup>	Description
Remote Sensing	<u>Enable/Disable</u>	Remote sensing ( <a href="#">p.61</a> ).
Power On	<u>RST/RCL0/Resume</u>	Panel settings at startup ( <a href="#">p.117</a> ).
Watchdog	<u>Enable/Disable</u>	Watchdog protection setting ( <a href="#">p.45</a> ).
Delay	1 second to 3600 seconds (1 second unit) Factory default is 60 seconds.	Time until watchdog times out.
Screen Saver	<u>Enable/Disable</u>	Screen saver ( <a href="#">p.118</a> ).
Delay	60 seconds to 59940 seconds (after setting, rounded to nearest second unit) Factory default is 60 seconds.	Time until the screen saver starts.
Key	<u>Enable/Disable</u>	Key lock ( <a href="#">p.119</a> ).
Lock Level	<u>Low/Medium/High</u>	Key lock level ( <a href="#">p.119</a> ).
Beeper	—	Beep sound setting ( <a href="#">p.120</a> ).
Key	<u>Enable/Disable</u>	Beep sound for invalid operation.
Protection	<u>Enable/Disable</u>	Beep sound for alarm occurrence.
SCPI	<u>Enable/Disable</u>	Beep sound for SCPI errors.
Digital2	—	—
Direction	<u>Input/Output</u>	I/O direction of DIGITAL2 signal ( <a href="#">p.121</a> ).

1. Factory default settings are underlined.

### Remote sensing

You can enable or disable remote sensing. For details on remote sensing, see “Remote Sensing” ([p.59](#)).

## Panel settings at startup

The panel setting state at power-on can be selected.

### 1 Press SYSTEM.

If the Configure screen does not appear, press Configure.

### 2 Use the rotary knob to select Power on, and then press Edit.

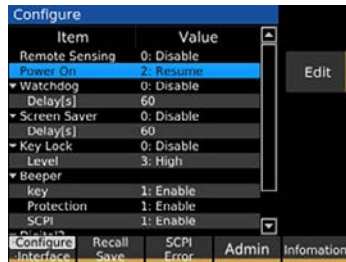

### 3 Use the rotary knob to select the following items.

Parameter	Description
RST	Start with the reset settings ( <a href="#">p.129</a> ).
RCL0	Start in setup memory ( <a href="#">p.70</a> ) 0 condition.
Resume	Start with the same settings as when the power was switched off the previous time (but always load off).

### 4 Press ENTER.

This completes the setting.

## Watchdog protection setting (WDP)

You can enable or disable WDP and set the WDP value. For details on WDP, see “Setting watchdog protection (WDP)” ([p.45](#)).

## Screen saver

The screen saver starts and the display dims when there is no panel activity for a specified length of time. Set the time until the screen saver starts.

### 1 Press SYSTEM.

If the Configure screen does not appear, press Configure.

### 2 Use the rotary knob to select Screen Saver, and then press Edit.

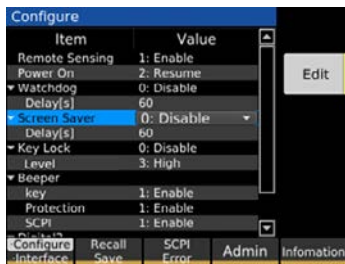

### 3 Use the rotary knob to select Enable, and then press ENTER.

Selecting Disable disables the function.

### 4 Use the rotary knob to select Delay, and then press Edit.

### 5 Use the numeric keypad or the rotary knob to set the time until the screen saver is activated, and press ENTER.



This completes the setting.

## Key lock

The keys can be locked to prevent changing the settings or overwriting memory or sequences by mistake.

### Setting the key lock level

You can set three different key lock levels according to the type of keys whose operation is prohibited. While key lock is enabled, an icon is shown in the top area of the display depending on the key lock level. While the keys are locked, you cannot switch to the Configure screen. To set the key lock level, release the key lock in advance.

Level	Description	Icon
1:Low	Locks all operations except the following. <ul style="list-style-type: none"> <li>• Release key lock</li> <li>• Load on/off</li> <li>• Used to recall setup memory.</li> <li>• ABC preset memory recall</li> </ul>	
2:Medium	Locks all operations except the following. <ul style="list-style-type: none"> <li>• Release key lock</li> <li>• Load on/off</li> </ul>	
3:High	All key operations are locked except key lock release.	

#### 1 Press SYSTEM.

If the Configure screen does not appear, press Configure.

#### 2 Use the rotary knob to select Level under Key Lock, and then press Edit.

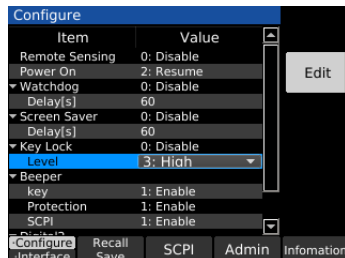

#### 3 Use the rotary knob to select the key lock level.

#### 4 Press ENTER.

This completes the setting.

## Enabling the key lock from the SYSTEM screen

- 1 Press SYSTEM.**  
If the Configure screen does not appear, press Configure.
- 2 Use the rotary knob to select Key Lock, and then press Edit.**
- 3 Use the rotary knob to select Enable, and then press ENTER.**  
Key lock is enabled.  
To clear the key lock, hold down ENTER on the front panel.

## Enabling or disabling the key lock from the front panel

- 1 Hold down KEY LOCK.**  
Each time KEY LOCK is held down, key lock is enabled or disabled.

## Setting the beep sound

You can enable or disable beep sounds that are emitted in case of invalid operation, alarm occurrence, or SCPI error.

- 1 Press SYSTEM.**  
If the Configure screen does not appear, press Configure.
- 2 Use the rotary knob to select the following items under Beeper, and then press Edit.**

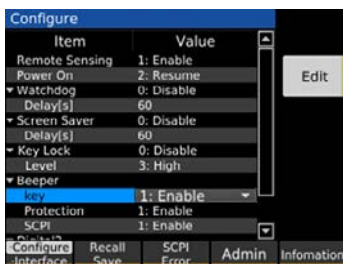

Parameter	Description
Key	Beep sound for invalid operation
Protection	Beep sound for alarm occurrence
SCPI	Beep sound for SCPI errors

- 3 Use the rotary knob to select Enable or Disable, and then press ENTER.**  
This completes the setting.



## Setting the DIGITAL2 signal input/output

### 1 Press SYSTEM.

If the Configure screen does not appear, press Configure.

### 2 Use the rotary knob to select Direction under Digital2, and then press Edit.

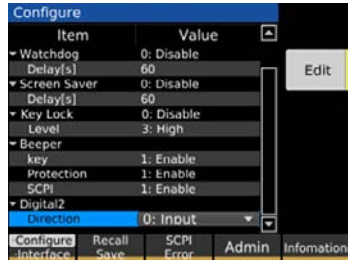

### 3 Use the rotary knob to select Input (digital input) or Output (digital output), and then press ENTER.

This completes the setting.

# Displaying/Changing the Interface Settings

You can set the following parameters.

Items that have the ✓ mark in the “Reset” column are returned to their factory default values when the interface settings are reset.

Parameter	Value <sup>1</sup>	Description	Reset
IP Address	—	IP address	
Method	<u>Automatic</u> (auto)/Static (fixed)	IP address assignment method	✓
IP Address	—	IP address	—
Subnet Mask	—	Subnet mask	—
Default Gateway	—	Default gateway	—
DNS Server	—	DNS server address	
DNS Server 1	—	Primary DNS server address	—
DNS Server 2	—	Secondary DNS server address	—
WINS Server	—	WINS server address	
WINS Server 1	—	Primary WINS server address	—
WINS Server 2	—	Secondary WINS server address	—
Host name & Services	—	Host name and service	
Desired Hostname	Enter the host name (up to 15 characters). Factory default is model name and serial number.	Host name setting	—
Desired Description	Enter the service name (up to 63 characters). Factory default is KIKUSUI XXXX Electronic Load (XXXX = model name) and serial number.	mDNS service name setting	—
Dynamic DNS	<u>Enable/Disable</u>	Setting of dynamic DNS	✓
mDNS	<u>Enable/Disable</u>	Setting of multicast DNS	✓
NetBIOS Over TCP/IP	<u>Enable/Disable</u>	NetBIOS Over TCP/IP setting	✓
Auto Clock Adjustment	—	Auto clock	
NTP Server Hostname	ntp.nict.jp	NTP server address	—
Auto Adjustment	<u>Enable/Disable</u>	Setting of auto clock adjustment	—
RS232C Settings	—	RS232C settings	
Baudrate	9600/ <u>19200</u> / 38400/ 57600/ 115200	Baud rate [bps]	—
Data Bits	<u>8</u> (fixed)	Data length	—
Stop Bits	1 (fixed)	Stop bits	—
Flow Control	<u>None</u> / CTS-RTS	Flow control	—

1. Factory default settings are underlined.

## 1 Press SYSTEM and then Interface.

The Interface screen (View Mode) appears.

If the Interface screen does not appear, press Interface again.

View Mode is for checking the settings. You cannot change the settings.

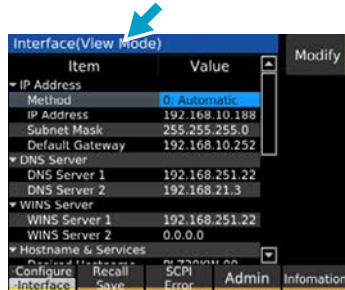

## 2 Press Modify, and use the rotary knob to select a setting.

The screen switches to Modify Mode. Modify Mode is for changing the settings.

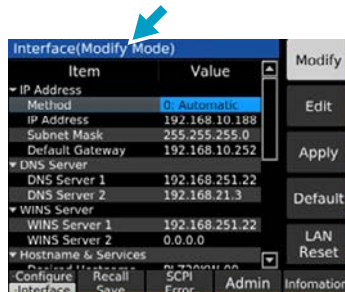

## 3 Press Edit, use the numeric keypad or the rotary knob to enter the value, and then press ENTER.

## 4 Press Apply and then ENTER.

This completes the setting. The screen switches to View Mode.

## Resetting the interface settings

---

Interface settings that have a ✓ mark in the reset column in (p.122) above are returned to the factory default setting.

- 1 Press SYSTEM and then Interface.**  
If the Interface screen does not appear, press Interface again.
- 2 Press Modify and then LAN Reset.**  
A confirmation screen appears.
- 3 Press ENTER.**  
The interface setting is reset.

## Returning the interface settings to the factory default values

---

- 1 Press SYSTEM and then Interface.**  
If the Interface screen does not appear, press Interface again.
- 2 Press Modify and then Default.**  
A confirmation screen appears.
- 3 Press ENTER.**  
The interface settings are returned to the factory default values.

# Displaying SCPI Errors

---

You can check the content of the SCPI error when an SCPI error occurs during remote control.

Up to 16 errors are displayed. If the 17th error occurs, the 16th error changes to “-350 Queue overflow,” and subsequent errors are not displayed.

## 1 Press **SYSTEM** and then **SCPI Error**.

The SCPI error is displayed. For details on errors, see the Communication Interface Manual on the included CD-ROM.

Pressing Clear or restarting the product will clear the error.

# Setting the Date/Time

The date and time are used when saving setup memory.

If you change the time zone, the year, month, and day change accordingly.

If the product is connected to LAN and can access the Internet, the year, month, and day will be updated automatically when you set the time zone.

## 1 Press SYSTEM, Admin, and then Date Time.

## 2 Set the time zone and the date and time.

Each time you press Tab, the item that you can set changes.

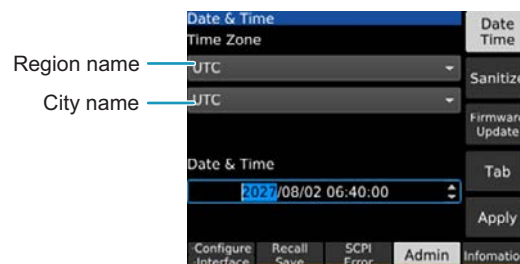

Purpose	Operation
Set the time zone (region name)	Press Tab to select the item in the top row of Time Zone, and then use the rotary knob to select the region name.
Set the time zone (city name)	Press Tab to select the item in the bottom row of Time Zone, and then use the rotary knob to select the city name.
Set the year, month, day, and time.	Press Tab to select the year, month, day, or time of Date & Time, and use the numeric keypad or rotary knob to enter the value.

## 3 Press Apply.

This completes the setting.

# Factory Default Settings and Reset Settings

The product provides “factory default settings” and “reset settings” as default settings.

## Restoring the factory default settings

Restoring the factory default settings deletes all the user data\*.

For details about the factory default setting, see “Main settings at factory default and at reset” (p. 129).

\*: The user data is deleted in accordance with the NISPOM (National Industrial Security Program Operating Manual) standard.

You can also return only the interface settings to their factory default values (p. 124).

### 1 Press SYSTEM, Admin, and then Sanitize.



### 2 Press Execute.

A confirmation screen appears.

### 3 Use the rotary knob to select OK, and then press ENTER.

The product restarts, and the factory default settings are restored.

**NOTE** The error “-314 Save/recall memory lost” always occurs when the product restarts, but this is actually not an error.

## Restoring the reset settings

You can reset some of the settings to their factory defaults at power-on.

For the items that are reset, see “Main settings at factory default and at reset” (p.129).

You can also reset only the interface settings (p.124).

### Resetting at power-on

**1 Press SYSTEM.**

If the Configure screen does not appear, press Configure.

**2 Use the rotary knob to select Power on, and then press Edit.**

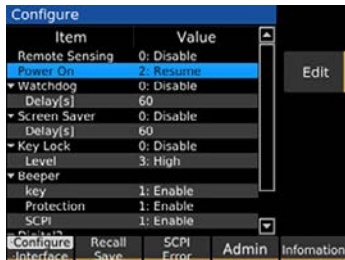

**3 Use the rotary knob to select RST, and then press ENTER.**

**4 Turn the POWER switch off and then back on.**

The product restarts with some of the settings reset to their factory defaults.

### Resetting immediately

**1 Press SYSTEM > SCPI.**

**2 Press \*RST.**

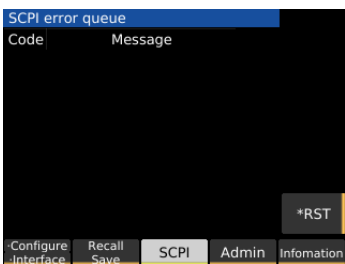

A confirmation screen appears.

**3 Press ENTER.**

Some of the settings are reset.



## Main settings at factory default and at reset

The main settings at factory default and at reset, for each of the settings that can be done with the SOURCE key, MEASURE key, SEQUENCE key, and SYSTEM key, are listed below. All items that have the ✓ mark in the “Reset” column are returned to their factory default values upon reset.

### SOURCE function settings

Item	Factory default		Reset	
	PLZ12005WH	PLZ20005WH		
Operation mode	CC		✓	
CC range (CR range)	H range		✓	
Current	0 A		✓	
Conductance	0 S		✓	
Voltage	0 V		✓	
Power	0 W		✓	
ABC preset value	CC mode	0 A	✓	
	CR mode	0 S	✓	
	CV mode	0 V	✓	
	CP mode	0 W	✓	
Response speed in CR mode	Normal		✓	
Response speed in CV mode	Normal		✓	
Response speed for ARB mode	500 μs		✓	
Soft start time	500 μs		✓	
Cutoff function	Elapsed time	Disable	✓	
	Voltage drop	Disable	✓	
	Integrated current	Disable	✓	
	Integrated power	Disable	✓	
External control	CC/CR/CP mode	Disable	✓	
	CV mode	Disable	✓	
	CC Add	Disable	✓	
	Input Logic	Positive	✓	
Pulse	Function	Disable	✓	
	Current (Depth)	0 A	✓	
	Conductance (Depth)	0 S	✓	
	Duty cycle	50 %	✓	
	Frequency	1 Hz	✓	
Sine	Function	Disable	✓	
	Amplitude	0 A	✓	
	Frequency	1 Hz	✓	
Slew rate	0.01 A/μs	0.02 A/μs	✓	
Protection functions	Overcurrent protection setting	264 A	440 A	✓
	Operation at overcurrent protection activation	Limit		✓
	Overpower protection setting	13.2 kW	22 kW	✓
	Operation at overpower protection activation	Limit		✓
	Undervoltage protection setting	OFF		✓
	Operation at undervoltage protection activation	Limit		✓
Number of data points of I-V characteristics map	3 (all 0 A)		✓	

## MEASURE function settings

Item		Factory default	Reset
Measurement function	Number of measurement values to be recorded	1	✓
	Delay	0 s	✓
	Measurement interval function (Interval)	Disable	✓
	Measurement interval time (Interval Time)	0.1 s	✓
	Trigger source	Immediate	✓
	Measurement time (Sense Aperture)	0.1 s	✓
Integrated data recording function	Integrated data recording period (Integral Gate)	Load On	✓
	Resetting of integrated data before start of recording (Reset)	Auto	✓
Integrated data display	Elapsed time	Enable	✓
	Integrated current	Disable	✓
	Integrated power	Disable	✓

## SEQUENCE function settings

Item		Factory default	Reset
Program		No program	—
Trigger source		Immediate	—
Trigger delay		0 s	—

## SYSTEM function settings

Item		Factory default	Reset
Remote sensing		Disable	—
Panel settings at startup (Power On)		Resume	—
Watchdog protection function		Disable	—
Set time for watchdog protection function (Delay)		60 s	—
Screen saver		Disable	—
Screen saver startup time (Delay)		60 s	—
Key lock level		High	—
Beep sound	In case of invalid operation (Key)	Enable	—
	In case of alarm activation	Enable	—
	In case of SCPI error	Enable	—
I/O direction of DIGITAL2 signal		Input	—
Time zone		UTC <sup>1</sup>	—

1. If reset to the factory default value, set the date and time ([p.126](#)).

For details on the factory default settings and reset settings for the interface, see “Displaying/Changing the Interface Settings” ([p.122](#)).

# Updating

You can update the product's firmware by using a USB memory device.

If there is an update, you can obtain it from the download service on the Kikusui website (<http://www.kikusui.co.jp/en/download/>).

**NOTE** Save the update files (Update.img, CHECKSUM.md5) in the root directory of the USB memory device. Do not change the names of the update files.

## 1 Press SYSTEM, Admin, and then Firmware Update.

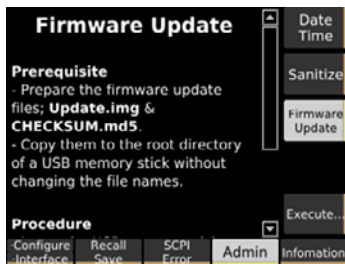

## 2 Insert the USB memory device on which the update files have been saved into the USB port on the front panel, and then press Execute.

An update screen appears.

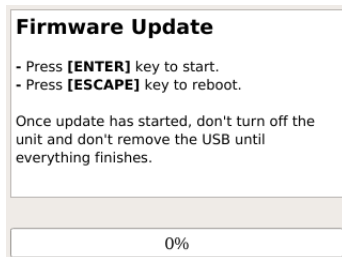

## 3 Press ENTER.

Do not turn off the POWER switch while updating is in progress. Do not remove the USB memory device.

## 4 After the update complete screen is displayed, turn the POWER switch off and then back on.

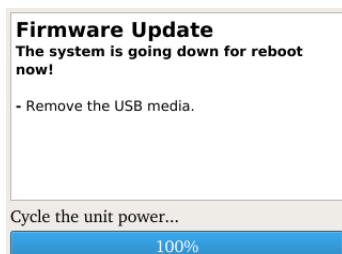

Updating is complete.

# Displaying the Device Information

You can display the model name, serial number, firmware version, IP address, and other device information.

## 1 Press SYSTEM and then Information.

The device information is displayed. You can scroll the screen by turning the rotary knob.

If a connection is established when IP Address > Method is set to Automatic in the interface settings (p.122) (the LAN connection status icon in the upper right of the display is green), the automatically assigned IP address is displayed next to IP Address.



# Maintenance

---

## Inspection

---

To purchase accessories or options, contact your Kikusui agent or distributor.

## Overhaul

---

The electrolytic capacitors and fan motor inside the product are consumable parts.

We recommend that you have the product overhauled every 10000 operating hours or so (the frequency depends on the usage conditions), along with internal inspection and cleaning. To have your unit overhauled, contact your Kikusui agent or distributor.

## Backup battery replacement

---

The product has a battery inside. The battery's service life differs depending on the environment that the product is used in, but three years after it is purchased is a rough estimate for the battery's service life. When the battery is exhausted, the time becomes inaccurate. For information about replacing the battery, contact your Kikusui agent or distributor.

## Calibration

---

The product is calibrated before shipment. To maintain long-term performance, we recommend periodic calibration. To have your product calibrated, contact your Kikusui agent or distributor.

# Specifications

Unless specified otherwise, the specifications are for the following settings and conditions.

- The product is warmed up for at least 30 minutes.
- TYP: These are typical values that are representative of situations where the product operates in an environment with an ambient temperature of 23 °C. These values do not guarantee the performance of the PLZ12005WH/PLZ20005WH.
- setting: Indicates a setting.
- range: Indicates the rated value of each range.
- reading: Indicates a readout value.
- rating: Indicates a rated value.
- Open: Indicates equivalence to the state in which the load input terminals are opened.
- Using DC INPUT

## Ratings

Item	PLZ12005WH	PLZ20005WH
Operating voltage (DC)	10 V to 800 V	
Current	240 A	400 A
Power	12000 W	20000 W
Load input terminal's isolation voltage	±800 V	
Minimum operating voltage <sup>1</sup>	At the rated current	10 V
	When the current begins to flow	1.5 V or less

1. The minimum operating voltage is 1.5 V when the current begins to flow and 10 V at the rated current. At the load input terminals.

## Constant current (CC) mode

Item	PLZ12005WH	PLZ20005WH
Operating range	0 A to 240 A	0 A to 400 A
Setting range	0 A to 242.400 A	0 A to 404.00 A
Resolution	5 mA	10 mA
Setting accuracy	±(0.2 % of setting + 0.1 % of rating)	
	Parallel Operation	±(0.4 % of setting + 0.2 % of rating)

## Constant resistance (CR) mode

Item		PLZ12005WH	PLZ20005WH	
Operating range <sup>1</sup>	H range	6000 mS to 0 S	10 S to 0 S	
	L range	60 mS to 0 S	100 mS to 0 S	
Setting range	H range	6060.0 mS to 0 S	10.1000 S to 0 S	
	L range	60.600 mS to 0 S	101.000 mS to 0 S	
Resolution	H range	0.2 mS		
	L range	0.002 mS		
Setting accuracy <sup>2</sup>	H range	$\pm(0.5 \% \text{ of setting} + 0.5 \% \text{ of rating}^3)$		
	L range	$\pm(0.5 \% \text{ of setting} + 0.2 \% \text{ of rating}^3)$		
	Parallel Operation	H range	$\pm(1.0 \% \text{ of setting} + 1.0 \% \text{ of rating}^3)$	
		L range	$\pm(1.0 \% \text{ of setting} + 0.4 \% \text{ of rating}^3)$	
Response speed		NORM/FAST		

1. Conductance [S] = input current [A]/input voltage [V] = 1/resistance [ $\Omega$ ]
2. Converted value at the input current. At the sensing terminals during remote sensing.
3. Rated current

## Constant voltage (CV) mode

Item		PLZ12005WH	PLZ20005WH
Operating range		10 V to 800 V	
Setting range		0 V to 808.00 V	
Resolution		20 mV	
Setting accuracy <sup>1</sup>		$\pm(0.05 \% \text{ of setting} + 0.05 \% \text{ of rating})$	
	Parallel Operation	$\pm(0.1 \% \text{ of setting} + 0.1 \% \text{ of rating})$	
Response speed		NORM/FAST	

1. With the input voltage within the operating range, and at the sensing terminals during remote sensing.

## Constant power (CP) mode

Item		PLZ12005WH	PLZ20005WH
Operating range		0 W to 12000 W	0 W to 20000 W
Setting range		0 W to 12120 W	0 W to 20200 W
Resolution		0.5 W	
Setting accuracy		$\pm(0.5 \% \text{ of rating}^1 + 0.2 \text{ A} \times \text{Vin}^2)$	$\pm(0.5 \% \text{ of rating}^1 + 0.4 \text{ A} \times \text{Vin}^2)$
	Parallel Operation	$\pm(1 \% \text{ of power rating} + 0.1 \% \text{ current rating} \times \text{Vin}^2)$	

1. Rated power
2. Load input terminal voltage or SENSING terminal voltage.

## Arbitrary I-V characteristics (ARB) mode

Item	PLZ12005WH	PLZ20005WH
Operating range	Three to 100 points of current values can be specified for the input voltage. Linear interpolation is applied between specified points.	
Response speed	500 $\mu$ s, 1 ms, 2 ms, 5 ms, 10 ms, 20 ms, 50 ms, 100 ms, or off	

## Measurement function

### Voltmeter

Item	PLZ12005WH	PLZ20005WH
Display	0.00 V to 800.00 V	
Resolution	10 mV	
Accuracy	$\pm(0.05\%$ of reading + 0.05 % of rating)	
	Parallel operation (TYP)	$\pm(0.1\%$ of reading + 0.1 % of rating)

### Ammeter

Item	PLZ12005WH	PLZ20005WH
Display	0.00 A to 240.00 A	0.00 A to 400.00 A
Resolution	10 mA	
Accuracy	$\pm(0.2\%$ of reading + 0.1 % of rating)	
	Parallel operation (TYP)	$\pm(0.4\%$ of reading + 0.2 % of rating)

### Power display

Item	PLZ12005WH	PLZ20005WH
Display	Displays the product of the voltmeter reading and ammeter reading	

### Measurement trigger

Item	PLZ12005WH	PLZ20005WH
Trigger Source	Immediate, BUS, DIGITAL2, MSync, TALink, LoadOff	
Trigger Count	1 to 65536	
Trigger Delay	0 $\mu$ s to 100 s	
Interval	Disable/Enable	
Interval Time	10 $\mu$ s to 3600 s	
Sense Aperture	10 $\mu$ s to 1 s	



## Pulse function

Item	PLZ12005WH		PLZ20005WH
Operation mode	CC and CR		
Frequency setting range	1.0 Hz to 10.0 kHz		
Frequency setting resolution <sup>1</sup>	1 Hz to 10 Hz	0.1 Hz	
	11 Hz to 100 Hz	1 Hz	
	110 Hz to 1000 Hz	10 Hz	
	1.1 kHz to 10.0 kHz	0.1 kHz	
Frequency setting accuracy	1 Hz to 5.0 kHz	±(0.5 % of setting)	
	5.1 Hz to 10.0 kHz	±(1.0 % of setting)	
Duty cycle setting range, step	1 Hz to 10 Hz	5.0 % to 95.0 %, 0.1 % steps	
	11 Hz to 100 Hz		
	110 Hz to 1000 Hz		
	1.1 kHz to 10.0 kHz	5 % to 95 % <sup>2</sup> , 1 % steps	
Switch value (Depth) <sup>3</sup>	CC mode	0 A to 242.40 A	0 A to 404.00 A
	CR mode H range	6.0600 S to 0 S	10.1000 S to 0 S
	CR mode L range	60.600 mS to 0 S	101.000 mS to 0 S

- (Reference) The resolution actually set in the device is period resolution  $\Delta T = 1 \mu\text{s}$ , as shown in the equation below. For example, if you specify 9300 Hz, the period set in the device will be  $n \times \Delta T = 108 \times 1 \mu\text{s} = 108 \mu\text{s}$  (where n is a number set in the device). Converted to frequency, this becomes  $1/108 \mu\text{s} = 9259 \text{ Hz}$ .
- The minimum time span is 20  $\mu\text{s}$ . The minimum duty cycle is limited by the minimum time span.
- The switch value is limited to the set current or set conductance or less.

## Sine function

Item	PLZ12005WH		PLZ20005WH
Operation mode	CC		
Frequency setting range	1.0 Hz to 1 kHz, 2 kHz, 5 kHz, 10 kHz		
Frequency setting resolution <sup>1</sup>	1 Hz to 10 Hz	1 Hz	
	20 Hz to 100 Hz	10 Hz	
	200 Hz to 1000 Hz	100 Hz	
Frequency setting accuracy	300 Hz to 900 Hz	±(1.0 % of setting)	
	Other than above frequency	±(0.5 % of setting)	

- (Reference) The resolution actually set in the device is period resolution  $\Delta T = 20 \mu\text{s}$ , as shown in the equation below. For example, if you specify 900 Hz, the period set in the device will be  $n \times \Delta T = 56 \times 20 \mu\text{s} = 1120 \mu\text{s}$  (where n is a number set in the device). Converted to frequency, this becomes  $1/1120 \mu\text{s} \approx 893 \text{ Hz}$ .

## Slew rate

Item	PLZ12005WH	PLZ20005WH
Operation mode	CC	
Operation range	0.01 A/ $\mu$ s to 12 A/ $\mu$ s	0.02 A/ $\mu$ s to 20 A/ $\mu$ s
Resolution	0.2 mA/ $\mu$ s	0.5 mA/ $\mu$ s
Setting accuracy <sup>1</sup>	$\pm$ (10 % of setting +20 $\mu$ s)	

1. Time to change from 10 % to 90 % when the current is changed from 0 % to 100 % of the rated current

## Soft start

Item	PLZ12005WH	PLZ20005WH
Operation mode	CC	
Time setting range	500 $\mu$ s, 1 ms, 2 ms, 5 ms, 10 ms, 20 ms, 50 ms, 100 ms, or off	

## Alarm function

### Alarm 1

Item	PLZ12005WH	PLZ20005WH
Overvoltage detection	Turns off the load when a voltage that is 110 % of the rating or higher is applied.	
Reverse-connection detection	Turns off the load when approximately -1 % of the rated current flows through the load input terminals.	
Overheat detection	Turns off the load when the heatsink temperature reaches 100°C	
Alarm input detection	Turns off the load when a voltage between 0 V and 1.5 V is applied to ALARM INPUT (pin 6) of the EXT CONT connector.	
Parallel operation anomaly detection	Turns off the load when any of the following errors occurs. <ul style="list-style-type: none"> <li>• An error occurred in the communication between the master unit and slave unit during parallel operation.</li> <li>• A slave unit's power supply was interrupted.</li> <li>• An overheating was detected on the master or slave unit.</li> <li>• An overcurrent flowed through the front-panel DC INPUT terminals.</li> <li>• A PLZ-5W series was connected to a slave unit.</li> </ul>	

### Alarm 2

Item		PLZ12005WH	PLZ20005WH
Overcurrent protection (OCP)	Setting range	0.00 A to 264.00 A	0.0 A to 440.0 A
	Resolution	10 mA	100 mA
	Protection operation	Either load off or limitation can be selected	
Overpower protection (OPP)	Setting range	0 W to 13200 W	0 W to 22000 W
	Resolution	1 W	
	Protection operation	Either load off or limitation can be selected	
Undervoltage protection (UVP)	Setting range	0.00 V to 800.00 V, or off	
	Resolution	20 mV	
	Protection operation	Either load off or limitation can be selected	
Watchdog protection (WDP)	Setting range	1 s to 3600 s or off	
	Protection operation	Load off	

## Sequence function

Item	PLZ12005WH	PLZ20005WH
Operation mode	CC, CR, CV, CP	
Maximum number of programs	30	
Maximum number of steps	10000	
Step execution time	50 μs to 3600000 s (50 μs to 1000 h)	
Time resolution	1 μs	

## Other functions

Item		PLZ12005WH	PLZ20005WH	
Remote sensing	Input voltage rating <sup>1</sup>	800 V <sup>2</sup>		
	Isolation voltage	±800 V		
Number of units in parallel operation <sup>3</sup>		5 units		
Mutual synchronized operation		Load on/off		
		Synchronization of sequence execution, and sequence resumption		
		Recording timing of measured values		
Elapsed time display		Displays the time from load on to load off.		
	Range	0 s to 3600000 s (1000 h 0 min 0 s)		
Ampere-hour meter display		Displays integrated current		
	Range	0.000 Ah to 800000 Ah	0 Ah to 1400000 Ah	
Watt-hour meter display		Displays integrated power		
	Range	0 Wh to 400000000 Wh	0 Wh to 650000000 Wh	
Cutoff <sup>4</sup>	Elapsed time	The load turns off when the elapsed time value reaches the specified value.		
		Setting range	0 s to 3600000 s (1000 h 0 min 0 s)	
		Resolution	1 s	
	Voltage drop	The load turns off when the voltmeter value reaches the specified value.		
		Setting range	0.00 V to 800.00 V	
		Resolution	0.02 V	
	Integrated current	The load turns off when the ampere-hour meter value reaches the specified value.		
		Setting range	0 Ah to 800000 Ah	0 Ah to 1400000 Ah
		Resolution	0.001 mAh (0.000 mAh to 1 000.000 mAh) 0.001 Ah (1.001 Ah to 1 000.000 Ah) 0.001 kAh (1.001 kAh to 1 000.000 kAh) 0.001 MAh (1.001 MAh to 1.400 MAh)	
	Integrated power	The load turns off when the watt-hour meter value reaches the specified value.		
		Setting range	0 Wh to 400000000 Wh	0 Wh to 650000000 Wh
		Resolution	0.001 Wh (0.000 Wh to 1 000.000 Wh) 0.001 kWh (1.001 kWh to 1 000.000 kWh) 0.001 MWh (1.001 MWh to 650.000 MWh)	

1. There are limitations depending on the actual power that the load consumes.
2. A value obtained by adding the voltage between the load input terminals to the total potential difference between the positive and negative load input terminal and the SENSING terminals
3. The parallel operation terminal operates at the electric potential of the negative load terminal.
4. Multiple cutoff causes selectable

## Common specifications

### EXT CONT connector

Item	Specifications
Load on/off control input	Logic level switchable. Pulled up to 5 V by a 10 k $\Omega$ resistor. The thresholds are HIGH: 3.5 V to 5 V, LOW: 0 V to 1.5 V.
Alarm input	An alarm is activated with a voltage between 0 V and 1.5 V. Pulled up to 5 V by a 10 k $\Omega$ resistor. The thresholds are HIGH: 3.5 V to 5 V, LOW: 0 V to 1.5 V.
Alarm clearing input	After an alarm occurs, eliminate the root cause of the alarm, and change the input to pin 5 of the EXT CONT connector from a low level signal to a high level signal. The alarm will be cleared on the rising edge of this signal. Pulled up to 5 V by a 10 k $\Omega$ resistor. The thresholds are HIGH: 3.5 V to 5.0 V, LOW: 0 V to 1.5 V.
Trigger input	Paused sequence operation resumes when a voltage between 0 V and 0.66 V is received. Pulled up to 5 V by a 10 k $\Omega$ resistor. The thresholds are HIGH: 2.31 V to 3.3 V, LOW: 0 V to 0.66 V.
External voltage control input (CC, CR, CP mode)	Controls the load settings of CC, CR, CP mode through external voltage input. The input impedance is approx. 10 k $\Omega$ . CC: The setting can be controlled in the range of 0 % to 100 % of the rated current through external voltage input of 0 V to 10 V. CR: The setting can be controlled in the range of 0 % to 100 % of the conductance setting through external voltage input of 0 V to 10 V. CP: The setting can be controlled in the range of 0 % to 100 % of the rated power through external voltage input of 0 V to 10 V.
Setting accuracy	$\pm$ (1 % of range) (TYP value in CC mode)
External voltage control input (CV mode)	The load setting of CV mode can be controlled through external voltage input. The rated voltage can be controlled in the range of 0 % to 100 % with 0 V to 10 V. Input impedance: approx. 10 k $\Omega$ .
Setting accuracy	$\pm$ (1 % of range) (TYP)
External voltage control input (superimposing in CC mode)	Controls the load setting of CC mode by adding current through external voltage input. Adds current in the range of -100 % to 100 % of the rated current for -10 V to 10 V. Input impedance: approx. 10 k $\Omega$ .
Setting accuracy	$\pm$ (1 % of range) (TYP)
Load-on status output	On when load is on. Open-collector output from a photocoupler. <sup>1</sup>
ALARM 1 output	ON when overvoltage detection, reverse-connection detection, overheat detection, alarm input detection, or parallel operation anomaly detection is activated. Open-collector output from a photocoupler. <sup>1</sup>
ALARM 2 output	Turns on when OCP, OPP, UVP, or WDP is activated. Open-collector output from a photocoupler. <sup>1</sup>
DIGITAL 0 output	Logic signal output during a step of a sequence. Output impedance: approx. 330 $\Omega$ . The thresholds are HIGH: 2.5 V to 3.3 V, LOW: 0 V to 0.4 V.
DIGITAL 1 output	
DIGITAL 2 input/output	Input/output switchable. Output: Logic signal output during a step of a sequence. Output impedance: 330 $\Omega$ . The thresholds are HIGH: 2.5 V to 3.3 V, LOW: 0 V to 0.4 V. Input: Trigger input signal for the sequence and the measurement functions. The thresholds are HIGH: 2.31 V to 3.3 V, LOW: 0 V to 0.66 V.
Current monitor output	Outputs 0 V to 10 V for 0 % to 100 % of the rated current. Output impedance: 1 k $\Omega$ (TYP)
Accuracy	$\pm$ (1 % of range) (TYP)
All pins	800 V reinforced insulation between each pin and load terminals

1. The maximum voltage that can be applied to the photocoupler is 30 V. The maximum current is 4 mA.

## BNC connector

Item		Specifications
Trigger output		Transmits 10 $\mu$ s pulses during step execution when trigger output is set in a sequence. Transmits 10 $\mu$ s pulses during pulse operation. Output impedance 200 $\Omega$ , output voltage HIGH: 4.2 V to 5 V, LOW: 0 V to 0.4 V.
Current monitor output	Output voltage	0 V to 10 V for 0 % to 100 % of the rated current
	Output impedance	50 $\Omega$ (TYP)
	Accuracy	$\pm$ (1 % of range)
Voltage monitor output	Output voltage	1/100 of the measured voltage from 0 V to 8 V
	Output impedance	50 $\Omega$ (TYP)
	Accuracy	$\pm$ (1 % of range)
Isolation voltage		$\pm$ 30 V

## Communication function

Item		Specifications
RS232C	Hardware	D-SUB 9-pin connector. Baud rate: 9600, 19200, 38400, 115200 bps. Data length: 8 bits, Stop bits: 1 bit, Parity bit: None Flow control: No, CTS-RTS
	Message terminator	LF during reception, LF during transmission.
USB (device)	Hardware	Standard type B socket. Complies with the USB 2.0 specification. Data rate: 480 Mbps (High Speed).
	Message terminator	LF or EOM during reception, LF + EOM during transmission.
	Device class	Complies with the USBTMC-USB488 device class specifications.
USB (host)	Hardware	Standard type A socket Complies with the USB 2.0 specifications. Data rate: 480 Mbps (High Speed).
LAN	Hardware	IEEE 802,3 100Base-TX/10Base-T Ethernet IPv4, RJ-45 connector.
	Compliant standards	LXI 1.4 Core Specification 2011
	Communication protocol	VXI-11, HiSLIP, SCPI-RAW, SCPI-Telnet
	Message terminator	VXI-11, HiSLIP: LF or END during reception, LF + END during transmission. SCPI-RAW: LF during reception, LF during transmission.

## General specifications

Item	PLZ12005WH	PLZ20005WH
Input voltage range	100 Vac to 240 Vac (90 Vac to 250 Vac) single phase	
Input frequency range	47 Hz to 63 Hz	
Power consumption	740 VAm <sub>ax</sub>	
Inrush current (peak value)	100 Vac	40 A <sub>max</sub>
	230 Vac	160 A <sub>max</sub>
Noise level	80 dB max. (standalone)	
Environmental conditions	Operating temperature range	0 °C to 40 °C
	Operating humidity range	20 %rh to 85 %rh (no condensation)
	Storage temperature range	-20 °C to 60 °C
	Storage humidity range	90 %rh or less (no condensation)
	Installation location	Indoor use, altitude of up to 2000 m, overvoltage category II
Insulation resistance	Primary ↔ chassis, input terminals, monitor terminals	1000 Vdc, 30 MΩ or more (70 %rh or less)
	Input terminals ↔ chassis, monitor terminals	
	Monitor terminals ↔ chassis	500 Vdc, 30 MΩ or more (70 %rh or less)
Withstanding voltage	Primary ↔ chassis, input terminals, monitor terminals	No abnormalities at 1500 Vac for 2 s.
	Input terminals ↔ chassis, monitor terminals	
	Monitor terminals ↔ chassis	No abnormalities at 350 Vac for 2 s
External dimensions	See (p.144).	See (p.145).
Weight	Approx. 64 kg	Approx. 93 kg
Accessories	See (p.3).	
Electromagnetic compatibility <sup>12</sup>	Complies with the requirements of the following directive and standards. EMC Directive 2014/30/EU EN 61326-1 (Class A <sup>3</sup> ) EN 55011 (Class A <sup>3</sup> , Group 1 <sup>4</sup> ) EN 61000-3-2 EN 61000-3-3 Applicable under the following conditions The maximum length of all cabling and wiring connected to the product must be less than 3 m.	
Safety <sup>1</sup>	Complies with the requirements of the following directive and standards. EMC Directive 2014/35/EU <sup>2</sup> EN 61010-1 (Class I <sup>5</sup> , Pollution Degree 2 <sup>6</sup> )	

1. Does not apply to specially ordered or modified products.
2. Only on models that have the CE marking on the panel.
3. This product conforms to Class A. This product is intended for use in an industrial environment. This product may cause interference if used in residential areas. Such use must be avoided unless the user takes special measures to reduce electromagnetic emissions to prevent interference to the reception of radio and television broadcasts.
4. This is a Group 1 instrument. This product does not generate and/or use intentionally radio-frequency energy, in the form of electromagnetic radiation, inductive and/or capacitive coupling, for the treatment of material or inspection/analysis purpose.
5. This product conforms to Class I. Be sure to ground the protective conductor terminal of this product. If not grounded properly, safety is not guaranteed.
6. Pollution is addition of foreign matter (solid, liquid or gaseous) that may produce a reduction of dielectric strength or surface resistivity. Pollution Degree 2 assumes that only non-conductive pollution will occur except for an occasional temporary conductivity caused by condensation.

## External dimensions

### PLZ12005WH

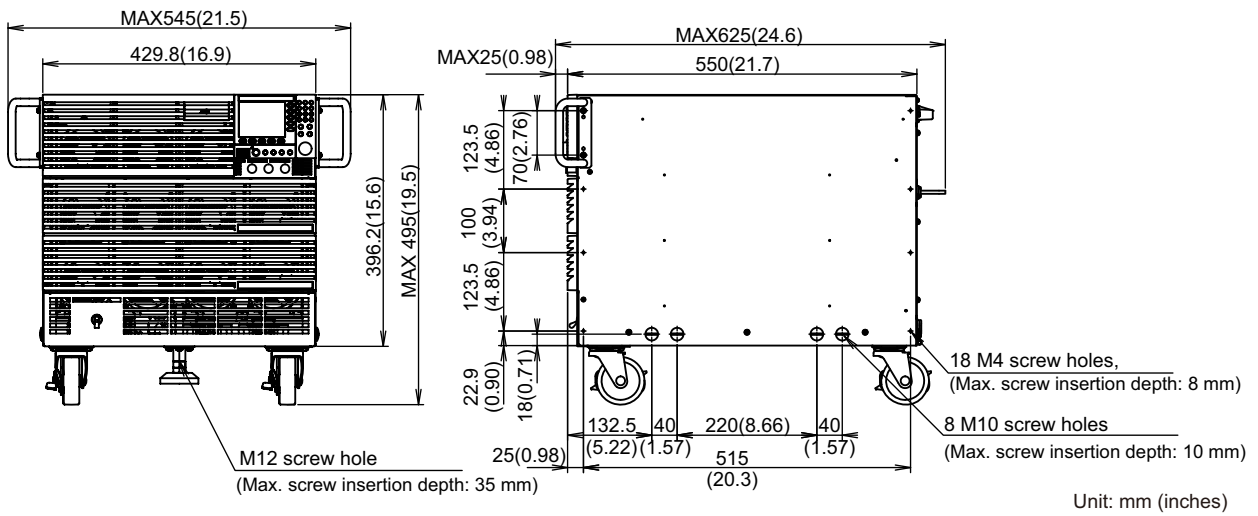
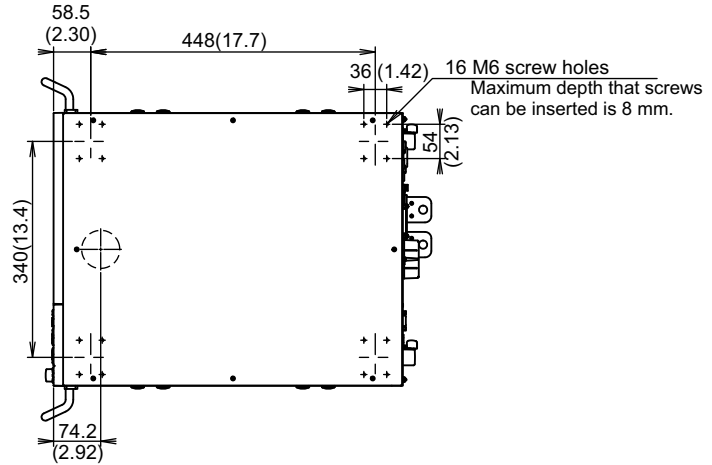



# External dimensions

## PLZ20005WH

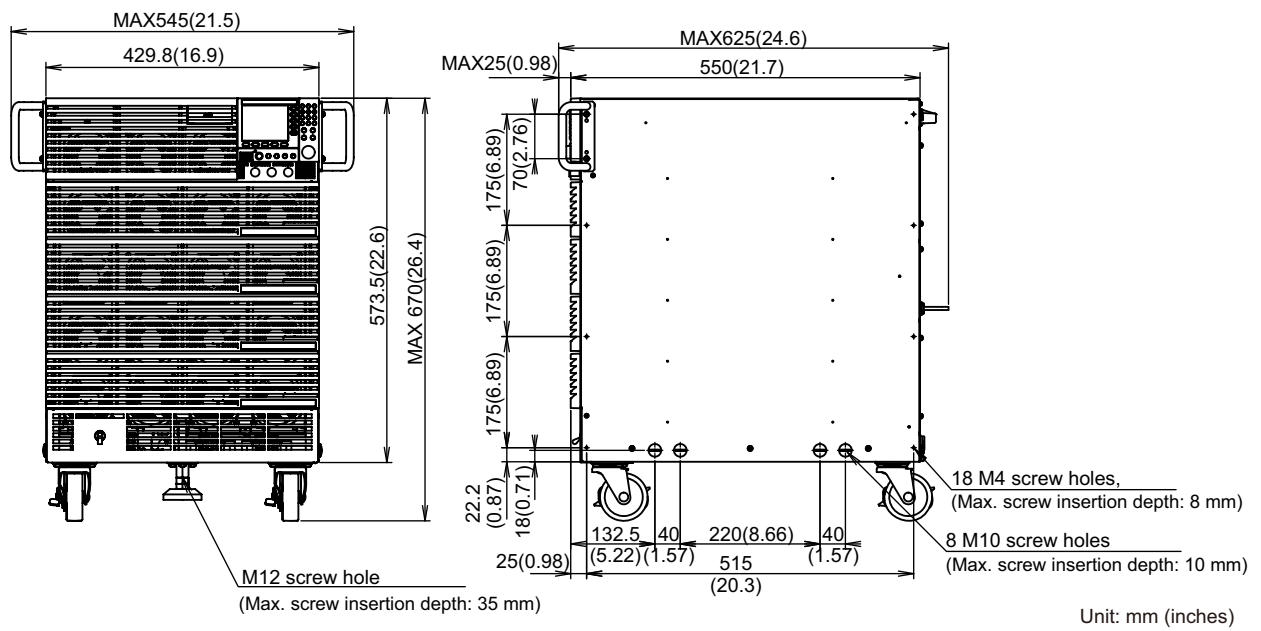
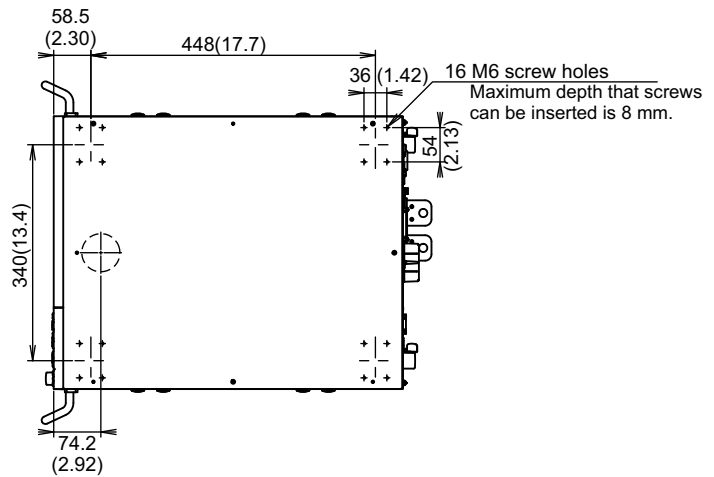

## Selecting the Load Cables

- ⚠ WARNING**
- **Risk of fire. Use load cables whose capacity is adequate for the product's rated input current.**
  - **Risk of electric shock. Use load cables with a voltage rating that meets or exceeds the isolation voltage ( $\pm 800$  V) of the product's load input terminals.**

- ⚠ CAUTION** Use load cables with a core diameter that is appropriate for the amount of current being used and with sturdy, flame-resistant insulation.

### ■ Current capacity of load cables

If the resistance of the cables used as the load cables is large, a large voltage drop may occur when current flows through the cables. This may result in the load input terminal voltage being lower than the minimum operating voltage of this product. Using the following table as a reference, select wiring whose nominal cross-sectional area is as thick as possible.

A wire's temperature is determined by the resistive loss based on the current, the ambient temperature, and the wire's external thermal resistance. The following table shows the current capacity of heat-resistant vinyl wires that have a maximum allowable temperature of 60 °C when one of the wires is separated and stretched out horizontally in air in an ambient temperature of 30 °C. The current must be reduced under certain conditions, such as when vinyl cables that have a low heat resistance are used, when the ambient temperature is 30 °C or greater, or when cables are bundled together and little heat is radiated.

Nominal cross-sectional area (mm <sup>2</sup> )	AWG	(reference cross-sectional area mm <sup>2</sup> )	Allowable Current <sup>1</sup> [A](Ta = 30 °C)	Kikusui- Recommended Current [A]
14	6	(13.3)	88	50
22	4	(21.15)	115	80
30	2	(33.62)	139	-
38	1	(42.41)	162	100
50	1/0	(53.49)	190	-
60	2/0	(67.43)	217	-
80	3/0	(85.01)	257	200
100	4/0	(107.2)	298	-
125	-	-	344	-
150	-	-	395	300
200	-	-	469	-
250	-	-	556	-
325	-	-	650	-

1. Excerpt from Japanese laws related to electrical equipment.

### ■ Taking measures against noise

When connecting cables that have the same heat resistance, separating the cables as much as possible to increase heat radiation enables a greater amount of current to flow. However, wiring the positive (+) and negative (-) output wires of the load cable side by side or bundling them together is more effective against unwanted noise. The Kikusui-recommended currents shown in the above table are allowable currents that have been reduced in consideration of the potential bundling of load cables. Use these values as a guideline when connecting load cables.

### ■ Limitations of the remote sensing

All wires have resistance. As the cable becomes longer or the current becomes larger, the voltage drop in the cable becomes greater. This results in a smaller voltage being applied at the load input terminal. Use cables with a large cross-sectional area to keep the load input terminal voltage from falling below the operating voltage.

# Methods to Stabilize Operation

Using the product at a fast response speed may cause instable oscillation or other operation instability. To achieve stabilization, the load cable inductance must be reduced and an appropriate response speed must be set.

## Reducing the load cable inductance

### Relationship between voltage induction when current is changed and inductance

Load cables have inductance  $L$ . If current  $I$  changes quickly, a large voltage is induced on both ends of the installed cables. If the impedance of the DUT is small, this voltage is entirely applied to the load input terminals of the electronic load. The load cable's inductance  $L$  and voltage  $E$  that is induced according to the changes in current  $I$  (hereafter referred to as the induced voltage) are expressed by the following expression:

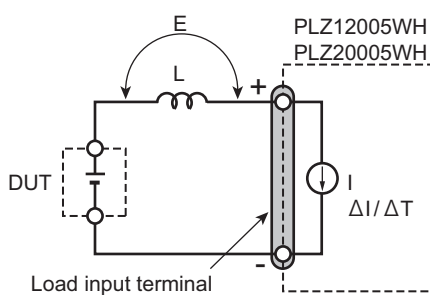

$$E = L \times (\Delta I / \Delta T)$$

- $E$  Induced voltage
- $L$  Wiring inductance
- $\Delta I$  Change in current
- $\Delta T$  Duration of time over which the current changes

Generally, a cable's inductance is  $1 \mu\text{H}$  per meter of cable. If 1 meter of cable (cumulative length of positive (+) polarity cable and negative (-) polarity cable) is used as the load cable between the DUT and electronic load, and the current change is  $50 \text{ A}/\mu\text{s}$ , the induced voltage is 50 V.

In constant voltage mode, constant resistance mode, and constant power mode, the load current is varied by the voltage at the load input terminals. This causes the operation to be easily affected by induced voltage.

### Preventing large voltage variation when load current changes suddenly

Use the shortest cables possible to connect the product and DUT, and twist the cables. If the cables are too thick to be twisted, bring the load input terminal's positive and negative terminal cables close together and make them parallel. If the load cable is long or has a large loop, the inductance of the wiring will be increased and large voltage variation will occur owing to current changes when the load current changes suddenly. Keep the voltage resulting from inductance equal to or higher than the minimum operating voltage and within the maximum input voltage range of the product.

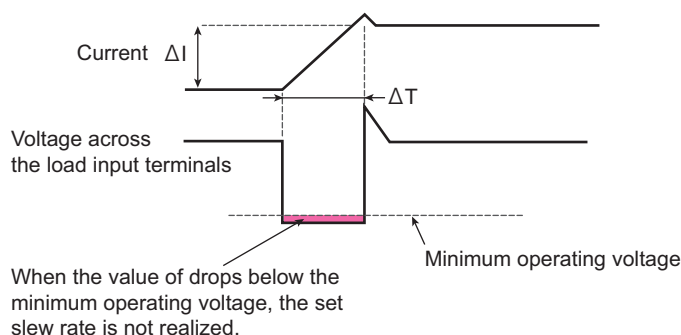

When the value of instantaneous voltage of the load input terminals drops below the minimum operating voltage, the set slew rate is not realized. You must be careful especially when the slew rate setting is high or when changing the load rapidly using large current.

In such a case, reduce the slew rate. If it is not necessary to operate at a high response speed, reduce the slew rate or reduce the response speed in CC mode or CR mode.

## Reducing oscillation caused by phase lag of the current

In CR mode, CV mode, and CP mode, phase lag of the current may cause control of the product to become unstable and oscillation phenomena to occur, even during DC operation. Therefore, use the shortest cables possible and twist them. If the cables are too thick to be twisted, bring the load input terminal's positive and negative terminal cables close together and make them parallel.

If only DC operation is required, a capacitor and a resistor may be connected to the load input terminal to reduce oscillation. Use the capacitor within its allowable ripple current.

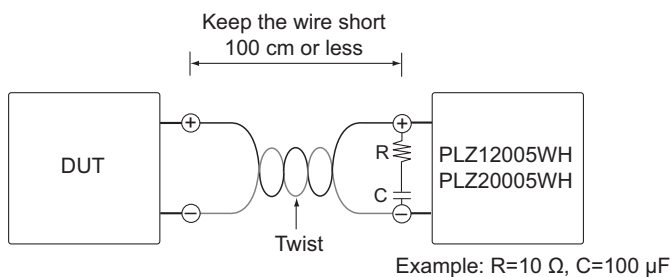

## Optimizing the response speed

The current phase is delayed with respect to the voltage due to the inductance of the wiring. Control of the product may become unstable and oscillation phenomena may occur.

If, in CV mode or CR mode, the response speed is set to Fast, stable operation can be secured by setting the response speed to Normal (p.57).

## Using remote sensing

Remote sensing (p.59) can be used to stabilize load current. In CP mode the response speed cannot be specified, but the operation can be stabilized by using remote sensing.

# Slew Rate for Small Currents

If the load current is made small in current (CC) mode, the specified slew rate may not be achieved. The following graph shows the current settings versus the actual current rise/fall times when the slew rate is set to 20 A/μs or 2 A/μs.

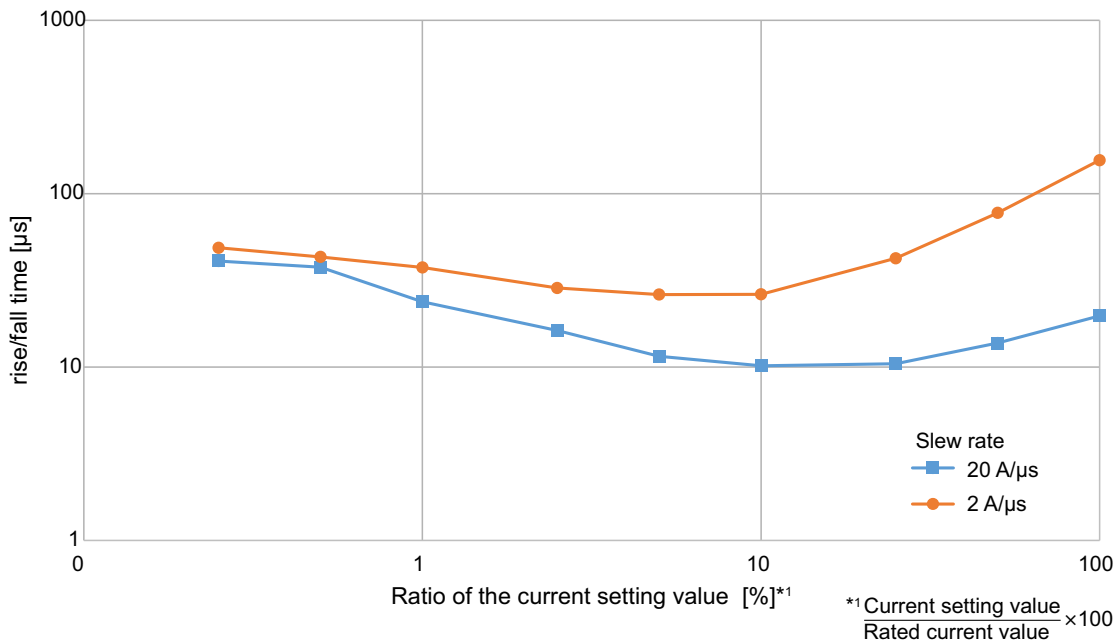

The following graphs show the relationship between the current setting value and change in current.

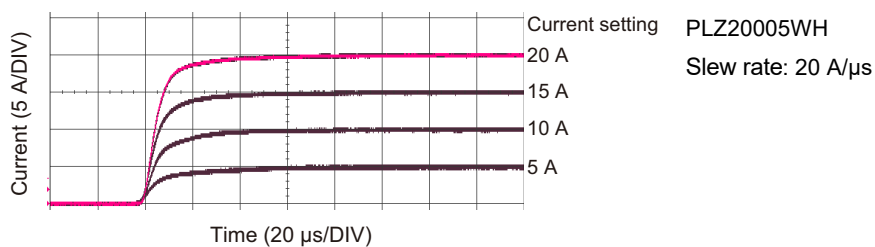
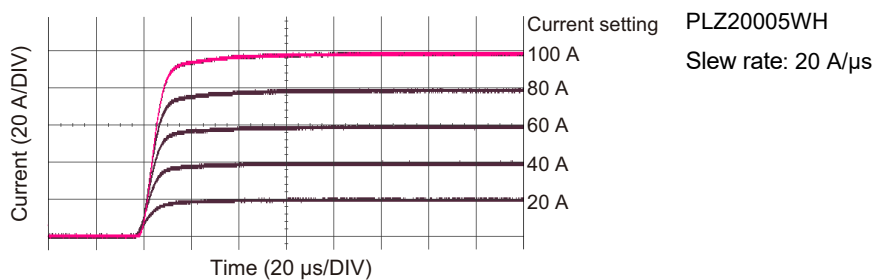
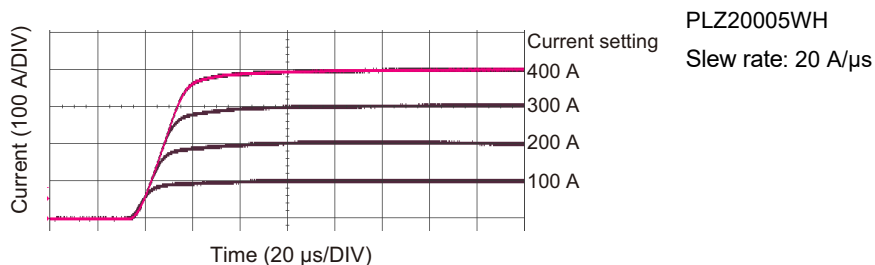

# Operating Area

As shown in the following figure (PLZ12005WH example), the product can be used within the area enclosed by the constant voltage line according to the rated voltage (L1), the constant power line according to the rated power (L2), the constant current line according to the rated current (L3), and the constant voltage line according to the minimum operating voltage (L4) (operating area where the specifications are guaranteed). The specifications are guaranteed at input voltages of 10 V and greater, but by reducing the current, operation is possible even with input voltages of less than 10 V (actual operating area). However, the specifications are not guaranteed in that case.

The voltage at which current starts flowing to the product is approximately 1.5 V. If the input voltage is gradually increased from 0 V, no current will flow until the voltage exceeds approximately 1.5 V. If the input voltage exceeds approximately 1.5 V and once a current greater than or equal to 1 % of the current rating starts flowing, the current can be kept flowing even when the input voltage is reduced.

For the operating range of each model, refer to “Operating area of each model” (p.158).

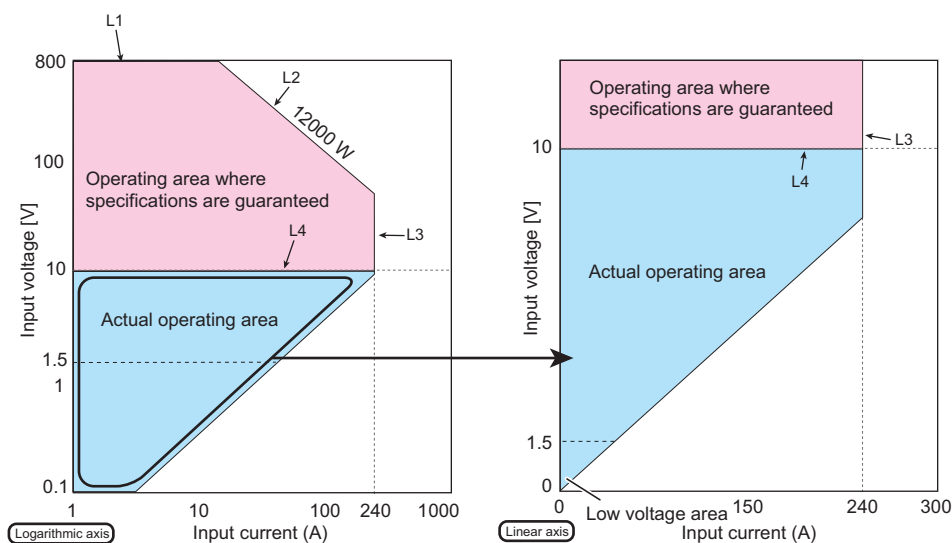

PLZ12005WH example

## Basic operation modes

The following five operation modes are available on the product.

- Constant current mode (CC mode)
- Constant resistance mode (CR mode)
- Constant power mode (CP mode)
- Constant voltage mode (CV mode)
- Arbitrary I-V characteristics mode (ARB mode)

## Operation of the constant current (CC) mode

### Operation of the constant current mode

When the product is used in CC mode, it operates as a constant current load as shown in the following figure. The product sinks specified current  $I$  even when output voltage  $V_1$  of the constant-voltage power supply changes.

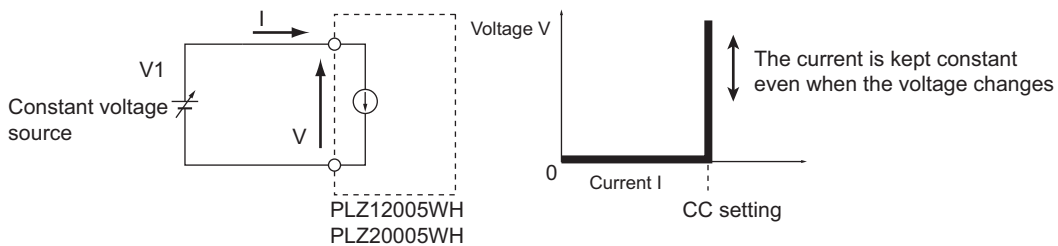

### Transition of the operating point: Overpower protection (OPP) operation

Example: Examining the load characteristics of the constant-voltage power supply in CC mode.

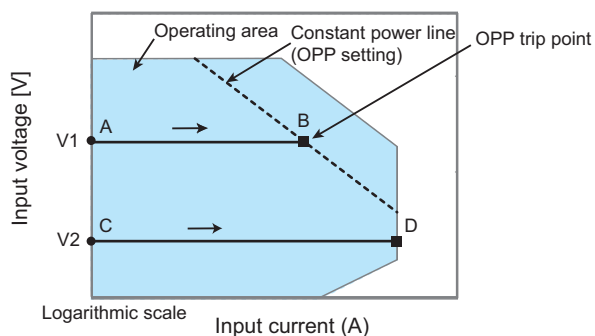

#### ■ Operation on segment AB

If the voltage of the constant-voltage power supply is set to  $V_1$  and the input current (load current) of the product is increased, the operating point moves along segment AB. When point B is reached, overpower protection (OPP) is activated. At this point, two types of operation are available on the product depending on which action is set to be executed at OPP detection.

Setup	Behavior
Trip	Turns off the load (stops the current flow).
Limit	The product sinks current as a constant power load at point B. Even if you attempt to increase the input current, the current is limited at point B. If you decrease the input current, the OPP is cleared. The product returns to CC mode and the operating point moves along segment AB.

#### ■ Operation on segment CD

If the voltage of the constant-voltage power supply is set to  $V_2$  and the input current (load current) of the product is increased, the operating point moves along segment CD. Point D is maximum current.



## Operation in constant resistance (CR) mode

### Operation in constant resistance mode

When the product is used in CR mode, it operates as a constant resistance load as shown in the following figure. When voltage  $V_1$  of the constant-voltage power supply varies, the product sinks current to maintain  $I = V/R$ , with the specified resistance  $R$  fixed. The product operates by sinking current. This mode cannot be used with an AC circuit.

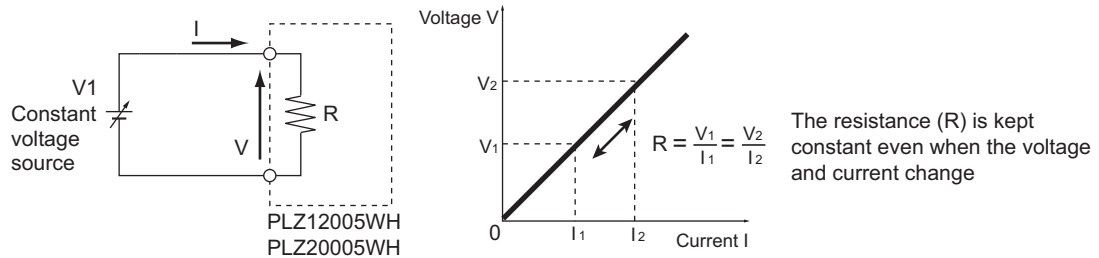

### Transition of the operating point: Overpower protection (OPP) operation

Example: Examining the load characteristics of the constant-voltage power supply in CR mode.

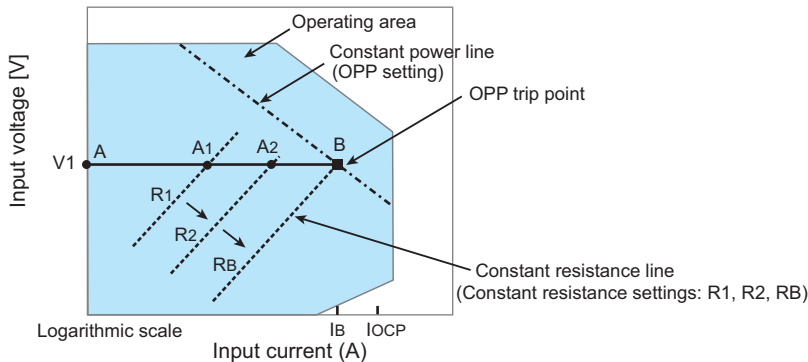

If the overcurrent protection (OCP) setting  $IOCP$  is greater than the current value  $IB$  at point B, when the product resistance is decreased ( $R_1 \rightarrow R_2 \rightarrow R_B$ ) and the input current (load current) is increased with the voltage of the constant-voltage power supply at  $V_1$ , the operating point moves along segment AB ( $A_1 \rightarrow A_2 \rightarrow B$ ). When point B is reached, OPP is activated. At this point, two types of operation are available on the product depending on which action is set to be executed at OPP detection.

Setup	Behavior
Trip	Turns off the load (stops the current flow).
Limit	The product sinks current as a constant power load at point B. Even if you attempt to increase the input current by decreasing the resistance, the current is limited at point B. If you decrease the input current by increasing the resistance, the OPP is cleared. The product returns to CR mode, and the operating point moves along segment AB.

### Transition of the operating point: Overcurrent protection (OCP) operation

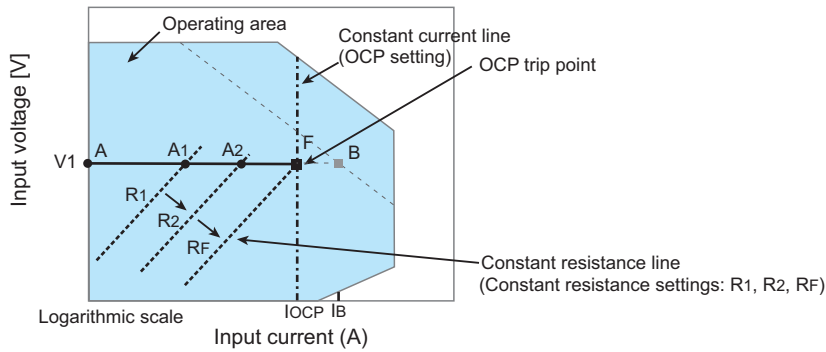

If the OCP setting  $I_{OCP}$  is smaller than the current value  $I_B$  at point B, when the product resistance is decreased ( $R_1 \rightarrow R_2 \rightarrow R_F$ ) and the input current (load current) is increased with the voltage of the constant-voltage power supply at  $V_1$ , the operating point moves along segment AF ( $A_1 \rightarrow A_2 \rightarrow F$ ). When point F is reached, OCP is activated. At this point, two types of operation are available on the product depending on which action is set to be executed at OCP detection.

Setup	Behavior
Trip	Turns off the load (stops the current flow).
Limit	The product sinks current as a constant current load at point F. Even if you attempt to increase the input current by decreasing the resistance, the current is limited at point F. If you decrease the input current by increasing the resistance, the OCP is cleared. The product returns to CR mode, and the operating point moves along segment AF.

## Constant power (CP) mode operation

### Constant power mode operation

When the product is used in CP mode, the product operates as a constant power load as shown in the following figure. When voltage  $V_1$  of the constant-voltage power supply increases, input current  $I$  decreases so that the power consumed by the product,  $P=V \times I$ , is kept constant. In the following figure,  $P = V_1 \times I_1 = V_2 \times I_2$ .

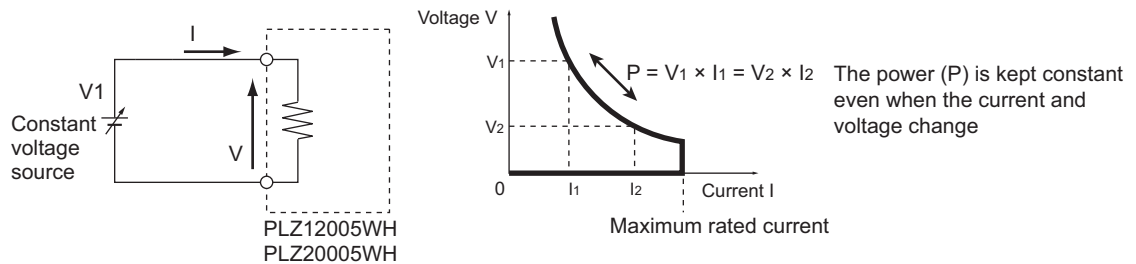

### Transition of the operating point: Overcurrent protection (OCP) operation

Example: Examining the load characteristics of the constant-voltage power supply in CP mode.

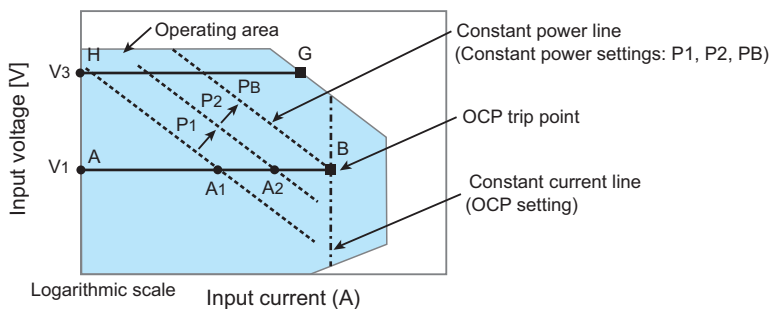

#### ■ Operation on segment AB

If the voltage of the constant-voltage power supply is set to  $V_1$  and the power of the product is increased ( $P_1 \rightarrow P_2 \rightarrow P_B$ ) and the input current (load current) is increased, the operating point moves along segment AB ( $A_1 \rightarrow A_2 \rightarrow B$ ). When point B is reached, OCP is activated. At this point, two types of operation are available on the product depending on which action is set to be executed at OCP detection.

Setup	Behavior
Trip	Turns off the load (stops the current flow).
Limit	The product sinks current as a constant current load at point B. Even if you attempt to increase the input current, the current is limited at point B. If you decrease the input current, the OCP is cleared. The product returns to CP mode and the operating point moves along segment AB.

#### ■ Operation on segment GH

If the voltage of the constant-voltage power supply is set to  $V_3$  and the power of the product is increased ( $P_1 \rightarrow P_2 \rightarrow P_B$ ) and the input current (load current) is increased, the operating point moves along segment GH. Point G is maximum power.

## Constant voltage (CV) mode operation

In CV mode, the product sinks current so that the voltage at the load input end of the product is constant.

### Constant voltage mode operation

When the product is used in CV mode, the product operates as a constant voltage load (shunt regulator) as shown in the following figure. When  $V_1$  is greater than  $V$ , input voltage  $V$  is kept constant even when input current  $I$  varies. Current does not flow when  $V_1$  is less than or equal to  $V$ . The product may operate unstably if  $R_1$  is low.

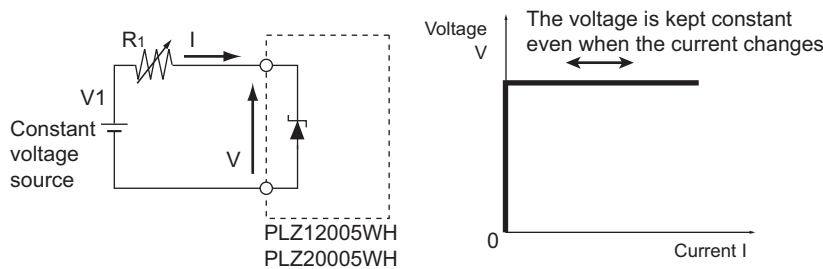

### Transition of the operating point: Overpower protection (OPP) operation

Example: Examining in CV mode the load characteristics of the power supply with a large internal resistance

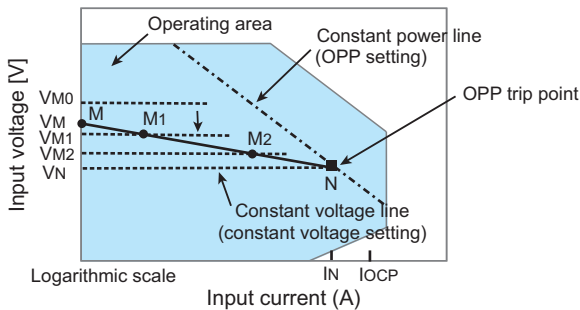

We assume that the overcurrent protection setting  $IOCP$  is greater than current  $IN$  at point  $N$  and denote the voltage of the constant voltage power supply as  $VM$ . When voltage  $VM_0$  of the product is greater than  $VM$ , no current flows. When the voltage of the product is decreased to a point where  $VM_0$  is smaller than  $VM$ , the current starts flowing. If the voltage is decreased further ( $VM_1 \rightarrow VM_2 \rightarrow VN$ ) to increase the input current (load current), the operating point moves along segment  $MN$  ( $M_1 \rightarrow M_2 \rightarrow N$ ). When point  $N$  is reached, OPP is activated. At this point, two types of operation are available on the product depending on which action is set to be executed at OPP detection.

Setup	Behavior
Trip	Turns off the load (stops the current flow).
Limit	The product sinks current as a constant power load at point $N$ . Even if you attempt to decrease the voltage, the current is limited at point $N$ . If you increase the voltage, the OPP is cleared. The product returns to CV mode and the operating point moves along segment $MN$ .

## Transition of the operating point: Overcurrent protection (OCP) operation

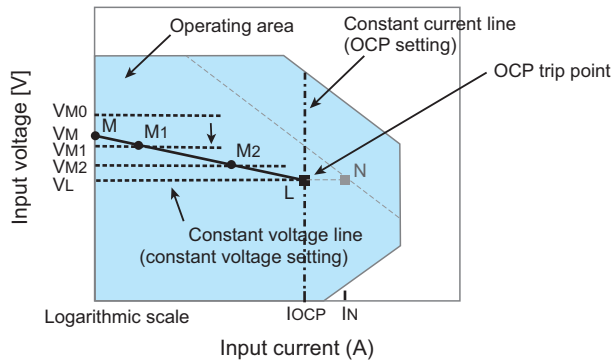

We assume that OCP setting  $I_{OCP}$  is smaller than current  $I_N$  at point N and denote the voltage of the constant voltage power supply as  $V_M$ . When voltage  $V_{M0}$  of the product is greater than  $V_M$ , no current flows. When the voltage of the product is decreased to a point where  $V_{M0}$  is smaller than  $V_M$ , the current starts flowing. If the voltage is decreased further ( $V_{M1} \rightarrow V_{M2} \rightarrow V_L$ ) to increase the input current (load current), the operating point moves along segment ML ( $M1 \rightarrow M2 \rightarrow L$ ). When point L is reached, OCP is activated. At this point, two types of operation are available on the product depending on which action is set to be executed at OCP detection.

Setup	Behavior
Trip	Turns off the load (stops the current flow).
Limit	The product sinks current as a constant current load at point L. Even if you attempt to decrease the voltage current, the current is limited at point L. If you increase the voltage, the OCP is cleared. The product returns to CV mode and the operating point moves along segment ML.

## Operating area of each model

### Operating area of PLZ12005WH

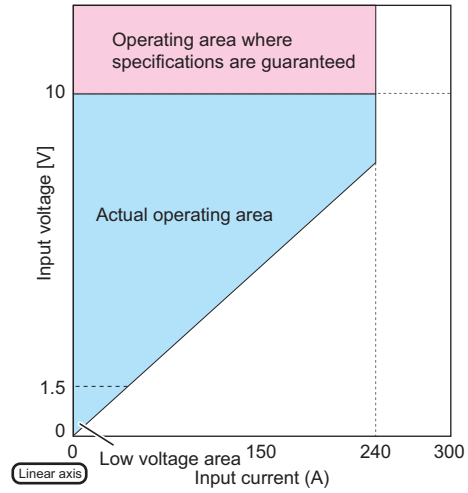
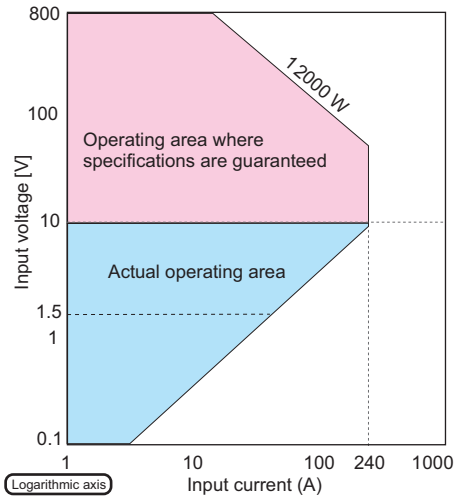

### Operating area of PLZ20005WH

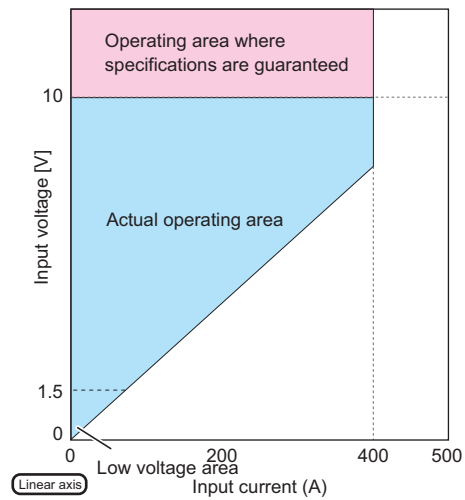
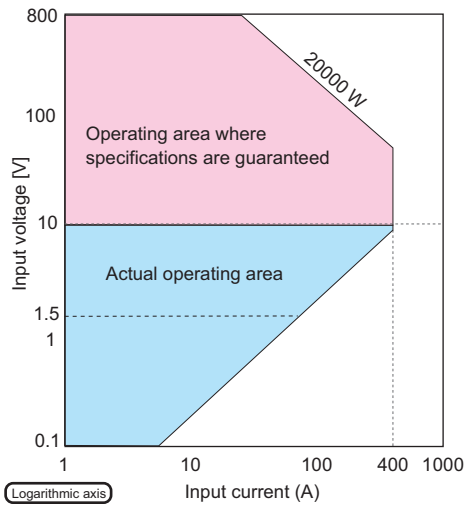

# Response Time and Waveform When an OPP Is Activated

This product sets power limits and current limits using a load input terminal voltage of 100 V as a threshold. If the voltage is 100 V or less, it is possible to run up to the specified current instantaneously even when the load power exceeds the rated power. If the voltage exceeds 100 V, the current is limited as shown in the following graph regardless of the specified current.

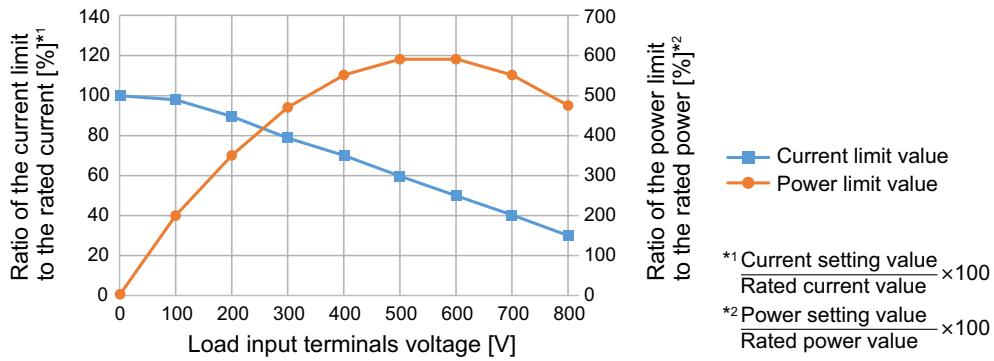

The OPP response time varies depending on the amplitude of the load power and the amplitude of the load current exceeding the OPP setting. This section indicates the response time and waveform when the action to be performed on activation is set to Limit (OPPL).

## Response time

The relationship between the time until an OPP is activated and the load input terminals voltage in CC mode is indicated below.

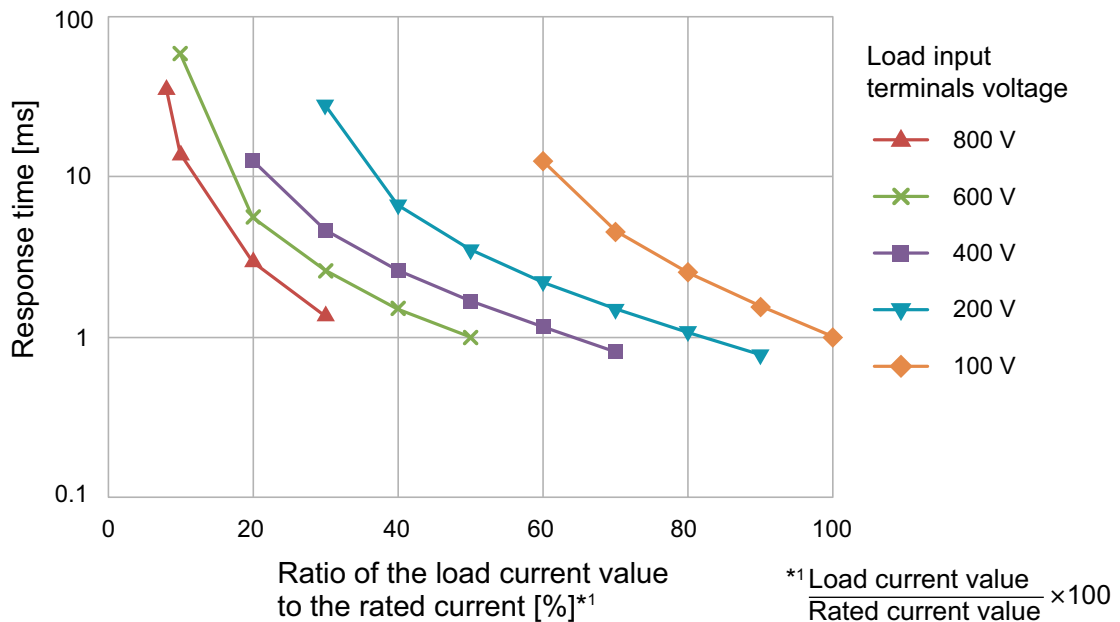

## Waveform

### ■ Load power 48000 W

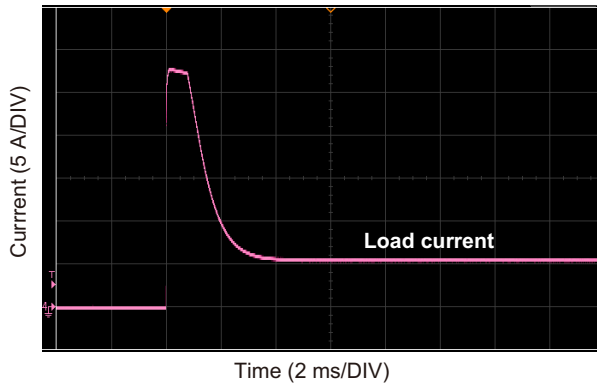

Measuring conditions

- Operation mode: CC
- Load current: 0 A → 120 A
- Load input terminals voltage: 400 V

### ■ Load power 96000 W

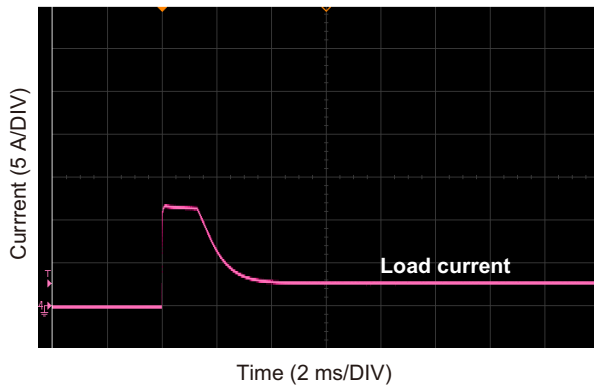

Measuring conditions

- Operation mode: CC
- Load current: 0 A → 120 A
- Load input terminals voltage: 800 V



# Propagation Delay for External Control

The following figure shows the propagation delays of the changes in the load current with respect to external control and the changes in the current monitor voltage with respect to changes in the load current.

## External input voltage (EXT CONT) versus load current

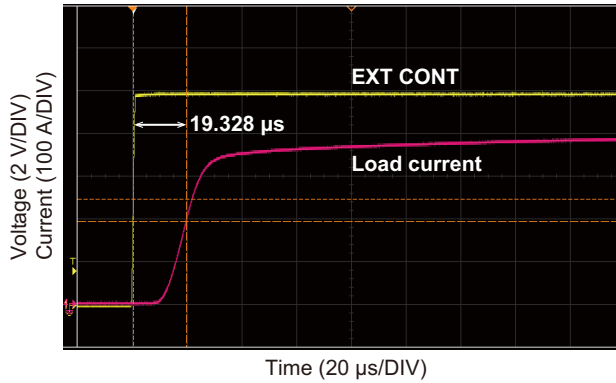

Measuring conditions

- Operation mode: CC
- Load current: 0 A → 400 A
- Load input terminals voltage: 50 V
- Slew rate: 20 A/μs
- EXT CONT signal (external input voltage): 0 V → 10 V

## Load current versus current monitor voltage (I MON OUT)

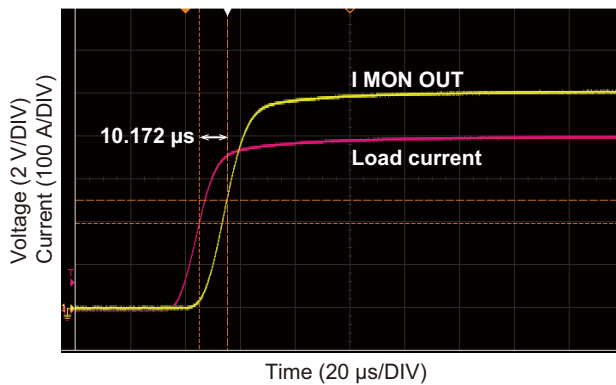

Measuring conditions

- Operation mode: CC
- Load current: 0 A → 400 A
- Load input terminals voltage: 50 V
- Slew rate: 20 A/μs

# Operating Range during Parallel Operation

The operating range during parallel operation using the same model is shown for each operation mode.

## CC mode

### ■ Operating range

Number of slaves	PLZ12005WH	PLZ20005WH
1	0 A to 480 A	0 A to 800 A
2	0 A to 720 A	0 A to 1200 A
3	0 A to 960 A	0 A to 1600 A
4	0 A to 1200 A	0 A to 2000 A

### ■ Slew rate

Number of slaves	PLZ12005WH	PLZ20005WH
1	0.02 A/μs to 24 A/μs	0.04 A/μs to 40 A/μs
2	0.03 A/μs to 36 A/μs	0.06 A/μs to 60 A/μs
3	0.04 A/μs to 48 A/μs	0.08 A/μs to 80 A/μs
4	0.05 A/μs to 60 A/μs	0.1 A/μs to 100 A/μs

## CR mode

### ■ Operating range

Number of slaves	PLZ12005WH		PLZ20005WH	
	H range	L range	H range	L range
1	12 S to 0 S	120 mS to 0 S	20 S to 0 S	200 mS to 0 S
2	18 S to 0 S	180 mS to 0 S	30 S to 0 S	300 mS to 0 S
3	24 S to 0 S	240 mS to 0 S	40 S to 0 S	400 mS to 0 S
4	30 S to 0 S	300 mS to 0 S	50 S to 0 S	500 mS to 0 S

## CV mode

### ■ Operating range

Number of slaves	PLZ12005WH	PLZ20005WH
1 to 4	10 V to 800 V	

## CP mode

### ■ Operating range

Number of slaves	PLZ12005WH	PLZ20005WH
1	0 W to 24 kW	0 W to 40 kW
2	0 W to 36 kW	0 W to 60 kW
3	0 W to 48 kW	0 W to 80 kW
4	0 W to 60 kW	0 W to 100 kW

# Options

---

This product has the following options.  
For information about options, contact your Kikusui agent or distributor.

## Parallel operation signal cable kit (PC02-PLZ-5W)

---

This kit contains a signal cable for performing parallel operation on the PLZ12005WH/PLZ20005WH.  
Cable length: Approx. 1 m

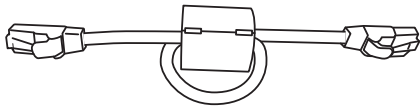

## Low inductance cable

---

This is a load cable with suppressed inductance. It suppresses voltage drops that occur when current fluctuations are fast.

## GPIB converter (PIA5100)

This converter converts RS232C or USB of the product to GPIB, enabling connection of a remote controller using GPIB. Perform the connection as shown below.

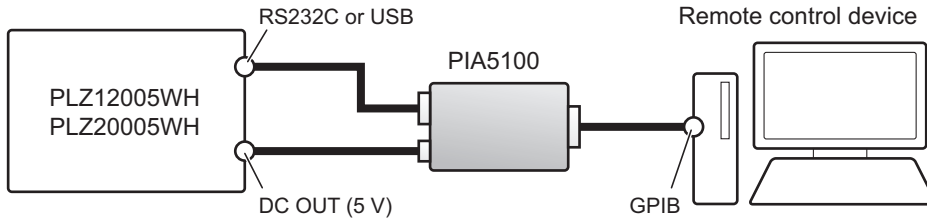

The GPIB communication specifications are as follows.

Item	Specifications
Hardware	Complies with IEEE Std 488.1-1987 SH1, AH1, T6, L4, SR1, PP0, DC1, DT1, C0, E1
Message terminator	LF or EOI during reception, LF + EOI during transmission
Primary address	0 to 30

When you connect a PIA5100, you cannot use the product's RS232C or USB port.

Some restrictions apply to the GPIB functions that can be used with the PIA5100. When connected through RS232C, the product supports the KISTD SAFU protocol.

For details, see the GPIB converter (PIA5100) operation manual.

## Rack mount bracket

These are rack mounting options.

Name	Model	Appropriate Model	Description
Rack mount bracket	KRB9	PLZ12005WH	For EIA inch racks
	KRB400-PCR-LE		For JIS millimeter racks
Rack mount bracket	KRB13	PLZ20005WH	For EIA inch racks
	KRB600		For JIS millimeter racks

To rack mount the product, remove the casters and the stopper.

## Attaching rack mount brackets

For information on rack mounting, see the manual of the rack mount bracket.

### ■ PLZ12005WH

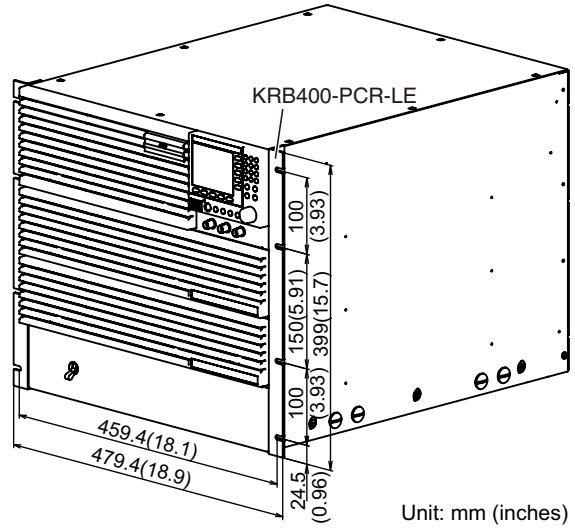
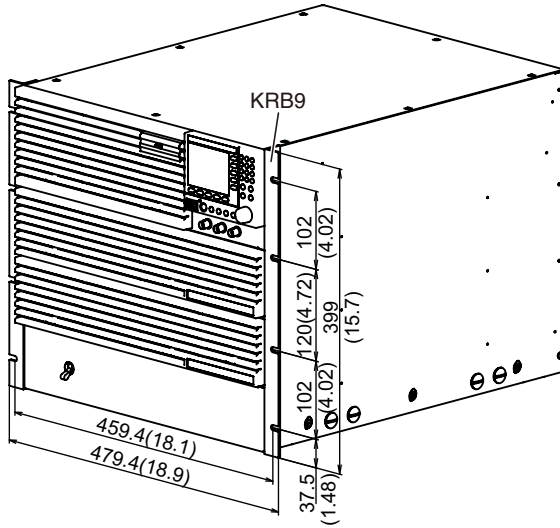

Unit: mm (inches)

### ■ PLZ20005WH

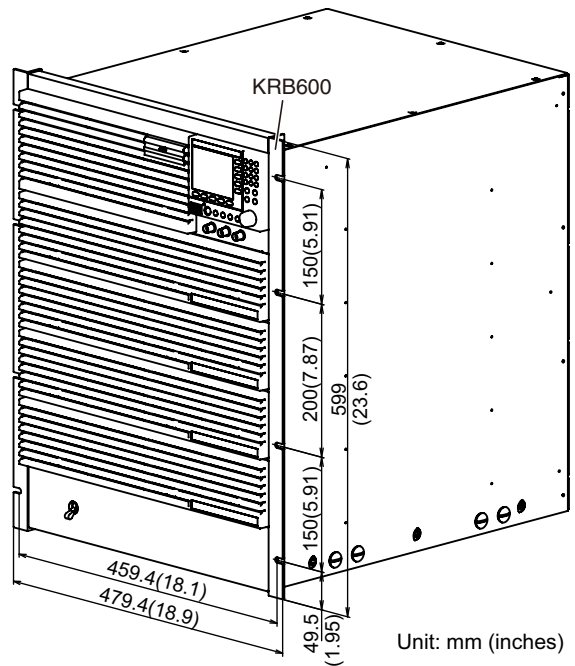
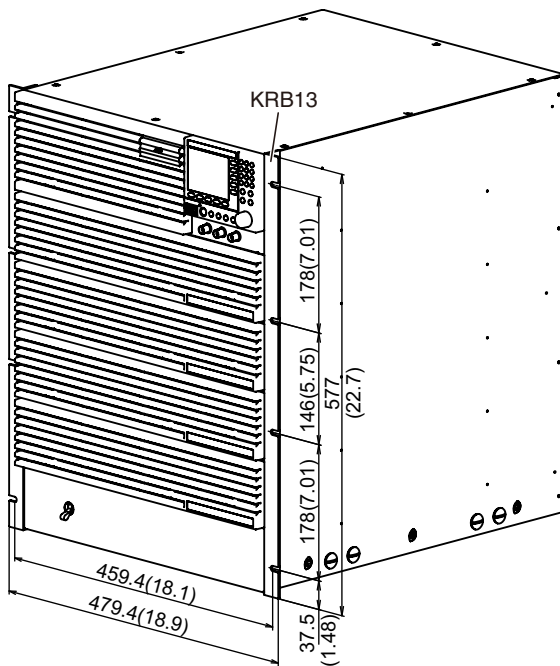

Unit: mm (inches)

## Removing the handles, casters, and stopper

**NOTE** We recommend that you keep all pieces that you remove from the product. You will need these pieces if you remove the product from the rack.

- 1** While pulling down the stopper (one location) of the bottom panel, loosen the screws with a screwdriver and remove it.
- 2** While pulling down the casters (four locations) of the bottom panel, loosen the screws with a screwdriver and remove them.
- 3** While pulling toward you the handles (two locations) of the side panels, loosen the screws with a screwdriver and remove them.

### ■ PLZ12005WH example

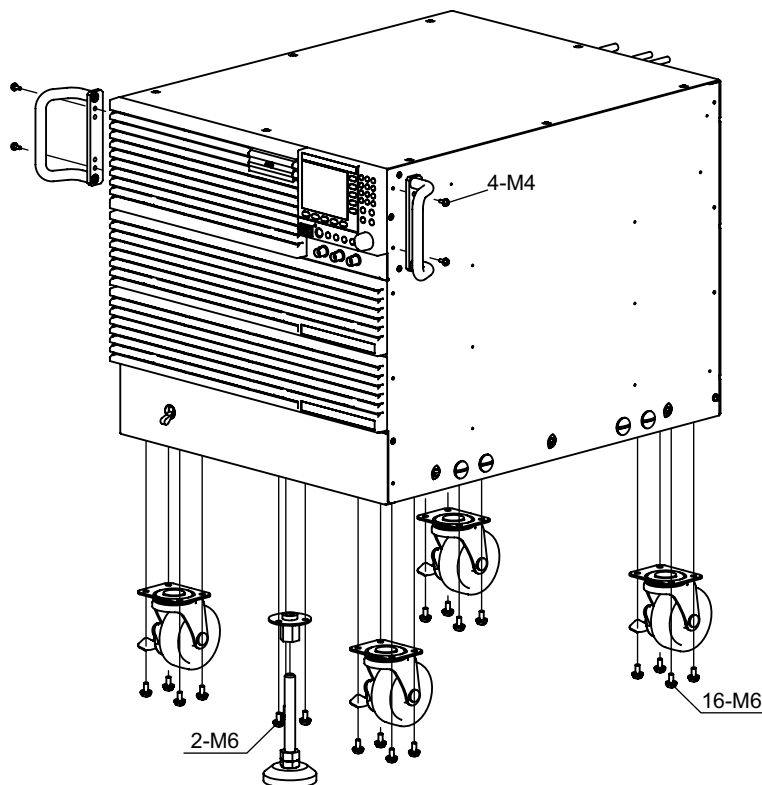

# Troubleshooting

This section introduces troubleshooting measures. Typical symptoms are listed. Check whether any of the items listed below apply to your case. In some cases, the problem can be solved quite easily.

If none of the items apply to your case, we recommend that you initialize the product to its factory default settings (p. 127). If following the remedy does not solve your problem, contact your Kikusui agent or distributor.

## ■ Nothing appears on the display when the POWER switch is turned on.

Check item	Possible cause	Remedy
Is the rated voltage being applied to the input power supply (AC)?	Broken power cord. Bad connection at the AC INPUT connector on the rear panel.	Check that the power cord is not broken and that the connection at the AC INPUT connector is secure.

## ■ Keys do not work.

Check item	Possible cause	Remedy
Are the keys locked? (🔒 is shown on the display)	The key lock is enabled (p. 119).	Hold down ENTER to unlock the keys.

## ■ Input current is unstable or oscillates.

Check item	Possible cause	Remedy
Is the rated voltage being applied to the input power supply (AC)?	Low supply voltage.	Use the product in the input supply voltage range.
Is an alarm occurring?	There is an internal or external error.	Check the type of alarm, and eliminate the root cause of the alarm. (p. 40).
Is there a large loop in the load cable?	The wire inductance has increased.	Twist the wires. See "Preventing large voltage variation when load current changes suddenly" (p. 148).
Does the behavior change depending on the length of the wiring?	A proper response speed is not being used.	Change the response speed (p. 57).

## ■ An alarm is occurring.

Check item	Possible cause	Remedy
Has overheat detection (OTP) been activated?	The fan has stopped.	Immediately stop using the product, and have it repaired.
	Vent or inlet holes are blocked.	Move the product so that there is at least 20 cm of space between the vents and the surrounding walls. Do not place objects within 20 cm of the vents.
Has overcurrent protection (OCP) been activated?	The OCP setting is small.	Set an appropriate OCP value on the setup screen (p. 42).
Has overpower protection (OPP) been activated?	The OPP setting is small.	Set an appropriate OPP value on the setup screen (p. 43).

### ■ The load cannot be turned on.

Check item	Possible cause	Remedy
A sequence is in operation.	The load cannot be turned on manually when a sequence is in operation.	Wait for the sequence operation to finish. Abort the sequence by pressing the Abort key ( <a href="#">p.95</a> ).
Is the load on/off logic (Input Logic) set to Negative?	The logic is incorrect.	Set Input Logic to Positive ( <a href="#">p.105</a> ).
Are you using an external signal to turn the load off?	When the load is turned off through external control, the LOAD key is invalid.	The load key will be valid after you use an external signal to turn the load on ( <a href="#">p.105</a> ).

### ■ The load suddenly turns off.

Check item	Possible cause	Remedy
Is the elapsed time cutoff function enabled?	The elapsed time cutoff function was activated.	Set the elapsed time cutoff function to Disable ( <a href="#">p.62</a> ).
Is another cutoff function enabled?	The other cutoff function was activated.	Set the other cutoff function to Disable ( <a href="#">p.62</a> ).

### ■ External control (CC/CR/CP) cannot be set.

Check item	Possible cause	Remedy
The pulse function is on.	Cannot be used simultaneously with the pulse function.	Turn off the pulse function ( <a href="#">p.36</a> ).
The sine function is on.	Cannot be used simultaneously with the sine function.	Turn off the sine function ( <a href="#">p.39</a> ).

### ■ Pulse function of sine function cannot be set.

Check item	Possible cause	Remedy
External control (CC/CR/CP) is on.	Cannot be used simultaneously with the external control (CC/CR/CP).	Turn off the external control (CC/CR/CP) ( <a href="#">p.102</a> ).
A sequence is running.	Cannot be used simultaneously with a running sequence.	Abort the sequence ( <a href="#">p.95</a> ).



# Index

## A

ABC preset memories ..... 67  
accessories ..... 3  
alarm  
    occurrence ..... 46  
    type ..... 40  
ARB mode ..... 29  
arbitrary I-V characteristics mode 29

## B

battery replacement ..... 133  
beep sound ..... 120  
BNC connector ..... 142

## C

calibration ..... 133  
CC mode ..... 24, 152  
CLEAR key ..... 20  
clearing  
    alarms ..... 46  
communication function ..... 142  
component names ..... 8  
conductance ..... 25  
constant current mode ..... 24, 152  
constant power mode ..... 28, 155  
constant resistance mode .. 25, 153  
constant voltage mode ..... 27, 156  
CP mode ..... 28, 155  
CR mode ..... 25, 153  
current/voltage monitor signal... 110  
cursor keys ..... 20  
cutoff function ..... 62  
CV mode ..... 27, 156

## D

date/time setting ..... 126  
DC INPUT ..... 11, 13  
DC OUT 5V ..... 164  
default settings ..... 129  
device information ..... 132  
digital I/O ..... 109  
DIGITAL0 ..... 109  
DIGITAL1 ..... 109  
DIGITAL2 ..... 109, 121  
display ..... 10  
DUT ..... 14  
Dwell ..... 87

## E

elapsed time display ..... 55  
ESCAPE key ..... 20  
EXT CONT connector ..... 100, 101  
EXT SYNC port ..... 75  
external control ..... 99  
external dimensions ..... 144

## F

factory default settings ..... 129  
factory default settings, restoring.... 124, 127  
firmware version ..... 132  
function keys ..... 18

## G

Generate ..... 88  
GPIB converter ..... 164

## H

humidity range ..... 143

## I

I MON OUT ..... 8, 110  
icons ..... 10  
Immediate ..... 87  
inrush current ..... 143  
integrated current display ..... 55  
integrated data ..... 53  
integrated power display ..... 55  
interface settings ..... 122  
IP address ..... 122, 132  
isolation voltage ..... 134, 140, 142

## K

KEY LOCK key ..... 120  
keyboard ..... 20

## L

Level ..... 87  
Load ..... 87  
load input terminal cover ..... 15  
load input terminals ..... 14  
LOAD key ..... 22  
load on/off ..... 22  
load value ..... 10  
LOCAL key ..... 79  
logging ..... 47

## M

malfunctions and causes ..... 167  
MEASURE key ..... 9, 17  
measurement ..... 47  
memory ..... 66  
Menu keys ..... 17

## N

numeric keypad ..... 20

## O

OCP ..... 42  
OCPL ..... 42  
OCPT ..... 42  
operating area ..... 151  
operation mode ..... 23  
OPP ..... 43, 159  
OPPL ..... 43  
OPPT ..... 43  
overcurrent protection ..... 42  
overhaul ..... 133  
overpower protection ..... 43, 159

## P

panel operation ..... 17  
panel settings at startup ..... 117  
PARALLEL connector ..... 113  
parallel operation ..... 111  
power consumption ..... 143  
power on/off ..... 13  
POWER switch ..... 13  
preset memory ..... 67  
program ..... 80, 81  
protection ..... 40, 83, 114  
protection plate ..... 100, 101  
pulse function ..... 34

## R

Rack mount brackets ..... 164  
Ramp ..... 87  
remote control ..... 79  
remote sensing ..... 59  
reset ..... 124, 128  
reset settings ..... 129  
response speed ..... 57  
restart ..... 114  
rotary knob ..... 20

## S

-S.....	59
+S.....	59
Sanitize .....	127
SCPI error .....	125
screen saver.....	118
sensing cable .....	60
sequence.....	80, 94
SEQUENCE key .....	9, 17
sequence tutorial.....	90
serial number .....	11
setup memory .....	70
sine function .....	37
slew rate.....	33, 150
soft start .....	58
SOURCE key .....	9, 17
specifications.....	134
SR .....	87
step .....	80, 86
stopper, locking.....	4
synchronized operation .....	74
SYSTEM key.....	9, 17
system settings .....	116

## T

temperature range.....	143
time setting.....	126
time zone.....	126
TRIG OUT .....	108
trigger .....	48, 87, 95
trigger input/output .....	108
troubleshooting.....	167

## U

undervoltage protection.....	44
updating .....	131
USB.....	8, 20, 131
UVP.....	44
UVPL.....	44
UVPT.....	44

## V

V MON OUT .....	8, 110
version.....	132

## W

Wait (post).....	88
Wait (pre) .....	87
watchdog protection .....	45
WDP .....	45
weight.....	143



If you find any misplaced or missing pages in the manuals, they will be replaced. If the manual gets lost or soiled, a new copy can be provided for a fee. In either case, please contact your Kikusui agent or distributor. At that time, inform your agent or distributor of the "Part No." written on the front cover of this manual.

Every effort has been made to ensure the accuracy of this manual. However, if you have any questions or find any errors or omissions, please contact your Kikusui agent or distributor.

After you have finished reading this manual, store it so that you can use it for reference at any time.

## **KIKUSUI ELECTRONICS CORP.**

---

1-1-3 Higashiyamata, Tsuzuki-ku, Yokohama,  
224-0023, Japan

Phone: +81-45-482-6353

Facsimile: +81-45-482-6261

**[www.kikusui.co.jp/en/](http://www.kikusui.co.jp/en/)**

