

Setup Guide

PCR-LE series Parallel Operation Driver

PD05M-PCR-LE PD05S-PCR-LE

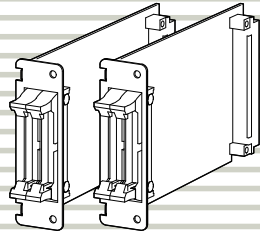

Thank you for purchasing the PCR-LE Series Parallel operation driver.

This option is used to perform master-slave parallel operation on the PCR-LE Series AC power supplies (excluding the PCR500LE and PCR1000LE; up to 5 units (power is 27 kVA or less)). Parallel operation is possible between different PCR-LE models as long as the number of units is 5 or less (power is 27 kVA or less).

The PD05M-PCR-LE is used on the master unit.

The PD05S-PCR-LE is used on slave units.

Number of PCR-LE operated in parallel	Number of PD05M-PCR-LE (for master)	Number of PD05S-PCR-LE (for slave)
2	1	1
3	1	2
4	1	3
5	1	4

Features

- Enabling PCR-LE AC Power Supplies to Generate Large-capacity, Multifunctional High-quality Output
Using this product in combination with 2P05-PCR-LE single-phase, three-wire output drivers or 3P05-PCR-LE three-phase output drivers creates a high capacity, multi-phase output AC power supply.
- Expansion of Output Capacity in the Future or Temporarily (economical equipment investment)
Use of the Parallel Operation Driver allows expansion of the output capacity if a PCR-LE is small capacity and the capacity is to be increased later. Alternatively, PCR-LE installed singly can be integrated for use if they are generally used at small capacity, but a large capacity is required due to provisional testing or the like.

KIKUSUI ELECTRONICS CORP.

www.kikusui.co.jp

©2012 KIKUSUI Electronics Corp.

Check at Unpacking

Upon reception of the product, confirm that the package contains the necessary accessories and that the device and accessories have not been damaged during transportation. If the device is damaged or any accessory is missing, notify Kikusui distributor/agent.

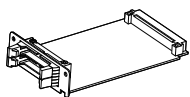

PD05M-PCR-LE or PD05S-PCR-LE (1pc.)

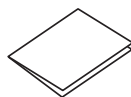

Setup Guide (This sheet, 1pc.)

PD05M-PCR-LE only



Protection sockets (2 pcs.) [84-49-0110]

PD05S-PCR-LE only

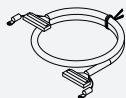

Connecting cable (70 cm, 1pc.) [91-88-0180]

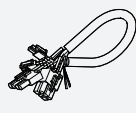

Power signal cable (30 cm, 1pc.) [91-88-0182]

Functional limitations during parallel operation

You will not be able to use the following features when you install this product.

Power-saving function (only when performing parallel operation using different models)

High speed response setting (FAST)

Firmware version of PCR-LE

When using the PD05M-PCR-LE/ PD05S-PCR-LE, the PCR-LE must be required with the firmware version of 3.00 or later. If the firmware version of the PCR-LE is 2.99 or previous version, the PCR-LE is required for the firmware update.

When using the PD05M-PCR-LE/ PD05S-PCR-LE, the firmware of all the PCR-LE series that make up the system must be the same.

To check the firmware version of the PCR-LE, refer to the operation manual of the PCR-LE series. In case, the PCR-LE needs update, contact your Kikusui agent or distributor.

Handling Precautions

■ Handling of the boards

- Ground yourself by touching a grounded metal object before touching the board.
- Avoid handling the interface board in an environment subject to strong static electricity.
- For storage, provide electrostatic protection measures such as the anti-static bag accompanying the interface board.
- Do not drop a board or subject it to other impact.
- Do not install or uninstall the interface board with the power ON of the PCR-LE Series.

■ Handling of the cables

- Do not damage the cable.
- Do not pull, bend, or apply any other stress to the cable.

Setting the Addresses

First, set the PD05M-PCR-LE and PD05S-PCR-LE addresses. Use the dip switches on the boards to set the addresses.

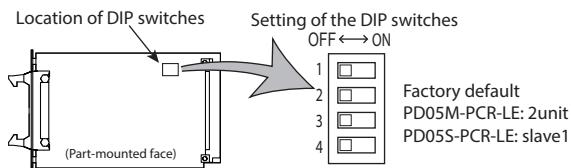

- Setting the address of Master (PD05M-PCR-LE)

The master unit address varies depending on the number of units in parallel operation.

Number of PCR-LE in parallel	2 Units	3 Units	4 Units	5 Units
DIP-Switch Settings	OFF ↔ ON	OFF ↔ ON	OFF ↔ ON	OFF ↔ ON
	1 <input type="checkbox"/>	1 <input type="checkbox"/>	1 <input type="checkbox"/>	1 <input type="checkbox"/>
	2 <input type="checkbox"/>	2 <input type="checkbox"/>	2 <input type="checkbox"/>	2 <input type="checkbox"/>
	3 <input type="checkbox"/>	3 <input type="checkbox"/>	3 <input type="checkbox"/>	3 <input type="checkbox"/>
	4 <input type="checkbox"/>	4 <input type="checkbox"/>	4 <input type="checkbox"/>	4 <input type="checkbox"/>

- Setting the address of slave (PD05S-PCR-LE)

The slave numbers have no bearing on the placement of the power supplies.

	Slave1	Slave2	Slave3	Slave4
DIP-Switch Settings	OFF ↔ ON	OFF ↔ ON	OFF ↔ ON	OFF ↔ ON
	1 <input type="checkbox"/>	1 <input type="checkbox"/>	1 <input type="checkbox"/>	1 <input type="checkbox"/>
	2 <input type="checkbox"/>	2 <input type="checkbox"/>	2 <input type="checkbox"/>	2 <input type="checkbox"/>
	3 <input type="checkbox"/>	3 <input type="checkbox"/>	3 <input type="checkbox"/>	3 <input type="checkbox"/>
	4 <input type="checkbox"/>	4 <input type="checkbox"/>	4 <input type="checkbox"/>	4 <input type="checkbox"/>

- Configuration example for parallel operation of three units (including the master unit)

Configure PD05M-PCR-LE for three units. Set the first PD05S-PCR-LE to slave 1 (factory default setting) and the second PD05S-PCR-LE to slave 2.

Installing the board on the PCR-LE

The PCR-LE that has the PD05M-PCR-LE installed is the master unit; the PCR-LEs that have the PD05S-PCR-LEs installed are the slave units. When performing parallel operation using different PCR-LE Series models, set the model with the largest capacity to the master unit.

- Check that the POWER switch of PCR-LE is off.**
- Touch a grounded metal object (for example, the metal parts of the PCR-LE rear panel) to discharge any static electricity from your body.**
- Remove the screws that are holding the SLOT 2 cover in place on the rear panel, and remove the cover from the panel.**
- Hold the panel parts of the board so that the printed circuit board side is facing up.**
- Insert the board into the slot so that the printed circuit board's connector is inserted into the connector at the back of the slot.**
- Insert the board all the way into the slot.**
- Use the screws that you removed in step 3 to fix the board in place in the panel.**
- Follow the same procedure to install the other board.**
This completes installation of the parallel board.

Connecting the Boards

Use the master unit to control all the slave units. It is convenient to place the master unit in an easy-to-operate location.

Use the connecting cables to connect between boards and the power signal cables to connect the PCR-LEs so that they are as close to each other as possible (so that tension is not applied to the connecting cables).

The supplied connecting cable can be used when the master unit is placed on the left end or the right. To place the master unit in the center, the optional connecting cable (PC01-PCR-LE) is required.

The supplied power signal cable can be used when the master unit is placed on the left end. To place the master unit on the right end or in the center, the optional power signal cable (CC11-PCR-LE) is required.

Connecting the Boards

Use the connecting cable to connect between boards.

The PCR-LE that has the PD05M-PCR-LE will be the master unit, which will control the PCR-LEs that have the PD05S-PCR-LEs installed (slave units).

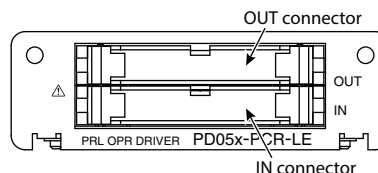

- Check that the POWER switch of PCR-LE is off.**
- Open the tab on the OUT connector of the master unit (PD05M-PCR-LE) and the IN connector of the slave unit (PD05S-PCR-LE), and securely connect the connecting cable.**
Insert the cable firmly so that the connector tab closes and the connector is locked.
- Connect the connecting cable shield to the attachment screw of each board.**

- To perform parallel operation with three or more units, connect all the PD05S-PCR-LEs in the same manner.**
Signals flow from the OUT connector to the IN connector. Make sure the IN and OUT connections are correct.
- Attach the protection sockets supplied with the PD05M-PCR-LE to the open connectors (master unit IN and slave unit OUT).**
This completes the procedure for connecting the boards.

⚠ WARNING

Risk of electric shock. The IN and OUT connectors contain pins that have the same potential as the output terminal. Be sure to attach protection sockets to open connectors.

Connecting PCR-LEs Together

First, connect PCR-LEs together with power signal cables. Then, connect the PCR-LE to the relay terminal board with output cables.

⚠ WARNING
Risk of electric shock.

- Before you connect cables to the connectors/terminals, be sure to turn the POWER switch off, and then remove the power plug from the outlet or turn off the switchboard.
- Do not use the terminal block with the terminal cover removed.

⚠ CAUTION
Risk of malfunction.

- Do not reverse the L and N polarities.
- The thickness (cross-sectional area) of the output cables to be used for this connection should be the same as that of the output cables for one PCR-LE power supply.

- Note -

To acquire stable measurements, be sure to use a relay terminal board to connect the load. The length of the cable between the PCR-LE to the relay terminal board must be 1 m or less.

1 Check that the POWER switches of PCR-LEs are off.

2 With a power signal cable, connect the J2 connector of the master unit to the J1 connector of the slave unit and the J4 connector of the master unit to the J3 connector of the slave unit.

The J1/ J2/ J3/ J4 connectors are on the rear panel. Insert the cable firmly into the connectors until they are locked in place.

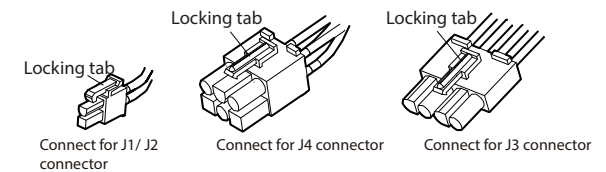
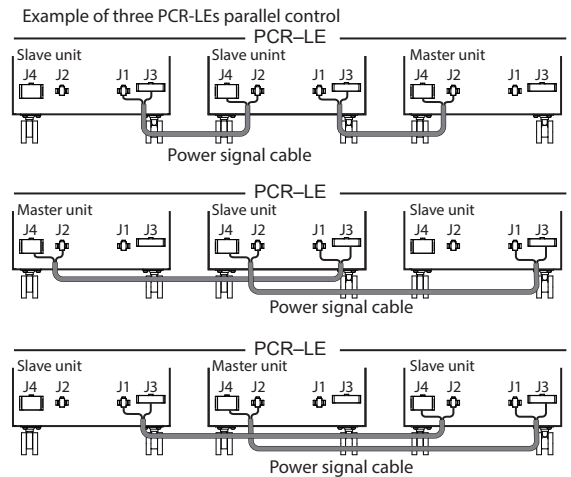

3 Connect all the remaining slave units in the same manner.

The signal flows from the J4 connector to the J3 connector and from the J2 connector to the J1 connector. This completes connection.

4 Connect the PCR-LE output terminal to the relay terminal board with output cables.

For detail of handling the terminal block tray, OUTPUT terminal block, and load wire, see the PCR-LE series setup guide.

The PCR-LE Series OUTPUT terminal block is wired after you first pull out the terminal block tray. The terminal box covers ensure that you don't touch the unwired terminals.

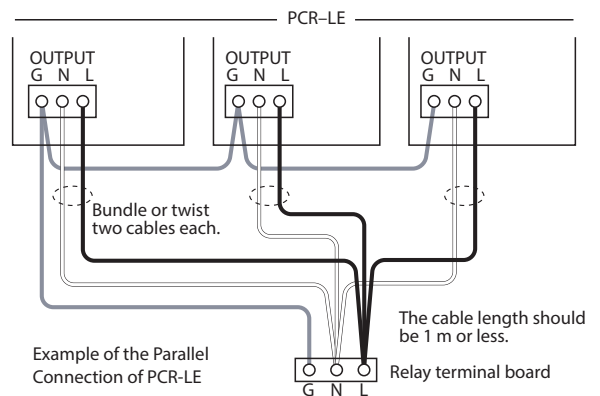

Turning the Power On

■ Power ON

Turn on the POWER switches on the master unit and all slave units within 10 seconds. Alternatively, turn the POWER switches of all PCR-LEs ON simultaneously.

The firmware version is displayed for a few seconds.

If there are no errors, the master unit displays the home position (the basic screen), and the slave units display "SLAVE-x" (where x is the slave unit number).

Master-slave parallel operation is controlled from the master unit. You cannot use the panel of the slave unit.

■ Power OFF

Turn off all POWER switches.

For emergency situations, we recommend that you insert a circuit breaker that separates the entire system from the switchboard.

Synchronizing the POWER Switches

You can configure the system so that when you turn on MASTER unit, all SLAVE units also turn on.

■ Power ON

- 1 Check that the POWER switches of PCR-LEs series are off.**
- 2 Set the POWER SELECTOR switch of the PCR-LE master unit to MASTER.**
The POWER SELECTOR switch is on the front panel.
- 3 Set the POWER SELECTOR switches of the other PCR-LEs to SLAVE.**
- 4 Turn ON the POWER switch of the PCR-LE slave units.**
Even when you turn ON the POWER switches, the PCR-LEs do not turn on.
- 5 Turn ON the POWER switch of the PCR-LE master unit.**
The PCR-LE slave units will also turn on.

- Note -

The power signal travels from the J2 connector to the J1 connector. Operating the POWER switch of the PCR-LE master unit will cause the other PCR-LEs to respond in sync.

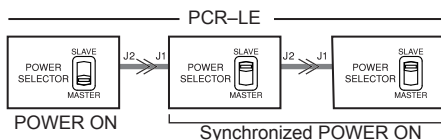

■ Power OFF

When you turn off the POWER switch on the master unit, all slave units power off in sync.

Power OFF in an Emergency

In an emergency, turn OFF all POWER switches.

■ To Stop Synchronization

Set the POWER SELECTOR switches of all PCR-LEs to "MASTER".

Operation Check

Check the operation of the PCR-LE series before you connect the load. Check the following items with no load connected. For detail of settings, see the PCR-LE series operation manual.

POWER switch ON

Voltage setting

OUTPUT ON/OFF

Voltage-range switching

If a trouble is occurring on even one unit, you will not be able to perform parallel operation.

Performing zero adjustment

When you perform master-slave parallel operation for the first time, current measurement offsets may appear in the current, power, power factor, and apparent power displays and the harmonic current analysis values (minute values are displayed under no-load conditions). To perform accurate measurements, perform zero adjustment.

To perform even more accurate measurements, with no load connected, wait 30 minutes after you turn the POWER switch on, and then perform zero adjustment.

- 1 Turn on the POWER switches on all PCR-LEs.**
- 2 Configure the master unit as follows:**
Output voltage mode: AC
Output voltage range: The desired range
AC voltage: 0 V
- 3 Turn on the output.**
- 4 Press CONFIG (SHIFT+OPR MODE), 1/2 (F6), and then CURR ADJ (F5). Press the START (F1) key.**
Zero adjustment starts.
When the zero adjustment is complete, "Measure Current ZERO Adjustment Finished" appears.
- 5 Press the OK (F4) key to end zero adjustment.**
To adjust a different output voltage range, turn off the output, change the output voltage range, and then repeat steps 3 to 5.

Once a zero adjustment is performed, as long as you do not change the connection, the PCR-LE remembers the calibration values for the master-slave parallel operation even when you turn off the POWER switch. If the ambient temperature changes, perform zero adjustment.

Connecting the Load

Connect the the relay terminal board to the load with output cables.

WARNING

Risk of electric shock. Before you connect cables to the terminals, be sure to turn the POWER switch off, and then remove the power plug from the outlet or turn off the switchboard.

CAUTION

Risk of malfunction.

- Do not reverse the L and N polarities.
- Use noncombustible cables with a thickness appropriate for the output current to connect from the relay terminal to the load.

Performing Master-Slave Parallel Operation

Master-slave parallel operation is controlled from the master unit.

The master unit displays the total output current of the system.

For details of settings, see the operation manual included with the PCR-LE series.

The screen captures used in the PCR-LE series operation manual are examples. They may differ from the screens that are displayed when you are setting parallel operation.

■ To Stop master-slave parallel operation

To quit master-slave parallel operation, turn off the power, remove the boards and power signal cables from the PCR-LE Series. Hold down the locking tab of the power-signal cable, and pull it free of the unit.

If the current limit setting on the master unit exceeds the rated current and you turn the POWER switch on after removing the board, the current limit will be changed to the maximum value for that PCR-LE alone.



环境保护使用期限
Environment-friendly Use Period

该标记为适用于在中华人民共和国销售的电子信息产品的环境保护使用期限。只要遵守有关该产品的安全及使用注意事项，从制造年月起计算，在该年度内，就不会对环境污染、人身、财产产生重大的影响。

产品的废弃请遵守有关规定。产品的制造年月可以在以下网址中确认。

<http://www.kikusui.co.jp/pi/>

毒有害物质或元素名称及含有标示

Name of hazardous materials and symbol of element in the equipment and quantity

有毒有害物质或元素					
铅 Pb	汞 Hg	镉 Cd	六价铬 Cr(VI)	多溴联苯 PBB	多溴二苯醚 PBDE
x	○	○	○	○	○

本表格依据 SJ/T 11364 的规定编制。

○：该部件所有均质材料的有毒有害物质的含量不超过 GB/T 26572 标准所规定的极限值要求。

×：该部件至少有一种均质材料的有毒有害物质的含量超过 GB/T 26572 标准所规定的极限值要求。