

Part No. Z1-001-902, IB002604

Jul. 2006

OPERATION MANUAL

AC Electronic Load

PCZ1000

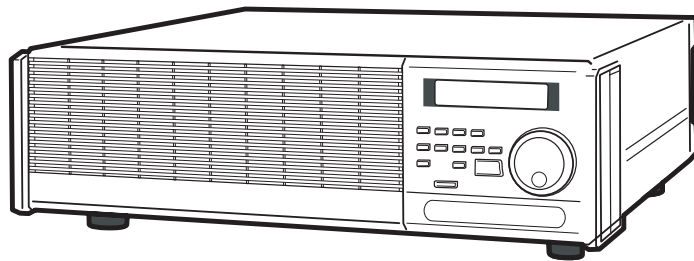

Use of Operation Manual

Please read through and understand this Operation Manual before operating the product. After reading, always keep the manual nearby so that you may refer to it as needed. When moving the product to another location, be sure to bring the manual as well.

If you find any incorrectly arranged or missing pages in this manual, they will be replaced. If the manual gets lost or soiled, a new copy can be provided for a fee. In either case, please contact Kikusui distributor/agent, and provide the “Kikusui Part No.” given on cover.

This manual has been prepared with the utmost care; however, if you have any questions, or note any errors or omissions, please contact Kikusui distributor/agent.

The contents of this Operation Manual may not be reproduced, in whole or in part, without the prior consent of the copyright holder.

The specifications of this product and the contents of this Operation Manual are subject to change without prior notice.

Power Requirements of this Product

Power requirements of this product have been changed and the relevant sections of the Operation Manual should be revised accordingly. (Revision should be applied to items indicated by a check mark ✓.)

Input voltage

The input voltage of this product is _____ VAC,
and the voltage range is _____ to _____ VAC.

Use the product within this range only.

Input fuse

The rating of this product's input fuse is _____ A, _____ VAC, and _____.

-
- ⚠ WARNING**
- To avoid electrical shock, always disconnect the AC power cord or turn off the switch on the switchboard before attempting to check or replace the fuse.
 - Use a fuse element having a shape, rating, and characteristics suitable for this product. The use of a fuse with a different rating or one that short circuits the fuse holder may result in fire, electric shock, or irreparable damage.
-

AC power cord

The product is provided with AC power cords described below. If the cord has no power plug, attach a power plug or crimp-style terminals to the cord in accordance with the wire colors specified in the drawing.

-
- ⚠ WARNING**
- The attachment of a power plug or crimp-style terminals must be carried out by qualified personnel.
-

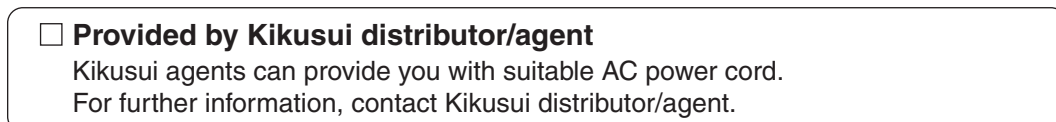
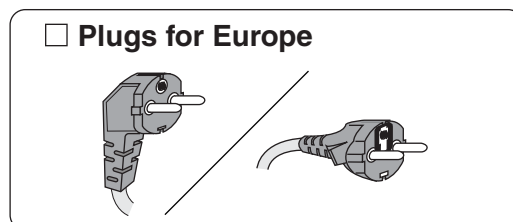
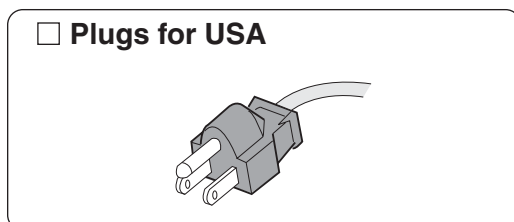
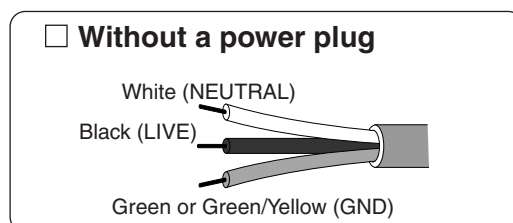
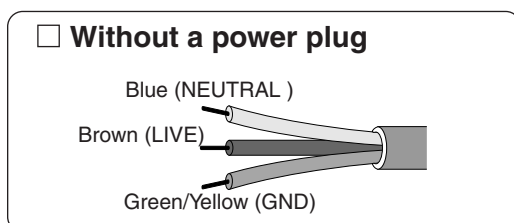

Before using the Remote Control

The RS-232C connector (signal lines) and the LOAD INPUT terminal of this instrument (the PCZ1000 that came with this manual) are insulated. However, they are not insulated on PCZ1000s that were manufactured before July 2006 (hereafter referred to as the old PCZ1000).

If you are controlling an old PCZ1000 from a PC via the RS-232C interface, the RS-232C cable may burn or the PC or the PCZ1000 may malfunction depending on how they are connected.

The RS-232C connector can be insulated from the LOAD INPUT terminal by altering the old PCZ1000. For details on the alteration, contact your Kikusui distributor/agent.

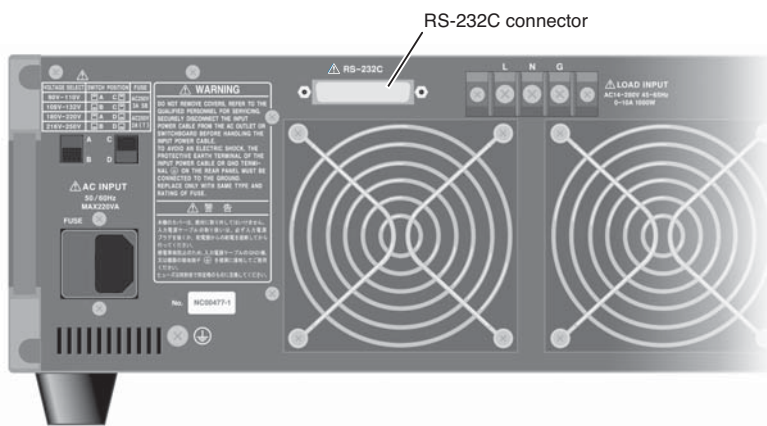

Safety Symbols

For the safe use and safe maintenance of this product, the following symbols are used throughout this manual and on the product. Understand the meanings of the symbols and observe the instructions they indicate (the choice of symbols used depends on the products).



Indicates that a high voltage (over 1,000 V) is used here. Touching the part causes a possibly fatal electric shock. If physical contact is required by your work, start work only after you make sure that no voltage is output here.

DANGER

Indicates an imminently hazardous situation which, if ignored, will result in death or serious injury.



Indicates a potentially hazardous situation which, if ignored, could result in death or serious injury.



Indicates a potentially hazardous situation which, if ignored, may result in damage to the product and other property.



Shows that the act indicated is prohibited.



Is placed before the sign “DANGER,” “WARNING,” or “CAUTION” to emphasize these. When this symbol is marked on the product, see the relevant sections in this manual.



Indicates an earth ground terminal.



Indicates a chassis ground terminal.

Safety Precautions

The following safety precautions must be observed to avoid fire hazard, electrical shock, accidents, and other failures. Keep them in mind and make sure that all of them are observed properly.



Users

- This product must be used only by qualified personnel who understand the contents of this operation manual.
- If it is handled by disqualified personnel, personal injury may result. Be sure to handle it under supervision of qualified personnel (those who have electrical knowledge.)

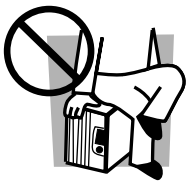

Purposes of use

- Do not use the product for purposes other than those described in the operation manual.

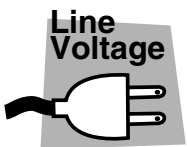

Input power

- Use the product with the specified input power voltage.
- For applying power, use the AC power cord provided. Note that the provided power cord is not use with some products that can switch among different input power voltages or use 100 V and 200 V without switching between them. In such a case, use an appropriate power cord. For details, see the relevant page of this operation manual.



Fuse

- With products with a fuse holder on the exterior surface, the fuse can be replaced with a new one. When replacing a fuse, use the one which has appropriate shape, ratings, and specifications.

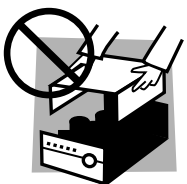

Cover

- There are parts inside the product which may cause physical hazards. Do not remove the external cover.

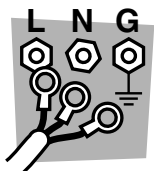

Installation

- When installing products be sure to observe "Precautions for Installation" described in this manual.
- To avoid electrical shock, connect the protective ground terminal to electrical ground (safety ground).
- When applying power to the products from a switchboard, be sure work is performed by a qualified and licensed electrician or is conducted under the direction of such a person.
- When installing products with casters, be sure to lock the casters.



Relocation

- Turn off the power switch and then disconnect all cables when relocating the product.
- Use two or more persons when relocating the product which weights more than 20 kg. The weight of the products can be found on the rear panel of the product and/or in this operation manual.
- Use extra precautions such as using more people when relocating into or out of present locations including inclines or steps. Also handle carefully when relocating tall products as they can fall over easily.
- Be sure the operation manual be included when the product is relocated.



Operation

- Check that the AC input voltage setting and the fuse rating are satisfied and that there is no abnormality on the surface of the AC power cord. Be sure to unplug the AC power cord or stop applying power before checking.
- If any abnormality or failure is detected in the products, stop using it immediately. Unplug the AC power cord or disconnect the AC power cord from the switchboard. Be careful not to allow the product to be used before it is completely repaired.
- For output wiring or load cables, use connection cables with larger current capacity.
- Do not disassemble or modify the product. If it must be modified, contact Kikusui distributor/agent.



Maintenance and checking

- To avoid electrical shock, be absolutely sure to unplug the AC power cord or stop applying power before performing maintenance or checking.
- Do not remove the cover when performing maintenance or checking.
- To maintain performance and safe operation of the product, it is recommended that periodic maintenance, checking, cleaning, and calibration be performed.



Service

- Internal service is to be done by Kikusui service engineers. If the product must be adjusted or repaired, contact Kikusui distributor/agent.

Sections of the operation manual

The contents of this operation manual are as follows:

Preface

Describes the outline, features, structure, and optional equipment of this controller.

Chapter 1 Unpacking and Installation

This chapter describes the necessary procedures, from unpacking the product to preparation before use.

Chapter 2 Basic Operation

This chapter describes the preparations to be made before turning on the power, and explains turning the power on and the operation of each function.

Chapter 3 Remote Control

This chapter provides the procedure for programming the remote control features of the instrument using an external device such as a personal computer.

Chapter 4 Part Names and Functions

This chapter provides the names and functions of the switches, indicators, connectors, and other parts of the front and rear panels.

Chapter 5 Maintenance and Calibration

This chapter describes the maintenance and calibration procedures for the instrument. To maintain the instrument's original performance for as long as possible, conduct periodic checks and maintenance.

Chapter 6 Specifications

This chapter provides the electrical and mechanical specifications of the instrument and its accessories.

Contents

Power Requirements of this Product	_____	I
⚠ Before using the Remote Control	_____	II
⚠ Safety Symbols	_____	III
⚠ Safety Precautions	_____	IV
Preface	_____	P-1
Product Outline	P-1	
Features	P-1	
Operation Manual and ROM Version	P-2	
Chapter 1 Unpacking and Installation	_____	1-1
1.1 Unpacking Checks	1-2	
1.2 Precautions for installation	1-4	
1.3 Precautions for moving	1-5	
1.4 Checking the Input Power and Fuse	1-6	
1.5 Connecting the AC Power Cord	1-8	
1.6 Grounding	1-9	
1.7 Checking Operations	1-10	
1.8 Load Wiring	1-11	
1.8.1 Precautions for Load Wiring	1-11	
1.8.2 Procedure for Connecting the Load	1-13	
Chapter 2 Basic Operation	_____	2-1
2.1 Display Indication When the Power is Turned On	2-2	
2.2 Basic Use of the Panel	2-3	
2.3 Constant Current, Constant-Resistance, Constant Power Modes, and the Crest Factor Function	2-4	
2.4 Basic Operation Procedures	2-12	
2.4.1 Operation in the CC Mode	2-12	
2.4.2 Operation in the CR Mode	2-14	
2.4.3 Operation in the CP Mode	2-17	
2.4.4 Operation of the CF Function	2-18	
2.4.5 Saving and Calling Up Setting	2-20	
2.4.6 Backup memory	2-24	
2.4.7 Alarms	2-25	

Chapter 3 Remote Control	3-1
3.1 Initial Setting	3-2
3.2 Programming Format	3-3
3.2.1 Program Messages	3-3
3.2.2 Response Message	3-4
3.2.3 Flow Control	3-4
3.3 Device Message	3-5
3.3.1 Program Header and Program (Response) Data	3-5
3.3.2 Configuration of Device Messages	3-6
3.4 Assignment of Register Bits	3-9
Chapter 4 Part Names and Functions	4-1
4.1 Front Panel	4-2
4.2 Rear Panel	4-6
Chapter 5 Maintenance and Calibration	5-1
5.1 Cleaning	5-2
5.1.1 Cleaning the Panel	5-2
5.1.2 Cleaning the Dust Filter	5-2
5.2 Inspection	5-3
5.3 Calibration	5-3
5.4 Requesting Repair	5-4
Chapter 6 Specifications	6-1
6.1 Electrical Specifications	6-2
6.2 Dimensional Diagram	6-4
6.3 Accessory	6-5
6.4 Options	6-6
Index	I-1

Preface

Product Outline

The PCZ1000 is an AC electronic load featuring high reliability and safety. This instrument provides improved operability through CPU control. In addition to the resistive loads generally used in tests, it is capable of simulating capacitor-input rectifier loads.

Features

■ Crest-factor function

In addition to the three modes - constant-current*, constant-resistance*, and constant-power* - the instrument has a crest-factor function, facilitating load tests using peak or harmonic currents. This helps reduce design and labor time and cost as well as improve the quality of the unit under test.

* The instrument always allows a current waveform close to a sine wave to flow unaffected by the voltage waveform.

■ Simple operation

The key features can be operated quickly on a one-key-to-one-feature basis. Fine adjustment is possible with the jog/shuttle rotary knob.

■ Easy-to-see LCD with backlight

The instrument features an LCD with LED backlight, enabling a variety of operations to be performed. This also makes indications of test information easily readable, as they are unaffected by ambient light.

Operation Manual and ROM Version

This manual applies to products equipped with any of ROM versions 1.00 to 1.09.

When contacting us with a question about one of our products, please provide us with the following information concerning the product:

- Type (PCZ1000)
- ROM version
- Manufacturing number (indicated on the product rear panel)

For information on how to confirm which ROM version you have, see Section 1.7, "Checking Operations".



- If you are not familiar with this type of AC Electronic Load, or are attempting to reinstall such a Load, be sure to first read the "Safety Precautions" and Chapter 1, "Unpacking and Installation" in order to ensure that you conduct all specified work correctly.
-

1

Chapter 1

Unpacking and Installation

This chapter describes the necessary procedures, from unpacking the product to preparation before use.

1.1 Unpacking Checks

Upon receiving the product, make sure the package contains the necessary accessories, and that the product has not been damaged during transportation. If any damage or imperfection is found, contact Kikusui distributor/agent.

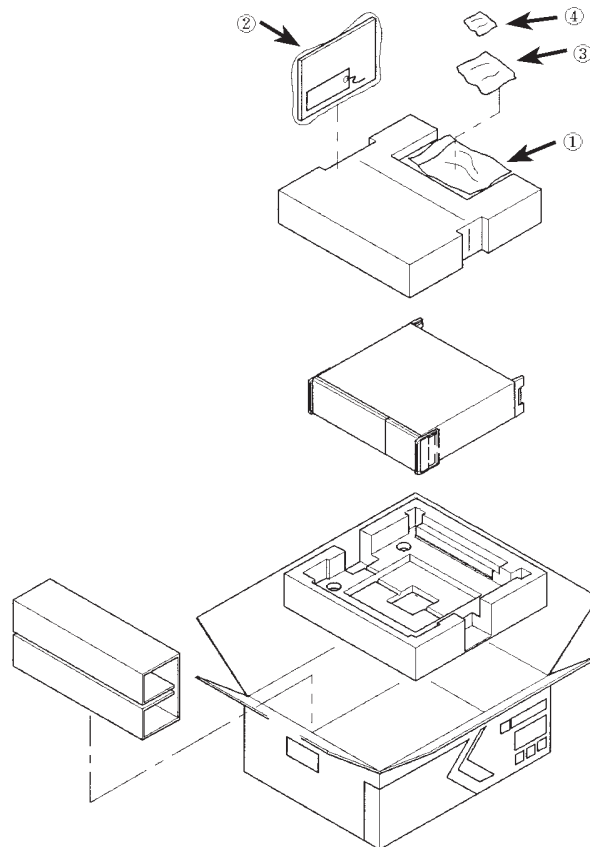
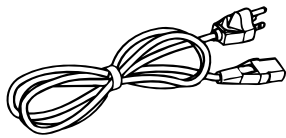

Fig. 1-1 Packing and Unpacking

NOTE

- Packing materials may be used for later transport of the product, so it is recommended that they be retained.



① AC Power cord
(1 cord)
[85-AA-0004]

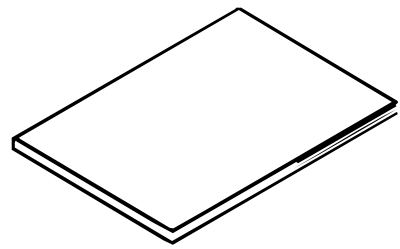

② Operation Manual (1 copy)
[Z1-001-902]

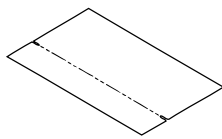

③ "Filter" Cleaning Sticker (1 sticker)
[A8-070-192]

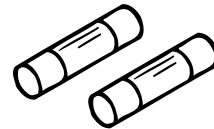

④ Fuses in different rating (2 fuses)

Fig. 1-2 Accessories

The table below lists fuse ratings. (Rated voltage: 250VAC)

Table1-1

Product for 100V power system		Product for 200V power system	
Inside the AC inlet 100V rating	Provided separately 200V rating	Inside the AC inlet 200V rating	Provided separately 100V rating
3A (S.B) 1 piece [99-02-0010]	2A (T) 2 pieces [99-00-0026]	2A (T) 1 piece [99-00-0026]	3A (S.B) 2 pieces [99-02-0010]

1.2 Precautions for installation

Be sure to observe the following precautions when installing the product.

■ Do not use the product in a flammable atmosphere.

To prevent explosion or fire, do not use the product near alcohol, thinner, or other combustible materials, or in an atmosphere containing such vapors.

■ Avoid locations where the product is exposed to high temperatures or direct sunlight.

Do not locate the product near a heater or in areas subject to drastic temperature changes.

Operating temperature range: 0°C to 40°C

Storage temperature range: -10°C to +50°C

■ Avoid humid environments.

Do not locate the product in a high-humidity environment—near a boiler, humidifier, or water supply.

Operating humidity range: 30% to 80% R.H (no dew condensation is allowed)

Storage humidity range: 20% to 90% R.H (no dew condensation is allowed)

Condensation may occur even within the operating humidity range. In that case, do not start using the product until the location is completely dry.

■ Do not place the product in a corrosive atmosphere.

Do not install the product in a corrosive atmosphere or one containing sulfuric acid mist or the like. This may cause corrosion of various conductors and imperfect contact with connectors, leading to malfunction and failure, or in the worst case, a fire.

■ Do not locate the product in a dusty environment.

Dirt and dust in the product may cause electrical shock or fire.

■ Do not use the product where ventilation is poor.

Prepare sufficient space around the product. Otherwise, heat may accumulate in the product, resulting in fire.

■ Do not place any object on the product.

Particularly a heavy one, as doing so could result in a malfunction.

■ Do not place the product on a tilted surface or in a location subject to vibrations.

If placed on a non-level surface or in a location subject to vibration, the product may fall, resulting in damage and injury.

■ **Do not use the product in locations affected by strong magnetic or electric fields.**

Operation in a location subject to magnetic or electric fields may cause the product to malfunction, resulting in electrical shock or fire.

1.3 Precautions for moving

When moving or transporting the product to an installation site, observe the following precautions.

■ **Turn off the POWER switch.**

Moving the product with the power on may result in electrical shock or damage.

■ **Remove all wirings connected.**

Moving the product with codes connected may break the codes or cause the product to fall, resulting in injury.

■ **For transportation, use the special packing material for the product.**

Transport the product in its original package to prevent vibration and falls, which may damage the product.

If you require packing material, contact Kikusui distributor/agent.

To use the handles, pull them from the instrument body as shown in the figure at right.

Simultaneously slide the two locks in each handle in the UNLOCK direction, and then pull the handles toward you until it clicks. The handle can now be used to carry the device.

To store the handles, simultaneously slide the two locks in the UNLOCK direction, and then push the handles forward. The handles are now locked.

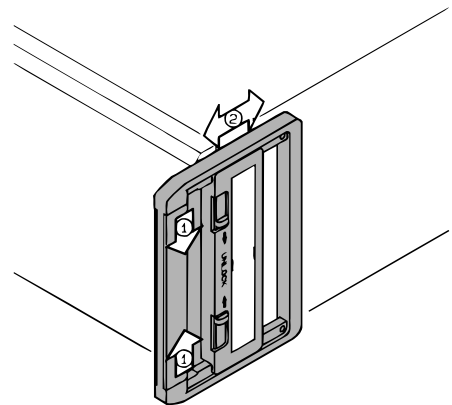

Fig. 1-3

1.4 Checking the Input Power and Fuse

This instrument is used by selecting one of the four input line voltage ranges specified in Fig. 1-4. Confirm that the factory-shipment setting is suitable for the AC line-input voltage to be used with the instrument. Also, ensure that the line fuse is properly rated for the AC line supply.

⚠ WARNING

• To avoid electric shock, always unplug the AC power code or turn off the power at the switchboard before checking or replacing the fuse.

⚠ CAUTION

• Select a fuse of the same style, rating, and characteristics as those provided with the instrument. The use of a fuse of incorrect rating or use of the instrument with a short-circuited fuse holder may damage the instrument.

To check (change) the voltage input range or check (replace) the line input fuse, follow the procedure specified below:

1. Turn OFF the POWER switch.
2. Disconnect the AC power code from the instrument.
3. Confirm that the settings of the line voltage range selector switches on the rear panel of the instrument match the line input voltage to be used to power the instrument.

To change the settings, follow the SWITCH POSITION instructions (see Fig. 1-4).

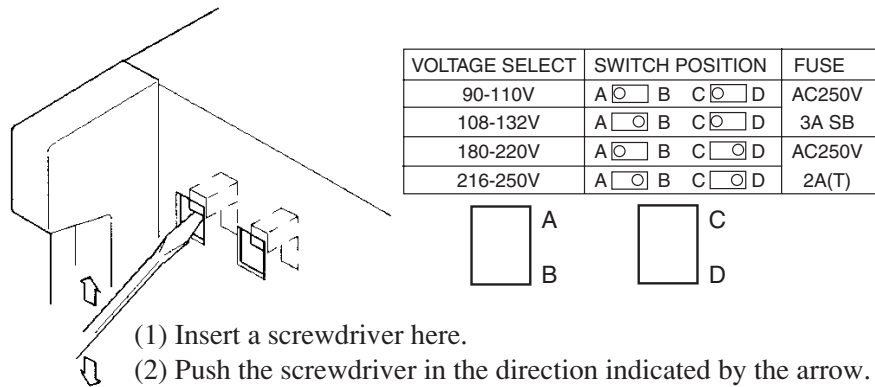

Fig. 1-4

-
4. Confirm that the rating of the installed fuse is appropriate for the line voltage to be used; also check that its time current characteristics are appropriate for the application.

Always replace with the correct fuse.

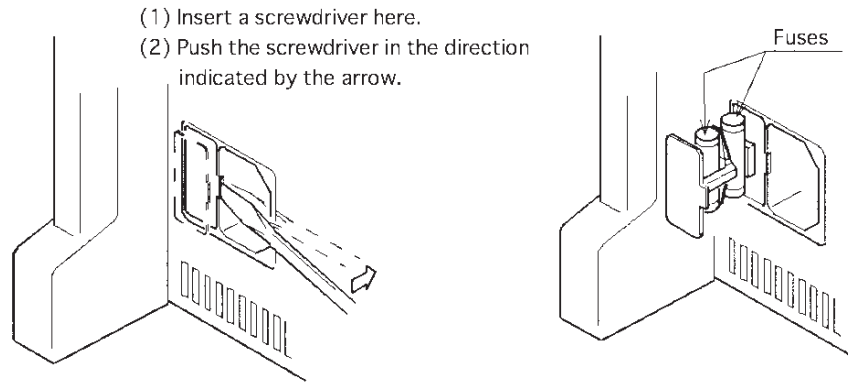

Fig. 1-5

1.5 Connecting the AC Power Cord

- ⚠ WARNING**
- If your product includes an AC power cord with a three-prong plug, check the line voltage range indicated on it. The rated voltage of this power cord is 125 VAC. To change the line voltage range to “180 V-220 V” or “211 V-250 V,” obtain a cord that is compatible with the power voltage to be used. The appropriate AC power code must be provided by the user.

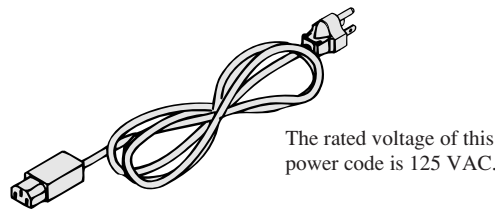

Fig.1-6 Accompanying power cord with a three-prong plug

Follow the procedure specified below to connect the AC power code:

1. Turn OFF the POWER switch.
2. Connect the supplied AC power code to the AC INPUT connector on the rear panel.
3. Insert the plug of the AC power code into an AC line receptacle.

■ Direct connection to a switchboard

To directly connect the instrument to a switchboard without using the power plug, remove the plug from the AC power code and attach crimp terminals to the conductors.

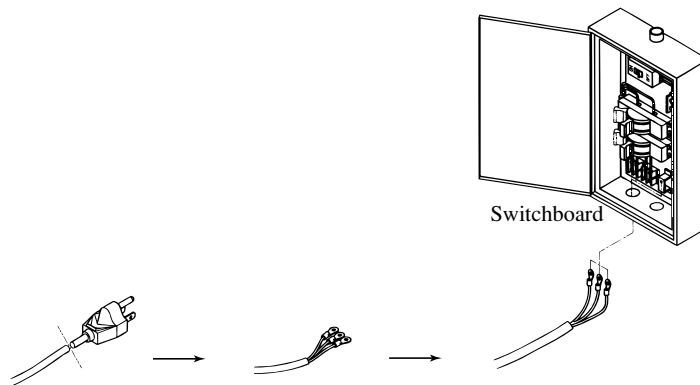

Fig. 1-7

- ⚠ WARNING**
- Because the rated voltage of the AC power code with a three-prong plug shown in Fig. 1-6 is 125 VAC, even when the plug is removed and crimp terminals are attached, it cannot be used.
 - To avoid electric shock, turn OFF the switch at the switch panel before making connections to it.
 - Only qualified personnel should make connections to the switch panel.

1.6 Grounding

⚠ WARNING

- Not grounding the instrument creates danger of electric shock.
- Connect the ground terminal to an electrical ground (safety ground).

⚠ CAUTION

- Not performing adequate grounding work on the instrument results in malfunction or the production of large noises from the instrument.

To ensure safety, provide secure grounding.

The two methods specified below can be used to ground the instrument. Either one will ground the instrument securely.

1. Connect the terminal marked with the ground symbol (⊕) on the rear panel of the instrument to a dedicated ground (GND) terminal.
2. Plug the power code into a three-contact electrical outlet in which proper grounding is provided.

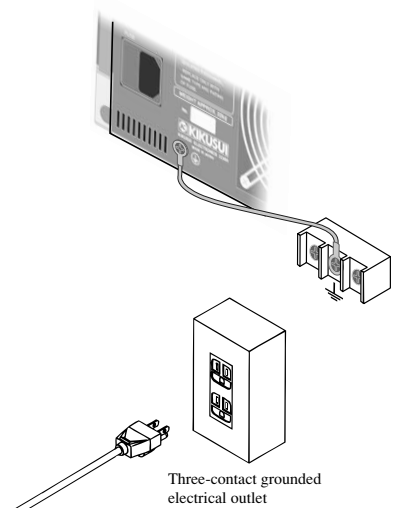

Fig.1-8

1.7 Checking Operations

Check the operation of the instrument in accordance with the following procedure:

1. Confirm that the instrument's POWER switch is off.
2. Confirm that the instrument's AC power code is properly connected to an electrical outlet.
3. Turn on the instrument's POWER switch.
4. Check the indications on the display (see the examples below).

Example of indication of normal condition:

PCZ1000 Ver 1.00

The lower part indicates the ROM version.

(Indication approximately two seconds later)

0.00Ar 0.0Ap 0.0V -- ISET 0.00A --

Example of indication of abnormal condition:

If the display unit is in any of the states specified below, the instrument should be considered defective. If the condition persists after the steps specified below are taken, contact Kikusui distributor/agent.

The backlight does not light and there is no indication:

(No indication)

Make sure the AC power code is connected properly, and turn the POWER switch on again.

The display indicates an abnormal current or voltage value:

13.54Ar 5.3Ap 71.4V -- ISET 0.00A --

Turn the POWER switch on again.

5. Press the [I SET] key to light up the lamp above it. The instrument will enter a condition in which settings can be entered in the constant-current (CC) mode.
6. Press the [LOAD] key to confirm that the lamp above it lights up.
7. Press the [LOAD] key again to confirm that its lamp goes off.
8. Turn the POWER switch off to complete the operation check.

1.8 Load Wiring

The instrument must be properly wired to ensure that its functions operate accurately and consistently.

1.8.1 Precautions for Load Wiring

● Wires to be used for wiring

If the resistance of the wires used for the load wiring is too large, the voltage applied to the load terminals may be less than the minimum operation start voltage of 3 V_{peak} required by the instrument when a current is supplied. Always use the thickest wire possible.

-
- ⚠ CAUTION** • Use load wires that are sufficiently thick for current to flow and that have a noncombustible or flame-resistant insulation.
-

The size of the instrument's load terminal connection screws is M4.

● Inductance of load input

If the load wiring is too long or a large loop is formed in the wiring, the inductance of the load input increases, resulting in a phase delay in the current. This may result in unstable instrument control or oscillation. If the unit to be connected is inductive, the phase will also be shifted, which may result in oscillation. This is not a problem with capacitive devices. To prevent problems of this kind, the load wiring should be as short as possible, and should be twisted or laid as shown in Fig. 1-9. If oscillation still occurs even when the wires are dressed in this way, install a capacitor of 0.1 to 0.47 μF across the load terminals L and N of the instrument. In this case, note that a slight distortion is introduced to the current waveform (near the Zero current turn-on point).

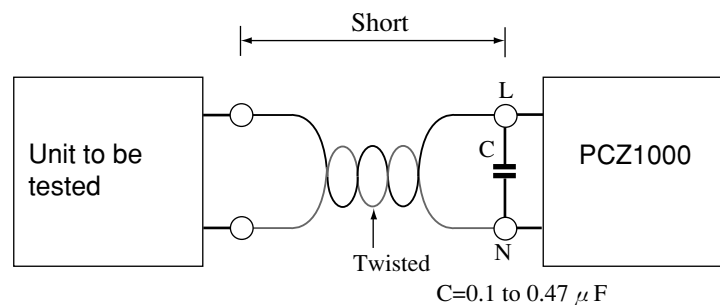

Fig. 1-9

● Overvoltage

The maximum voltage that can be applied to the load terminals of the instrument is 400 V_{peak}. Application of a voltage exceeding this level will damage the instrument.

- In particular, when testing a power supply with a large inductance, such as an autotransformer, also beware of voltage spikes generated by sudden current changes. If test conditions of this kind are anticipated, a protective element, such as surge absorbers, is recommended across the load terminals of the instrument before testing commences.

-
- ⚠ CAUTION** • Do not apply a voltage exceeding the maximum voltage of 400 V_{peak}. If a voltage exceeding this level is applied, the instrument will display and sound an alarm and enter the load-off state. In such a case, immediately lower the voltage of the unit being tested.
-

● Other precautions

-
- ⚠ CAUTION** • The L and N load terminals are connected internally through 0.01 μ F capacitors to the G terminal (case) instrument to filter noise emitted by the unit under test. Thus, if one end of the output terminals of the unit under test (UUT) is grounded, a small leakage current (approximately 1 mA max.) will flow from the output terminals to the instrument case (ground).
-

1.8.2 Procedure for Connecting the Load

-
- ⚠ WARNING** • Do not touch the load terminals while power is supplied, as the output voltage of the unit under test is applied to the load terminals. Electric shock may result.
-

1. Turn off the POWER switch of the instrument.
 2. Make sure that the output voltage of the unit under test does not exceed the maximum input voltage of the instrument.
-

- ⚠ CAUTION** • The maximum load input voltage of the instrument is 400 V_{peak}.
-

3. Confirm that the present output voltage of the unit under test is 0 V.
 4. Remove the load terminal cover (see Fig. 1-10).
 5. Attach crimp terminals to the appropriate wires of the UUT, then connect them to the instrument load terminals.
 6. Replace the load terminal cover on the instrument.
-

- ⚠ CAUTION** • Always use the load terminal cover at the load terminals, attach crimp terminals to the wires, and connect them using the screws provided at the terminals.
-

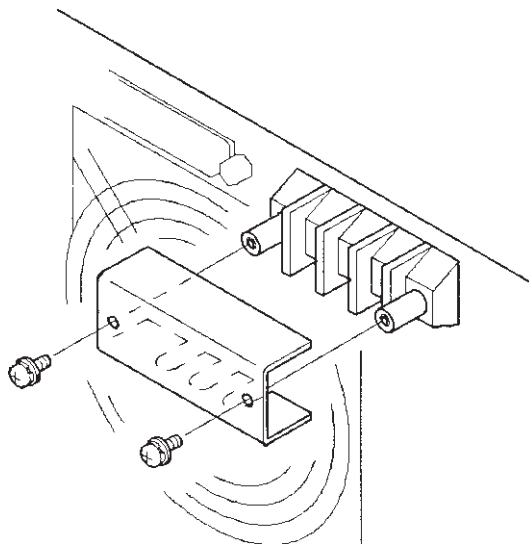

Fig. 1-10



2

Chapter 2 Basic Operation

This chapter describes the preparations to be made before turning on the power, and explains turning the power on and the operation of each function.

2.1 Display Indication When the Power is Turned On

When the POWER switch on the front panel is pressed to turn on the power, the display unit shows the following:

```
PCZ1000
Ver. 1.00
```

In this initial-indication example of the display, the upper part shows the model number of the instrument, and the lower part shows the ROM version. Approximately two seconds later, the display changes to that shown below.

▼ Approximately two seconds later:

```
0.00Ar 0.0Ap 0.0V
-- ISET 0.00A --
```

The upper part indicates the rms current (A_r), peak current (A_p), and rms voltage (V) supplied to the load terminals of the instrument. The lower part shows the operation mode (the indicated example is "I SET", or the condition in which the constant-current mode is enabled) and the setting (in the example shown: 0.00 A).

2.2 Basic Use of the Panel

This section describes the basic operating procedures for the front-panel keys.

Selection of functions

The basic functions of the instrument are selected by pressing the key assigned to each function. To exit the currently selected function, press the [ESC] key.

Operation of the [SHIFT] key

To use a function indicated in blue characters directly below a key, press the [SHIFT] key. Follow the procedure specified below to operate the [SHIFT] key:

Press the [SHIFT] key first, Next press the desired function key. When the [SHIFT] key is pressed, the LEDs (green) above the keys light up to show that the functions indicated in blue characters are selectable.

In this manual, operation of the [SHIFT] key is expressed as shown below.

Example of operation for switching the range in the CR mode:

[SHIFT] + [R SET] (RANGE)

Alarm indicating incorrect keying

If an invalid key is pressed during key operation, a buzzer will sound.

2.3 Constant Current, Constant-Resistance, Constant Power Modes, and the Crest Factor Function

Basic operation method for the instrument

■ Differences in operations between direct-current and alternating-current loads

In general, a constant current load always maintains current flow at a constant level, regardless of the applied voltage. Direct current loads operate in this way in the constant-current mode.

For alternating-current loads, if the AC load operates in the way mentioned above, the current waveform becomes square (rectangular) regardless of the waveform of the applied voltage, which differs from a realistic alternating-current load in that the polarity is inverted with the current kept constant. This instrument controls the rms value of the current to ensure that the load current always has a sine waveform (except for the crest factor function). That is, when the voltage is constant and the waveform is sinusoidal, the instrument is always seen as a purely resistive load.

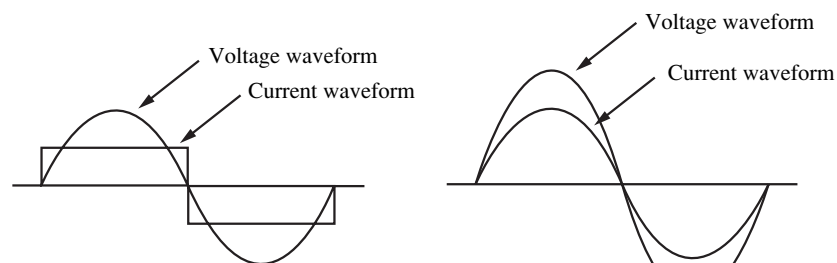

Operation of a true constant current

Fig. 2-1

Operation of PCZ1000

Crest factor function

The instrument varies the crest factor (CF = peak/rms; see the definition below) by changing the angular width (using the 90° and 270° peak values) of the current waveform. In this case, the current waveform is similar to a capacitor-input full-wave rectified waveform. (In a strict sense, however, it contains different harmonic components.)

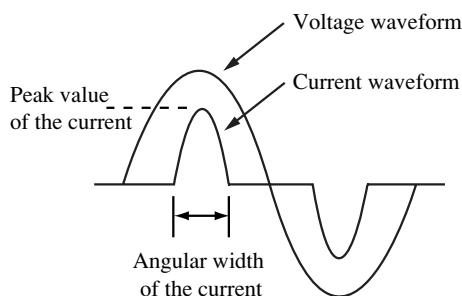

Fig. 2-2

DESCRIPTION Definition of basic alternating current terms

- Root-mean-square value, X(rms)

Square root of the average of the square of the instantaneous value (value X (t) at time "t") of the alternating-current waveform (voltage or current)

$$X = \sqrt{\frac{1}{T} \int_0^T (X(t))^2 dt} \quad \text{Where T is one cycle of alternating current}$$

- Apparent power, VA

Product of the root-mean-square value of the voltage, Vrms, and current, Irms

$$VA = V_{rms} \times I_{rms}$$

- (Active) power, P (W)

Mean value of the product (instantaneous power p (t)) of the instantaneous value of the voltage (v) and that of the current (i)

$$P = \frac{1}{T} \int_0^T P(t) dt$$

- Crest factor (CF)

Ratio of the peak (crest) value of the voltage or current to its rms value

$$CF = X_{peak}/X_{rms}$$

CAUTION

- Because the instrument controls the amplitude of sinusoidal current by detecting the rms value of an input voltage waveform, if the input voltage changes suddenly, the current value will momentarily become unstable (response rate: approximately 1 s).
- If the frequency of the input voltage changes suddenly, the waveform of the power is distorted for a few cycles. (See Fig. 2-3. The smaller the change in frequency, the less distortion is generated.)
- Input of DC voltage or voltage out of the rated frequency range results in improper operation. (If the input voltage is over the rated frequency range, the instrument will maintain the waveform until complete synchronization <1> in Fig. 2-3. If the input voltage is below the rated frequency range, it will maintain the waveform until complete synchronization <2> in Fig. 2-3. In the case of DC voltage, no current flows.)
- A virtually sinusoidal current flows regardless of the input voltage waveform.

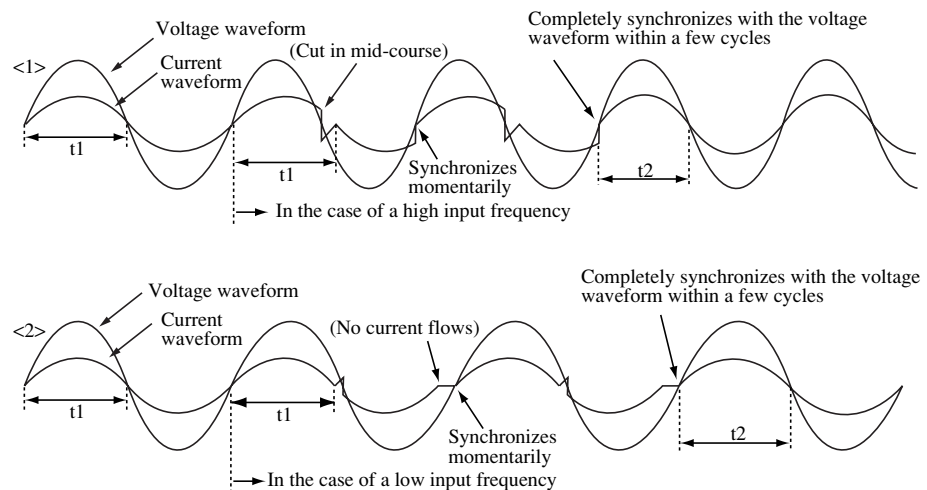

Fig. 2-3

The basic operations in each operation mode are described below. The instrument offers the following three types of operation modes and one function:

- Constant-current mode (CC mode)
- Constant-resistance mode (CR mode)
- Constant-power mode (CP mode)
- CREST FACTOR function (CF function)

■ Basic operations in the CC mode

Setting a current value allows the instrument to maintain the rms value of the input current at a constant level in accordance with the set current value, regardless of the input voltage of the instrument (in an operation range to be described later).

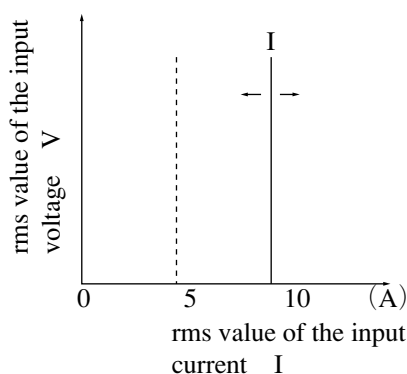

Fig. 2-4

■ Basic operations in the CR mode

Setting a resistance value enables the instrument to sink the rms value of the input current in proportion to the rms input voltage of the instrument, according to the set resistance value (in an operation range to be described later). That is, the instrument maintains the "input voltage (rms value) / input current (rms value) = resistance value" constant.

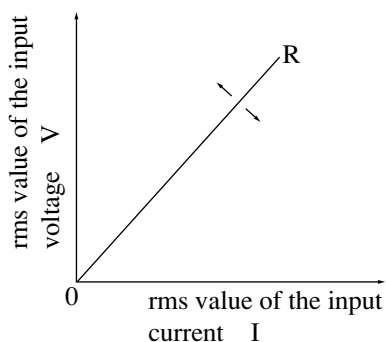

Fig. 2-5

■ Basic operations in the CP mode

Setting a power value enables the instrument to sink the rms value of input current in inverse proportion to the rms input voltage of the instrument, according to the set power value (in an operation range to be described later). That is, the instrument keeps the "input voltage (rms value) x input current (rms value) = apparent power value" constant.

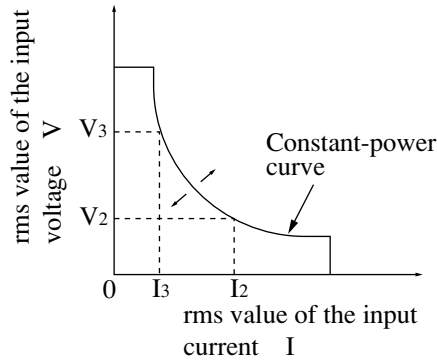

Fig. 2-6

■ Operations of the CF function

Setting a CREST FACTOR value enables the instrument to vary the angular current width of the input current waveform of the instrument (while current is flowing), in accordance with the set CREST FACTOR value. That is, the instrument keeps the "peak value of the input current / rms value = CREST FACTOR value" constant. Moreover, the rms value of the current flow is maintained at the current value set in the CC mode.

- The peak of the input current is almost at the 90° and 270° points of the phase angle of input voltage. (If the input voltage is distorted, the peak of the input current will not necessarily agree with the peak position of the input voltage.)
- The current waveform within the angular width of the current is sinusoidal (this differs slightly from that of a capacitor-input rectifier circuit).
- This function is only available in the CC mode.

■ Operation range of the instrument

Operation range of this instrument is limited by the rated current, rated voltage, and rated power; the instrument can only be operated within the range indicated by the shaded area in the figure below. Note that if the input voltage is less than 20 V_{peak} (approximately 14 V_{rms}), the instrument cannot sink the rated current and thus does not meet the specifications of the various characteristics. Moreover, it also cannot synchronize with the input-voltage frequency, which may cause an extremely large distortion in the current waveform. With a low input voltage, the current waveform distortion becomes large. This distortion also becomes large for light loads for which the input voltage is high and the input current is low.

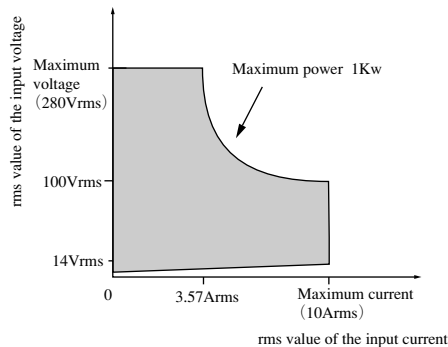
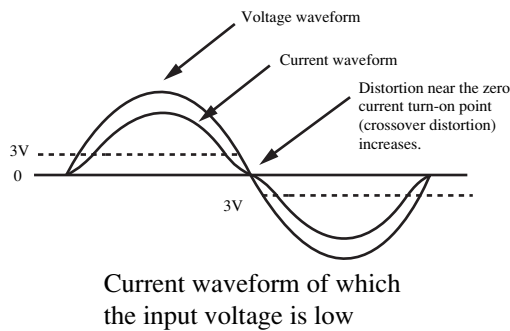

Fig. 2-7

■ Operating point of the instrument

The operating point of the instrument varies depending on the operation mode and the settings for that mode. The operating point also depends on the voltage and current conditions of the unit under test (UUT). The following describes the transition (mode transition) state of the instrument operating point when the input voltage or input current is changed in the basic CC and CR modes.

◎ Transition of the operating point in the CC mode

In the figure at the below, line A-B is the transition of the operating point in the CC mode, and line B-C is that of the operating point in the CP mode. When the rms value of the input voltage (V_1) is increased, the instrument operates in the CC mode starting at point A, and changes to operation in the CP mode when the operating point shifts to point B. When V_1 is further increased, the current value decreases (see the previous "Basic operations in the CC mode"). For line 0-A, the internal instrument senses as if it were operating in the CC mode.

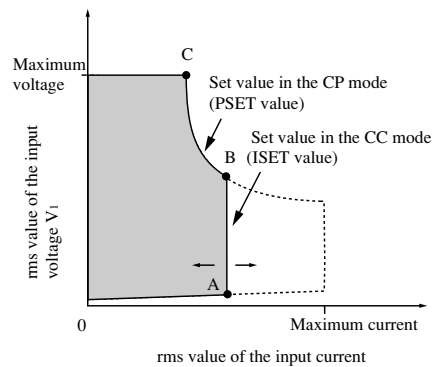

Fig. 2-8

◎ Transition of the operating point in the CR mode

In the figure at below, line F-G is the transition of the operating point in the CR mode, line G-H is that of the operating point in the CC mode, and line H-I is that of the operating point in the CP mode. When the rms value of the input voltage (V_1) is increased, the instrument operates in the CR mode starting at point F, and changes to operation in the CC mode when the operating point reaches point G. When it moves further and reaches point H, the instrument changes to operation in the CP mode (see the previous "Basic operations in the CR mode"). Note that the instrument may change directly from an operating point in the CR mode to that in the CP mode, depending on the PSET and RSET values.

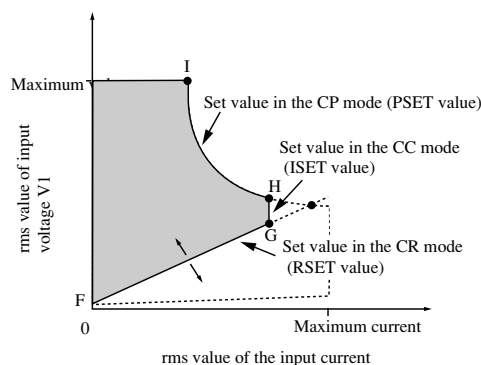

Fig. 2-9

◎ Display of the operation mode and function

The currently selected operation mode and function are indicated by LEDs on the operation panel.

CC mode: The CC lamp (red) above the [I SET] key lights.

CR mode: The CR lamp (yellow) above the [R SET] key lights.

CP mode: Both the CC lamp (red) and CR lamp (yellow) light.

CF function: The CF lamp (green) above the [C.F] key lights. Because the CREST FACTOR function is valid only in the CC mode, the CC lamp (red) also lights.

If the instrument is restricted by the operation range of any mode other than the selected operation mode, the relevant lamp blinks.

Blinking of the CC lamp: The instrument is in the CP operation range when the CC mode is selected.

Blinking of the CR lamp: The instrument is in the CC or CP operation range when the CP mode is selected.

Blinking of both the CC and CP lamps:
The instrument is in the CC operation range when the CP mode is selected.

NOTE

- In the CP mode, if the input voltage is low, the instrument may not reach the CP operation range and may enter the CC operation range. This causes both the CC and CR lamps to blink. For example, when 1000 W is set as the RSET value and 10 A is set as the ISET value, the instrument will not enter the CP operation range unless the input voltage is 100 Vrms or more. In the same way, when the PSET value is 140 W, it does not enter the CP operation range unless the input voltage is 14 Vrms or more.

In the range in which the input voltage is 10 V rms or less, the instrument is unable to sink its maximum current (10 Arms; see the previous "Operation range of the instrument"). Thus, even when a current of the ISET value or less flows, the instrument apparently operates in the CC operation range, causing both the CC and CR lamps to blink.

In particular, near an input voltage of 0 Vrms, the CC operation current becomes almost 0 Arms. This causes both the CC and CR lamps to blink, even when no power supply under test is connected to the instrument.

2.4 Basic Operation Procedures

This section describes the basic operation procedures using front panel display examples.

Each operation procedure is described on the assumption that the instrument has already been initialized. To initialize the instrument, turn on the POWER switch with the [MEM] key held down.

For the initial values, see 2.4.6, Backup Memory.

In the following, for the set values of the operation modes, a CC mode current set value is expressed as a "ISET value," a CR mode resistance set value is expressed as a "RSET value," a CP mode power set value is expressed as a "PSET value," and a CF-function CREST FACTOR set value is expressed as a "CREST FACTOR value."

2.4.1 Operation in the CC Mode

● Preliminary setting

Press the [P SET] key to display "PSET" on the display unit, and use the jog/shuttle rotary knob to set a PSET value. The setting should be such that power greater than the maximum power to be tested, or an excessively high power, is not drawn from the unit under test. When the instrument is initialized as described above, the PSET value is automatically set to the maximum power value of the instrument. If it is not necessary to change this value, this preliminary setting is not required.

● Setting an ISET value and turning a load on and off

As an example, the following describes the operations for setting the ISET value to 5.00 A in the CC mode, and turning the load (current) on and off:

1. If the load is currently on (the green LED above the [LOAD] key is lit), press the [LOAD] key to turn it off (the green LED goes off).
2. Press the [I SET] key to light up the CC lamp (red LED) above the key. This enables the CC mode. "ISET" is shown in the lower part of the display, allowing an ISET value to be set (the value at the lower part indicates the present setting).

0.00Ar	0.0Ap	100.1V
-- ISET	0.00A	--

NOTE

- In load-on state, the operation mode cannot be switched.
-

-
3. The shuttle knob is the rough adjustment; use it to set an approximate ISET value. Turn this knob clockwise to increase the value; turn it counterclockwise to decrease it. The rate of increase or decrease depends on the degree by which the knob is turned.

```
0.00Ar 0.0Ap 100.1V
-- ISET 4.50A --
```

4. The jog knob is the fine adjustment; use it to set the value precisely. Turn the knob clockwise to increase the value; turn it counterclockwise to decrease it. This completes the setting of the ISET value (in this example, it was set to 5.00 A).

```
0.00Ar 0.0Ap 100.1V
-- ISET 5.00A --
```

Next, the load on/off procedure will be described.

5. Press the [LOAD] key to light the green LED above the key. This causes the instrument to sink current, taking it into the load-on state. The upper part of the display shows the present rms value of the current, the peak value of the current, and the rms value of the voltage.

```
5.00Ar 7.1Ap 100.0V
-- ISET 5.00A --
```

6. To turn the load off, press the [LOAD] key again. This causes the lamp above the key to go off, returning the display to the previous state.

NOTE

- If the ISET value is set to approximately 0 A, an offset current of several 10 mA may flow; the setting accuracy of the instrument is $\pm(1\% + 0.1 \text{ A})$. Moreover, this offset current may decrease the actual setting resolution at an ISET value of approximately 0 A.
(The setting resolution is the minimum variable width that can be set.)
-

2.4.2 Operation in the CR Mode

● Preliminary setting

Press the [P SET] key to show "PSET" on the display unit, and use the jog/shuttle rotary knob to set a PSET value. The setting should be such that power greater than the maximum power to be tested, or an excessively large power, is not drawn from the unit under test. Next, press the [I SET] key to display "ISET" on the display unit, and use the jog/shuttle knob to set an ISET value. The setting should be such that a current greater than the maximum current to be tested, or an excessively large current, is not drawn from the unit under test. When the instrument is initialized, the PSET value is automatically set to the maximum power value of the instrument. If it is not necessary to change this value, this preliminary setting is not required. Set the RSET value to the largest anticipated current.

● Setting an RSET value, turning the load on and off, and switching the range

As an example, the following describes the operations necessary to set the RSET value to 10.000Ω in the CR mode, turn to the load (current) on or off, and to switch the range:

1. If the load is currently on (the green LED above the [LOAD] key is on), press the [LOAD] key to turn it off (the green LED goes off). Set the ISET value to 10.5 A.

```
0.00Ar 0.0Ap 85.0V
-- ISET 10.50A --
```

2. Press the [R SET] key to light the CR lamp (yellow LED) above the key. This enables the CR mode.

The lower part of the display shows "RSET," allowing an RSET value to be set (the value in the lower part shows the present set value). "H" indicates that the H range is selected.

```
0.00Ar 0.0Ap 85.0V
-- RSET 1000.0Ω H--
```

NOTE

- In the load-on state, the operation mode cannot be switched.

3. The shuttle knob is the rough adjustment; use it to set an approximate RSET value. The value increases when the knob is turned clockwise, and decreases when it is turned counterclockwise. The rate of increase or decrease depends on the degree by which the knob is turned.

```
0.00Ar 0.0Ap 85.0V
-- RSET 11.905Ω H--
```

4. The jog knob is the fine adjustment; use it to set the value precisely. The value increases when the knob is turned clockwise, and decreases when it is turned counterclockwise. This completes the setting of the RSET value (in this example, it was set to 10.000 Ω).

```
0.00Ar 0.0Ap 85.0V
-- RSET 10.000  $\Omega$  H--
```

Next, the load on/off procedure is described.

5. Press the [LOAD] key to light the lamp (green LED) above the key. This causes the instrument to sink current and go into the load-on state. The upper part of the display shows the present rms value of the current, the peak value of the current, and the rms value of the voltage.

```
8.49Ar 12.0Ap 84.9V
-- RSET 10.000  $\Omega$  H--
```

6. To turn the load off, press the [LOAD] key again. This causes the lamp above the key to go off, returning the display to its previous state.

```
0.00Ar 0.0Ap 85.0V
-- RSET 10.000  $\Omega$  H--
```

Next, the range-switching procedure is described.

7. Press the [LOAD] key to go into the load-on state, then use the jog/shuttle rotary knob to set an RSET value. Changing the RSET value in the load-on state simultaneously changes the value of current the instrument sinks. In this example, the RSET value was changed to 8.9285 Ω , so the value of current indicated at the upper left part of the display has also changed to 9.51 A (the present range H is indicated in the lower part).

```
9.51Ar 13.5Ap 84.9V
-- RSET 8.9285  $\Omega$  H--
```

8. Press the [SHIFT] + [R SET] (RANGE) keys to switch the range. In this example, because the range is switched to L, the resistance is limited to the minimum value of the L range (9.0000 Ω in this example), and the current decreases. It is not possible to set an RSET value below the minimum value. If the RSET value is within the actual setting range (9.0000 Ω to 1000.0 Ω) in which the H and L ranges overlap each other, the RSET value does not change even if the range is switched. Note that because the setting resolution differs depends on the range, the RSET value will be set to a higher resistance value in the setting resolution of the range selected after switching.

```
9.43Ar 13.3Ap 84.9V
-- RSET 9.0000  $\Omega$  L--
```

-
9. To return the range to "H," press the [SHIFT] + [R SET] (RANGE) keys. The RSET value will change to a value (9.0090 Ω) that is close to the setting of the previous range L (9.0000 Ω), and is a higher resistance value in the setting resolution of the H range.

9.42Ar	13.3Ap	84.9V
-- RSET	9.0090 Ω	H--

DESCRIPTION

- Setting range of the H range: 1 Ω to 1 k Ω

Setting range of the L range: 10 Ω to 10 k Ω

The specification setting ranges of the H and L ranges are as shown above. In reality, however, the L range can be set from 9.0000 Ω to 10.000 k Ω .

Thus, in the example in step 8, the minimum value applied when the range is switched to range L is 9.0000 Ω , and the setting range overlapping the H and L ranges is from 9.0000 Ω to 1000.0 Ω .

NOTE

- The setting resolution and operation range in the L range are 1/10 of those in the H range.
 - Among the RSET values, the unit of setting resolution is in siemens (S). Thus, the desired resistance value may not be achieved. In such a case, a higher resistance value in the setting resolution applies. For example, if the instrument is remotely controlled in the H range, entering 251 Ω (3.98 mS) as the RSET value sets the RSET value to 333.33 Ω (3 mS).
 - If the RSET value is set such that the current the instrument sinks becomes approximately 0 A (for example, RSET of 10 k Ω at an input of 10 V), an offset current of several tens of milliamps may flow (the setting accuracy of the instrument is $\pm(2\% + 0.2 \text{ A})$ in of current). Moreover, this offset current may decrease the actual setting resolution at approximately 0 A (the setting resolution is the minimum variable width that can be set).
-

2.4.3 Operation in the CP Mode

● Preliminary setting

Press the [I SET] key to display "ISET" on the display unit, and use the jog/shuttle rotary knobs to set an ISET value. The setting should be such that a current greater than the maximum current, or an excessively large current, is not drawn from the unit under test.

● Setting a PSET value and turning the load on

As an example, the following describes the operations necessary to set the PSET value to 800 W in the CP mode, and to turn load (current) on:

1. If the load is currently on (the green LED above the [LOAD] key is on), press the [LOAD] key to turn it off (the green LED goes off).

```
0.00Ar 0.0Ap 179.6V
-- ISET 10.50A --
```

2. Press the [P SET] key to light the CC lamp (red LED) and CR lamp (yellow LED). This enables the CP mode. The lower part of the display shows "PSET," allowing a PSET value to be set (the value at the lower part indicates the present setting).

```
0.00Ar 0.0Ap 179.6V
-- PSET 1050W --
```

NOTE

- In load-on state, the operation mode cannot be switched.
-

3. Use the jog/shuttle rotary knobs to set a PSET value (in this example, it is set to 800 W).

```
0.00Ar 0.0Ap 179.6V
-- PSET 800W --
```

4. Press the [LOAD] key to light the lamp (green LED) above the key. This causes the instrument to sink current, taking it into the load-on state. The upper part of the display shows the present rms value of the current, the peak value of the current, and the rms value of the voltage.

```
4.46Ar 6.3Ap 179.4V
-- PSET 800W --
```

2.4.4 Operation of the CF Function

The CF function simulates the current waveform of a capacitor-input rectifier load.

● Preliminary setting

Press the [P SET] key to show "PSET" on the display unit, and use the jog/shuttle rotary knobs to set a PSET value. The setting should be such that power greater than the maximum test power, or an excessively large power, is not drawn from the unit under test. For the ISET value, set the value of the rms current to be supplied from the unit under test (in the example below, it is 7 A).

● Setting a CREST FACTOR value and turning the load on

As an example, the following describes the operations necessary to set the CREST FACTOR value to 2.0 in the CF function, and to turn the load (current) on:

1. If the load is currently on (the green LED above the [LOAD] key is lit), press the [LOAD] key to turn it off (the green LED goes off).
2. Press the [I SET] key to light the CC lamp (red LED) above the key. This enables the CP mode.
3. Press the [SHIFT] + [C.F] keys to light the lamp (green LED) above the key. This enables the CF function.

```
0.00Ar 0.0Ap 95.1V
-- ISET      7.00A  --
```

4. Press the [C.F] key again to display "CREST FACTOR" in the lower part of the display. This allows a CREST FACTOR value to be set (the present setting is displayed at the lower part).

```
0.00Ar 0.0Ap 95.1V
--CREST FACTOR 1.4--
```

5. Use the jog/shuttle knobs to set the CREST FACTOR value. This completes the setting of the CREST FACTOR value (in this example, it was set to 2.0).

```
0.00Ar 0.0Ap 95.1V
--CREST FACTOR 2.0--
```

Next, the load on/off procedure is described.

6. Press the [LOAD] key to light the lamp (green LED) above the key. This causes the instrument to sink current, taking it into the load-on state. The lower left part of the display shows "CREST FACTOR," indicating that the instrument operates using the CREST FACTOR function. The upper part also shows the present rms value of the current, the peak value of the current, and the rms value of the voltage.

```
7.00Ar14.0Ap 95.0V
--CREST FACTOR 2.0--
```

In this condition, pressing the [I SET] key to change the I SET value allows the to vary rms current drawn from the unit under test to be varied, with the CREST FACTOR value kept constant (at 2.0 in this case). Further, pressing the [C.F] key enables the CREST FACTOR value to be changed.

```
8.00Ar11.3Ap 95.0V
-- ISET      8.00A  --
```

7. To exit the CF function, press the [SHIFT] + [C.F] keys again.

NOTE

- Note that even when the CREST FACTOR value is varied, the ISET value does not change. That is, only the peak value of the current may be changed at a constant rms current.
 - The CF function is only available in the CC mode.
-

2.4.5 Saving and Calling Up Setting

Memories A, B, and C are provided for the following modes and functions, enabling the settings specified below to be saved and/or called up.

CC mode: ISET value and CF function (CREST FACTOR value)

CR mode: RSET value and range setting

CP mode: PSET value

(a) Saving in memory and modifying memory contents

To save settings and ranges in memory, use the [MEM] key. To modify saved values and ranges, press the [SHIFT] + [MEM] (DMEM) keys. Saving to memory is possible in either the load-on or load-off state. In the example shown below, saving is done in the load-on state.

● Saving procedure using the [MEM] key

The procedure below saves the present setting and range indicated on the display.

1. Press the [I SET], [R SET], [P SET], or [SHIFT] + [C.F] keys to select the operation mode or function of the setting to be saved.

You can now assume that the RSET value and range setting are displayed in the CR mode.

```
7.64Ar10.8Ap 84.9V
-- RSET 11.111Ω H--
```

2. To modify and save the present value, change the RSET value using the jog/shuttle rotary knobs, and change the range by pressing the [SHIFT] + [RSET] (RANGE) keys.

In this example, the RSET value is modified to 10.000Ω, and then saved with range H unchanged.

```
8.49Ar12.0Ap 84.9V
-- RSET 10.000Ω H--
```

3. Press the [MEM] key. The lower part of the display shows "MEM<ABC>Save Mode."

```
8.49Ar12.0Ap 84.9V
-- MEM<ABC>Save Mode
```

-
4. Use the [A], [B], or [C] key to specify the target memory. This simultaneously saves the RSET value and range to the specified memory.

In this example, the [A] key is pressed to specify memory A; the lower right of the display indicates "A." To save the same setting in another memory, press the [B] or [C] key in this condition. This changes the "A" indication to "B" or "C," and saves the settings to the specified memory.

```
8.49Ar12.0Ap 84.9V
-- MEM<ABC>Save A --
```

5. If the [MEM] or [ESC] key is pressed, the display returns to the state before the save operation was done. To save another setting, repeat the procedure starting from step 1 or 2.

```
8.49Ar12.0Ap 84.9V
-- RSET 10.000Ω H--
```

NOTE

- To save the CREST FACTOR value to memory, set a CREST FACTOR value, press the [I SET] key to enter the CC mode, and press the [MEM] key, then press the [A], [B], or [C] key. This saves the I SET value and CREST FACTOR value together as a set to the selected memory.
-

● Modifying and saving procedure using the [SHIFT] + [MEM] (DMEM) keys

The procedure below modifies and saves the contents stored in memory of the same operation mode, regardless of the present setting and range.

1. The description is based on the assumption that the [I SET], [R SET], [P SET], or [SHIFT] + [C.F] keys were used to select the operation mode, and that the instrument is in load-on state.

It is now safe to assume that the RSET value and range setting are displayed in the CR mode.

```
7.64Ar10.8Ap 84.9V
-- RSET 11.111Ω H--
```

2. Press the [SHIFT] + [MEM] (DMEM) keys to show "Rval" in the lower part of the display (letter A in <> in the following indication specifies the particular memory in which the setting and range were saved).

In this example, "10.000Ω" at the lower center is the RSET value previously saved in memory A (the upper part shows the present measurement). To modify a stored setting, use the jog/shuttle knobs (the modified setting will be updated upon completion of this modification).

```
7.13Ar10.1Ap 84.9V
--Rval<A>10.000Ω H--
```

3. Press the [SHIFT] + [RSET] (RANGE) keys. The range indication in the lowerpart of the display changes from "H" to "L," thereby modifying the range setting.

```
7.13Ar10.1Ap 84.9V
--Rval<A>10.000Ω L--
```

4. To modify the contents of a memory other than memory A, press the relevant memory key after pressing the [SHIFT] + [MEM] (DMEM) keys.

In this example, the [C] key is first pressed to move to memory C, and the jog/shuttle knobs are then used to modify the setting, in order to modify the RSET value in memory C.

```
7.13Ar10.1Ap 84.9V
--Rval<C>9.0909Ω H--
```

5. If the [SHIFT] + [MEM] (DMEM) keys or [ESC] key are pressed, the display returns to the state before the save operation was performed.

(b) Calling up set values from memory

If a setting saved in memory is called up and the [ENTER] key is pressed, that value will replace the present setting value immediately. A setting can be called up from memory in either the load-on or load-off state, provided that it is in the same operation mode.

1. To select the operation mode, press the [I SET], [R SET], [P SET], or [C.F] key, in accordance with the operation mode of the setting to be called up. In this example, the [R SET] key was pressed to enable the CR mode.

```
7.13Ar10.1Ap 84.9V
-- RSET 11.904Ω H--
```

2. Press the [A], [B], or [C] key to specify the target memory. The stored setting will appear in the lower part of the <<<< area when the key is pressed, and that value will replace the present setting when the [ENTER] key is pressed. If the stored setting is not appropriate, press the [ESC] key to cancel and operate again before pressing the [ENTER] key.

```
7.13Ar10.1Ap 84.9V
<< RSET 10.000Ω H<<
```

When the [ENTER] key is pressed, the display will appear as follows:

```
8.49Ar12.0Ap 84.9V
-- RSET 10.000Ω H--
```

In the above example, an RSET value of 10.000 Ω stored in memory A was called up to replace the present setting of 11.904 Ω. In the example below, an RSET value of 9.0909 Ω stored in memory B is called up to be used as a new setting. In this example, because range L was stored in memory B, the range has also been changed from "H" to "L."

```
8.49Ar12.0Ap 84.9V
<< RSET 9.0909Ω L<<
```

When the [ENTER] key is pressed, the display will appear as follows:

```
9.34Ar13.2Ap 84.9V
-- RSET 9.0909Ω L--
```

2.4.6 Backup memory

When the power is turned off, this instrument automatically memorizes and saves the settings (setup) that were in use when the power was turned off. The settings and initial values to be saved for setup are specified below. Those in parentheses are initial values.

- ISET value (0 A)
- RSET value (maximum value)
- PSET value (maximum value)
- CREST FACTOR value (1.4)
- Range in the CR mode (H)
- CF on/off (off)
- Contents of memories A, B, and C
(noted initial values in each operation mode)
- (Load off): Setup values for the load-on state will not be saved.

2.4.7 Alarms

(a) Types, operations, and indications of alarms

The instrument has the following types, operations, and indications of alarms:

Table 2-1

Type	Operation	Indication (lower part of the display)
Peak overcurrent protection (POCP)	If a current of 48 A _{peak} or greater is drawn, the instrument goes into the alarm state, the buzzer sounds, and then the instrument goes into the load-off state.	*ALARM* POCP
Overcurrent protection (OCP)	If a current of 11.5 A _{rms} or greater is drawn, the instrument goes into the alarm state, the buzzer sounds, and then the instrument goes into the load-off state.	*ALARM* OCP
Overvoltage protection (OVP)	If a voltage of 470 V _{peak} or greater is applied to the load terminals, the instrument goes into the alarm state, the buzzer sounds, and then the instrument goes into the load-off state.	*ALARM* OVP
Overpower protection (OPP)	If the combined applied voltage and the current drawn exceed 1150 W, the instrument goes into the alarm state, the buzzer sounds, and then the instrument goes into the load-off state.	*ALARM* OPP
Overheat protection (OHP)	If the temperature of the internal power supply unit rises abnormally, the instrument goes into the alarm state, the buzzer sounds, and then the instrument goes into the load-off state.	*ALARM* OHP
Protection of the internal power element	If the internal fuse blows, the instrument goes into the alarm state, the buzzer sounds, and then the instrument goes into the load-off state.	*ALARM* FUSE BREAK

-
- ⚠ CAUTION**
- If the overvoltage protection circuit (OVP) is activated, immediately check the output voltage of the unit under test. For more information, see "● Overvoltage" on page 1-12.
 - If the overheat protection device (OHP) is tripped, check the ambient temperature and ensure that there is no obstruction of the instrument's air-intake and air-exhaust ports of the instrument.
 - If any alarm other than those noted above occurs, immediately discontinue use of the instrument and contact Kikusui agent/distributor.
-

- NOTE**
- The alarm indicated on the display is that detected last.
-

(b) Clearing an alarm

A generated alarm can be cleared by turning the POWER switch off and then on again. However, the alarm will occur again unless its cause is eliminated.



3

Chapter 3 Remote Control

This chapter provides the procedure for programming the remote control features of the instrument using an external device such as a personal computer.

3.1 Initial Setting

(a) RS-232C protocol

In this instrument, the communications parameters are set as specified below.

Baud rate: 9600 bps Stop bits: 2 bits
 Data length: 8 bits Parity: None
 Flow control: XON/XOFF

(b) About the cables

RS-232C communication requires different cables, depending on the connector at the other end; always use the correct cable. (Connection is specified below.)

DTE-to-DTE connection (cross cable)

(For connecting a PC to the instrument)

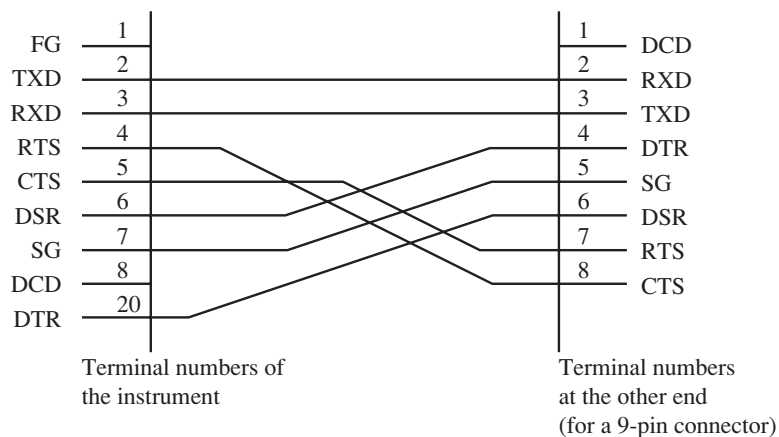
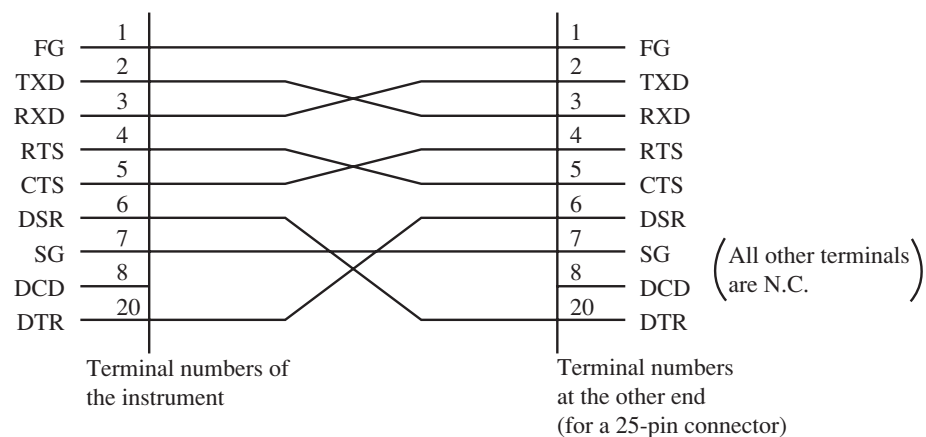

Fig. 3-1

(c) Response message terminator

In this instrument, the response message terminator is set to "CR+LF."

3.2 Programming Format

This section describes the general programming format.

(a) Program message terminator

The instrument can receive any of the three types of program message terminators specified below.

- CR
- LF
- CR + LF

3.2.1 Program Messages

The program messages to be sent from the RS-232C terminal to the instrument are as follows:

(a) Command message

This message activates the instrument. It is an ASCII-code character string consisting of a header, data, and other information. (For the header and data, see 3.2.1, Program Header and Program (Response) Data.)

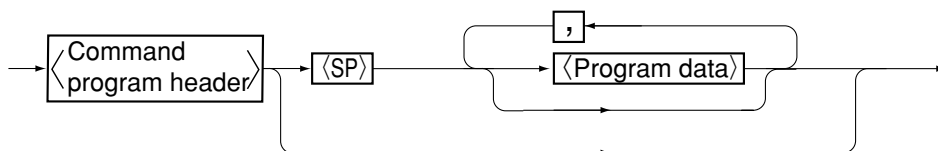

Fig. 3-2

(b) Query message

This message is for requesting information on the instrument. It is an ASCII-code character string consisting of a header with a question mark (?), data, and others.

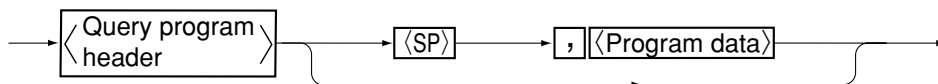

Fig. 3-3

NOTE

- This instrument does not allow use of the compound message delimiter ";".
-

3.2.2 Response Message

A response message is information returned from the instrument to the RS-232C terminal in response to a query message. It is an ASCII-code character string consisting of a header, numerical data, and other information. It is composed entirely of upper-case characters.

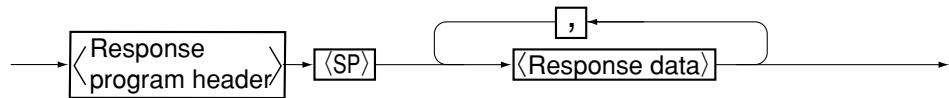

Fig. 3-4

3.2.3 Flow Control

Sending and receiving is controlled by XON/XOFF flow control, which is achieved through the use of device control (DC) codes (see the table below).

Table 3-1

	Function	ASCII code
DC1	Request to send	11h
DC3	Request to stop sending	13h

Control over transmission from the RS-232C terminal to the instrument:

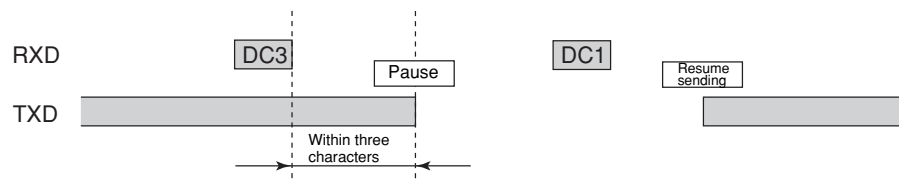

The instrument pauses data transmission within a three-character interval after receiving DC3.

Control over transmission from the instrument to the RS-232C terminal:

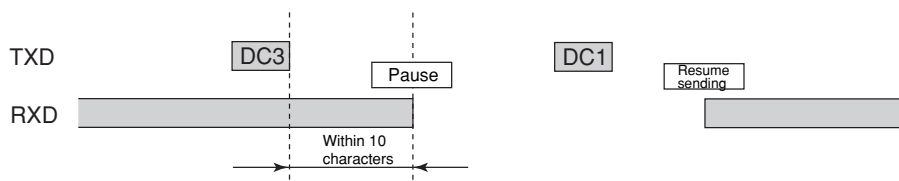

The RS-232C terminal should pause data transmission within a ten-character interval after receiving DC3.

Fig. 3-5

NOTE

- Sending and receiving should be controlled through the use of flow control. One-sided transmission may result in improper sending and receiving.
- If flow control is not used, a wait time of approximately 50 ms is required.
- An acknowledge message cannot be used in this instrument.

3.3 Device Message

This section describes the contents of device messages.

3.3.1 Program Header and Program (Response) Data

(a) Program header

The program header uses an ASCII-code character string. This manual expresses it in upper-case characters, but lower-case characters may be used as well. Note that no other characters, such as a space, should be placed between ASCII-code characters.

(b) Program (response) data

This is an argument following the program header, and its format is defined individually for each program header.

Decimal program data

Integers and decimals (such as 8 and 1.25). The units that can be decoded are as follows:

Current	KA, A, MA (Default: "A")
Power	KW, W, MW (Default: "W")
Resistance	KOHM, OHM, MOHM (Default: "OHM")
CREST FACTOR	No unit

Where K: 10^3 ; M: 10^{-3}

Figures to the right of the least significant digit will be rounded down.

- The instrument does not allow the use of exponents.
- Note that the instrument discards figures to the right of the least significant digit, rather than rounding them off.
- Number of significant digits

I SET value:	Two decimal places
P SET value:	Least significant digit of integers
CREST FACTOR value:	One decimal place
R SET value:	Five digits in total

For number program data

"1" and "0" are treated as symbols corresponding to "ON" and "OFF." Signs (+, -) and decimal points cannot be used and will result in an error.

For character program data

This is character-string data such as "ON" and "OFF."

3.3.2 Configuration of Device Messages

(a) Basic message

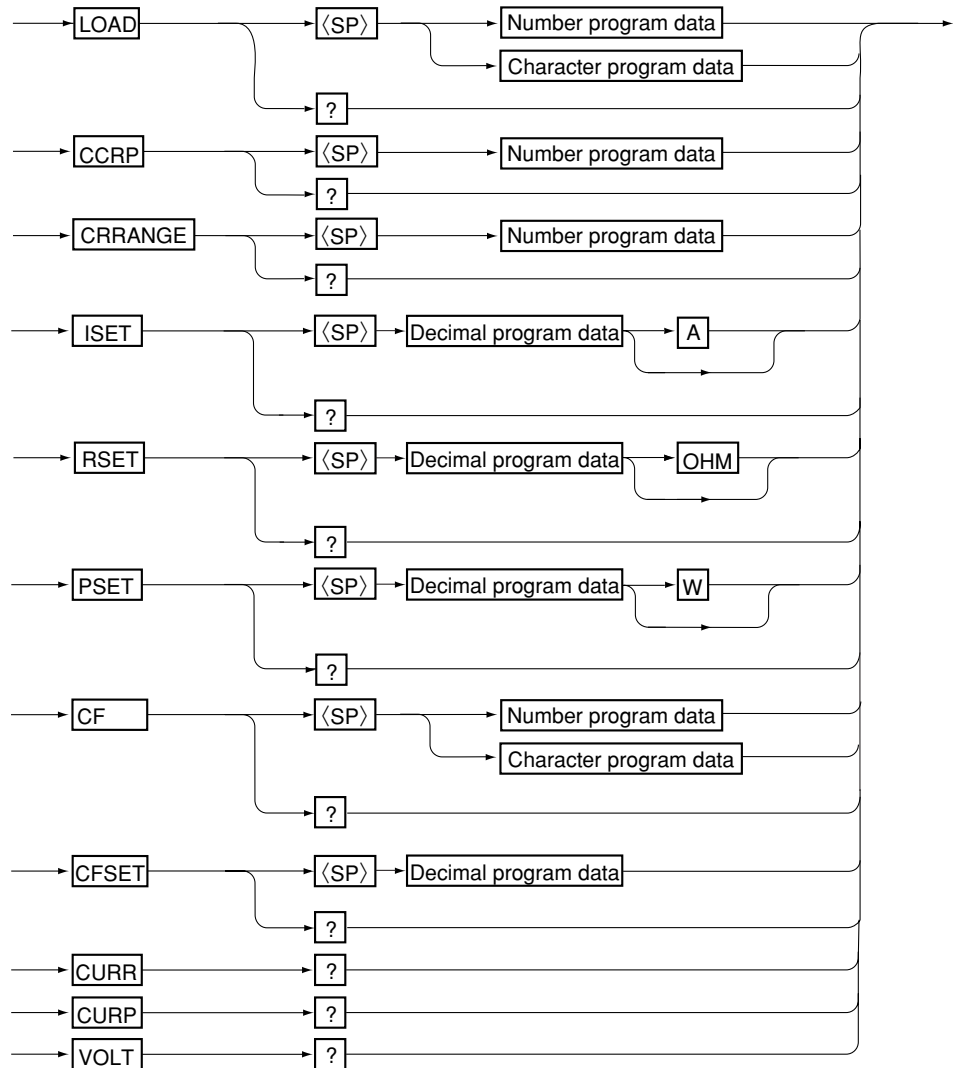

Fig. 3-6

Table 3-2

Header Name	Data	Operation
LOAD	0(OFF)	Turns the load (current) off
	1(ON)	Turns the load (current) on
LOAD?	—	Returns "0,1"
CCRP	1	Enables the CC mode
	2	Enables the CR mode
	3	Enables the CP mode
CCRP?	—	Returns "1,2,3"
CRRANGE	0	Sets the CR-mode range to "L"
	1	Sets the CR-mode range to "H"
CRRANGE?	—	Returns "0,1"
ISET	0 to maximum rated value [A]	Sets an ISET value
ISET?	—	Returns an ISET value
RSET	Minimum resistance value to maximum resistance value [OHM]	Sets an RSET value
RSET?	—	Returns an RSET value
PSET	0 to maximum rated value [W]	Sets a PSET value
PSET?	—	Returns a PSET value
CFSET	1.4 to 4.0	Sets a CREST FACTOR value
CFSET?	—	Returns a crest-factor value
CURR?	—	Returns the rms value of the input current
CURP?	—	Returns the peak value of the input current
VOLT?	—	Returns an input voltage value
CF	0(OFF)	Disables the crest factor
	1(ON)	Enables the crest factor
CF?	—	Returns "0,1"

(b) System message

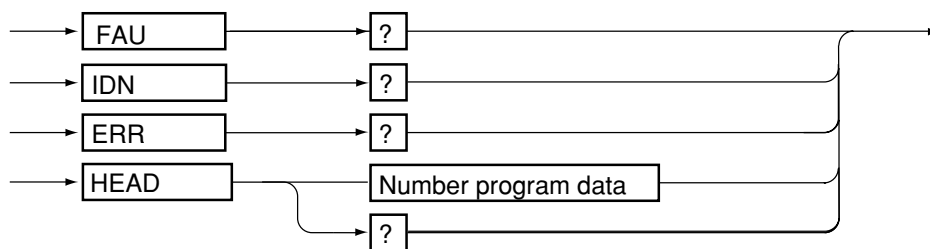

Fig. 3-7

Table 3-3

Header Name	Data	Operation
FAU?	—	Returns a fault register value
IDN?	—	Returns the model number and version number
ERR?	—	Returns an error register value
HEAD	1	Attaches the header to a response message
	0	Detaches the header from a response message
HEAD?	—	Returns "0,1"

(c) Communications environment setting and control code

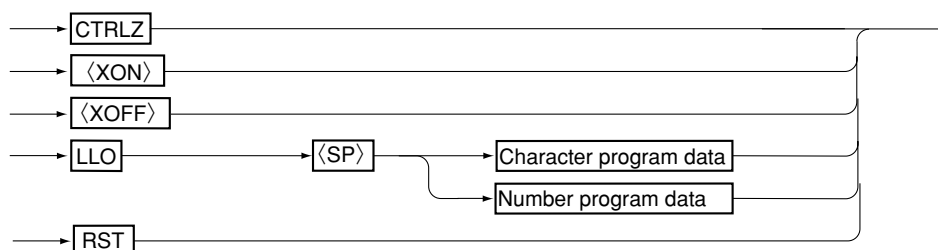

Fig. 3-8

Table 3-4

Header Name	Data	Operation
CTRLZ	—	Returns the control Z code (1Ah)
<XON> (11h)	—	Resumes a transmission made by the RS-232C interface (See 3.2.3, "Flow Control")
<XOFF> (13h)	—	Stops a transmission made by RS-232C
LLO	1(ON)	Sets local lockout
	0(OFF)	Cancels local lockout
LLO?	—	Returns "0,1"
RST	—	Resets to the factory-shipped settings

NOTE

- The instrument has no message regarding memory.

3.4 Assignment of Register Bits

A bit becomes "1" when the current state is "true."

The total of all true bits (total of the values in []) will serve as response data.

(a) Fault register

Table 3-5

Bit	Current state
0 [1]	Overvoltage protection operation (OVP)
1 [2]	Overcurrent protection or peak overcurrent protection operation (OCP, POCP)
2 [4]	Overheat protection operation (OHP)
3 [8]	Internal-electronic-element protection operation (FB)
4 [16]	Overpower protection operation (OPP)
5 [32]	CP-range operation (CP)
6 [64]	CR-range operation (CR)
7 [128]	CC-range operation (CC)

A bit of this register is latched and then cleared through a readout of a response message requested following transmission of "FAU?". To determine the current state, clear the register and then send "FAU?" again in order to read out the response message.

(b) Error register

Table 3-6

Bit	Current state
0 [1]	Error in the program header area
1 [2]	Error in another data area
2 [4]	Error in data out of range
3 [8]	Receipt of a message not currently enabled
4 [16]	Buffer full: CR or CF was not received within 35 characters.
5 [32]	—
6 [64]	—
7 [128]	—

A bit of this register is latched and then cleared through a readout of a response message requested following the transmission of "ERR?".



4

Chapter 4

Part Names and Functions

This chapter provides the names and functions of the switches, indicators, connectors, and other parts of the front and rear panels.

4.1 Front Panel

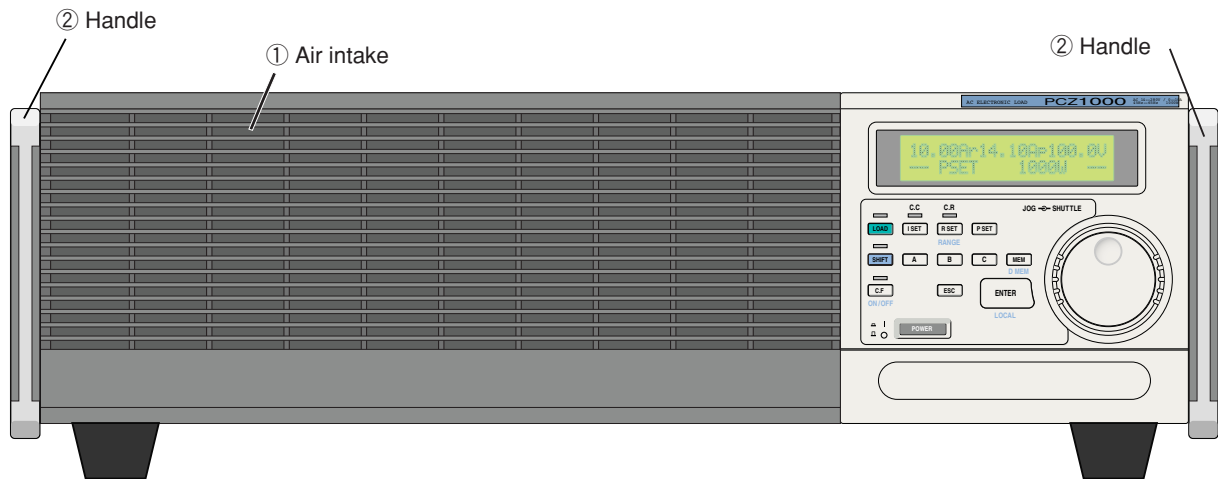
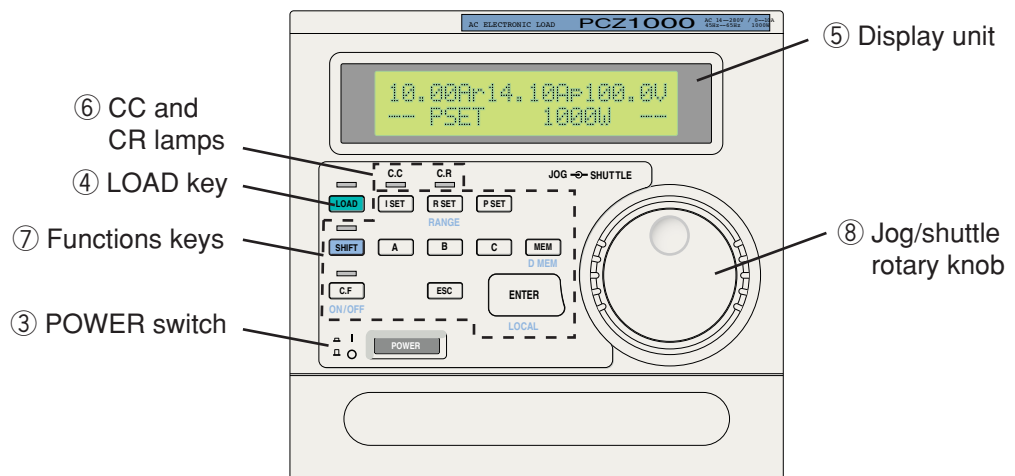

Fig. 4-1 Front Panel



- ① Air intake
Admits in air to cool the instrument

-
- ⚠ CAUTION**
- Do not block the air intake.
 - Inspect dust filters periodically (see chapter 5, Maintenance and Calibration).
-

- ② Handles
Pull them out for use when moving the instrument.



③ POWER switch

Turns the power to the instrument on and off. The power is on  (|) when this is pushed in, and off  (○) when it is not pushed in. When the power is turned on, the instrument automatically performs the self-test. As a result, it cannot be operated for approximately two seconds.

④ LOAD key

Starts or stops load current flow. When the key is pressed, the LED above it lights (green).

⑤ Display unit

Displays the measured values of the rms current, peak current, and rms voltage, parameters, CC, CR, CP, and CF settings, as well as a variety of messages.

⑥ CC and CR lamps

The CC lamp lights (red) when the [I SET] key is pressed, indicating that the CC mode is enabled. The CR lamp lights (yellow) when the [R SET] key is pressed, indicating that the CR mode is enabled. Further, when the [P SET] key is pressed, both the CC and CR lamps light, indicating that the CP mode is enabled. If the instrument is restricted by the operation range of another mode, the lamps blink.

Blinking of the CC lamp: The instrument is in the CP operation range.

Blinking of the CR lamp: The instrument is in the CC or CP operation range.

Blinking of both the CC and CR lamps:

The instrument is in the CC operation range.

NOTE

- For detailed descriptions of operations, see the Operating point of the instrument in Chapter 2.

-
- ⑦ Functions keys (For detailed functions and procedures, see Chapter 2, Basic Operation.)

I SET

This key enables the CC mode. The CC lamp above the key lights (red), and "ISET" appears on the display. This key enables the constant-current setting value (ISET) to be changed with the jog/shuttle knobs.

R SET (RANGE)

This key enables the CR mode. The CR lamp above the key lights (yellow), and "RSET" appears on the display. This key enables the constant-resistance setting (RSET) to be changed with the jog/shuttle knobs. To select the range function, press the [SHIFT] key. When the SHIFT lamp (green) above the SHIFT key lights, press this key. Each time the RSET (RANGE) key is pressed, the range is switched between "H" and "L."

P SET

Pressing this key enables the CP mode. Both the CC and CR lamps light and "PSET" appears on the display. This key enables the constant-power setting (PSET) to be changed with the jog/shuttle knobs.

C.F

To enable the CF function, press the [SHIFT] key. When the SHIFT lamp (green) lights, press this key. The lamp above this key lights (green), and "CREST FACTOR" appears on the display. This key enables the crest factor to be changed with the jog/shuttle knobs.

SHIFT

Another function is indicated in blue characters below each function key. To select this function, press the [SHIFT] key. When the lamp (green) above the SHIFT key lights, press the desired function key. Each time the [SHIFT] key is pressed, the lamp above it lights or goes off.

A

Calls up and displays a setting stored in memory A. In the memory save mode, this key selects memory A.

B

Calls up and displays a setting stored in memory B. In the memory save mode, this key selects memory B.

C

Calls up and displays a setting stored in memory C. In the memory save mode, this key selects memory C.

MEM (DMEM)

To save the present setting and range in the selected memory, select the memory save mode by pressing the [A], [B], or [C] key in this mode. To select the memory content modifying function (DMEM), press the [SHIFT] key to light the lamp above it (in green), and then press this key. With this function, only a setting stored in memory A, B, or C can be modified without changing the present setting. To reset each setting to the initial value, turn on the POWER switch with the [MEM] key held down.

ESC

Cancels the presently selected function.

ENTER (LOCAL)

Used to accept a setting called up from memory. To select the local function (LOCAL), press the [SHIFT] key. When the lamp (green) above the SHIFT key lights, press this key. Operation then switches from remote control (via an external computer) to front-panel control.

⑧ Jog/shuttle rotary knobs

Turning the inner jog knob provides fine adjustment, while turning the outer shuttle knob provides coarse adjustment. The adjustment rate depends on the extent to which the knob is turned.

4.2 Rear Panel

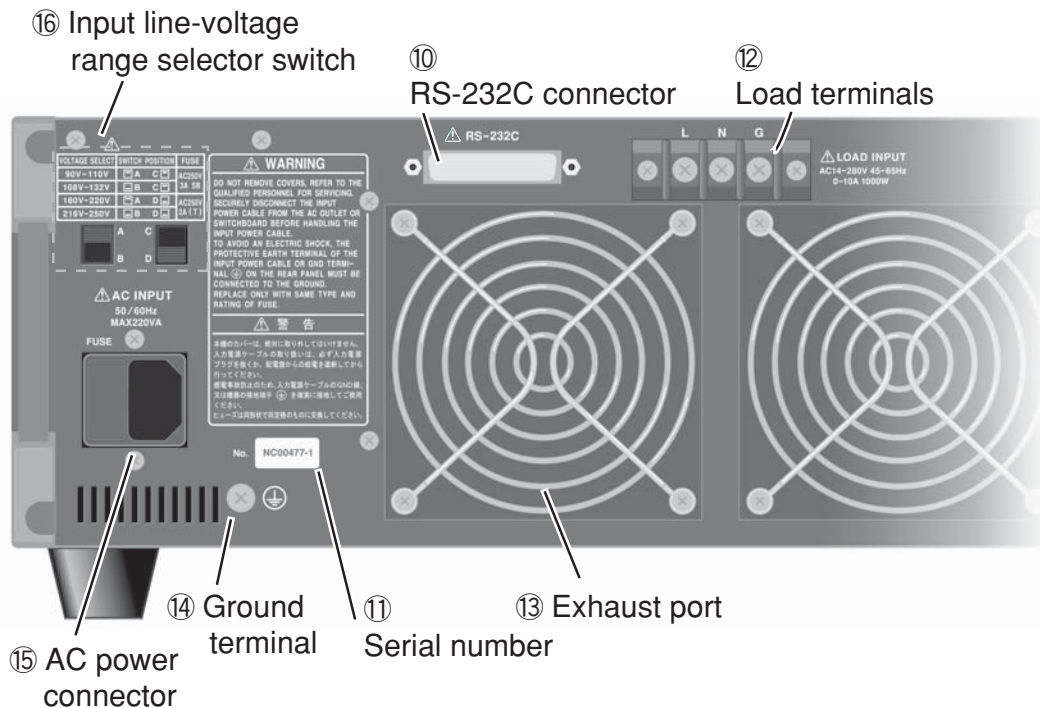

Fig. 4-2 Rear panel

- ⑩ RS-232C connector
Connects the instrument to the RS-232C I/O of a Personal computer.
- ⑪ Serial number
This indicates the serial number of the instrument.
- ⑫ Load terminals
Connect to the unit under test from which load current is to be drawn.

⚠ WARNING

- Do not touch the terminals when power is supplied.

⚠ CAUTION

- For connection to the terminals, use wire of appropriate gage and insulation.
- Connect conductors to the terminals properly; observe correct polarity.
- Firmly connect the conductors using the supplied screws.
- Do not exceed the instrument's terminal ratings.

⑬ Exhaust port

Equipped with a fan to exhaust hot air from the interior

⚠ CAUTION

- Exhaust air can be hot; approximately 40°C above room temperature.
 - For proper ventilation, provide at least 30 cm clearance at the rear of the instrument.
-

⑭ Ground terminal 

This terminal is used to ground the instrument. If grounding is not provided by the AC power cable, this terminal should be grounded separately.

⚠ WARNING

- When operating the instrument, always provide adequate grounding to prevent electric shock.
 - Connect the ground terminal to a solid electrical ground (safety ground).
-

⑮ AC power connector

This receptacle is for connecting the AC power cable. It is integrated with the fuse holder. The fuse holder contains a spare fuse.

⑯ Input line-voltage range selector switch

This switch should be set in accordance with the line voltage in use.

⚠ WARNING

- When setting the selector switch, always turn off the POWER switch and then unplug the AC power cable, or turn off the switch on the switch panel.
 - Always use the specified fuse.
-



5

Chapter 5

Maintenance and Calibration

This chapter describes the maintenance and calibration procedures for the instrument. To maintain the instrument's original performance for as long as possible, conduct periodic checks and maintenance.

5.1 Cleaning

5.1.1 Cleaning the Panel

To clean the panel, moisten becomes soiled, wet a piece of soft cloth with a diluted neutral detergent and wipe the panel gently.

-
- ⚠ WARNING** • When cleaning the panel, always turn off the POWER switch and either unplug the AC power cable or turn off the switch on the switchboard.
 - ⚠ CAUTION** • Do not use volatile solvents such as paint thinner or benzene to avoid discoloring the surface coating, erasing panel marking, or making the face of the display opaque.
-

5.1.2 Cleaning the Dust Filter

A clogged filter reduces the effect of the ventilating fan, which may result in instrument failure, reduced service life, and other problems. The filter should therefore be cleaned periodically.

Removing the louver

To remove the louver, push down on the lugs at its base, then pull the louver toward you. To install the louver, align the projections at its upper section with the recessed parts of the instrument, fit its lower section onto the instrument, then push up the lugs.

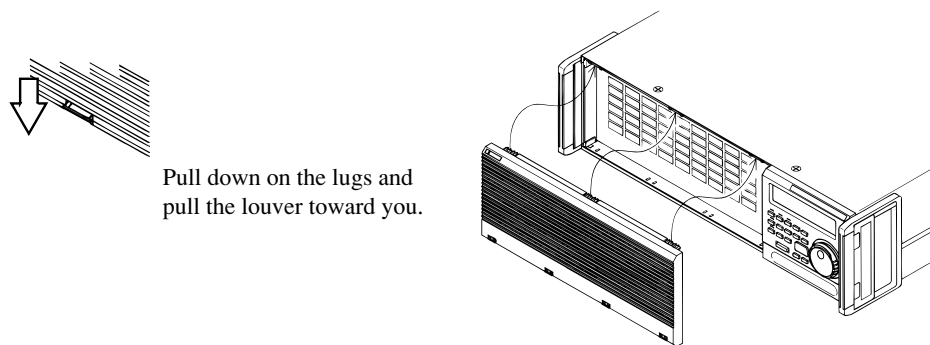

Fig. 5-1

-
- ⚠ WARNING** • When cleaning the instrument, always turn off the POWER switch, and either unplug the AC power cable or turn off the switch on the switchboard.
-

5.2 Inspection

■ AC power cable

Confirm that there is no damage to the jacket, and that the plug is firmly attached and free from cracks.

-
- ⚠ WARNING** • Breaks in the jacket may result in electric shock. If a break is found, immediately discontinue use of the instrument.
-

To purchase accessories, contact Kikusui agent/distributor.

5.3 Calibration

This product has been properly calibrated upon shipment from our factory. However, recalibration may be necessary after long-term use.

-
- ⚠ WARNING** • This device operates on and with high voltages; calibration can be dangerous. To have calibration performed, you may contact Kikusui distributor/agent.
-

5.4 Requesting Repair

If the instrument does not operate properly, double-check before requesting repair. Some common problems and remedies are listed below. If the problem persists, immediately unplug the AC power cable or turn off the switch on the switchboard. Contact Kikusui agent/distributor.

Symptom: The display remains blank after the POWER switch is turned on.

Check item	Possible cause	Action
Check that line voltage is present at the line power input terminals.	Break in the power cable	Check the power cable and replace it as necessary.
Check for a blown fuse.	Blown fuse	Replace it with the spare fuse provided or with one of the same rating (see 1.4, Checking the Input Power and Fuse).

Symptom: The display is dark after the POWER switch is turned on.

Check item	Possible cause	Action
Confirm that the line voltage is not low.	The line voltage is incorrect.	Make sure the line voltage is correct.
Check that the input line-voltage range selector switch is set properly.	Incorrect setting of the line-voltage range selector switch	Set the line-voltage range selector switch to match the line voltage. (See 1.4, Checking the Input Power and Fuse.)

Symptom: The input current is unstable or oscillation occurs.

Check item	Possible cause	Action
Confirm that no large loop is formed in the load wiring.	Large loop in load wiring	Change the load wiring. (See 1.8.1, Precautions on Load Wiring.)
Confirm that the load wiring is not too long.	Long load wiring	

6

Chapter 6 Specifications

This chapter provides the electrical and mechanical specifications of the instrument and its accessories.

6.1 Electrical Specifications

Table 6-1

Item		Specifications	
Input rating (AC)	Operation voltage *1		
	14 to 280Vrms		
	20 to 400Vpeak		
	Maximum current *2		
	10Arms 40Apeak		
Maximum power *3		1000W	
Frequency		45 to 65Hz	
Minimum operation start voltage *4		3Vpeak	
Constant-current (CC) mode *5	Setting range		0 to 10Arms
	Setting accuracy *9		Within $\pm(1\% + 0.1A)$
	Setting resolution		10mArms
	Stability	Line variations *10	Within $\pm 10mArms$
		Input-voltage variations *11	Within $\pm 100mArms$
Temperature coefficient (at the rated current)		200PPM/°C (typical)	
Constant-resistance (CR) mode *6	Setting range	H range	1 to 1k Ω
		(Full current at 10 V)	1 to 1mS *20
		L range	10 to 10k Ω
	Setting resolution	(Full current at 100 V)	0.1 to 0.1mS *20
		H range	1mS *20
	Setting accuracy (in current terms) *9, 12	L range	0.1mS *20
		Stability Input-voltage variations *13	
Stability		Within $\pm 10\%$	
Constant-power (CP) mode *7	Setting range		100 to 1000W
	Setting accuracy *9, 14		Within $\pm 5\%$
	Setting resolution		1W
	Input-voltage variations *15		Within $\pm 5\%$
Crest-factor (C.F) function *8	Setting range		1.4 to 4.0
	Resolution		0.1
Ammeter (RMS display mode)	Number of display digits (full scale)		10.00Arms
	Accuracy *9		Within $\pm 1\%$ of FS
Ammeter (peak display mode)	Number of display digits (full scale)		40.0Apeak
	Accuracy *9		Within $\pm 2\%$ of FS
Voltmeter	Number of display digits (full scale)		300.0Vrms
	Accuracy *9		Within $\pm 1\%$ of FS
Protection function	Peak overcurrent protection (POCP) *16		Approximately 48Apeak
	Overcurrent protection (OCP) *17		Approximately 11.5Arms
	Overvoltage protection (OVP) *16		Approximately 470Vpeak
	Overpower protection (OPP) *17		Approximately 1150W
	Overheat protection (OHP) *18		-
	Internal-power-element protection		Internal fuse blown
Input power (AC)	Voltage range (nominal value) *19	1	90 to 110(100)Vrms
		2	108 to 132(120)Vrms
		3	180 to 220(200)Vrms
		4	216 to 250(240)Vrms
	Frequency		50/60Hz
	Power consumption (apparent power)		Approximately 200VA

Table 6-2

Item		Specifications
Withstand voltage	Primary side to case	1500 VAC for 1 minute
	Primary side to load input terminals	1500 VAC for 1 minute
	Load input terminals to case	500 VAC for 1 minute
Insulation resistance	Primary side to case	1000 VDC at 20 M Ω or more
	Primary side to load input terminals	1000 VDC at 20 M Ω or more
	Load input terminals to case	1000 VDC at 20 M Ω or more
Temperature and humidity ranges	Operating temperature range	0 to 40 $^{\circ}$ C
	Operating humidity range	30 to 80%RH(no condensation)
	Storage temperature range	- 10 to 50 $^{\circ}$ C
	Storage humidity range	20 to 90%RH(no condensation)
Dimensions (case)		430W \times 400D \times 128Hmm
Weight		Approximately 22 kg

- *1 Input-voltage range in which the rated input current can flow
- *2 For an input voltage of 100 Vrms or greater, the maximum current is derated at the rated input power (1000 W)
- *3 For an input voltage of 100 Vrms or less, the maximum power is limited by the rated input current (10 Arms).
- *4 Minimum input voltage at which the input current starts to flow
- *5 The input-current waveform does not change with changes in the input-voltage waveform.
The rms value of the input current is kept constant (response rate: approximately 1 s).
(Response rate: Time required to reach $\pm 10\%$ of the steady value (value reached 5 seconds or more after state change))
- *6 The input-current waveform does not change with changes in the input-voltage waveform.
This mode allows an input current (rms value) proportional to the rms value of the input voltage to flow (response rate: approximately 1 s).
- *7 The input-current waveform does not change with changes in the input-voltage waveform.
This mode allows an input current (rms value) inversely proportional to the rms value of the input voltage to flow (response rate: approximately 1 s).
- *8 Varies the angular width of the current at the approximate input-voltage peak, based on the sinusoidal-current waveform
- *9 At room temperature($23 \pm 5^{\circ}$ C)
- *10 Changes in the input current when variations in the rated-voltage range are given at an input voltage of 100 Vrms and an input current of 10 Arms, based on the nominal value of the input line voltage
- *11 Changes in the input current when the input voltage is changed from 10 Vrms to 280 Vrms at an input current of 3.57 Arms (rating at an input voltage of 280 Vrms)
- *12 At an input voltage of 100 Vrms
- *13 Changes in the resistance value when the input voltage is varied from 10 Vrms to 100 Vrms at an input current of 0.5 A or more
- *14 At an input voltage of 100 Vrms
- *15 Changes in the power value when the input voltage is varied from 10 Vrms to 100 Vrms
- *16 Turns off the [LOAD] key within 20 ms
- *17 Turns off the [LOAD] key within 3 ms
- *18 Detects the internal-heat-sink surface temperature to turn off the [LOAD] key
- *19 Switching
- *20 S represents the unit of conductance (siemens).
Conductance [S] = 1/resistance value [Ω]
Conductance [S] \times input voltage [V] = load current [A]

6.2 Dimensional Diagram

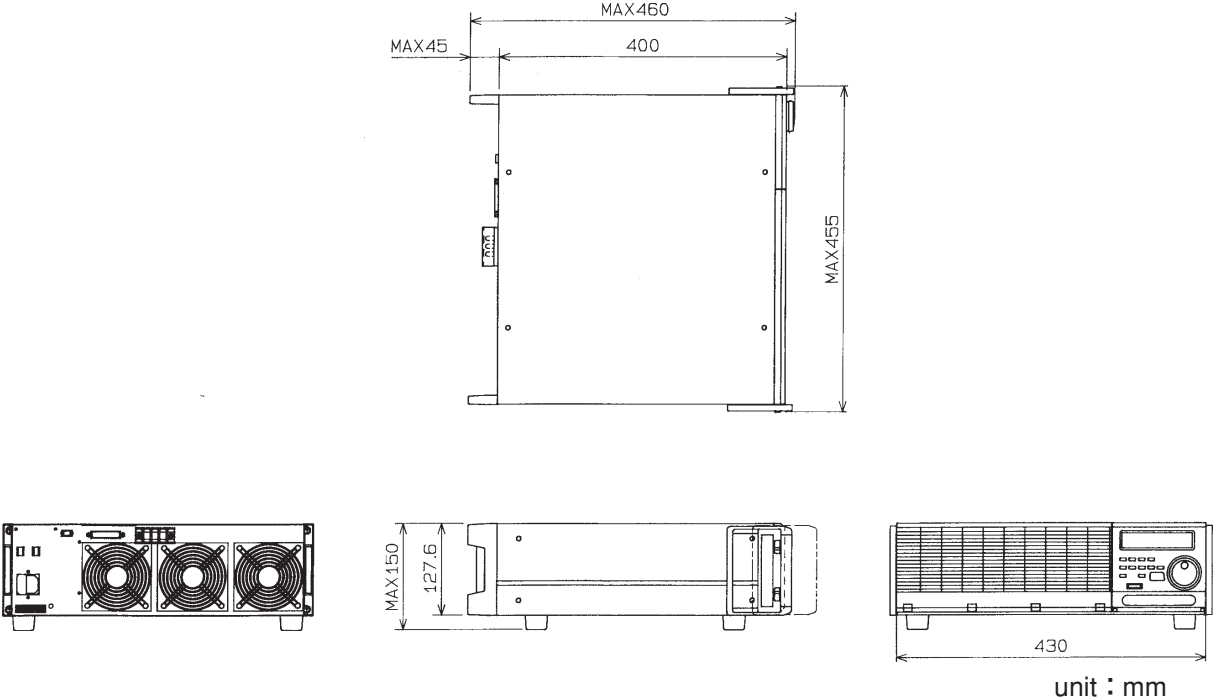

Fig. 6-1

6.3 Accessory

Table 6-3

Item	Quantity	Remarks
AC power code	1	
Operation Manual	1	
Fuse in different rating	2	See Table 6-4
"Filter" Cleaning Sticker	1	

The following fuses are included in the package.

Table 6-4

Product for 100V power system		Product for 200V power system	
Inside the AC inlet 100V rating	Provided separately 200V rating	Inside the AC inlet 200V rating	Provided separately 100V rating
3A (S.B) 1 piece	2A (T) 2 pieces	2A (T) 1 piece	3A (S.B) 2 pieces

6.4 Options

■ Rack-mount frames

KRB3 (for EIA-standard-compatible rack)

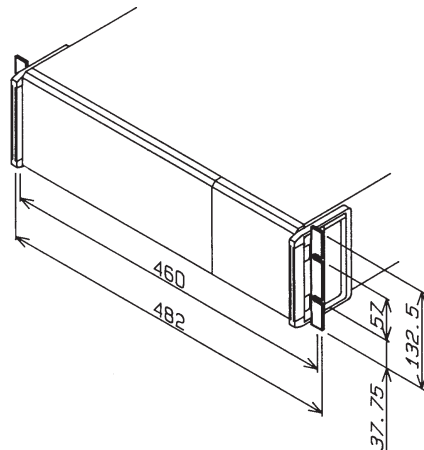

KRB150 (for JIS-standard-compatible rack)

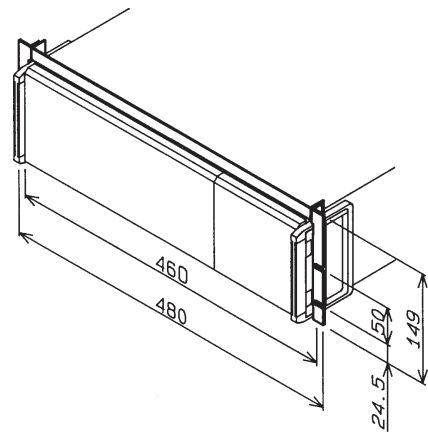

■ Auxiliary load terminals (factory-mounted option)

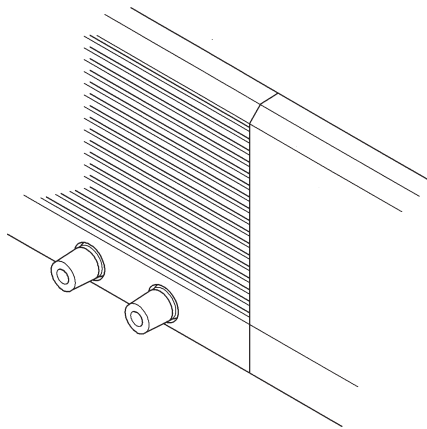

These terminals enable connection of the unit under test, in order to allow a current to flow in a simplified way. They are directly connected to the load terminals on the rear panel. Note that the specifications (such as the setting accuracy and stability) may not be met.

⚠ WARNING

- Do not touch the terminals while power is applied.
- Note that the voltage applied to the auxiliary load terminals is output to the load terminals on the rear panel.
- When the unit under test is connected to the auxiliary load terminals, never attempt to connect another unit to the load terminals on the rear panel of the instrument.

⚠ CAUTION

- For connection to the terminals, use wire of appropriate gage and insulation.
- Connect conductors to the terminals properly: observe correct polarity.
- Observe the instrument's terminal ratings.

These options should be selected when the instrument is ordered.

Index

Command

<XOFF> 3-8
<XON> 3-8
CCRP 3-7
CCRP? 3-7
CF 3-7
CF? 3-7
CFSET 3-7
CFSET? 3-7
CRRANGE 3-7
CRRANGE? 3-7
CTRLZ 3-8
CURP? 3-7
CURR? 3-7
ERR? 3-8
FAU? 3-8
HEAD 3-8
HEAD? 3-8
IDN? 3-8
ISET 3-7
ISET? 3-7
LLO 3-8
LLO? 3-8
LOAD 3-7
LOAD? 3-7
PSET 3-7
PSET? 3-7
RSET 3-7
RSET? 3-7
RST 3-8
VOLT? 3-7

A

AC power code 1-6
Alarm 2-25

B

Backup memory 2-24
Basic message 3-6

C

Calibration 5-3
capacitor-input full-wave rectified waveform 2-5
CC mode 2-7
CF function 2-8
Command message 3-3
Communications environment setting 3-8
Conductance 6-3
Constant-current P-1
Constant-current mode 2-7
Constant-power P-1
Constant-power mode 2-7
Constant-resistance P-1
Constant-resistance mode 2-7
Control code 3-8
CP mode 2-8
CR mode 2-7
Crest-factor function 2-7
Current waveform 2-4
Current waveform distortion 2-9

D

Distortion 2-6
Dust Filter 5-2

E

Error register 3-9

F

Fault register 3-9
Flow Control 3-4
Fuse 1-6

G

Grounding 1-9

H

H range 2-14
Handle 1-5

I

Inductance 1-11
Initial value 2-24

L

L range 2-16
Line voltage range selector switches 1-6
Load terminal 1-11
Load terminal cover 1-13
Load wiring 1-11

M

Memory 2-20

O

Oscillation 1-11
Overvoltage 1-12

P

Program (response) data 3-5
Program header 3-5
Program Message 3-3
Program message terminator 3-3

Q

Query message 3-3

R

Repair 5-4
Response Message 3-4
Response message terminator 3-2
ROM Version P-2
RS-232C protocol 3-2

S

setup value 2-24
[SHIFT] key 2-3
Siemens 6-3
Synchronization 2-9
System message 3-8

