

# Operation Manual

Line Impedance Network  
LIN Series

**LIN1020JF**  
**LIN3020JF**  
**OP01-LIN1020JF**

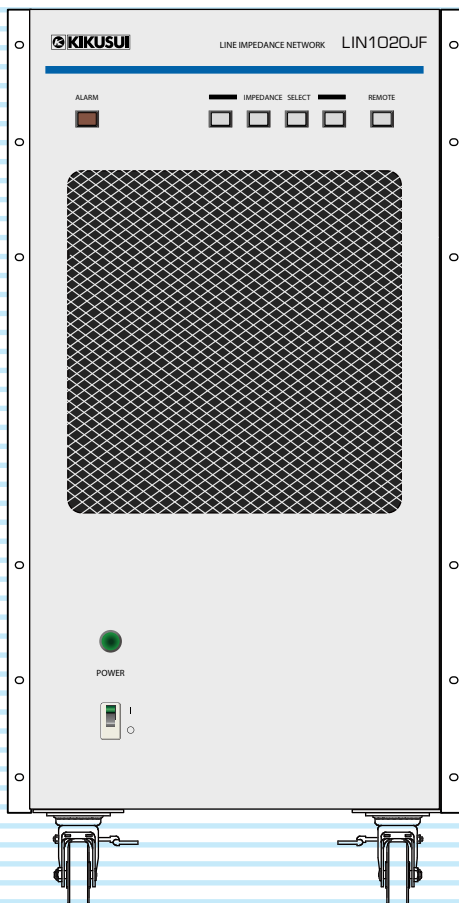

- 1 General Description
- 2 Description of Parts
- 3 Wiring the Test System
- 4 Wiring the LIN1020JF
- 5 Wiring the LIN3020JF
- 6 Operation
- 7 Remote Control
- 8 Specifications
- Appendix

Thank you for purchasing the LIN1020JF, LIN3020JF, or OP01-LIN1020JF Line Impedance Network.

## About the manuals

This manual provides an overview of the product and notes on usage. It also explains how to configure it, operate it, perform maintenance on it, and so on.

This manual only provides general information about the AC power supplies (PCR-LE and PCR-LE2 series) that are used in combination with this product. For details on the AC power supplies, see the operation manual provided with the respective product.

You can download the most recent version of these manuals from the Kikusui Electronics Corporation website (<http://www.kikusui.co.jp/en/download/>).

## Target audience of these manuals

This operation manual is intended for users who will use the LIN1020JF, LIN3020JF, or OP01-LIN1020JF Line Impedance Network. It is also intended for instructors who will teach these users.

Explanations are given under the presumption that the reader has knowledge of the electrical aspects of line impedance networks.

## How to read this manual

This manual is designed to be read from beginning to end. We recommend that you read it thoroughly before using this product for the first time.

## Copyrights

The contents of this manual may not be reproduced, in whole or in part, without the prior consent of the copyright holder.

The specifications of this product and the contents of this manual are subject to change without prior notice.

Copyright© 2014 Kikusui Electronics Corporation

## Notations used in this guide

- In this manual, the following products are also referred to simply by their model names.  
LIN1020JF Line Impedance Network as the LIN1020JF  
LIN3020JF Line Impedance Network as the LIN3020JF  
OP01-LIN1020JF Line Impedance Network as the OP01-LIN1020JF or OP01
- In this manual, the following line impedance networks are also referred to collectively as the LIN-JF.  
LIN1020JF  
LIN3020JF  
OP01-LIN1020JF
- In this manual, the following AC power supplies are also referred to collectively as the AC power supply.  
PCR-LE Series  
PCR-LE2 Series
- The term "PC" is used to refer generally to both personal computers and workstations.
- This manual also uses the following abbreviations to refer to the following wiring systems.  
Single-phase two-wire as 1P2W  
Single-phase three-wire as 1P3W  
Three-phase three-wire as 3P3W  
Three-phase four-wire as 3P4W
- This manual refers to each phase of a wiring system as U phase, V phase, W phase, and N phase. These phases correspond respectively to the R, S, T, and N phases used in other manufacturers' products.
- The following markings are used in the explanations in this manual.

### **WARNING**

Indicates a potentially hazardous situation which, if ignored, could result in death or serious injury.

### **CAUTION**

Indicates a potentially hazardous situation which, if ignored, may result in damage to the product or other property.

### **NOTE**

Indicates information that you should know.

### **DESCRIPTION**

Explanation of terminology or operation principle.

### **See**

Indicates a reference to detailed information.

# Contents

Notations used in this guide .....	2
Checking the package contents .....	5
Options .....	5
Safety markings .....	6
Safety precautions .....	6
Precautions when choosing the installation location .....	7
Precautions for moving the product .....	8

## 1 General Description

Product Features .....	9
Impedance Construction .....	10
Overview of the Test System .....	11
Device test system .....	12
Grid-connected device test system .....	14

## 2 Description of Parts

OP01-LIN1020JF .....	17
INPUT and OUTPUT terminals .....	18
VOLTAGE SENSING OUTPUT terminal .....	18
AC INPUT (control power supply input terminal) .....	18
PCR CONTROL terminal .....	19
EXPAND terminal .....	19
CONTROL INPUT and STATUS OUTPUT terminals .....	19
USB port .....	19

## 3 Wiring the Test System

Removing the Terminal Cover .....	20
Connecting the Control Power Cable .....	20
Wiring the Test Circuit .....	21
Connecting the Control Terminals .....	22
Connecting the PCR CONTROL terminal .....	22
Connecting the EXPAND Terminal .....	24

## 4 Wiring the LIN1020JF

LIN1020JF + one PCR-LE: single-phase .....	26
LIN1020JF + one PCR-LE2: single-phase .....	28

Combination Wiring of LIN1020JF and OP01-LIN1020JF .....	30
----------------------------------------------------------	----

LIN1020JF + OP01 + two PCR-LEs: single-phase and single-phase three-wire .....	30
LIN1020JF + OP01 + three PCR-LEs: single-phase and three-phase .....	32
LIN1020JF + OP01 + one PCR-LE2: single-phase and three-phase .....	34

## 5 Wiring the LIN3020JF

LIN3020JF + one PCR-LE: single-phase .....	38
LIN3020JF + two PCR-LE: single-phase and single-phase three-wire .....	40
LIN3020JF + three PCR-LEs: single-phase and three-phase .....	42
LIN3020JF + one PCR-LE2: single-phase .....	44
LIN3020JF + one PCR-LE2: single-phase and three-phase .....	46

## 6 Operation

Powering On .....	48
Turning on the POWER switch .....	48
Panel Operation .....	48
Selecting the impedance .....	48
Configuring the AC Power Supplies .....	49
Setting hardware sensing .....	49
Setting the response .....	49
Output current limit of the AC power supplies .....	50
Power level supplied from the test circuit to the EUT .....	50
Configuring the KHA3000 .....	50
Handling Overheat Alarms .....	51

## 7 Remote Control

Switching to Remote Control Mode .....	52
Switching between panel control and remote control .....	52
Controlling the Product Using Contact Signals .....	53
CONTROL INPUT terminal .....	53
STATUS OUTPUT terminal .....	53
Controlling the Product Using USB .....	55
USB port .....	55
Installing the driver .....	56
Checking the feature .....	56

# 8 Specifications

## Appendix A

Troubleshooting . . . . . 62

## Appendix B

Connecting the PCR-LE and  
PCR-LE2 . . . . . 63

PCR-LE . . . . . 64  
    Output terminal . . . . . 64  
    Sensing . . . . . 65  
PCR-LE2 . . . . . 66  
    Output terminal . . . . . 66  
    Sensing . . . . . 68

## Appendix C

KHA3000 Input Terminal . 69  
    Voltage input terminal . . . . . 69  
    Current input terminal . . . . . 69  
    Delta transformation (star-delta transfor-  
    mation) . . . . . 70



## Checking the package contents

When you receive the product, check that all accessories are included and that the accessories have not been damaged during transportation. If something is damaged or missing, contact your Kikusui agent or distributor. We recommend that you save all packing materials, in case the product needs to be transported at a later date.

### Accessories for LIN1020JF, LIN3020JF, and OP01-LIN1020JF

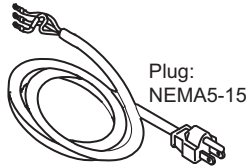

Plug:  
NEMA5-15

For nominal power supply voltages  
100 V and 120 V

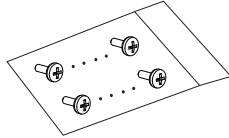

Use these when the rack mount  
bracket is removed.

- Control power cable (1 pc.)  
[3 m] [85-10-0650]
- Screws (8 pcs.)

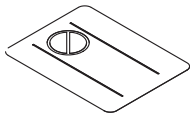

- Heavy object warning  
label (1 pc.)  
[A8-900-157]

### Accessories for LIN1020JF and LIN3020JF

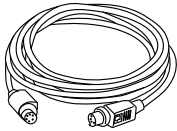

- Control cable (1 pc.)  
[3 m] [85-50-0390]

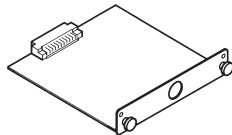

- Control board (1 card)  
[UA-1894-01]

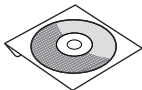

- CD-ROM (1 disc)  
API-USBP (WDM) driver  
software by CONTEC

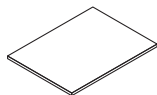

- Operation manual (1 copy)

### Accessories for OP01-LIN1020JF

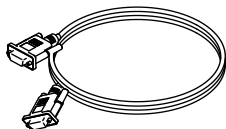

- OP01-LIN1020JF  
Control cable  
(1 pc.) [91-80-9922]

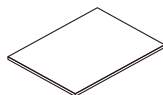

- Accessory manual  
(1 pc.)

## Options

The following options can be used with this product.

- **Control power cable (heavy PVC jacketed three-core)**

This cable is for connecting to the control power supply input (AC INPUT) terminal on the rear panel of the product.

Model: AC5.5-3P3M-M4C

Type: Heavy PVC jacketed three-core cable

Length: 3 m

Nominal cross-sectional area: 5.5 mm<sup>2</sup> (AWG10 equivalent)

Crimping terminal size: M4



For nominal power supply voltages  
200 V and 240 V

## Safety markings

For the safe use and safe maintenance of this product, the following symbols are used throughout this manual and on the product. Note the meaning of each of the symbols to ensure the safe use of the product. (Some symbols are not used depending on the product.)



Indicates that a high voltage (over 1000 V) is used here.

Touching an area marked with this symbol without taking proper precautions may cause a fatal or serious electric shock. If you must touch an area marked with this symbol, ensure that the area is safe before you do so.

DANGER

Indicates an imminently hazardous situation which, if ignored, will result in death or serious injury.



WARNING

Indicates a potentially hazardous situation which, if ignored, could result in death or serious injury.



CAUTION

Indicates a potentially hazardous situation which, if ignored, may result in damage to the product and other property.



Indicates a prohibited act.



Indicates a warning, caution, or danger. When this symbol is marked on the product, see the relevant section in this manual.



Indicates that parts will become hot. When this symbol is marked on the product, see the relevant section in this manual.



Protective conductor terminal.



Chassis (frame) terminal.



On (power supply).



Off (power supply).



In position of a bi-stable push control.



Out position of a bi-stable push control.

## Safety precautions

The following safety precautions must be observed to avoid fire hazards, electric shock, accidents, and device failures. Keep them in mind and make sure to observe them.

Using the product in a manner that is not specified in this manual may impair the protection functions provided by the product.



### Users

- This product must be used only by qualified personnel who understand the contents of this operation manual.
- If unqualified personnel are to use the product, be sure the product is handled under the supervision of qualified personnel (those who have electrical knowledge). This is to prevent the possibility of personal injury.



### Purpose of use

- Never use the product for purposes other than the product's intended use.
- Do not connect electrical appliances that are normally used with commercial power supplies as the PCR-LE Series load.
- This product is not designed or manufactured for general home or consumer use.

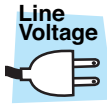

### Input power

- Always use the product within the rated input line voltage range.
- Use the power cable provided to apply power. For details, see the appropriate pages in this manual.
- This product conforms to IEC Overvoltage Category II (energy-consuming equipment that is supplied from a fixed installation).



### Cover

- Some parts inside the product are hazardous. Do not remove the external cover.



### Grounding

- This product conforms to IEC Safety Class I (equipment that has a protective conductor terminal). To prevent electric shock, be sure to connect the protective conductor terminal of the product to electrical ground (safety ground).



### Operation

- If you notice a malfunction or abnormality in the product, stop using it immediately, and remove the power cable plug from the outlet or remove the power cable from the switchboard. Make sure the product is not used until it is completely repaired.
- Make sure to use output cables, load cables, and other cables that run current have sufficient current capacity.
- Do not disassemble or modify the product. If you need to modify the product, contact your Kikusui agent or distributor.



### Maintenance, Inspection and Calibration

- To maintain the performance and safe operation of the product, we recommend periodic maintenance, inspection, cleaning, and calibration.
- To prevent the possibility of electric shock, remove the power plug from the outlet, or turn off the switchboard before carrying out maintenance or inspection. Do not remove the external cover.
- Check periodically that there are no tears or breaks in the power cable.
- If the panel needs cleaning, gently wipe it using a soft cloth with water-diluted neutral detergent. Do not use volatile chemicals such as benzene or thinner.
- To maintain the impedance characteristics of the product, inspect the relay periodically and check that the relay contact resistance is sufficiently small. Depending on the result of an inspection, the relay may need to be replaced.
- The product is calibrated before shipment. To maintain long-term performance, we recommend periodic calibration. To have your product calibrated, contact your Kikusui distributor or agent.



### Service

- Kikusui service engineers will perform internal service on the product. If the product needs adjustment or repairs, contact your Kikusui agent or distributor.

## Precautions when choosing the installation location

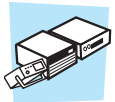

Be sure to observe the following precautions when installing the product.

- Do not use the product in a flammable environment.**  
 Risk of explosion or fire. Do not use the product near alcohol, thinner, or other combustible materials, or in an environment containing such vapors.
- Avoid locations where the product is exposed to high temperatures or direct sunlight.**
- Do not install the product near a heater or in areas subject to drastic temperature changes.**  
 The product's operating temperature range is 0 °C to 50 °C.
- Avoid humid environments.**  
 Do not install the product in high-humidity locations, such as near a boiler, humidifier, or water supply.  
 Condensation may form even within the operating humidity range. If this happens, do not use the product until the condensation dries up completely.  
 The product's operating humidity range is 20 %rh to 80 %rh (no condensation).
- Be sure to use the product indoors.**  
 This product is designed for safe indoor use.
- Do not install the product in a corrosive environment.**  
 Do not install the product in a corrosive atmosphere or in an environment with a high level of sulfuric acid mist or other types of poisonous gas. Doing so may damage the terminals or cause the internal conductors to corrode. This can lead to malfunction, damage to the product, or fire.
- Do not install the product in a dusty location.**  
 Accumulation of dust can lead to electric shock or fire.
- Do not use the product in a poorly ventilated location.**  
 Secure adequate space around the product so that air can circulate around it.  
 Allow at least 50 cm of space between the air inlet/outlet and the wall (or obstacles).
- Do not place objects on top of the product.**  
 Placing objects (especially heavy ones) on top of the product can lead to malfunctions.
- Do not use the product in a location subject to strong magnetic or electric fields or in a location where the input power supply signal contains large amounts of distortion or noise.**  
 Doing so may cause the product to malfunction.  
 Noise generated by this product may affect other devices.
- Use the product in an industrial environment.**  
 Using this product in a residential area may interfere with radio and TV broadcast reception.  
 In such case, users may need to take special measures to reduce the electromagnetic radiation.
- Affix the heavy object warning label.**  
 Affix the heavy object warning label to the product where it can be readily seen. For this product's weight, see the specifications.

- Do not install the product on an inclined surface or in a location subject to vibrations.**  
 The product may fall or tip over and cause damage and injury.
- Lock the casters.**  
 Use the caster lock levers to lock the casters.

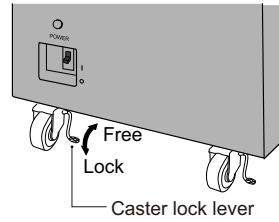

- Use the base hold angles.**  
 To prevent the product from falling over, use the base hold angles to fix the product to the installation location.

When the product is shipped from the factory, base hold angles are attached to the left and right sides of the bottom of the product.

Remove the base hold angles from the product.

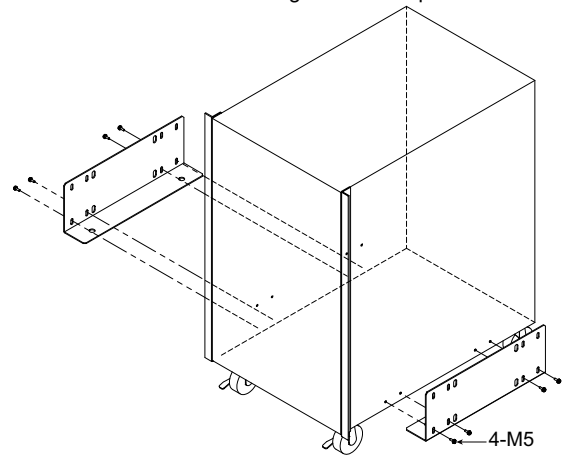

Face the base hold angles away from the product, and fix them in place using the screws that you removed.

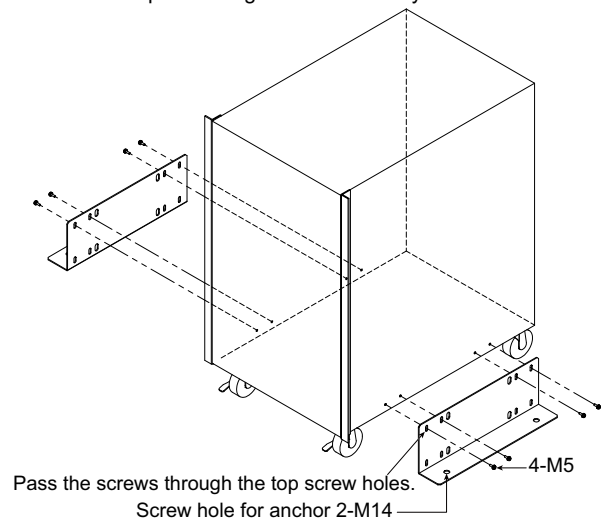

## Precautions for moving the product



Note the following points when moving the product to the installation location or when transporting the product.

- **Turn off the POWER switch.**  
Moving the product with the POWER switch turned on may cause electric shock or damage to the product.
- **Remove all wiring.**  
Moving the product with the cables connected may cause wires to break or injuries due to the product falling over.
- **Remove the base hold angles.**  
Remove the base hold angles or return them to the factory default condition.

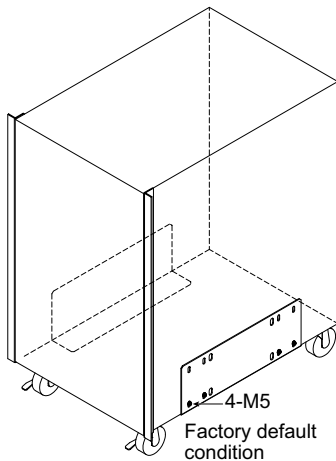

- **Unlock the casters.**  
Use the caster lock levers to unlock the casters. Moving the product without releasing the lock may cause injuries due to the product falling over. Move the product over a surface that is as flat as possible.
- **Do not move the product by yourself.**  
Be sure to have two or more people move the product. Exercise special care when carrying the product over a slope or across steps.  
Check the weight that is indicated on the heavy object warning label that you affixed at the time of installation.  
If you are using a forklift, be sure to slide the forks under the bottom of the product, check that the product is stable, and then raise the product.  
If you are using a band or similar item to raise the product with a crane, be sure to slide the band under the bottom of the product, check that the product is stable, and then raise the product. There are four M10 eye bolt screw holes on the top of the product.  
When you move the product, do not tip the product on its side or turn it upside down.
- **When transporting the product, be sure to use the original packing materials.**  
Otherwise, damage may result from vibrations or from the product falling during transportation.
- **Be sure to include this manual.**



# 1 General Description

This chapter describes the product's impedance features and impedance construction and provides an overview of the test system.

## Product Features

This product contains JIS- and IEC-compliant impedances required for harmonic and flicker testing of devices connected to power distribution systems. A test system can be configured easily by combining this product with AC power supplies.

- **Support for as many phases as there are in the input power supplies of EUTs**

The LIN1020JF is for single-phase devices. The LIN3020JF is for single-phase and three-phase devices. You can use these to perform JIS harmonic tests (100 V and 200 V systems) and IEC flicker tests.

- **Support for three-phase devices with the OP01-LIN1020JF**

The OP01-LIN1020JF is used in combination with the LIN1020JF. You can use this combination to perform JIS harmonic tests for single-phase devices, single-phase three-wire devices and three-phase devices (100 V and 200 V systems) and IEC flicker tests.

- **Impedance elements support different wiring systems**

Impedance elements support single-phase two-wire, single-phase three-wire, three-phase three-wire, and three-phase four-wire systems. The rated current of each phase is 20 A.

- **Impedance bypass function**

Impedance elements can be shorted if they are not necessary such as in harmonic tests.

- **Designed specifically for JIS and IEC standards**

The product contains impedances required for harmonic and flicker testing of devices connected to power distribution systems.

- **Reduction of effects caused by wiring impedance between AC power supplies and LIN-JF**

The sensing functions that are equipped in the PCR-LE and PCR-LE2 series AC power supplies can be used to reduce the effects of wiring impedance.

- **Communication function**

The available contact signal input terminal can be used to remotely control impedance selection. Remote control using USB is also available.

# Impedance Construction

This product's impedance consists of resistance, inductance, and short-circuit switch for each phase. The N phase impedance has a switch for selecting between resistance and inductance.

The following tables contain the defined resistance and inductance values for the U, V, W, and N phases. The impedances made up of these components are generally referred to as Z1, Z2, and Z3.

## LIN1020JF

Phase	Z1	Z2	Z3	BYPASS
L(U)	$0.19 \Omega + 0.23 \text{ mH}$	$0.19 \Omega + 0.23 \text{ mH}$	$0.24 \Omega + jn 0.15 \Omega$	Impedance element shorted
N	$0.21 \Omega + 0.14 \text{ mH}$	$0.19 \Omega + 0.23 \text{ mH}$	$0.16 \Omega + jn 0.1 \Omega$	

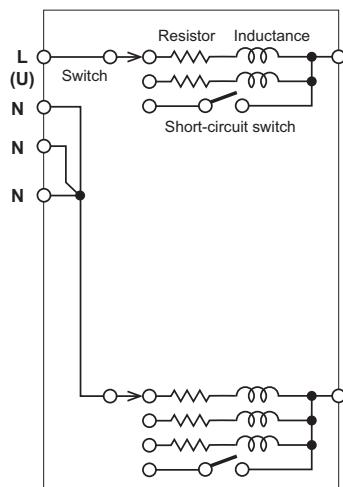

## LIN3020JF

Phase	Z1	Z2	Z3	BYPASS
U	$0.19 \Omega + 0.23 \text{ mH}$	$0.19 \Omega + 0.23 \text{ mH}$	$0.24 \Omega + jn 0.15 \Omega$	Impedance element shorted
V	$0.19 \Omega + 0.23 \text{ mH}$	$0.19 \Omega + 0.23 \text{ mH}$	$0.24 \Omega + jn 0.15 \Omega$	
W	$0.19 \Omega + 0.23 \text{ mH}$	$0.19 \Omega + 0.23 \text{ mH}$	$0.24 \Omega + jn 0.15 \Omega$	
N	$0.21 \Omega + 0.14 \text{ mH}$	$0.19 \Omega + 0.23 \text{ mH}$	$0.16 \Omega + jn 0.1 \Omega$	

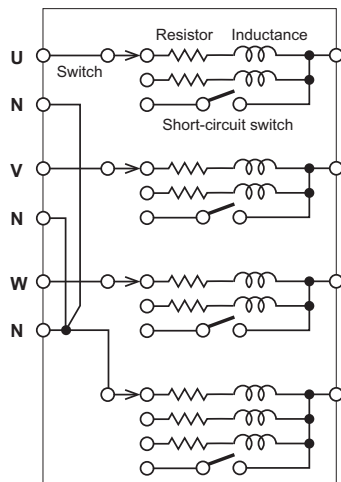

### OP01-LIN1020JF

Phase	Z1	Z2	Z3	BYPASS
V	$0.19 \Omega + 0.23 \text{ mH}$	$0.19 \Omega + 0.23 \text{ mH}$	$0.24 \Omega + jn 0.15 \Omega$	Impedance element shorted
W	$0.19 \Omega + 0.23 \text{ mH}$	$0.19 \Omega + 0.23 \text{ mH}$	$0.24 \Omega + jn 0.15 \Omega$	

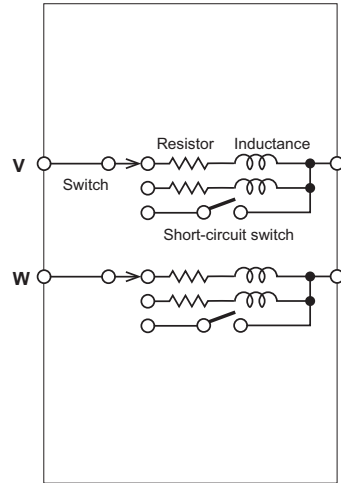

## Overview of the Test System

The test system can be divided into the following two categories depending on the EUT.

- A test system for devices that connect to an AC power line and consume its power. General devices are applicable for this test system. This manual refers to this test system as a device test system.
- A test system for devices that connect to an AC power line and consume its power or regenerate power to the line. Power conditioners and the like are applicable for this test system. This manual refers to this test system as a grid-connected device test system.

This product is a component of the above-mentioned test systems and is referred to as the reference impedance or line impedance. The test systems have single-phase two-wire, single-phase three-wire, three-phase three-wire, and three-phase four-wire circuits for the different wiring systems.

## Device test system

This section provides a typical example of a device test system using this product.

### Single-phase 2 kVA: JIS harmonic test, IEC flicker test

Component	Model and function
AC power supply	PCR2000LE
Impedance	LIN1020JF The use of impedance is optional for JIS C61000-3-2(2005) and later. The BYPASS function is used on the LIN1020JF. Z1: JIS 100 V harmonic test Z2: JIS 200 V harmonic test Z3: IEC flicker test
Power analyzer	KHA3000

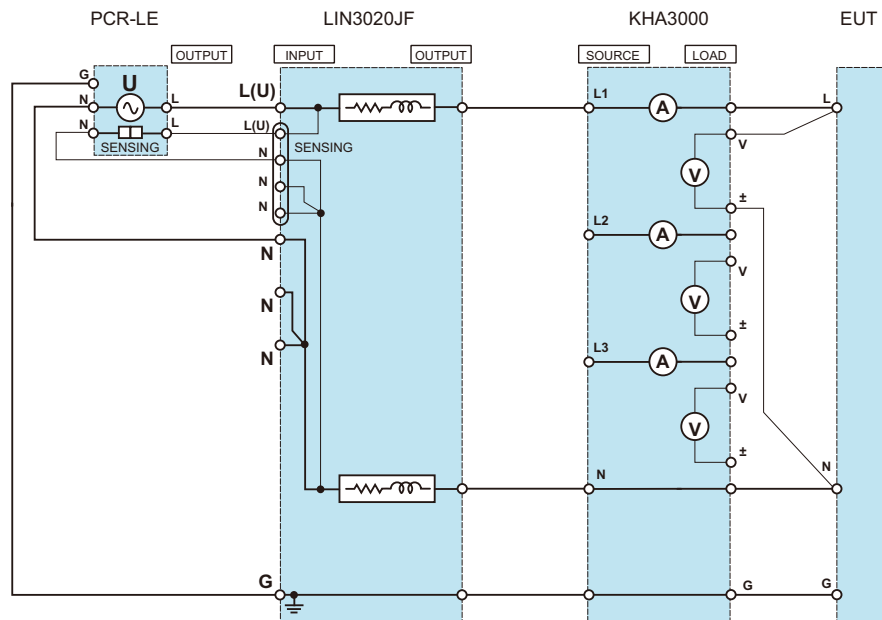

### Single-phase 2 kVA, three-phase 6 kVA: JIS harmonic test, IEC flicker test

Component	Model and function
AC power supply	Three PCR2000LEs
Impedance	LIN3020JF or a combination of a LIN1020JF and OP01-LIN1020JF The use of impedance is optional for JIS C61000-3-2(2005) and later. The BYPASS function is used on the LIN3020JF or the combination of a LIN1020JF and OP01-LIN1020JF. Z1: JIS 100 V harmonic test Z2: JIS 200 V harmonic test Z3: IEC flicker test
Power analyzer	KHA3000

■ A combination of a LIN1020JF and OP01-LIN1020JF

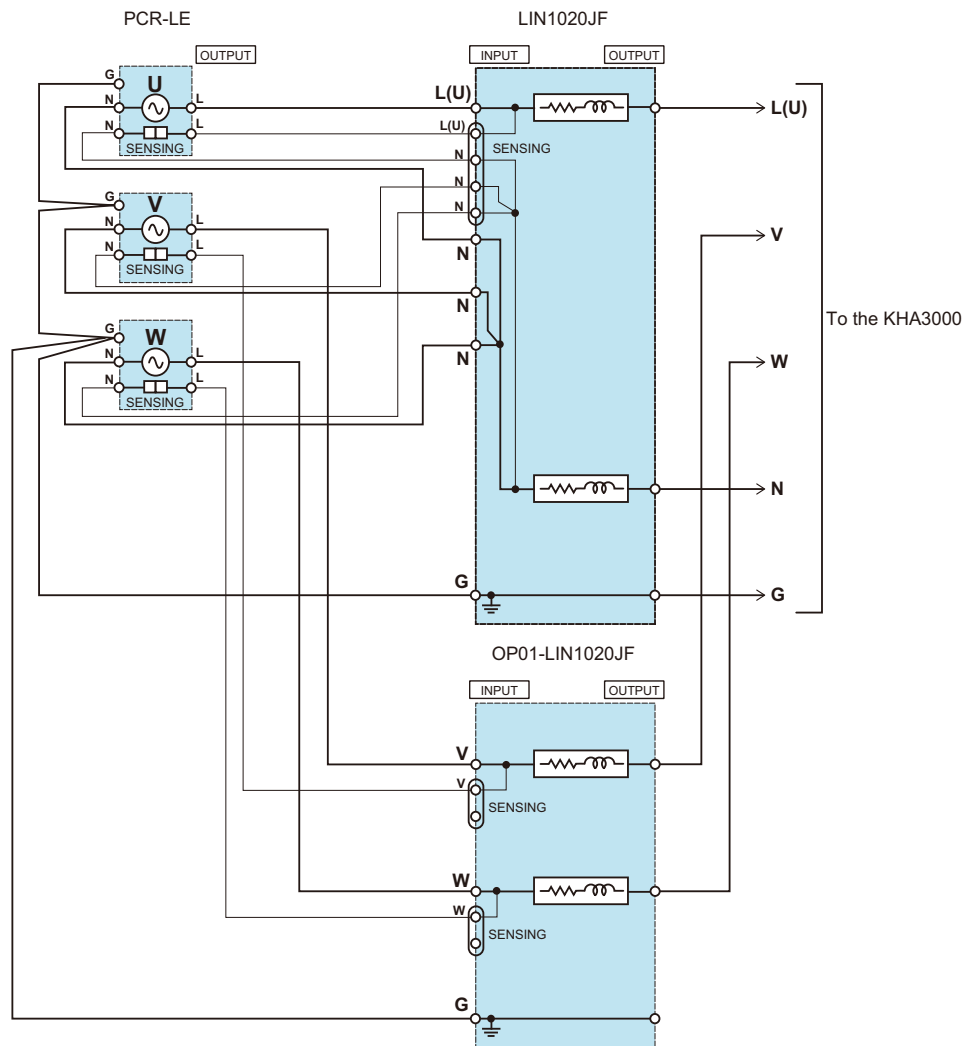

■ LIN3020JF

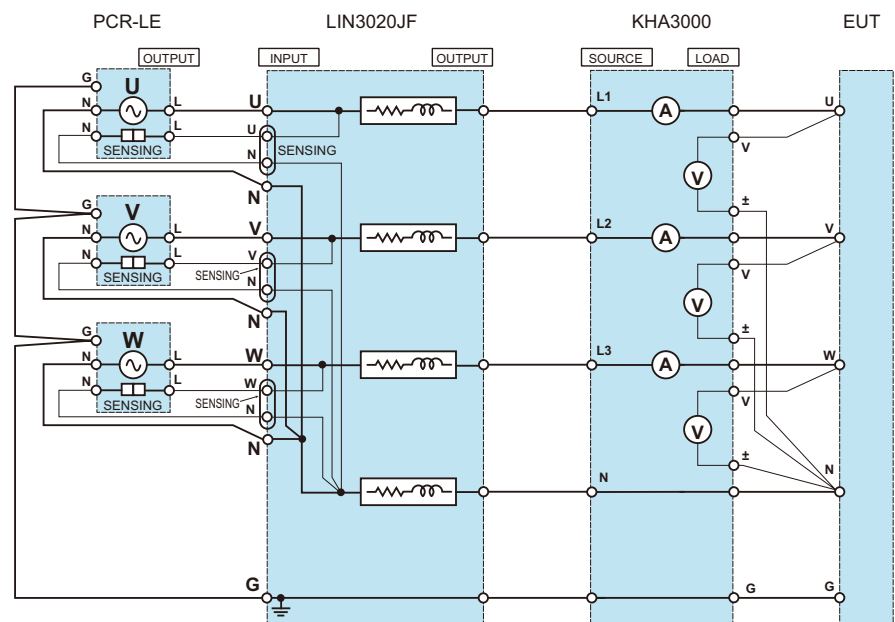

## Grid-connected device test system

This section provides a typical example of a grid-connected device test system using this product.

### Three-phase 6 kVA: JIS/JET grid-interconnection test

Component	Model and function
AC power supply	Three PCR2000LEs
Impedance	LIN3020JF
Power analyzer	KHA3000
LCR load	—
Motor load	—
DC power supply	—

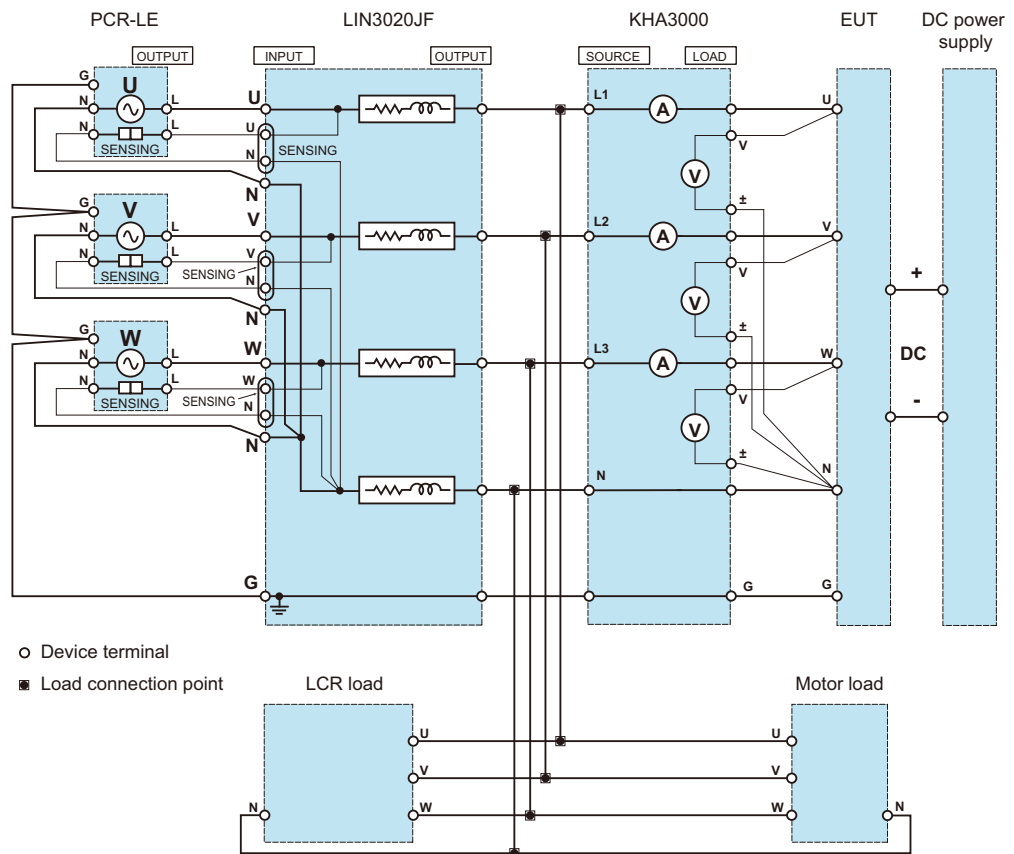

# 2 Description of Parts

See p.63, p.69

This chapter explains the details of the product's parts. The descriptions of the terminals of the system components, namely the PCR-LE, PCR-LE2, and KHA3000, are provided in the appendixes.

## LIN1020JF

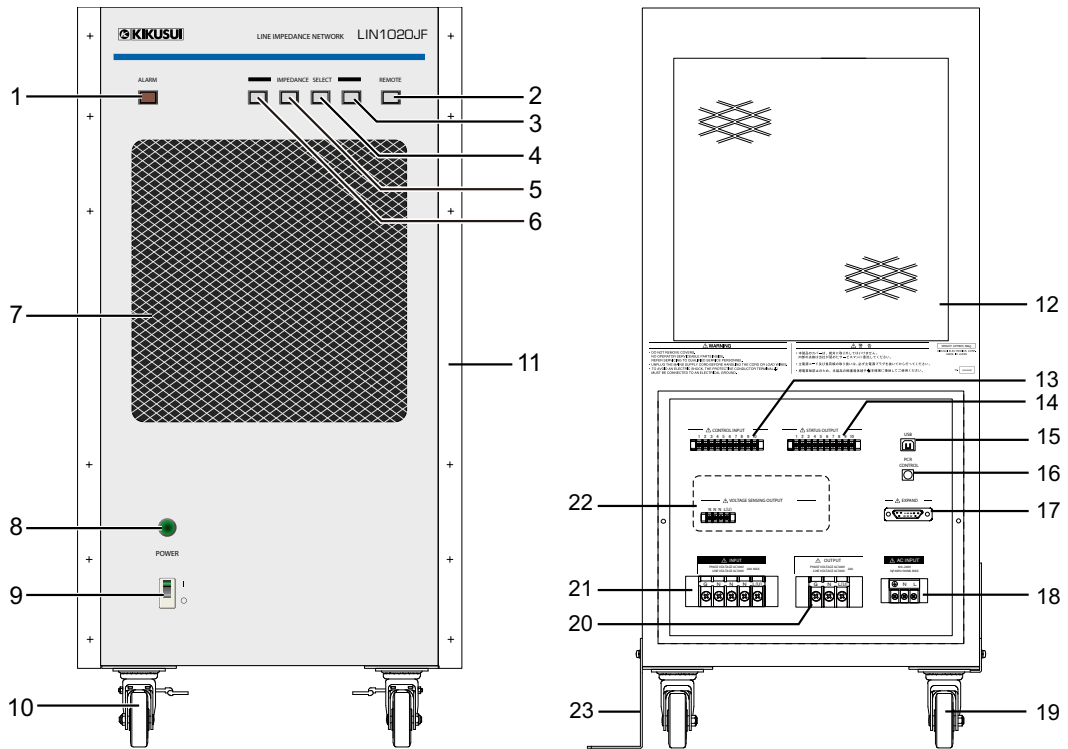

No.	Name	Function
1	ALARM indicator	Lights when the internal overheat alarm occurs
2	REMOTE	Remote control switch (illuminated type)
3	BYPASS	Impedance bypass switch (illuminated type)
4	Z3	Z3 impedance switch (illuminated type)
5	Z2	Z2 impedance switch (illuminated type)
6	Z1	Z1 impedance switch (illuminated type)
7	Air inlet	Air inlet for internal cooling
8	Power indicator	Lights when the POWER switch is turned on
9	POWER switch	Power switch for the control power supply
10	Caster	Caster with a lock
11	Rack mount bracket	L-shaped bracket for mounting the product on a rack
12	Air outlet	Air outlet for internal cooling
13	CONTROL INPUT	Contact signal control input terminal
14	STATUS OUTPUT	Status output terminal
15	USB	Remote control USB port
16	PCR CONTROL	AC power supply control terminal
17	EXPAND	Expansion terminal (for controlling the OP01-LIN1020JF)
18	AC INPUT	Control power supply input terminal
19	Caster	Caster (without a lock)
20	OUTPUT	Output terminal block: G • N • N • N • L(U)
21	INPUT	Input terminal block: G • N • L(U)
22	VOLTAGE SENSING OUTPUT	Sensing terminal
23	Base hold angle	L-shaped bracket for fixing the product to the installation location

# LIN3020JF

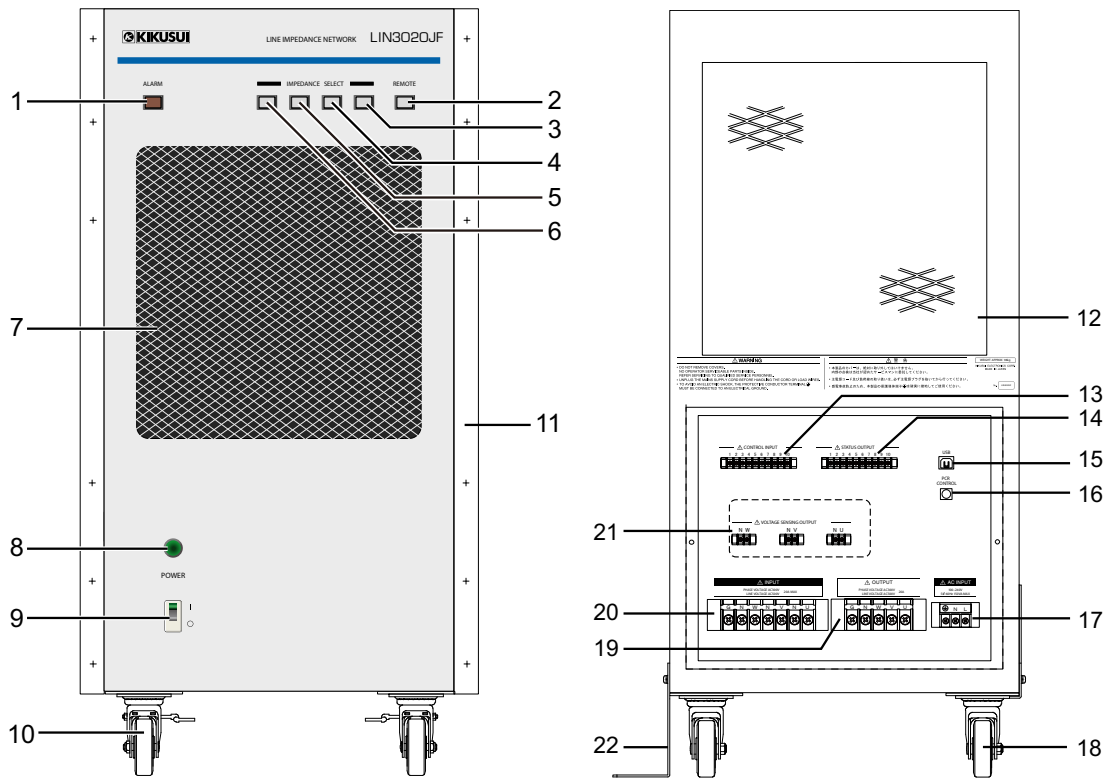

No.	Name	Function
1	ALARM indicator	Lights when the internal overheat alarm occurs
2	REMOTE	Remote control switch (illuminated type)
3	BYPASS	Impedance bypass switch (illuminated type)
4	Z3	Z3 impedance switch (illuminated type)
5	Z2	Z2 impedance switch (illuminated type)
6	Z1	Z1 impedance switch (illuminated type)
7	Air inlet	Air inlet for internal cooling
8	Power indicator	Lights when the POWER switch is turned on
9	POWER switch	Power switch for the control power supply
10	Caster	Caster with a lock
11	Rack mount bracket	L-shaped bracket for mounting the product on a rack
12	Air outlet	Air outlet for internal cooling
13	CONTROL INPUT	Contact signal control input terminal
14	STATUS OUTPUT	Status output terminal
15	USB	Remote control USB port
16	PCR CONTROL	AC power supply control terminal
17	AC INPUT	Control power supply input terminal
18	Caster	Caster (without a lock)
19	OUTPUT	Output terminal block: G • N • W • N • V • N • U
20	INPUT	Input terminal block: G • N • W • V • U
21	VOLTAGE SENSING OUTPUT	Sensing terminal
22	Base hold angle	L-shaped bracket for fixing the product to the installation location



## OP01-LIN1020JF

- The OP01-LIN1020JF is used in combination with the LIN1020JF. It cannot be used by itself.

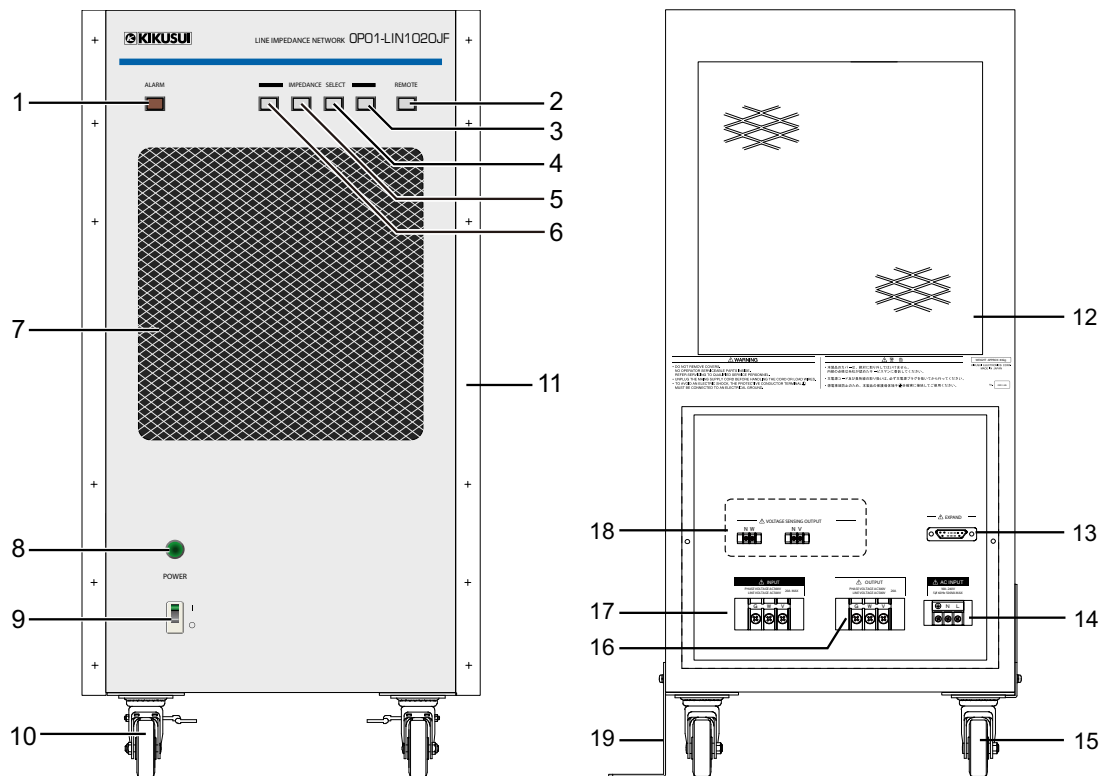

No.	Name	Function
1	ALARM indicator	Lights when the internal overheat alarm occurs
2	REMOTE indicator	Lights when remote control is selected
3	BYPASS indicator	Lights when impedance bypass is selected
4	Z3 indicator	Lights when the Z3 impedance is selected
5	Z2 indicator	Lights when the Z2 impedance is selected
6	Z1 indicator	Lights when the Z1 impedance is selected
7	Air inlet	Air inlet for internal cooling
8	Power indicator	Lights when the POWER switch is turned on
9	POWER switch	Power switch for the control power supply
10	Caster	Caster with a lock
11	Rack mount bracket	L-shaped bracket for mounting the product on a rack
12	Air outlet	Air outlet for internal cooling
13	EXPAND	Expansion terminal (for controlling the OP01-LIN1020JF)
14	AC INPUT	Control power supply input terminal
15	Caster	Caster (without a lock)
16	OUTPUT	Output terminal block: G • W • V
17	INPUT	Input terminal block: G • W • V
18	VOLTAGE SENSING OUTPUT	Sensing terminal
19	Base hold angle	L-shaped bracket for fixing the product to the installation location

## INPUT and OUTPUT terminals

The INPUT and OUTPUT terminals are impedance input and output terminals. There is a separate terminal for each phase: U, V, W, and N. The input and output terminals are used according to the test circuit system. The size of the terminal block screws is M6. The nominal cross-sectional area of wires is 22 mm<sup>2</sup> minimum.

## VOLTAGE SENSING OUTPUT terminal

The VOLTAGE SENSING OUTPUT terminal is connected to the sensing terminal of the PCR-LE or PCR-LE2. There is a separate terminal for each phase: U, V, W, and N. Each terminal is used according to the wiring system.

The figure shows an example of the LIN3020JF. When the sensing function is used, the output terminal of the AC power supply appears as if it is the resistor connection point of the product. As such, the impedance between the output terminal of the AC power supply and the resistor connection point of the product can be assumed to be zero. This reduces the effects of wiring impedance and increases the degree of freedom in the wiring length when integrating the impedance into the test system.

The size of the terminal block screws is M3. The nominal cross-sectional area of wires is 0.75 mm<sup>2</sup> (AWG18) minimum.

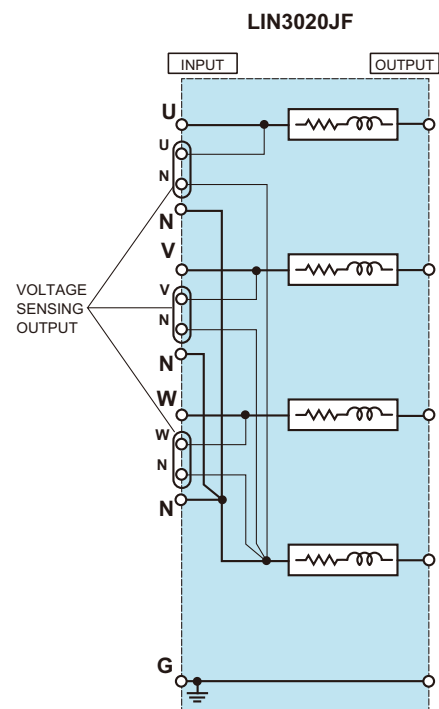

## AC INPUT (control power supply input terminal)



**WARNING**

**Risk of electric shock.**

- This product conforms to IEC Safety Class I (equipment that has a protective conductor terminal). Be sure to earth ground the product to prevent electric shock.
- Connect the protective conductor terminal to earth ground.



**CAUTION**

- If the voltage distortion of the AC power line is large, the product may malfunction. The product cannot be connected to a generator or the like.
- Use the AC line for the input power supply. Do not supply power from the output of the AC power supplies that are connected to this product.

The product can receive a nominal line voltage in the range of 100 Vac to 240 Vac at 50 Hz or 60 Hz. The size of the terminal block screws is M4.

## PCR CONTROL terminal LIN1020JF LIN3020JF

The PCR CONTROL terminal is available on the LIN1020JF and LIN3020JF. It is a terminal for controlling the AC power supplies. A signal is transmitted when the overheat protection of this product is activated and turns off the AC power supply output. Use the supplied exclusive cable for connecting this terminal.

- CAUTION** • The PCR CONTROL terminal must be connected properly to the AC power supplies for the AC power supply output to be turned off when the overheat protection of this product is activated (ALARM indicator turns on).

## EXPAND terminal LIN1020JF OP01-LIN1020JF

The EXPAND terminal is available on the LIN1020JF and OP01-LIN1020JF. Use the OP01 control cable to connect between the terminals. When the LIN1020JF and OP01-LIN1020JF are used in combination, a single-phase three-wire test circuit, three-phase three-wire test circuit, and three-phase four-wire test circuit can be constructed. The OP01 control cable is supplied with the OP01-LIN1020JF.

## CONTROL INPUT and STATUS OUTPUT terminals

LIN1020JF LIN3020JF

See p.53

The CONTROL INPUT and STATUS OUTPUT terminals are available on the LIN1020JF and LIN3020JF. You can use the CONTROL INPUT terminal to control the product's impedance externally. You can use the STATUS OUTPUT terminal to check the product status.

The size of the terminal block screws is M3. The nominal cross-sectional area of wires is 0.75 mm<sup>2</sup> (AWG18) minimum. The following figure shows the internal equivalent circuits of both terminals.

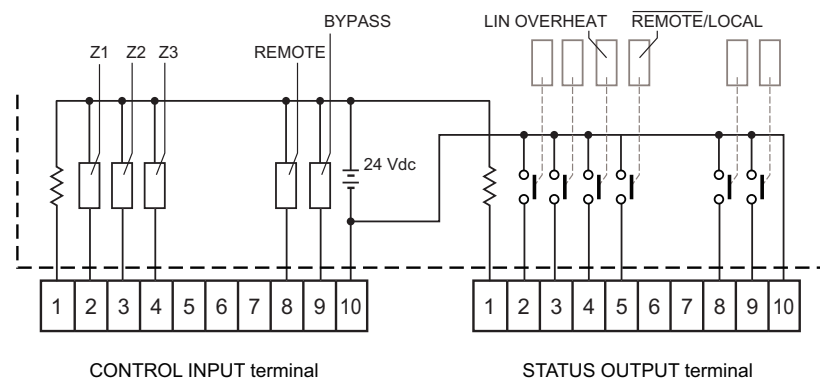

## USB port LIN1020JF LIN3020JF

See p.55

The USB port is available on the LIN1020JF and LIN3020JF. You can use the USB port to remotely control the product. To do so, connect the USB port to a USB port on your PC.

# 3 Wiring the Test System

This chapter describes how to wire the product to the test system.



- **Risk of electric shock. For the devices that will be used in the test circuit, be sure to remove the power cable from the AC power line, turn off the switchboard that the power cable is connected to, and turn off the POWER switch.**

## Removing the Terminal Cover

Remove the terminal cover, and then connect the terminals. After connecting the terminals, be sure to attach the terminal cover back on using the left and right screws.

- 1 Check that the POWER switch is turned off.**  
Check that the power indicator on the front panel is off.
- 2 Unfasten the screws from the terminal cover attached to the lower part of the rear panel of this product.**  
Leave the cover open until all wiring is finished.

## Connecting the Control Power Cable

- 1 Connect the supplied control power cable to the AC INPUT terminal on the rear panel.**  
Connect the power wires from the power cable to the L and N terminals and the ground wire to the protective conductor terminal.
- 2 Connect the control power cable plug to a properly grounded outlet.**  
The product can receive a nominal line voltage in the range of 100 Vac to 240 Vac at 50 Hz or 60 Hz.

# Wiring the Test Circuit

 p.25, p.37

The details of wiring the test circuits are provided in chapter 4 for the LIN1020JF and OP01-LIN1020JF and chapter 5 for the LIN3020JF. The test circuits are grouped by the number of AC power supplies (PCR-LEs or PCR-LE2s), and the different input power supply systems (single-phase two-wire, single-phase three-wire, three-phase three-wire, and three-phase four-wire) of the EUT are described. The input power supply systems of the EUT will be denoted as 1P2W for single-phase two-wire, 1P3W for single-phase three-wire, 3P3W for three-phase three-wire, and 3P4W for three-phase four-wire.

 p.15, p.63,  
p.69

The wiring diagrams use schematic symbols to make the entire wiring easier to understand. For details on how to connect the actual terminals, see the description of each part, the appendixes, or the operation manual of the relevant product.

## NOTE

- The G terminal in the wiring diagrams is not the protective conductor terminal. Connecting to the G terminal will not ground the device.

## Nominal cross-sectional area of wires

Circuit	Nominal cross-sectional area
Primary current circuit	22 mm <sup>2</sup>
Sensing	0.75 mm <sup>2</sup>
KHA3000 voltage measurement	0.75 mm <sup>2</sup>

Be sure to observe the nominal cross-sectional area. This is especially important in the primary current circuit to ensure proper impedance characteristics.

## Parts to have ready

Please prepare your own wires and crimping terminals for connecting between the devices of the test circuit. Select wires with sufficient withstanding voltage for the test voltage that will be used. Using wires with a rated voltage of 600 V or higher will ensure safety up to the maximum output voltage of the AC power supplies.

We recommend that you use terminals, wires, and the like with appropriate safety (e.g. UL) certifications.

## AC power supplies that can be used

The LIN-JF can be used with PCR-LE and PCR-LE2 AC power supplies.

Because the sensing functions that are equipped in the PCR-LE and PCR-LE2 series are used to reduce the effects of wiring impedance, conventional power supplies such as the PCR-L and PCR-LA series or AC power supplies made by other manufacturers cannot be used.

## CAUTION

- If the sensing cables become disconnected or the polarities are incorrect, an overvoltage will be generated in the output of the AC power supplies. This will cause the protection function of the AC power supplies to be activated and will turn off the output.

# Connecting the Control Terminals

## Connecting the PCR CONTROL terminal

LIN1020JF

LIN3020JF

The PCR CONTROL terminal is for controlling the AC power supplies. A signal is transmitted when the overheat protection of this product is activated and turns off the AC power supply output. Use the supplied exclusive cable for connecting this terminal.

If you want to use this product with the DSI series dip simulator in the test system, connect the DSI series to the AC power supplies first, and connect this product last. For details, see the operation manual for the DSI series.

### Installing the supplied control boards into the AC power supplies



#### CAUTION

Do not touch the circuit board area of the control board. Static electricity may damage the circuit.

- 1** Check that the **POWER** switches of the AC power supplies are turned off (○).  
In addition, shut down the power supply from the switchboard.
- 2** Touch a grounded metal object (for example, the metal parts of the rear panel) to discharge any static electricity from your body.
- 3** Remove the screws that are holding the **SLOT 3** cover in place on the rear panel, and remove the cover from the panel.  
Keep the cover in a safe place. The screws that you removed will be used in step 6.

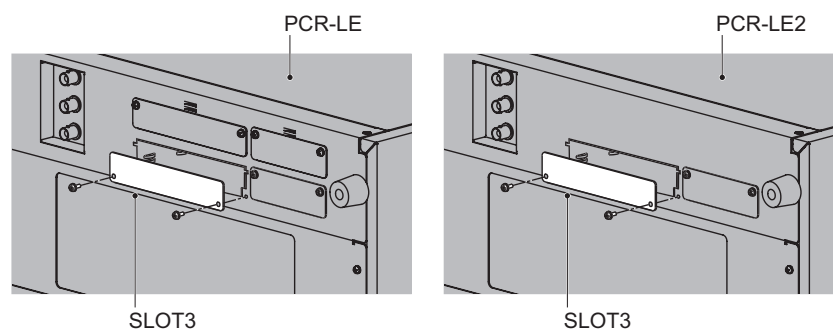

- 4** Flip the control board so that the side with the components is facing down, and hold the panel area of the board.
- 5** Insert the board all the way into the slot so that the connector is firmly inserted into the slot.
- 6** Use the screws that you removed earlier to fix the control board in place in the panel.

## Connecting the supplied control cable

**1** Check that the **POWER** switches of the LIN-JF and AC power supplies are turned off (○).

**2** Connect the control cable supplied with the LIN1020JF or LIN3020JF as shown in the following figure.

Connect one end of the cable to the connector of the control board that was installed in the AC power supply.

Connect the other end to the PCR CONTROL connector of the LIN1020JF or LIN3020JF.

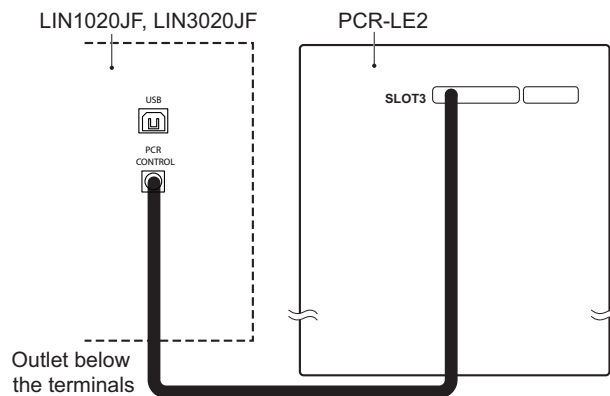
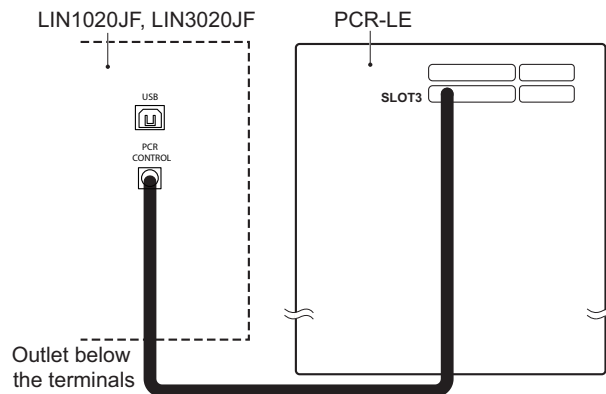

**3** Attach the terminal cover on the rear panel of the LIN-JF.

## Connecting the EXPAND Terminal

LIN1020JF

OP01-LIN1020JF

The EXPAND terminal is used when the LIN1020JF and OP01-LIN1020JF are used in combination to construct a single-phase three-wire test circuit, three-phase three-wire test circuit, or three-phase four-wire test circuit.

The OP01 control cable is supplied with the OP01-LIN1020JF.

### Connecting the supplied OP01 control cable

- 1 Check that the POWER switches of the LIN-JF and AC power supplies are turned off (○).
- 2 Connect the OP01 control cable as shown in the following figure. Connect one end of the cable to the EXPAND terminal of the LIN1020JF. Connect the other end of the cable to the EXPAND terminal of the OP01-LIN1020JF.

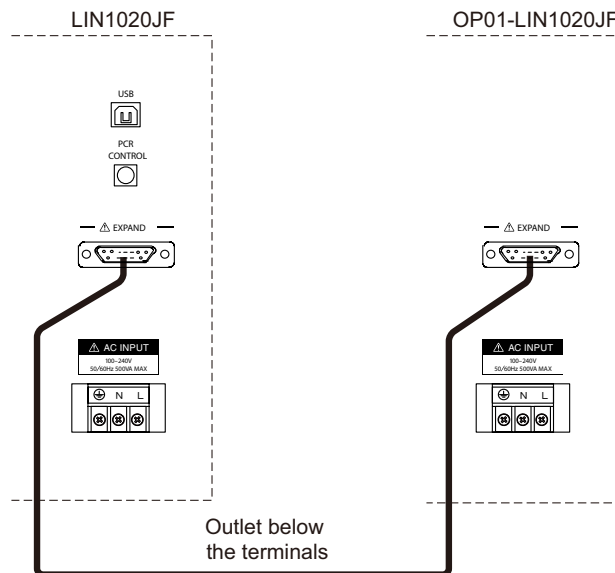

- 3 Attach the terminal cover on the rear panel of the LIN-JF.



# 4 Wiring the LIN1020JF

See p.21

This chapter provides wiring diagrams of test circuits that use the LIN1020JF and OP01-LIN1020JF.

For general information related to the wiring of test circuits, see chapter 3, "Wiring the Test Circuit".

The wiring diagrams of test circuits provided in the following pages contains the following types. Select the test circuit appropriate for your EUT.

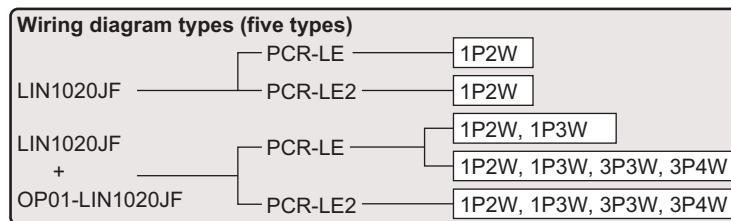

**WARNING**

**Risk of electric shock.**

- **Never connect the terminals on the INPUT or OUTPUT terminal blocks of the LIN-JF to the AC line. The internal circuit of the LIN-JF is not designed to be connected to the AC line.**

# LIN1020JF + one PCR-LE: single-phase

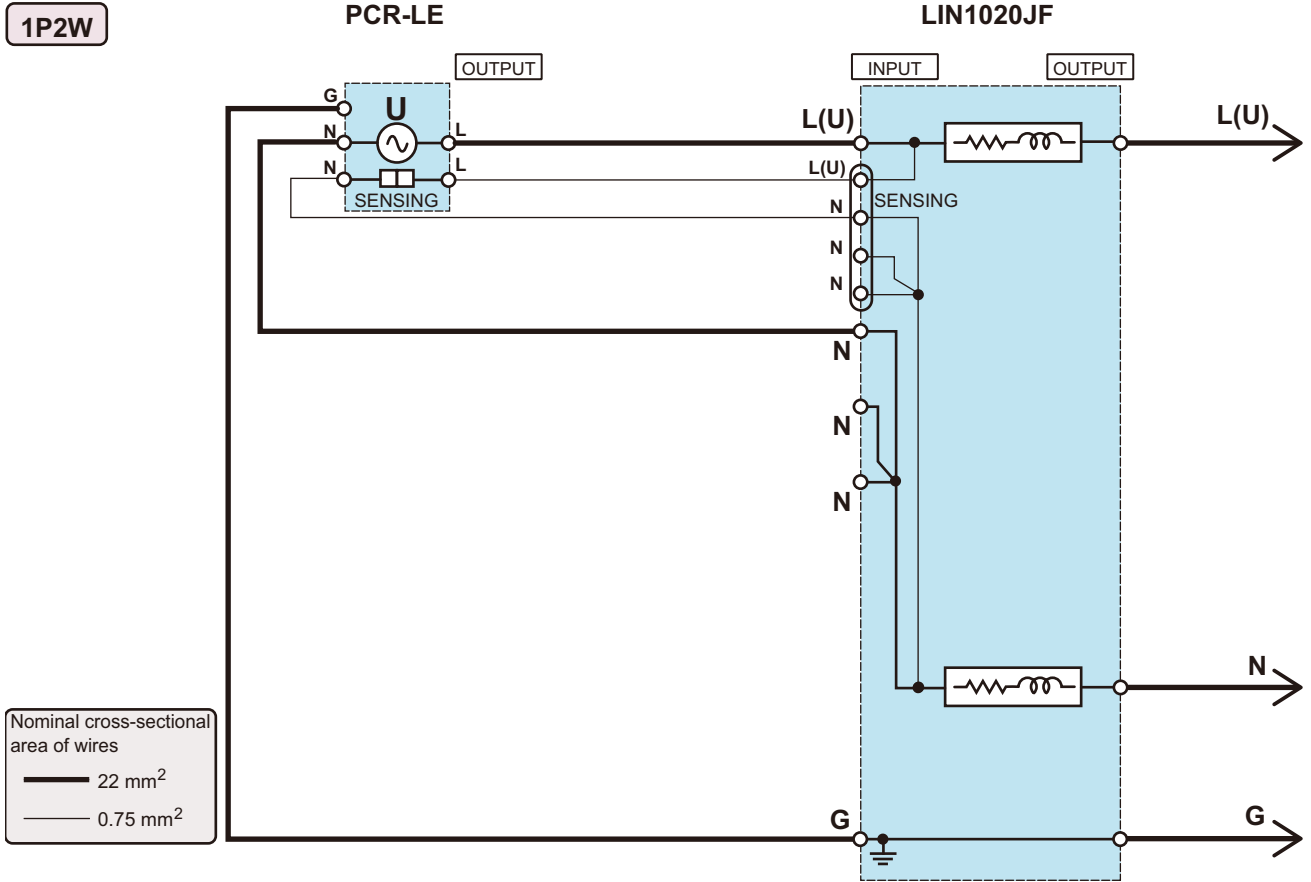

Nominal cross-sectional area of wires  
 — 22 mm<sup>2</sup>  
 — 0.75 mm<sup>2</sup>

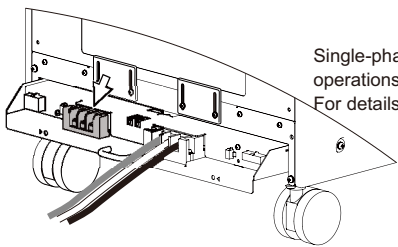

**PCR-LE**  
 Single-phase three-wire and three-phase operations require a PCR-LE option. For details, see the PCR-LE manual.

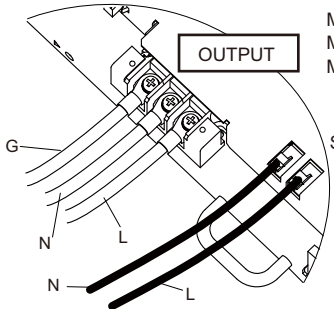

Terminal screw size  
 M4: PCR1000LE, PCR2000LE  
 M5: PCR3000LE, PCR4000LE  
 M6: PCR6000LE, PCR9000LE

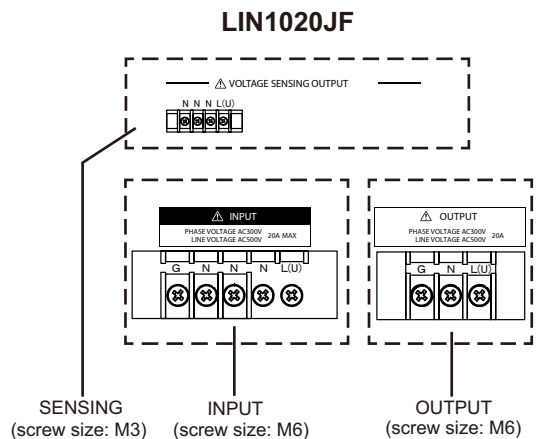

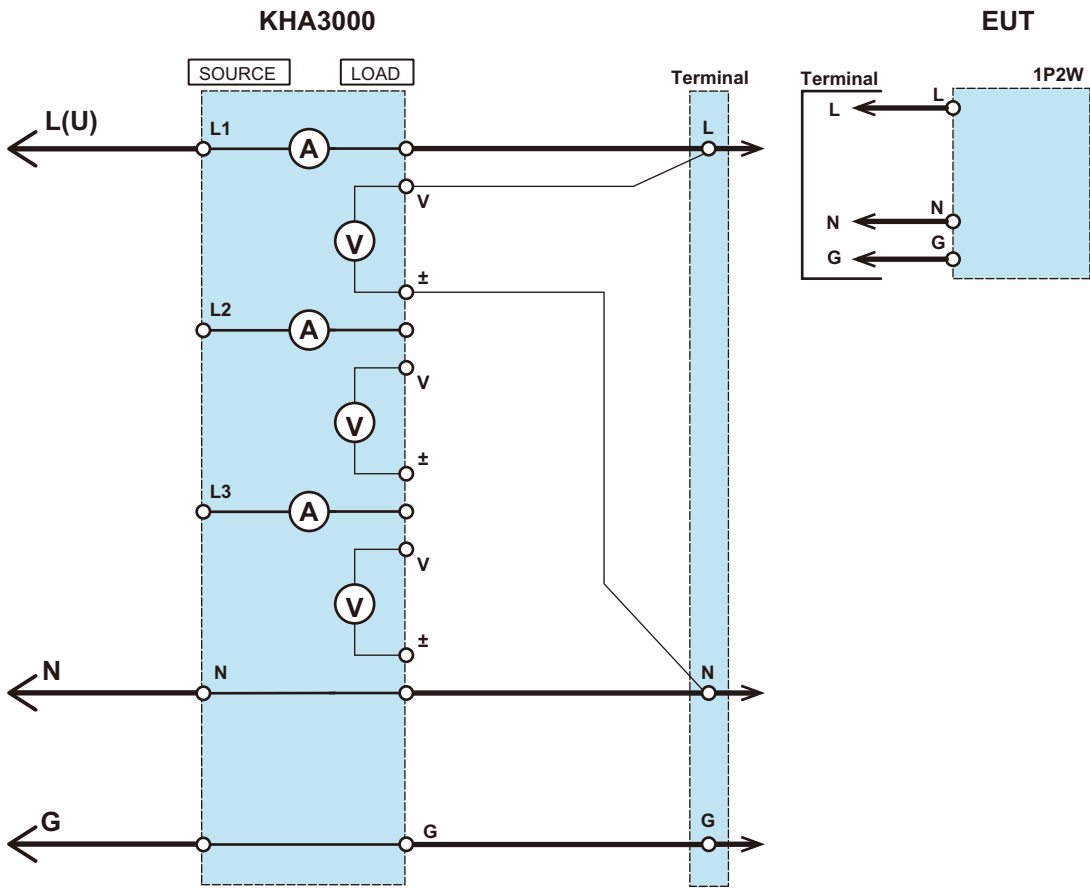

**KHA3000**

Voltage input terminals are L1, L2, and L3 inputs only.

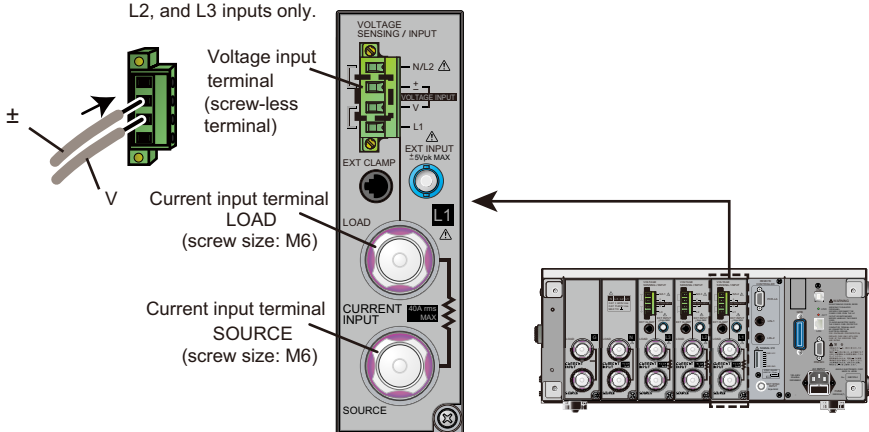

## LIN1020JF + one PCR-LE2: single-phase

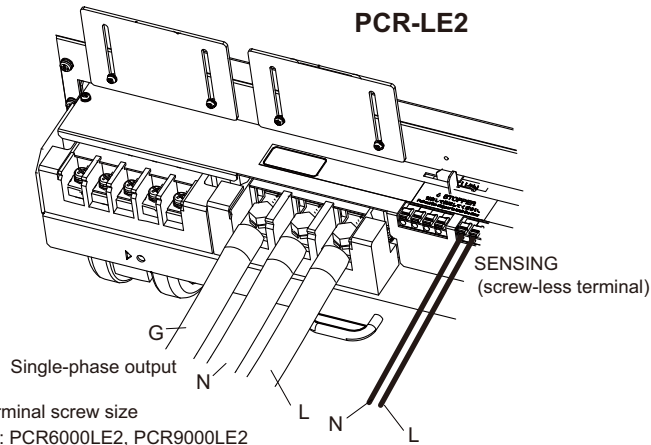
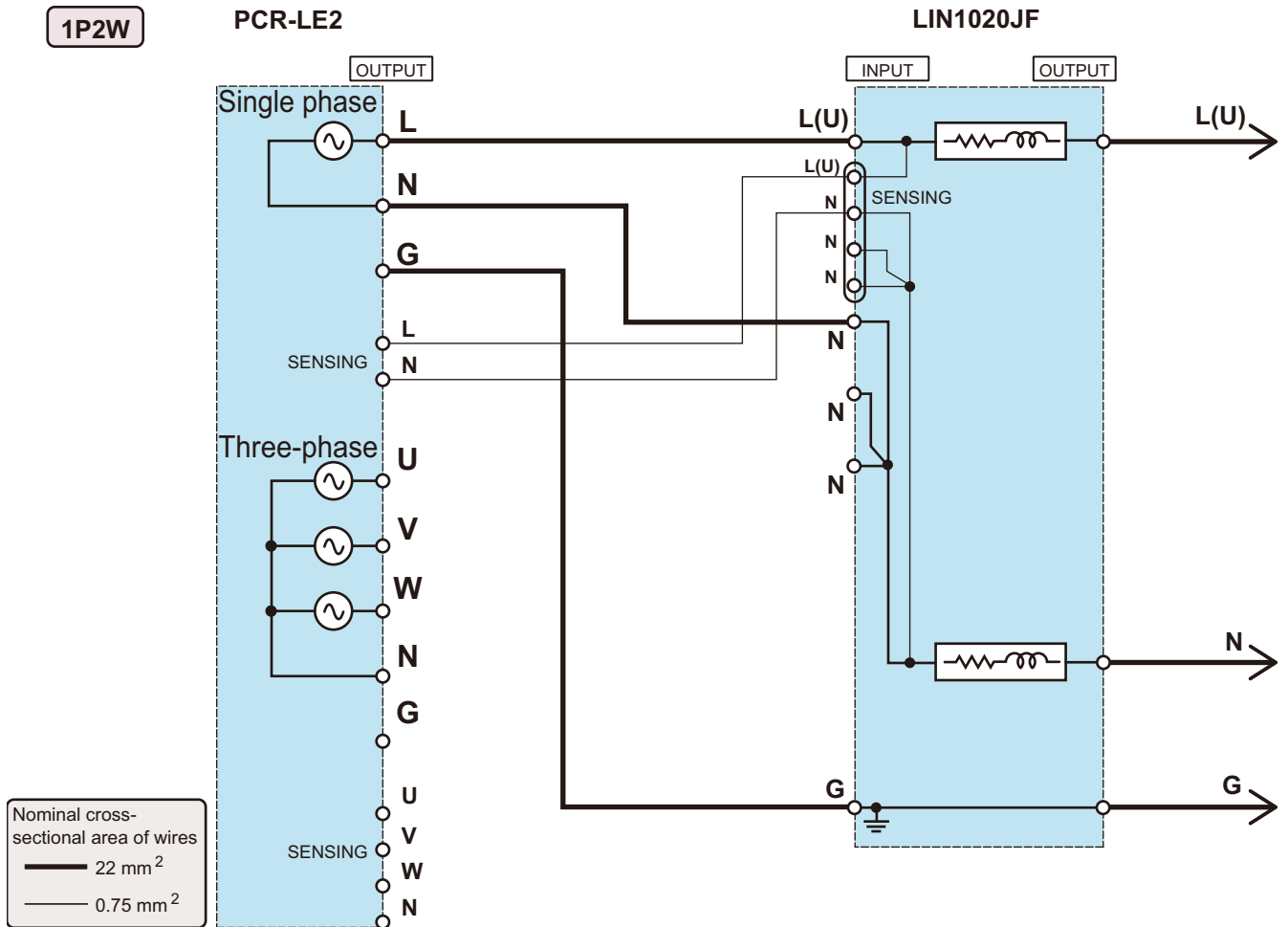

The output terminal shape on the PCR27000LE2 is different from what is shown above.  
 For details see the PCR-LE2 setup guide or user's manual.

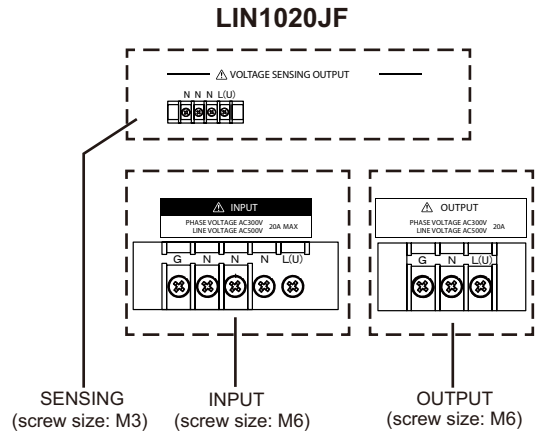

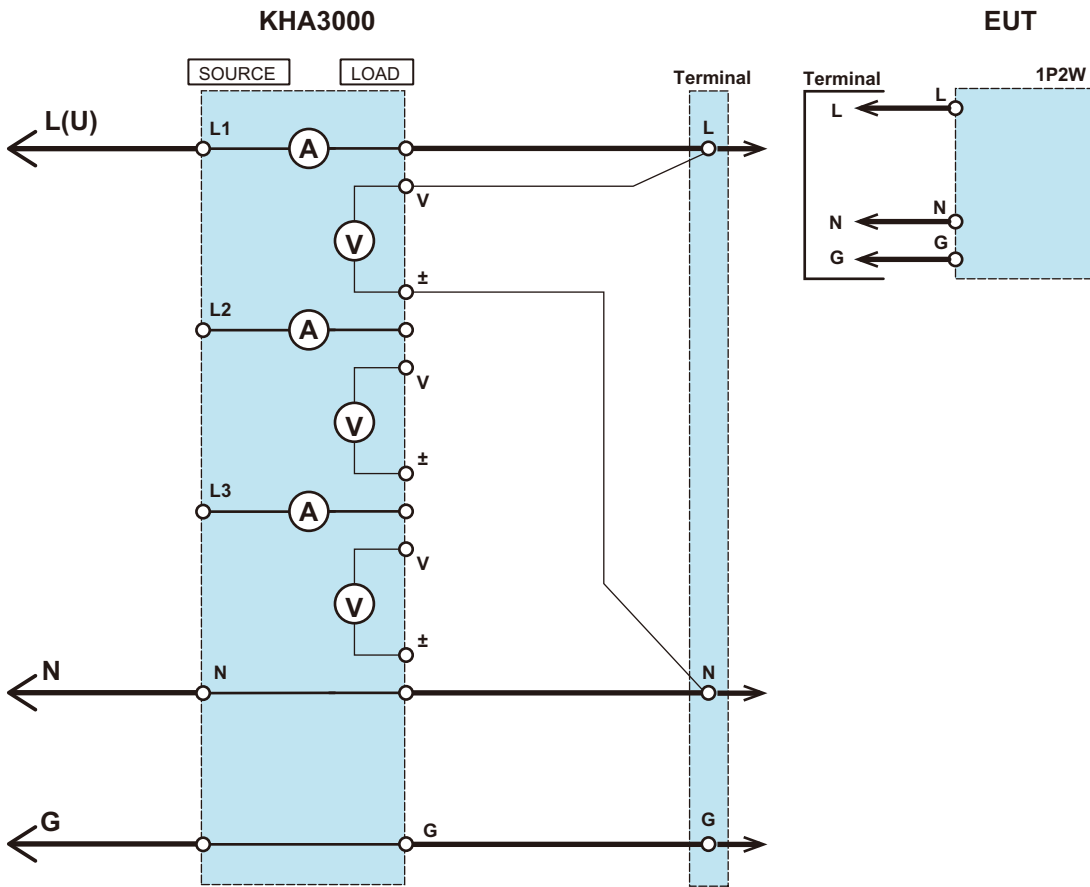

**KHA3000**

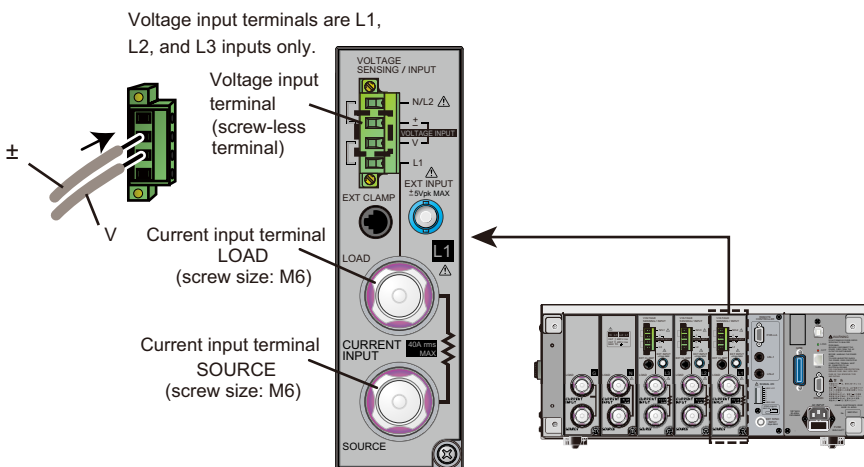

# Combination Wiring of LIN1020JF and OP01-LIN1020JF

## LIN1020JF + OP01 + two PCR-LEs: single-phase and single-phase three-wire

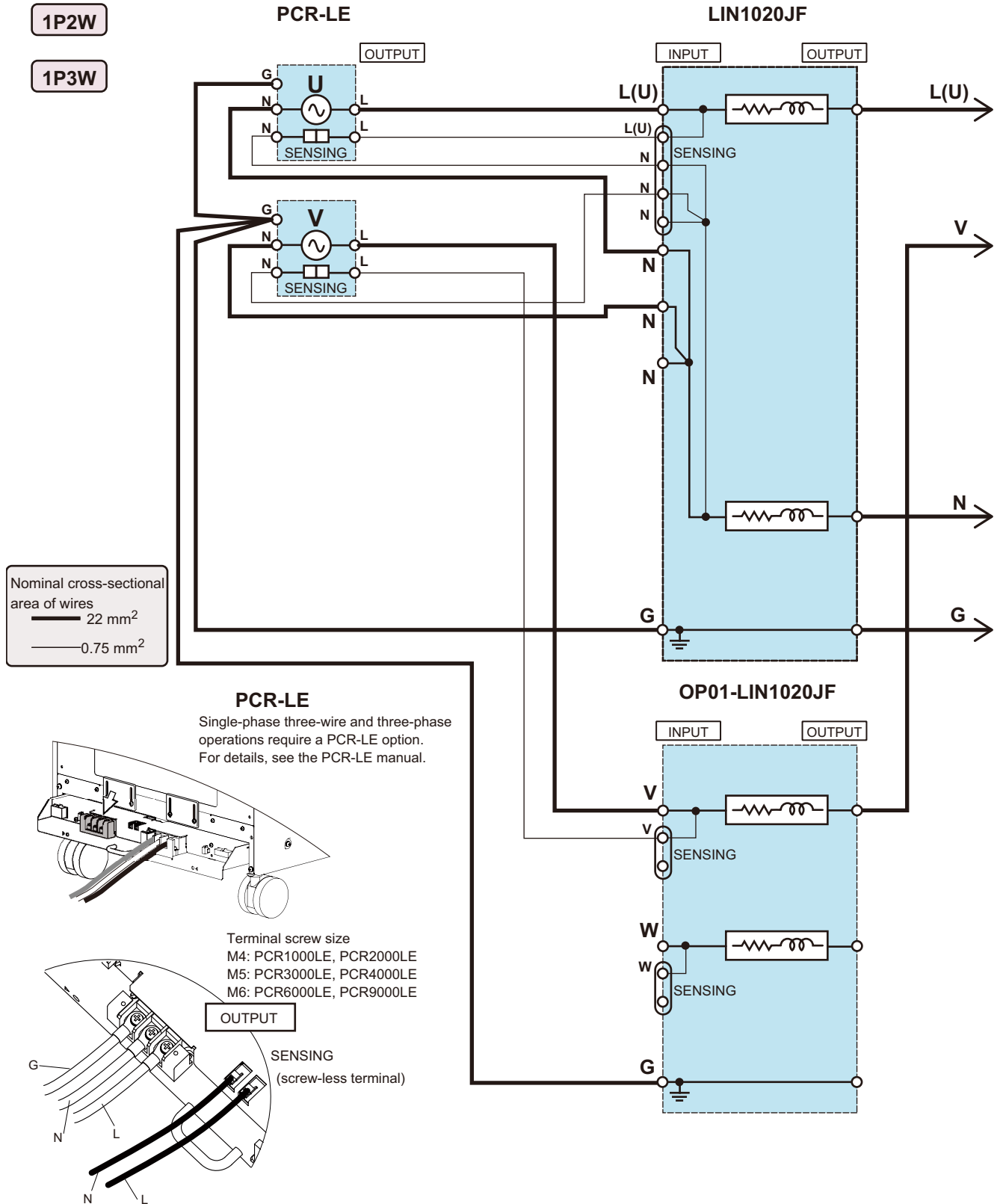

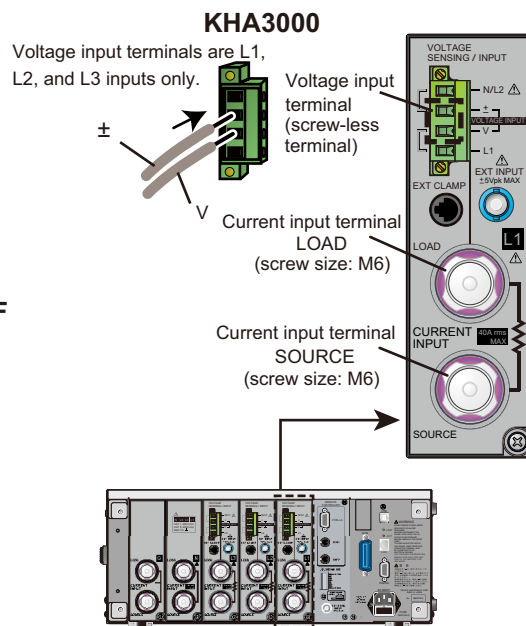
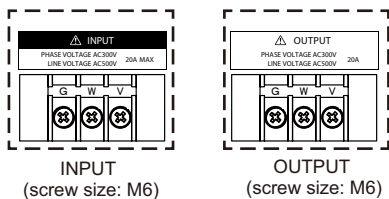
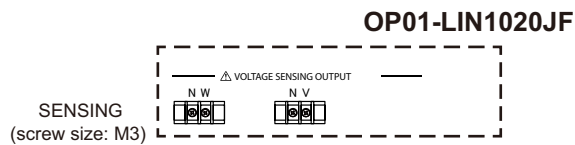
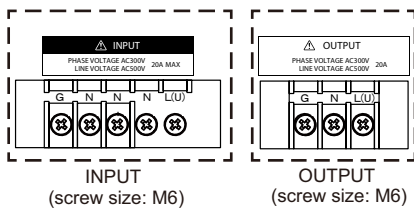
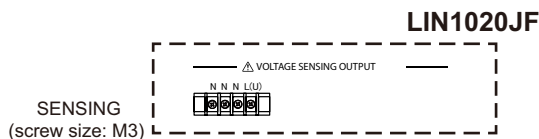
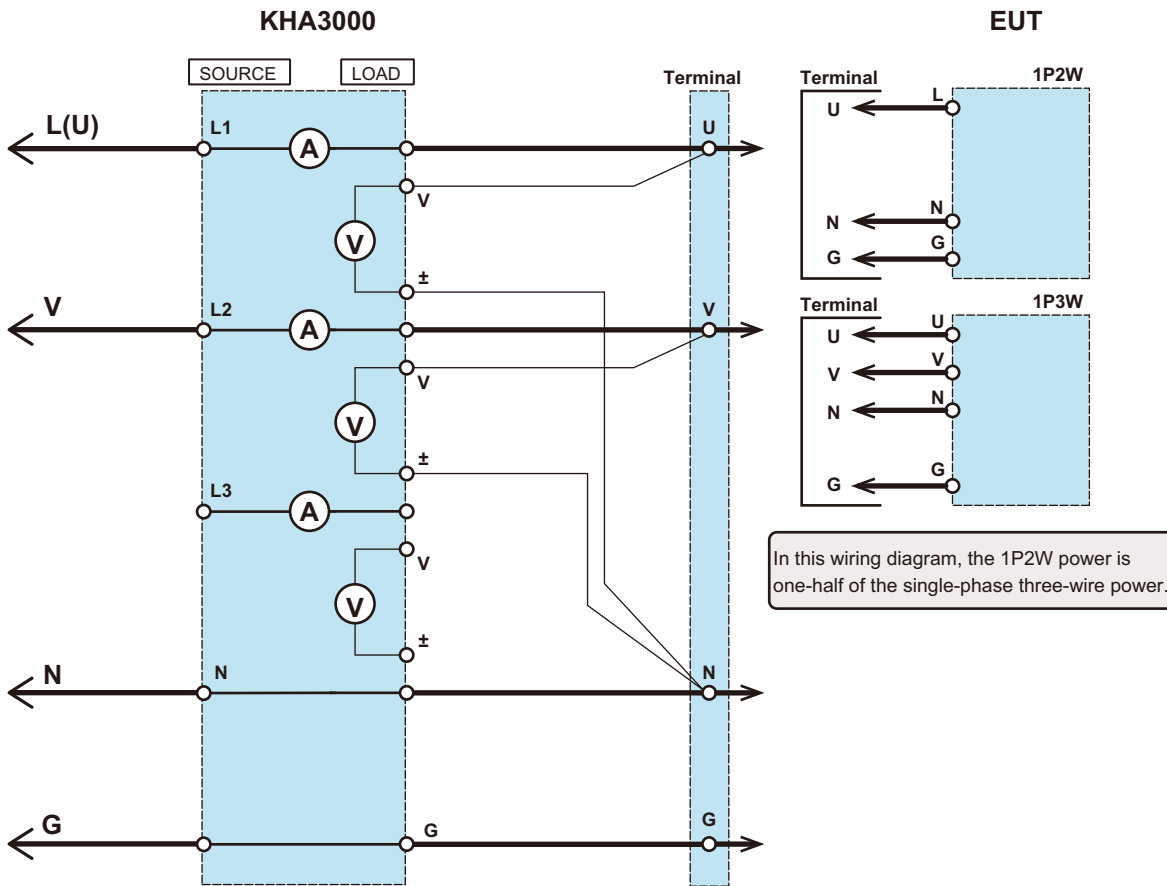

# LIN1020JF + OP01 + three PCR-LEs: single-phase and three-phase

- 1P2W
- 1P3W
- 3P3W
- 3P4W

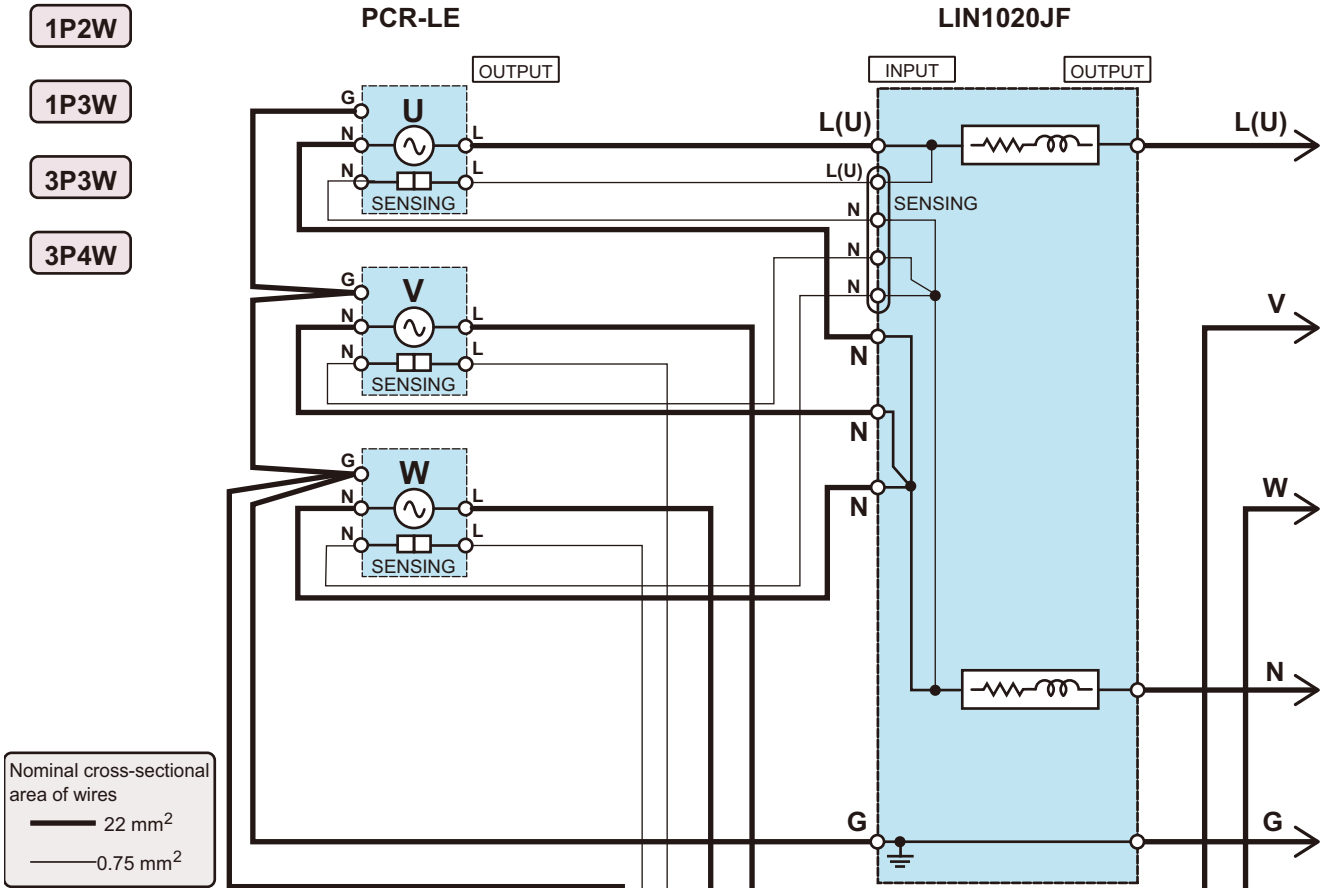

Nominal cross-sectional area of wires  
 — 22 mm<sup>2</sup>  
 — 0.75 mm<sup>2</sup>

### PCR-LE

Single-phase three-wire and three-phase operations require a PCR-LE option. For details, see the PCR-LE manual.

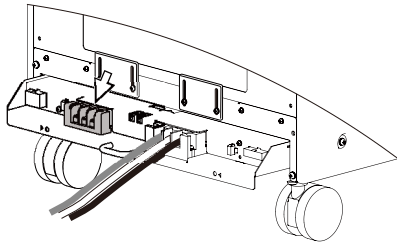

Terminal screw size  
 M4: PCR1000LE, PCR2000LE  
 M5: PCR3000LE, PCR4000LE  
 M6: PCR6000LE, PCR9000LE

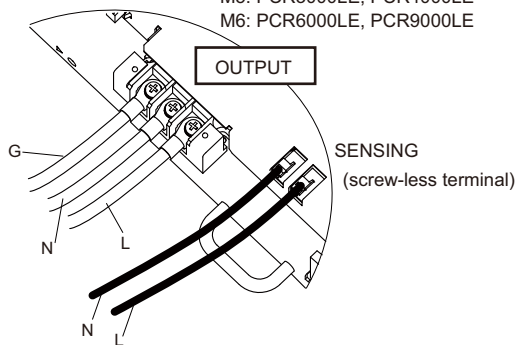

### OP01-LIN1020JF

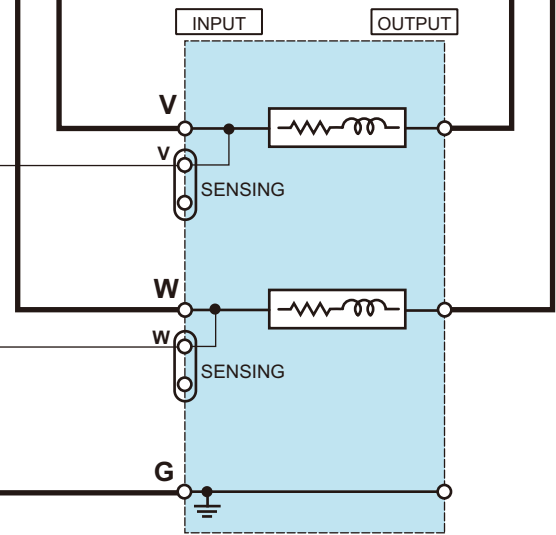



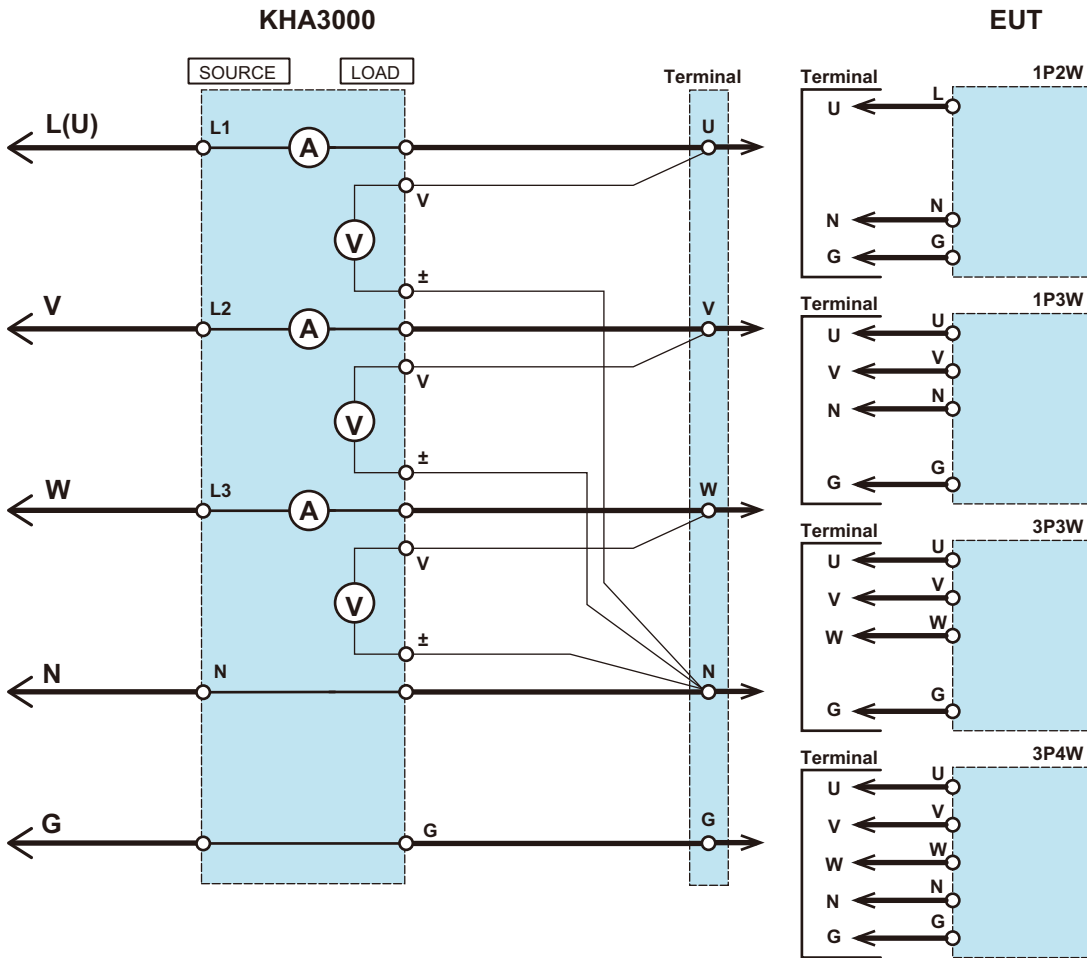

In this wiring diagram, the 1P2W power is one-third of the three-wire power. Likewise, the 1P3W power will be two-thirds.

**LIN1020JF**

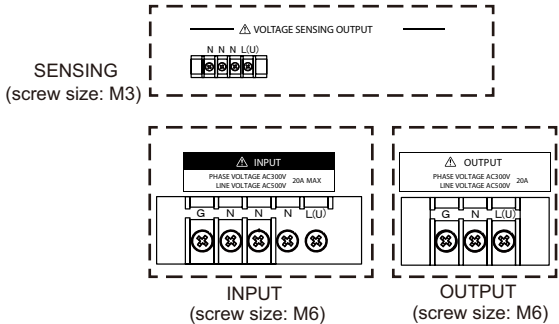

**OP01-LIN1020JF**

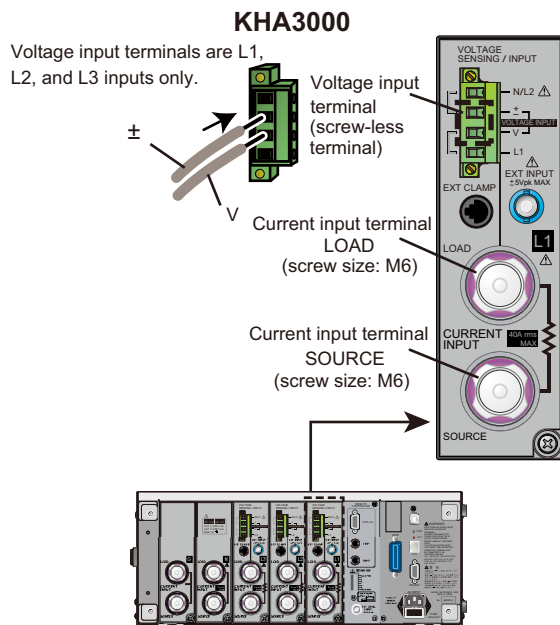
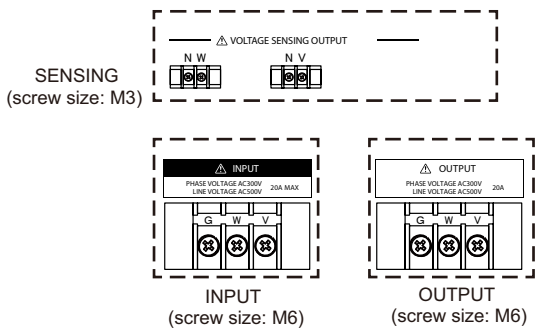

## LIN1020JF + OP01 + one PCR-LE2: single-phase and three-phase

1P2W

1P3W

3P3W

3P4W

Nominal cross-sectional area of wires  
 — 22 mm<sup>2</sup>  
 — 0.75 mm<sup>2</sup>

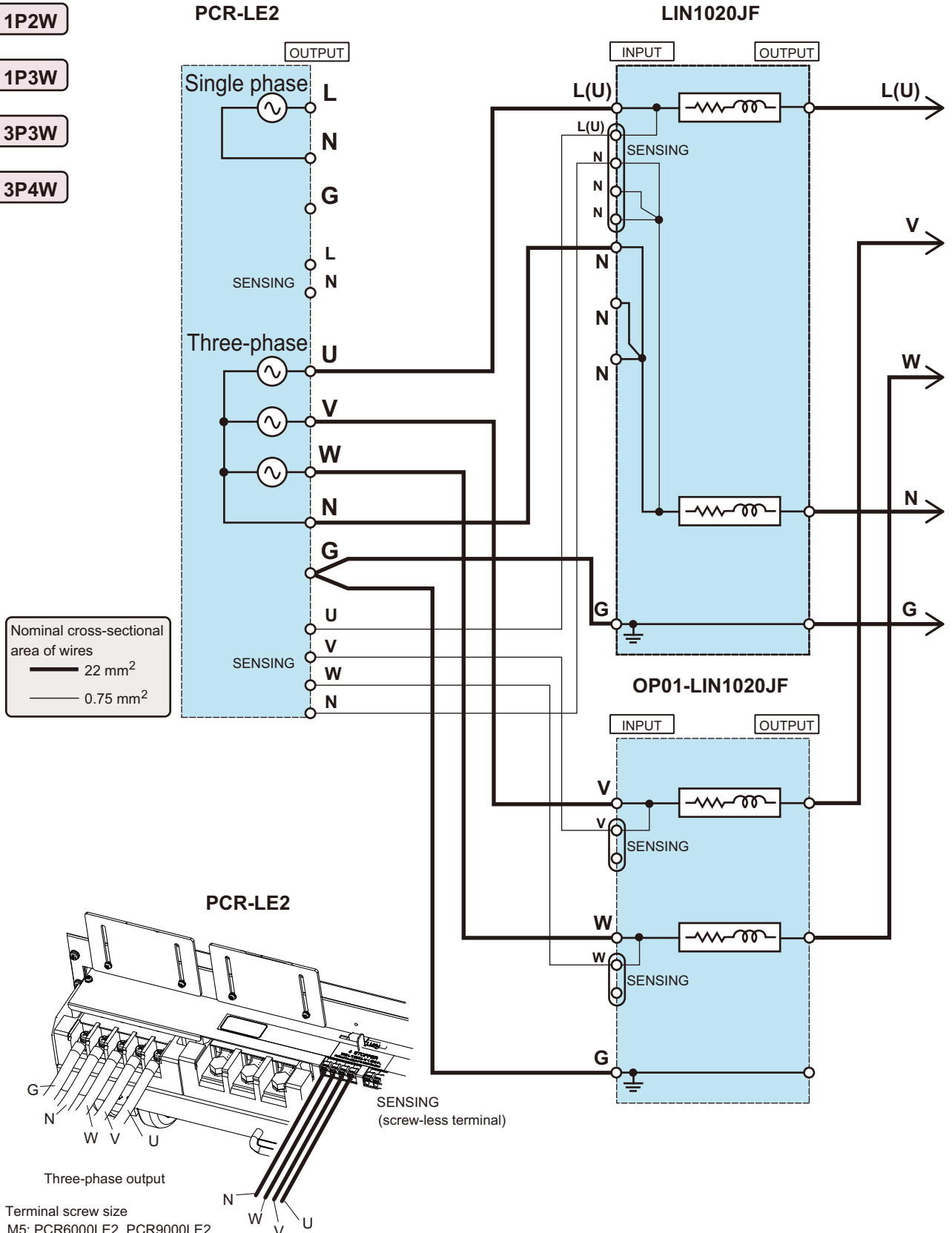

Terminal screw size  
 M5: PCR6000LE2, PCR9000LE2  
 M8: PCR27000LE2

The output terminal shape on the PCR27000LE2 is different from what is shown above. For details see the PCR-LE2 setup guide or user's manual.

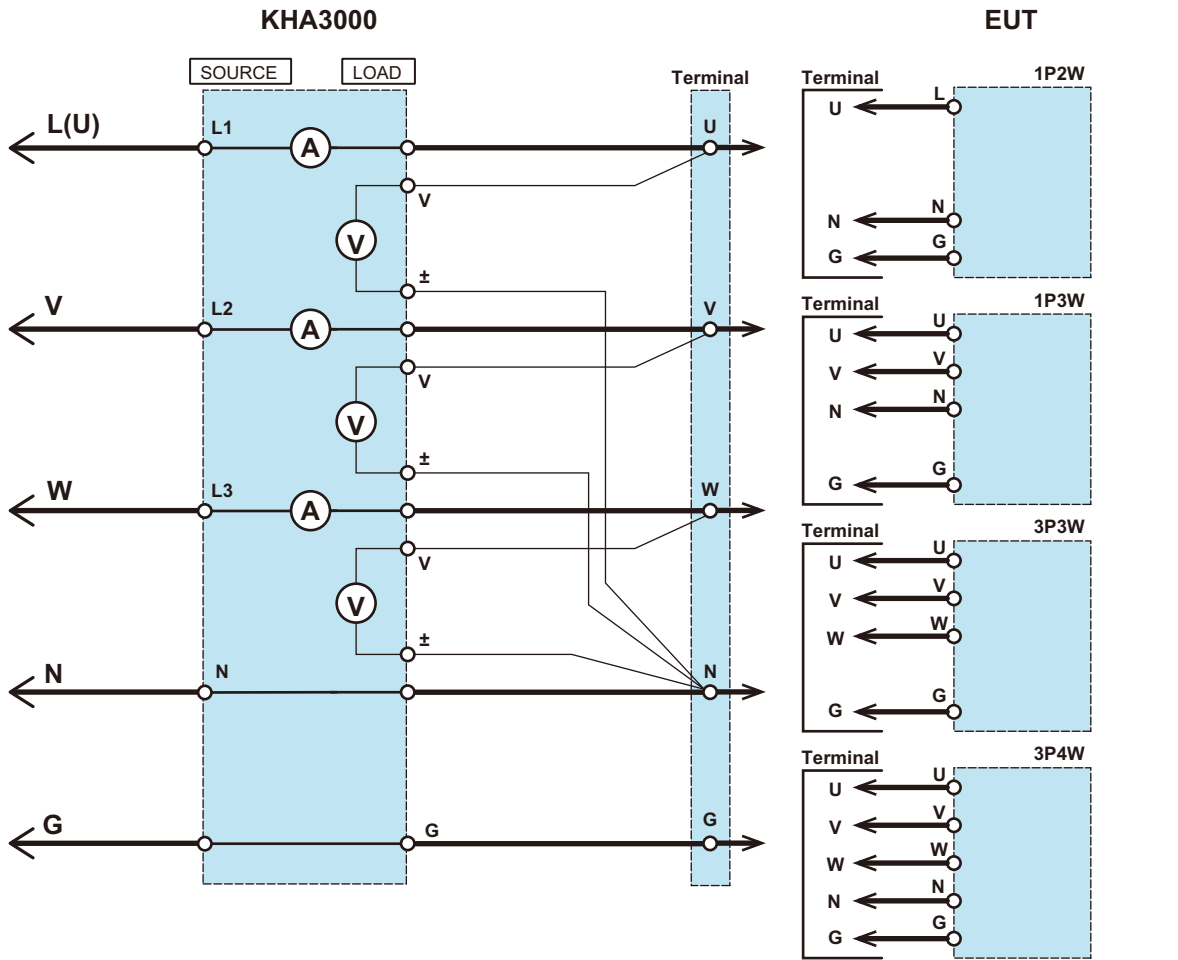

In this wiring diagram, the 1P2W power is one-third of the three-wire power. Likewise, the 1P3W power will be two-thirds.

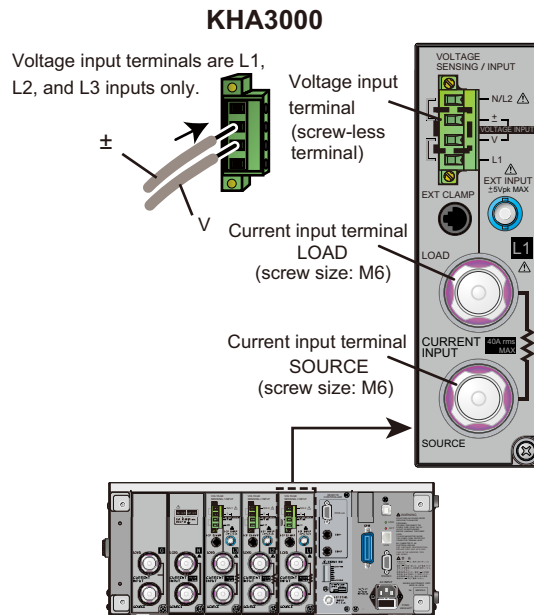
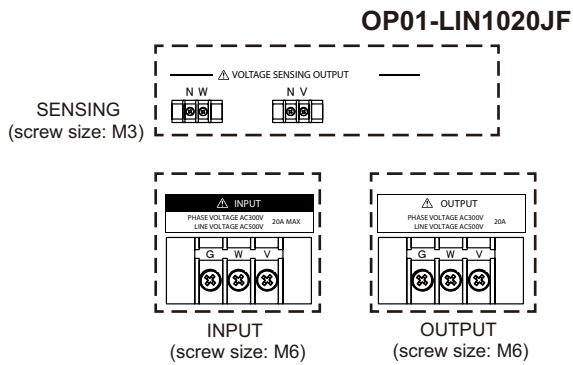
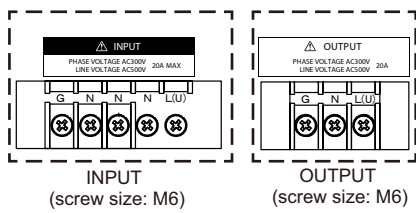
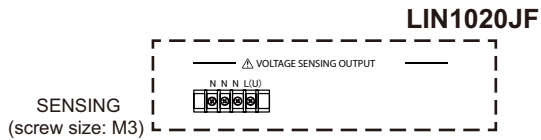

This page has been intentionally left blank.



# 5 Wiring the LIN3020JF

See p.21

This chapter provides wiring diagrams of test circuits that use the LIN3020JF.

For general information related to the wiring of test circuits, see chapter 3, "Wiring the Test Circuit".

The wiring diagrams of test circuits provided in the following pages contains the following types. Select the test circuit appropriate for your EUT.

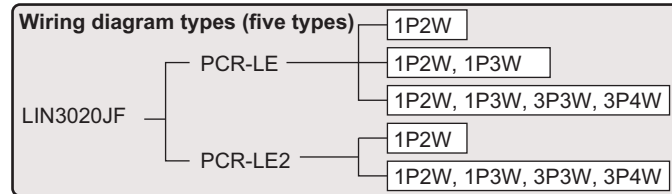

**WARNING**

**Risk of electric shock.**

- **Never connect the terminals on the INPUT or OUTPUT terminal blocks of the LIN-JF to the AC line. The internal circuit of the LIN-JF is not designed to be connected to the AC line.**

# LIN3020JF + one PCR-LE: single-phase

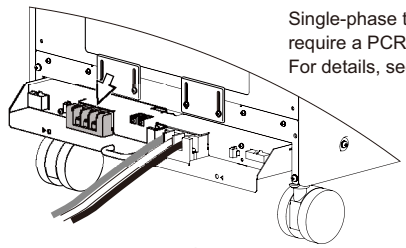
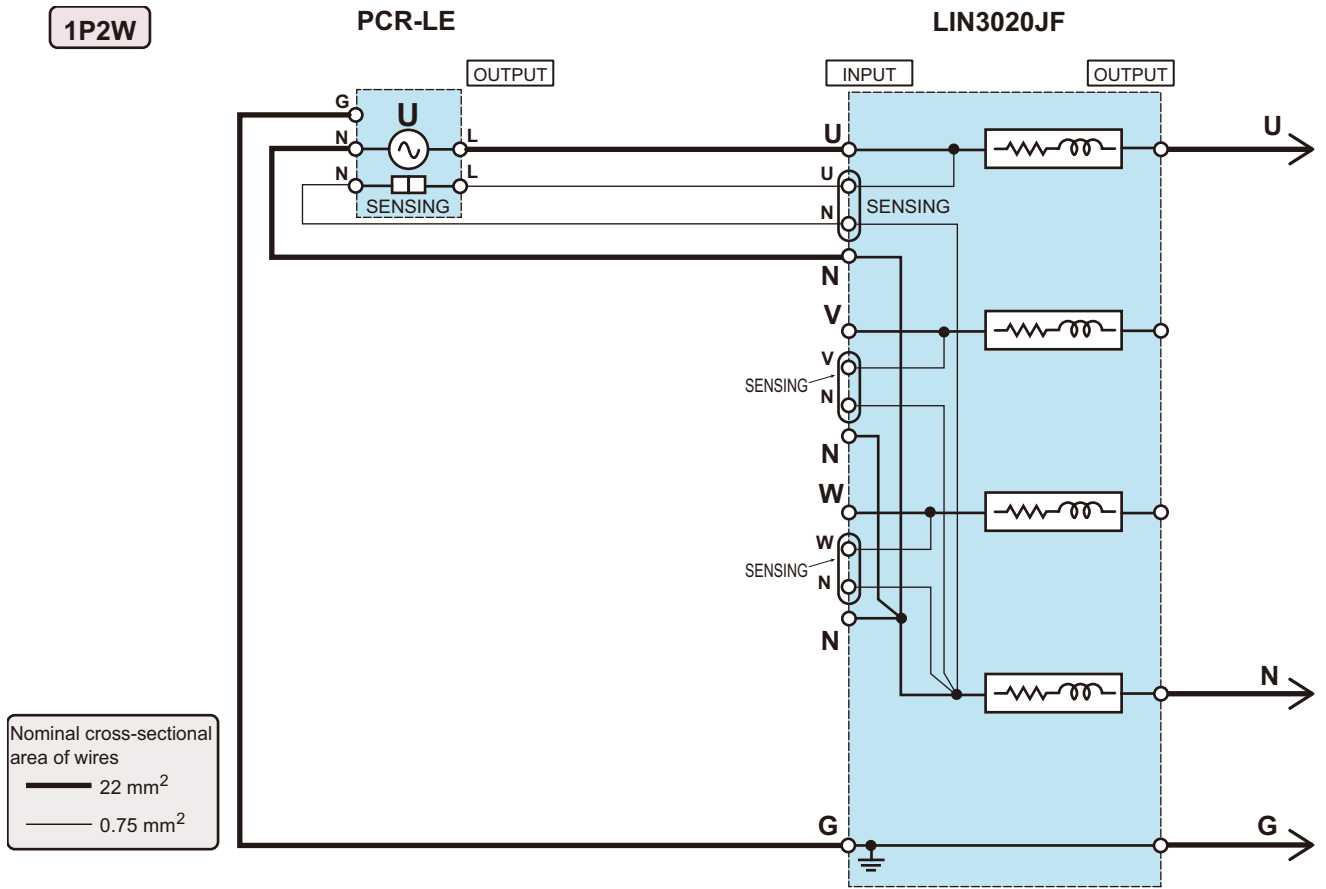

### PCR-LE

Single-phase three-wire and three-phase operations require a PCR-LE option. For details, see the PCR-LE manual.

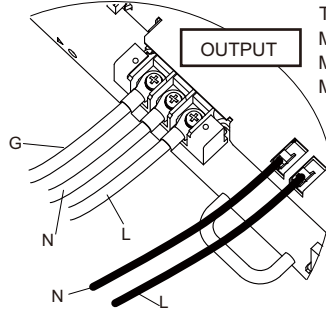

Terminal screw size  
 M4: PCR1000LE, PCR2000LE  
 M5: PCR3000LE, PCR4000LE  
 M6: PCR6000LE, PCR9000LE

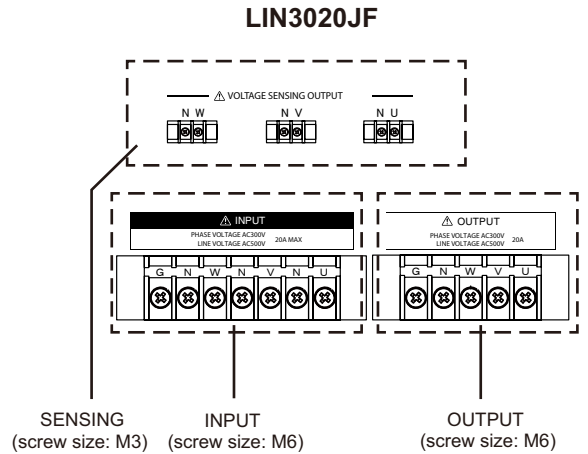

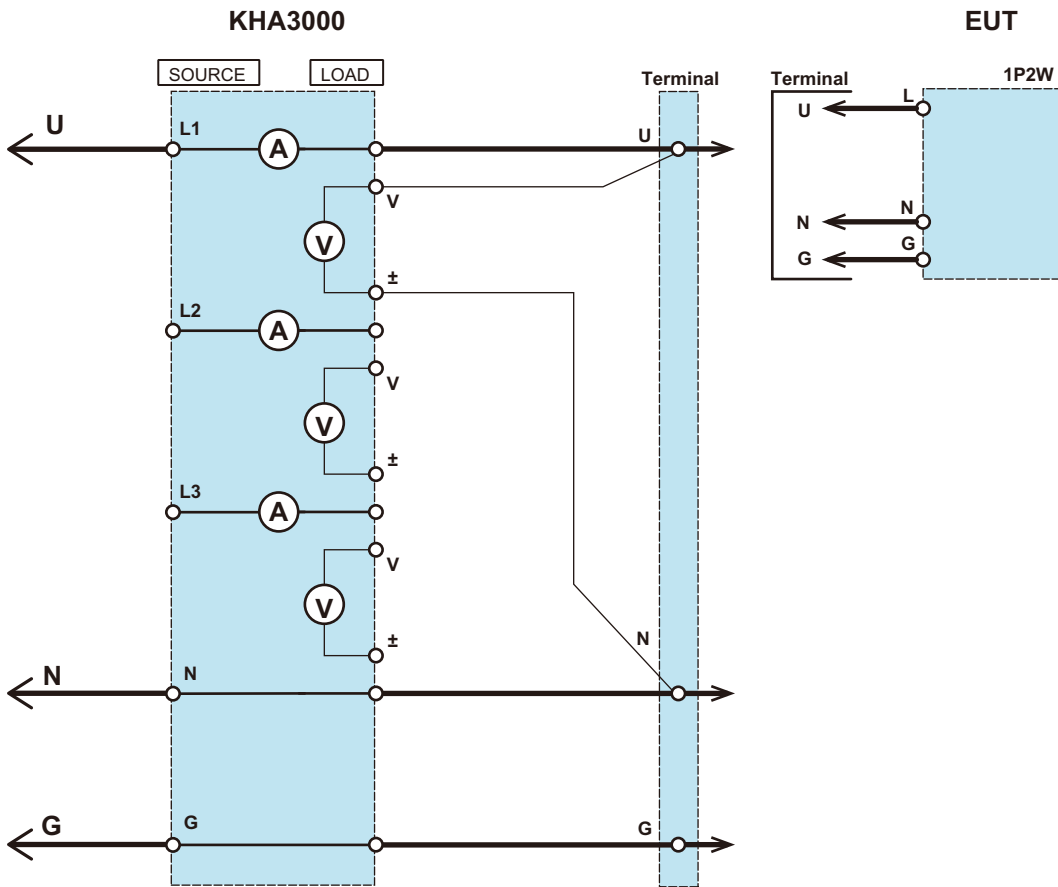

**KHA3000**

Voltage input terminals are L1, L2, and L3 inputs only.

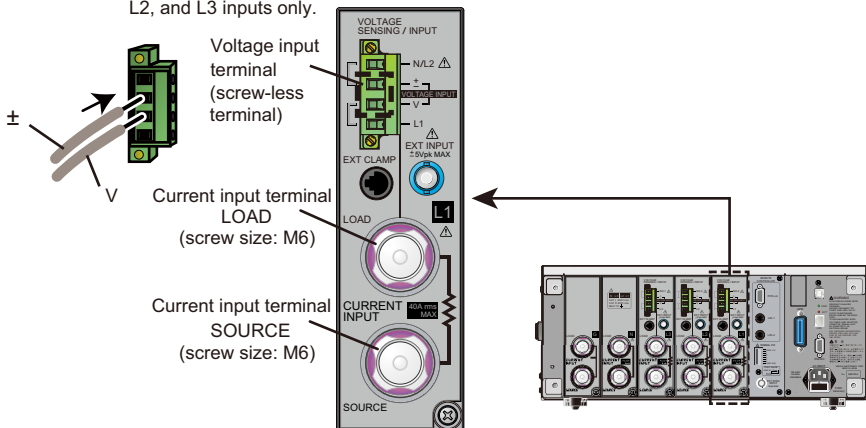

# LIN3020JF + two PCR-LE: single-phase and single-phase three-wire

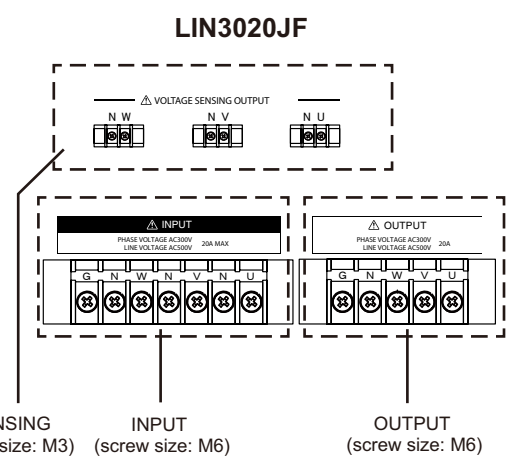
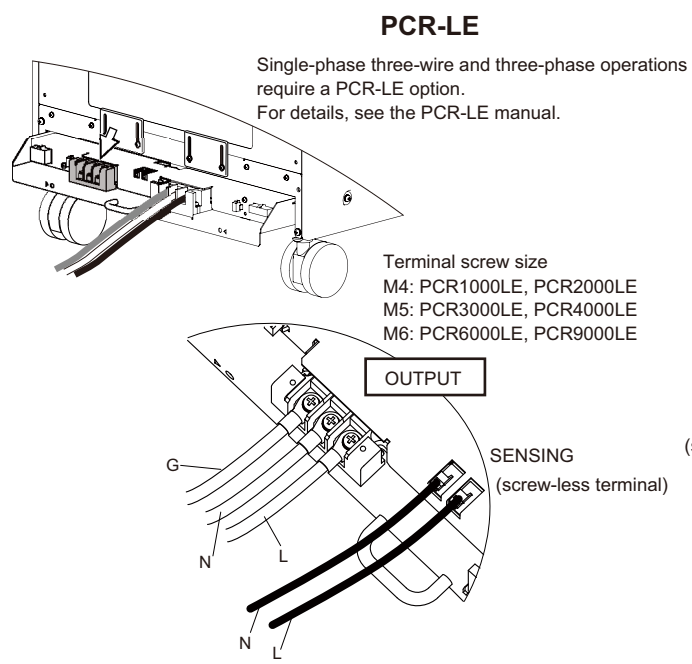
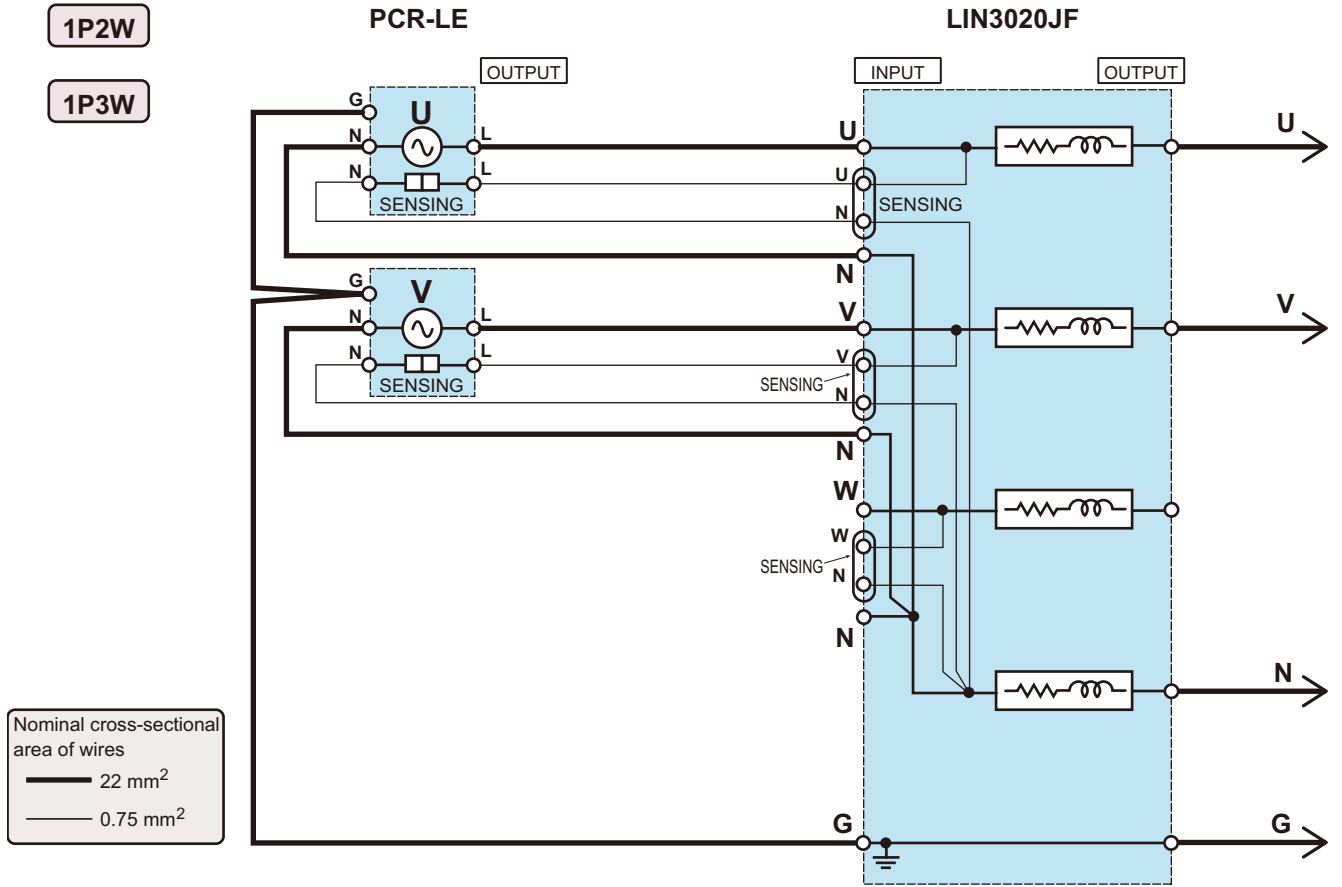



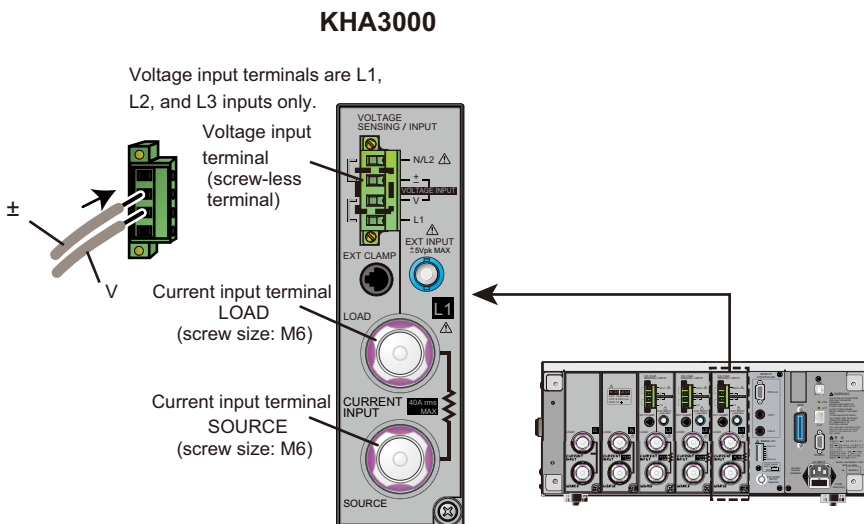
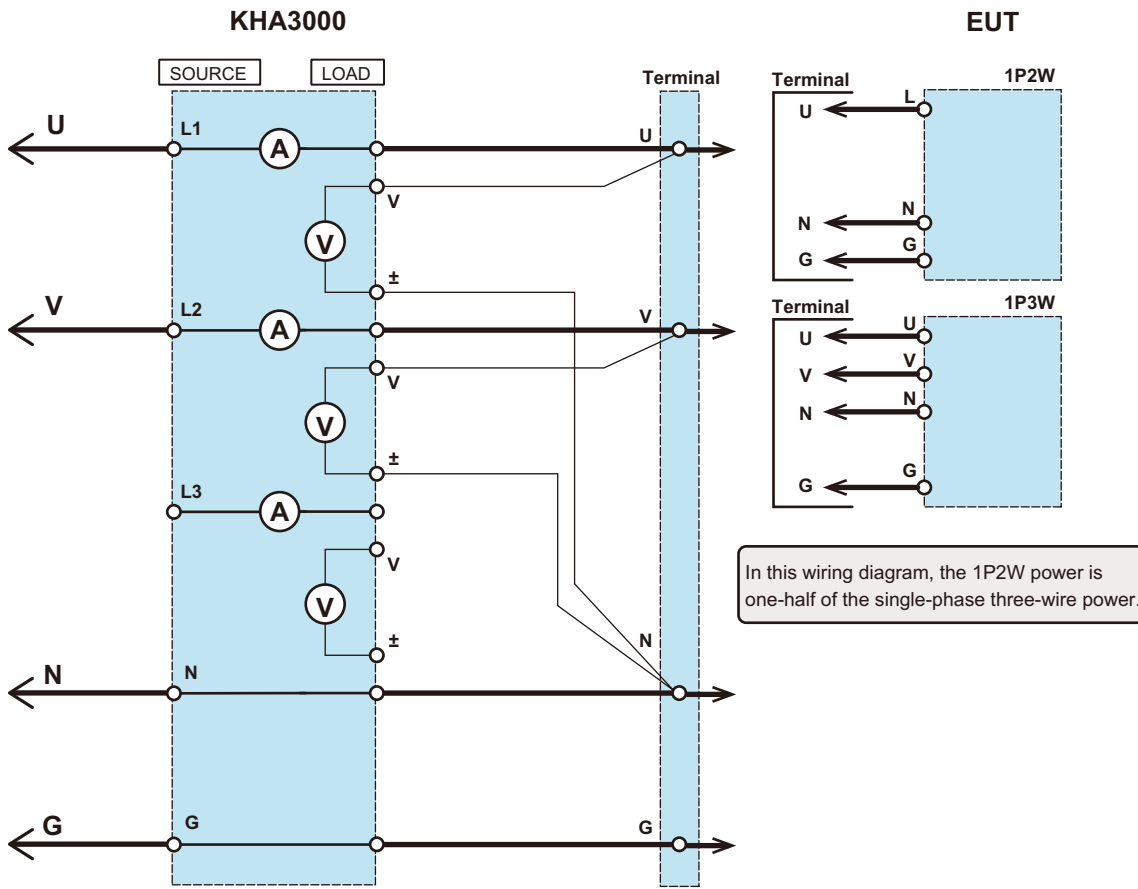

# LIN3020JF + three PCR-LEs: single-phase and three-phase

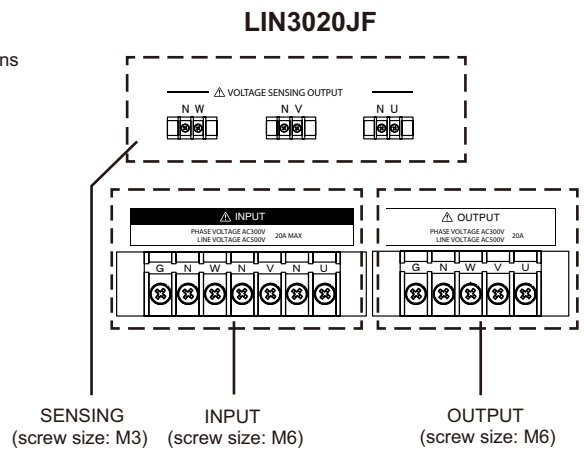
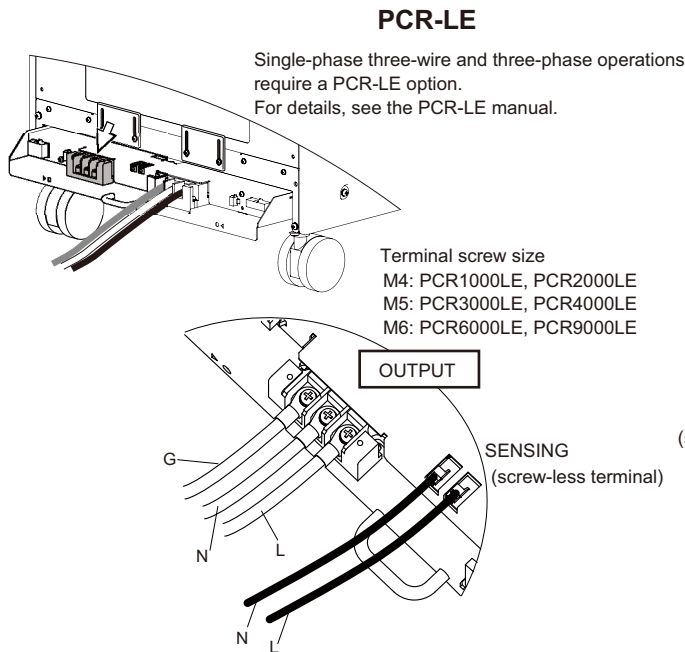
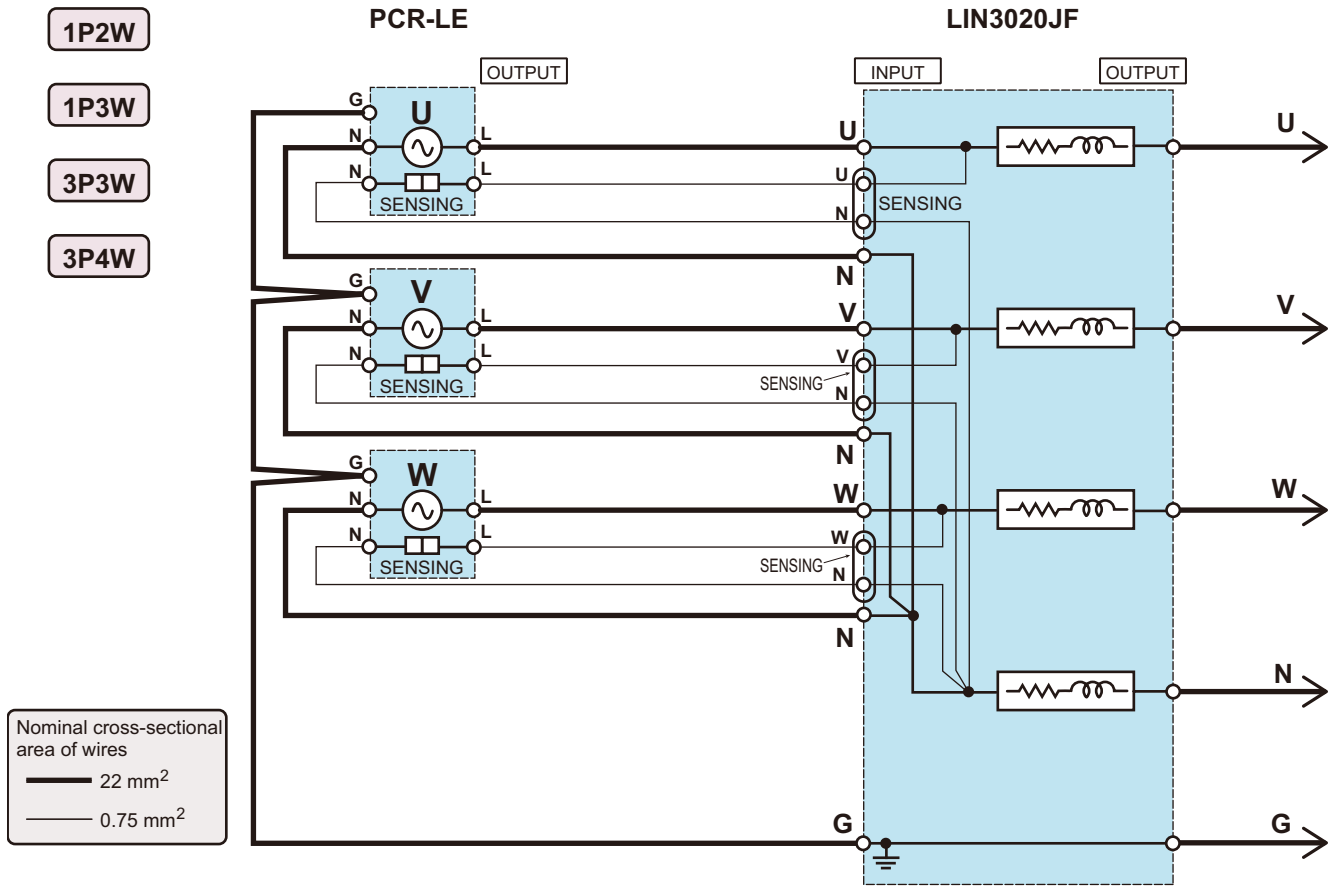

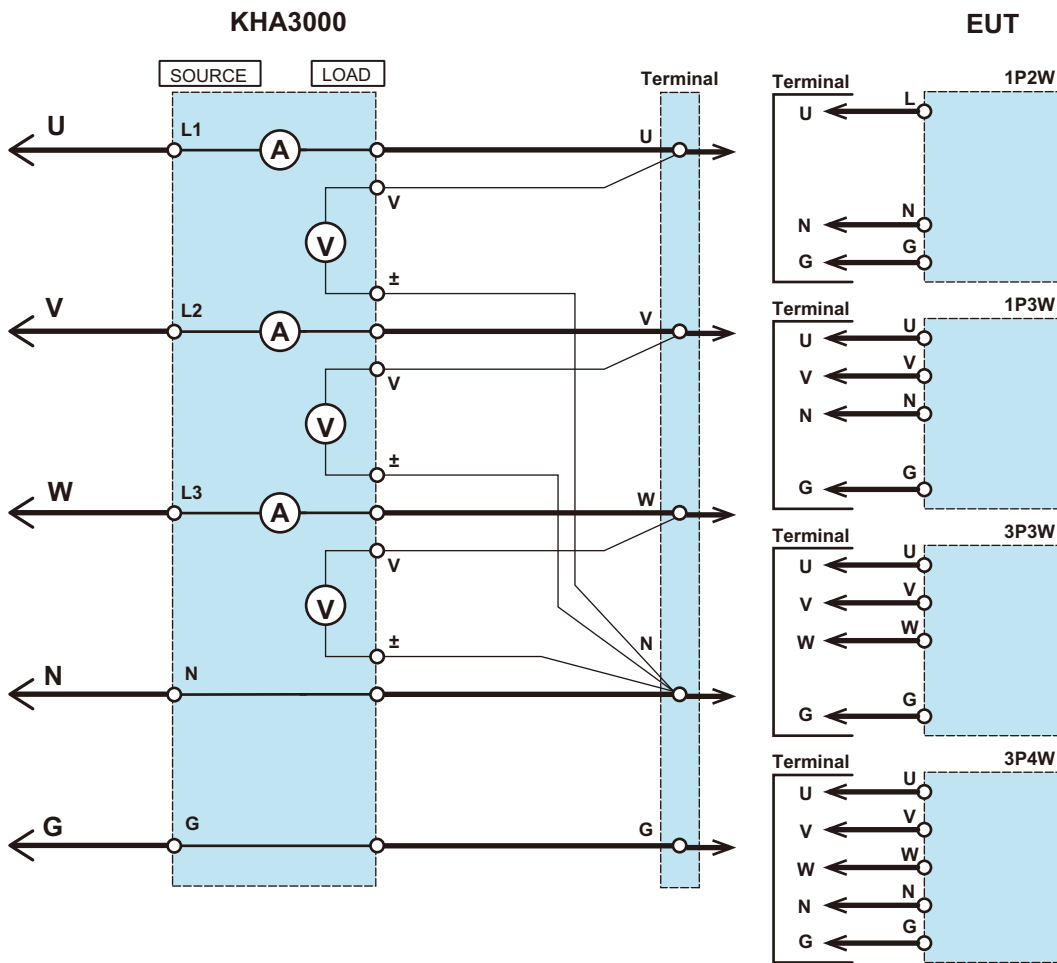

**KHA3000**

Voltage input terminals are L1, L2, and L3 inputs only.

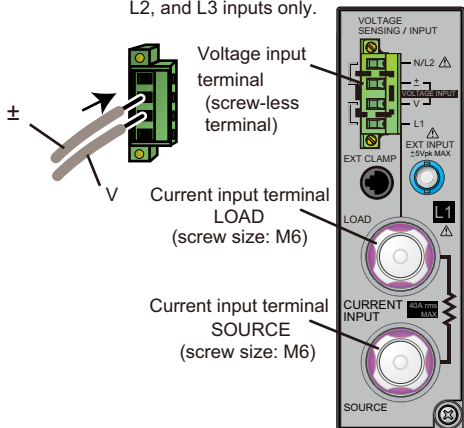

In this wiring diagram, the 1P2W power is one-third of the three-wire power. Likewise, the 1P3W power will be two-thirds.



# LIN3020JF + one PCR-LE2: single-phase

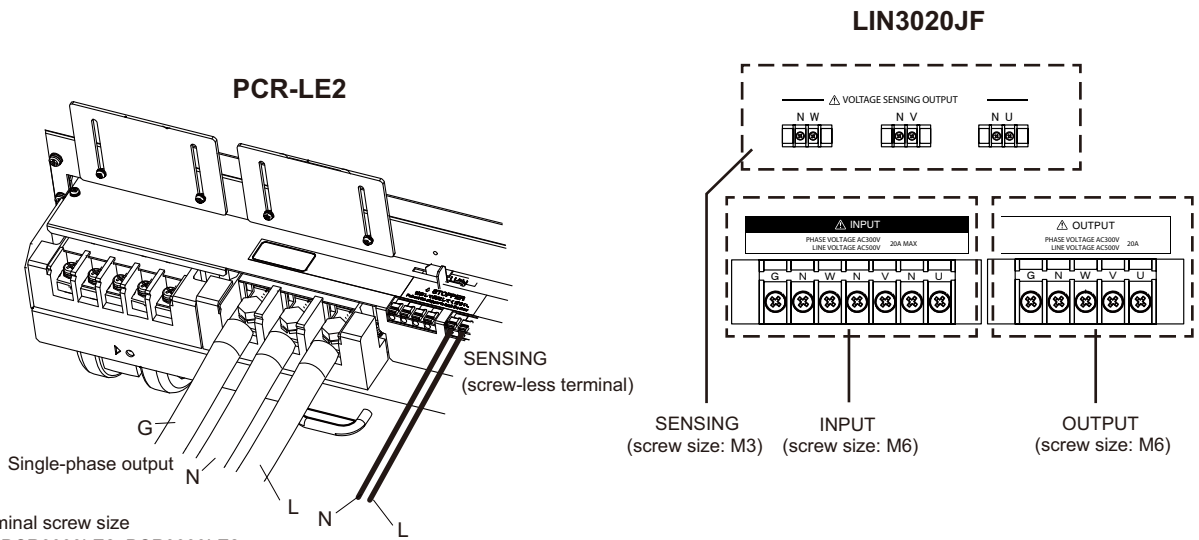
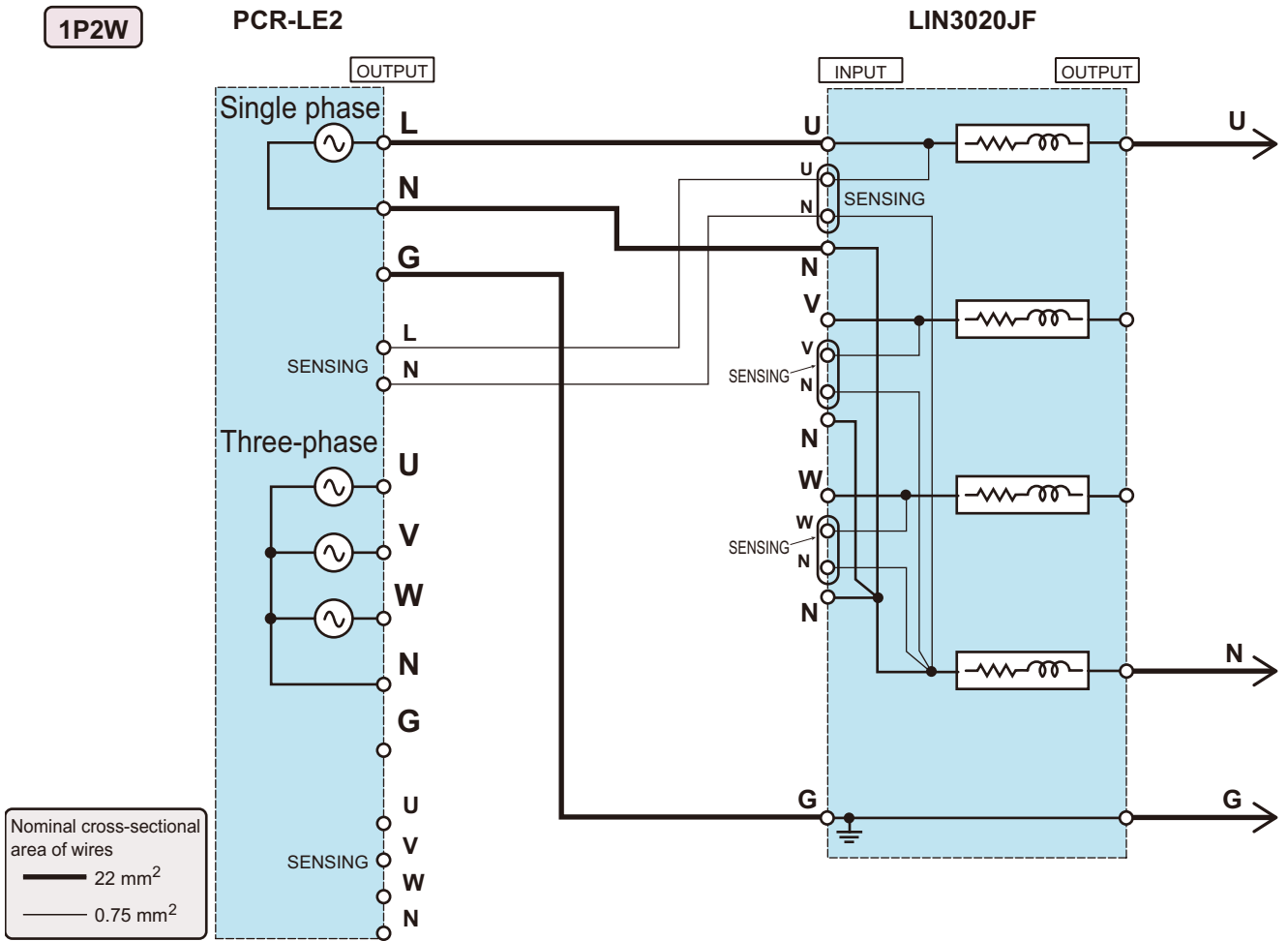

Terminal screw size  
 M8: PCR6000LE2, PCR9000LE2  
 M8: PCR27000LE2

The output terminal shape on the PCR27000LE2 is different from what is shown above. For details see the PCR-LE2 setup guide or user's manual.

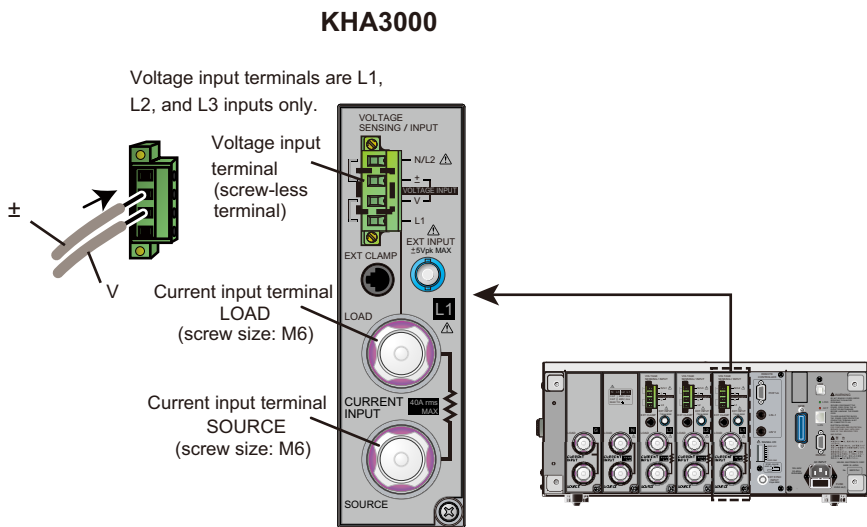
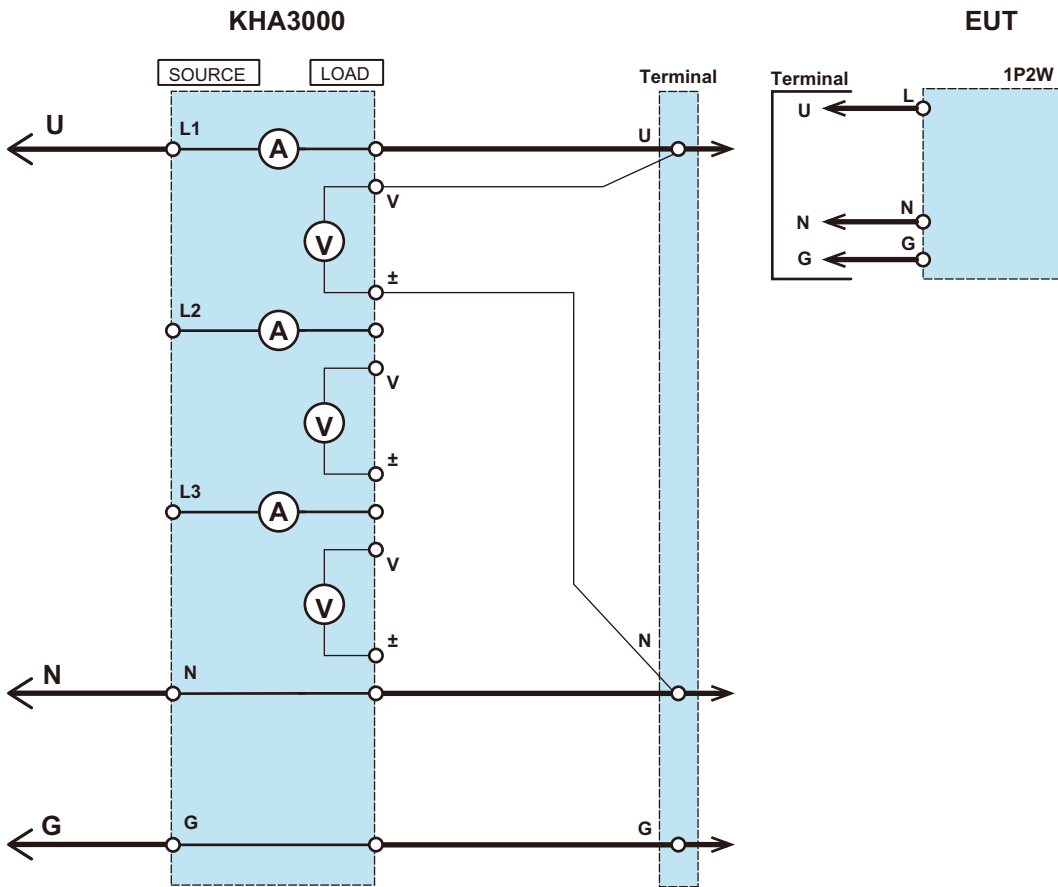

# LIN3020JF + one PCR-LE2: single-phase and three-phase

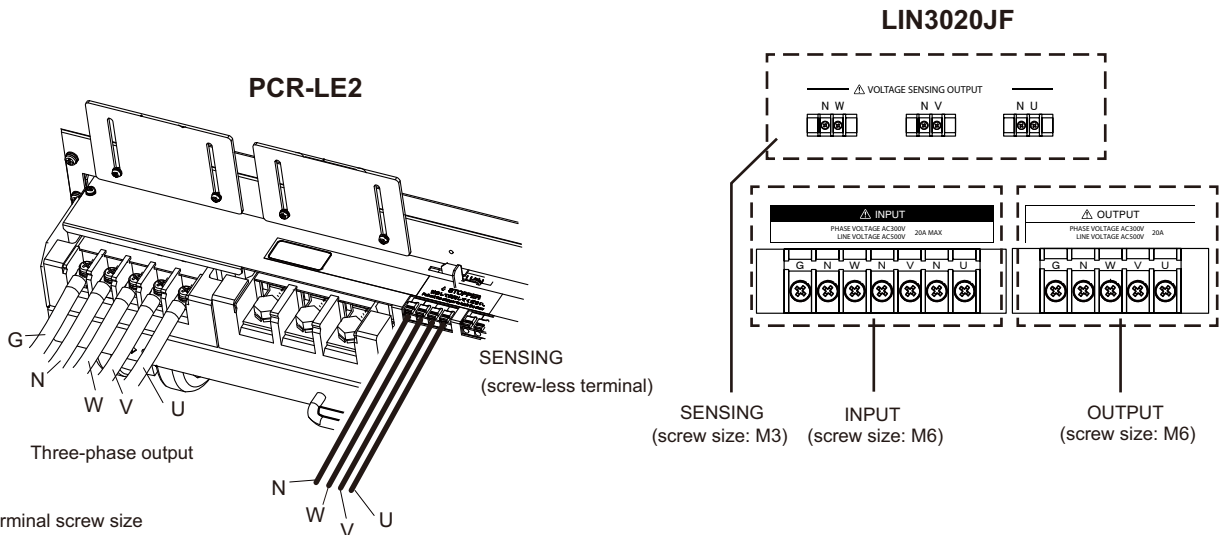
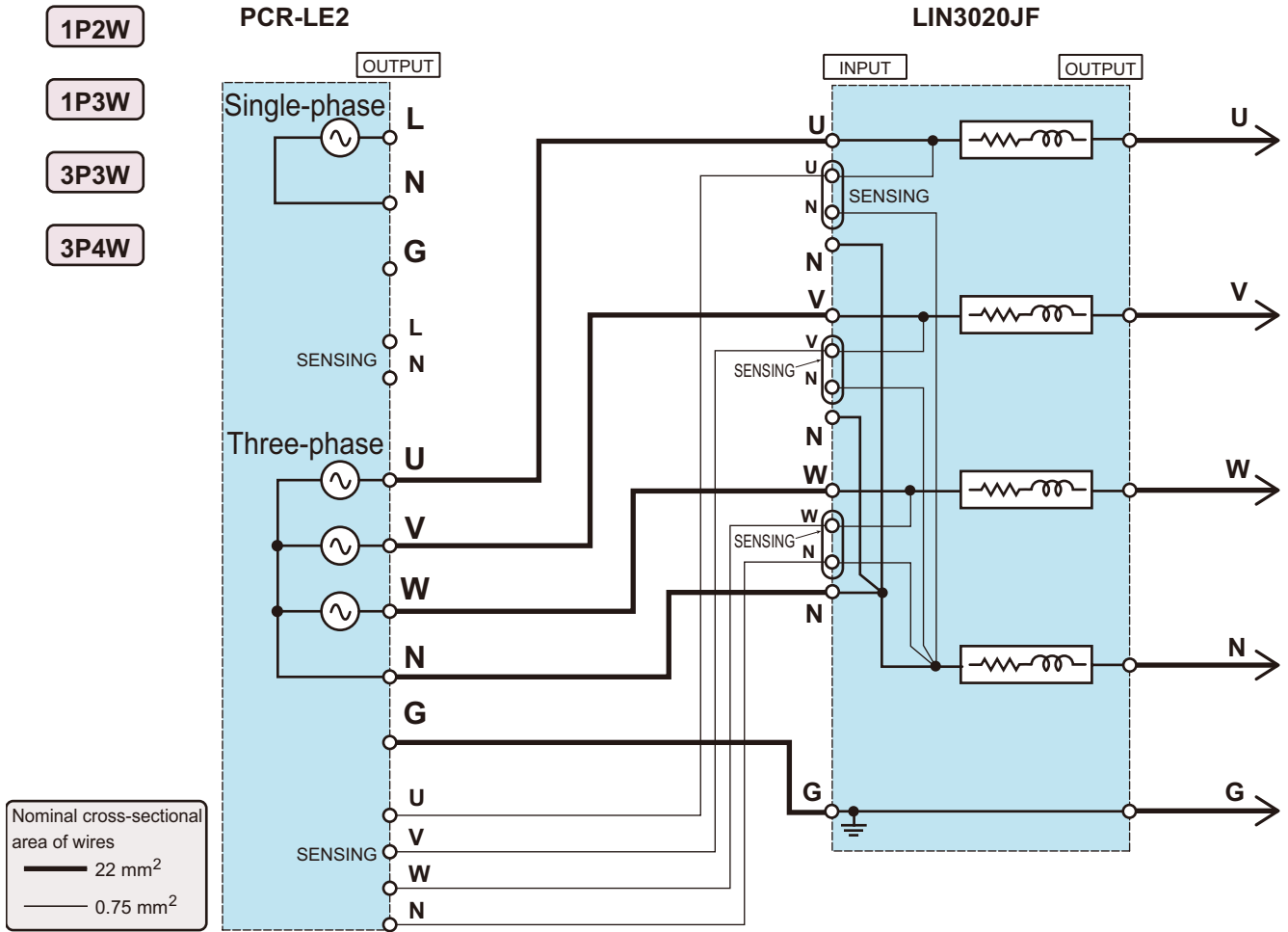

Terminal screw size  
 M5: PCR6000LE2, PCR9000LE2  
 M8: PCR27000LE2

The output terminal shape on the PCR27000LE2 is different from what is shown above.  
 For details see the PCR-LE2 setup guide or user's manual.

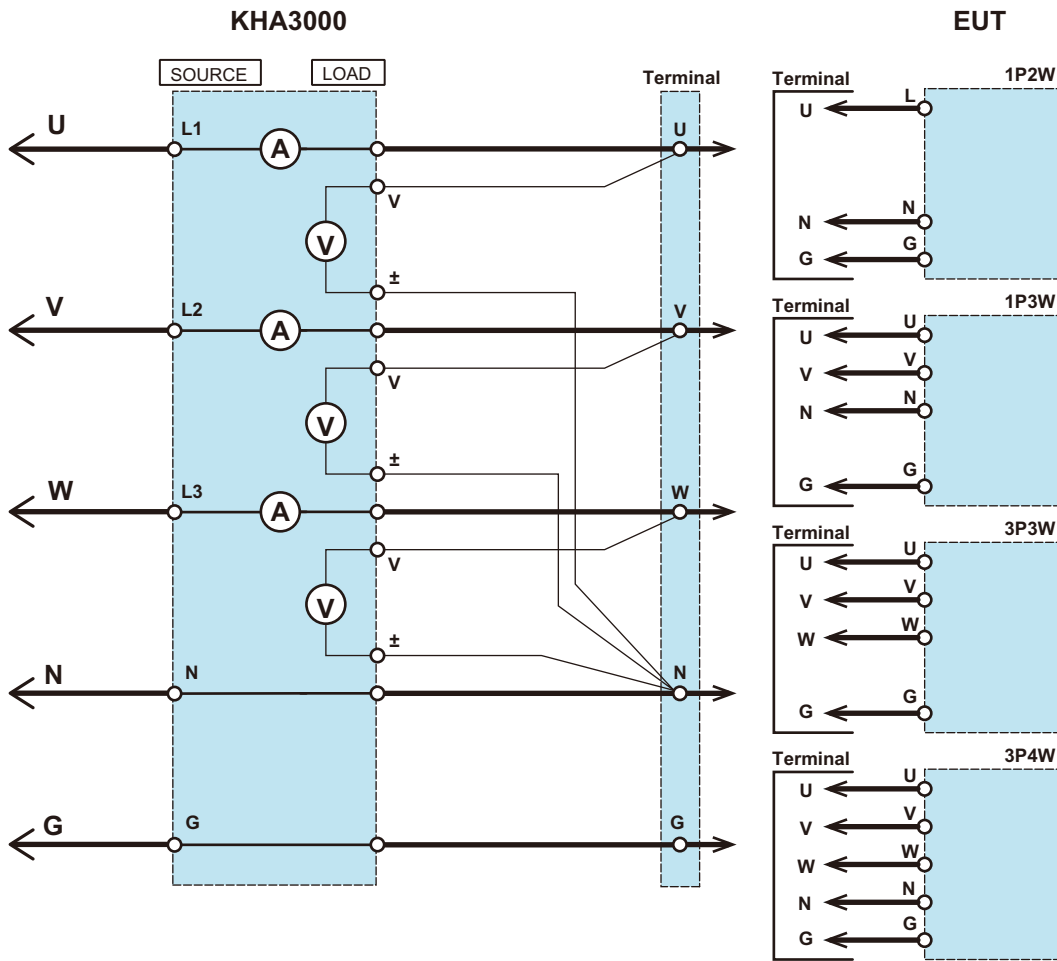

**KHA3000**

Voltage input terminals are L1, L2, and L3 inputs only.

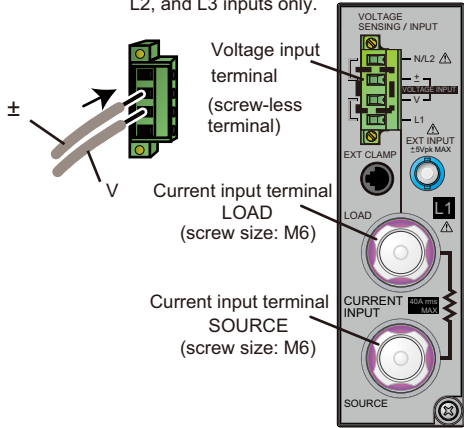

In this wiring diagram, the 1P2W power is one-third of the three-wire power. Likewise, the 1P3W power will be two-thirds.

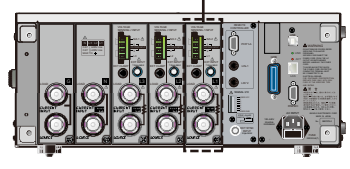

# 6 Operation

This chapter describes how to turn on the product, how to select the impedance, and how to handle alarms.

## Powering On

### Turning on the POWER switch

- 1 Turn on the POWER switch of this product.**  
The power indicator turns on, and the cooling fan starts running.

## Panel Operation

LIN1020JF

LIN3020JF

The panel control described below is for the LIN1020JF and LIN3020JF. The OP01-LIN1020JF is used in combination with the LIN1020JF and is controlled from the LIN1020JF panel. The OP01-LIN1020JF panel is for display only. It shows information according to the operations performed on the LIN1020JF panel.

### Selecting the impedance

There are impedance (IMPEDANCE SELECT) switches for Z1, Z2, Z3, and BYPASS. Each switch is an independent bi-stable push switch. The switch is on when the button is pressed in (illumination area is turned on) and off when the button is not (illumination area is turned off). The button toggles between on and off each time you press it.

The switches are not interlocked. As such, if multiple switches are on at the same time, all the selected circuits will be connected in parallel.

If all switches are off, no impedance is selected, and the N-phase circuit is open.

- 1 Turn off the AC power supply output.**
- 2 Turn off the REMOTE switch on the front panel.**  
Set the switch so that the button is not pressed in. The illumination area of the REMOTE switch will turn off, and panel control will be enabled.
- 3 Turn off all impedance (IMPEDANCE SELECT) switches on the front panel.**  
Press one of the Z1, Z2, Z3, and BYPASS switches.  
The illumination area of the selected switch will turn on.
- 4 To select another impedance, press the impedance switch that you want to turn on and then the switch you want to turn off.**



### ■ Operation example

The following procedure is for switching from Z1 to Z2.

- 1 Press Z2.**  
The Z1 and Z2 illumination areas turn on. Both impedance switches are on in this condition.
- 2 Press Z1.**  
The Z1 illumination area turns off, leaving only Z2 selected.

## Configuring the AC Power Supplies

The configuration of the AC power supplies provided below is necessary when using this product. For details, see the manual for the PCR-LE or PCR-LE2 series.

### Setting hardware sensing

To cancel out the effects of wiring impedance (between the AC power supply output and LIN-JF), be sure to enable hardware sensing (SENS-H). Otherwise, there will be errors in the impedance value and will prohibit accurate measurements.

### Setting the response

To perform harmonic or flicker evaluation of an EUT with a large capacitor in its input power supply circuit, set the AC power supply response to SLOW (highly stable). When this product's impedance is set to BYPASS for such an EUT, if the AC power supply response is set to MEDIUM (normal speed), the AC power supply response may become unstable (may oscillate).

## Output current limit of the AC power supplies

---

The maximum rated current of this product is 20 Arms (continuous).



- To ensure safety of this product and EUT, set the output current of the AC power supplies to 20 A or less. Set a current limit on the AC power supply output to prohibit the output from exceeding 20 A.

We recommend that you use the current limit feature on the AC power supplies to prevent the test circuit from overheating due to overcurrent and to protect the EUT. The overheat protection of this product shuts off the current if the internal resistive element heats up due to overcurrent.

## Power level supplied from the test circuit to the EUT

---

With the test circuit common to single-phase and three-phase, the 1P2W power will be one-third that of three-phase power. Likewise, the 1P3W power will be two-thirds.

Example: If the three-phase power is 6000 W, the 1P2W power will be 2000 W, and the 1P3W power will be 4000 W.

# Configuring the KHA3000

---

### For three-phase three-wire circuits

 p.70

When used in a three-phase test circuit, the KHA3000 voltmeter is designed to be used in a three-phase four-wire system. To use it in a three-phase three-wire circuit, you can use the delta transformation feature of the KHA3000, rather than changing the actual wiring. The delta transformation feature is used to convert phase voltage measurements to line voltages. For the setup procedure, see “Delta transformation (star-delta transformation)” in the appendix.

# Handling Overheat Alarms

When the overheat protection function of this product is activated, the internal phase circuits are opened, shutting off the current. If the PCR CONTROL terminal function is used, the AC power supply output can also be turned off when the overheat protection function is activated. The detailed operation is described below.

## Overcurrent (when the PCR CONTROL terminal function can be used)

The overheat protection function is activated, and the AC power supply output is turned off. The LIN OVERHEAT status signal is transmitted from the STATUS OUTPUT terminal.

Step	Handling
1	Leave the product's POWER switch turned on. This will keep the fan running for cooling.
2	After cooling the product adequately, turn on the POWER switch, and investigate the cause of the overcurrent.

## Overcurrent (when the PCR CONTROL terminal function cannot be used)

 p.22

- When the PCR CONTROL terminal is not connected to the AC power supplies or the connection is incomplete

In this situation, the AC power supply output will not be turned off even when the product's overheat protection is activated. However, the LIN OVERHEAT status signal will be transmitted from the STATUS OUTPUT terminal.

Step	Handling
1	To secure safety, when the ALARM indicator on the front panel turns on, turn off the AC power supply output.
2	Leave the product's POWER switch turned on. This will keep the fan running for cooling.
3	After cooling the product adequately, turn on the POWER switch, and investigate the cause of the overcurrent.

# 7 Remote Control

This chapter describes how to use remote control through the CONTROL INPUT terminal or USB. In this manual, *contact signal control* refers to the notion of remote control using the CONTROL INPUT terminal.

## Switching to Remote Control Mode

### Switching between panel control and remote control

You can select the impedance from the front panel or through remote control.

**NOTE**

- To switch between panel control and remote control, use the REMOTE switch on the front panel. You cannot set this from a PC.

#### ■ Switching to remote control mode

- 1 Press REMOTE on the front panel to turn it on.**  
The switch is on when the button is pressed in. Remote control is enabled in this state.
- 2 Apply a remote signal to the CONTROL INPUT terminal on the rear panel.**  
When the REMOTE switch is on and the remote signal is being received, the product switches to remote control mode, and the illumination area of the REMOTE switch turns on.

#### ■ Switching to panel control mode

- 3 Press REMOTE on the front panel to turn it off.**  
The switch is off when the button is released (illumination area is turned off). The product switches to panel control mode, regardless of whether a remote signal is being received.

# Controlling the Product Using Contact Signals

You can use an external sequencer contact signal output or a digital I/O controller through the CONTROL INPUT terminal to select the product's impedance. You can use the STATUS OUTPUT terminal to check the product status.

## CONTROL INPUT terminal LIN1020JF LIN3020JF

No.	Signal name	Relay operation current	Function
1	24 Vdc	—	Internal power supply output (with a 470 $\Omega$ protective resistor)
2	Z1	100 mA or less	Selects impedance Z1
3	Z2		Selects impedance Z2
4	Z3		Selects impedance Z3
5	NC	—	—
6	NC	—	—
7	NC	—	—
8	REMOTE	100 mA or less	Enables remote control
9	BYPASS		Bypasses the impedance
10	Circuit common	—	—

The current absorption by an external circuit activates the internal relay. Of Z1, Z2, Z3, and BYPASS, only one can be selected at any given time. If all switches are off, no impedance is selected, and the N-phase circuit is open. The internal relay operation current is approximately 100 mA<sub>dc</sub> (24 V<sub>dc</sub> open voltage or less).

Example: Selecting impedance Z1

Set the REMOTE terminal to low level (connect to the circuit common). Next, set the Z1 terminal to low level (connect to the circuit common). This will select impedance Z1.

## STATUS OUTPUT terminal LIN1020JF LIN3020JF

No.	Signal name	Contact rating	Function
1	24 Vdc	—	Internal power supply output (with a 470 $\Omega$ protective resistor)
2	RESERVE	5 A <sub>dc</sub> , 35 V <sub>dc</sub>	Reserved bit: Fixed to low (short circuit)
3	RESERVE		Reserved bit: Fixed to open
4	LIN OVERHEAT	—	Overheat alarm
5	REMOTE/LOCAL	—	Remote mode
6	NC	—	—
7	NC	—	—
8	RESERVE	5 A <sub>dc</sub> , 35 V <sub>dc</sub>	Reserved bit: Fixed to low (short circuit)
9	RESERVE		Reserved bit: Fixed to low (short circuit)
10	Circuit common	—	—

Contact output. The contact is active when it is shorted. When shorted, the contact is connected to the internal circuit common (contact rating of 5 A<sub>dc</sub>, 35 V<sub>dc</sub>). When the contact is opened, the terminal potential is also opened.

- **LIN OVERHEAT (overheat alarm)**

This status signal is transmitted when the product's internal overheat protection function is activated. It is used to control external devices.

- **REMOTE/LOCAL:** This status signal indicates that the product is operating in remote mode.

**NOTE**

- If the PCR CONTROL terminal is connected properly to the AC power supplies, the AC power supply output will be turned off when the overheat protection of this product is activated.

**Example of contact signal control**

The figure below shows a connection example for contact signal control. Isolate the contact signal control circuit from the internal circuit of this product with a photocoupler. The coil current of this product's impedance selection relay is 100 mA or less.

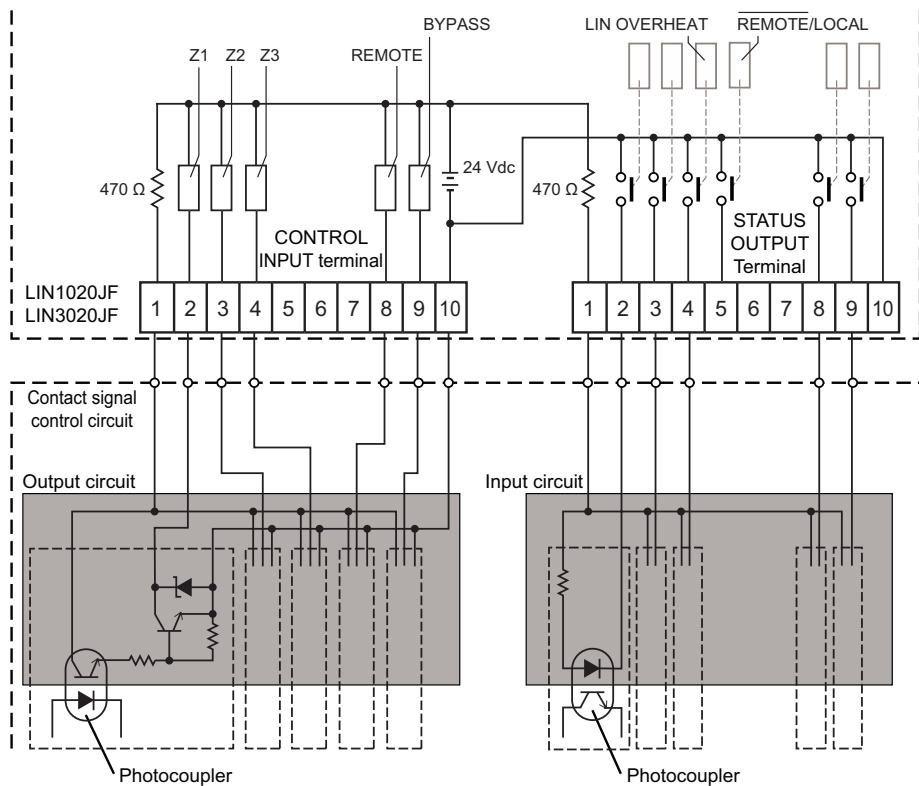

**Example of a contact signal control device (reference)**

To perform contact signal control, we recommend that you use the DIO-0808LY-USB Isolated Digital I/O Terminal for USB2.0 (hereafter abbreviated as DIO) made by CONTEC. The DIO connectors CN1 and CN2 are used for this purpose.

Connect the product's CONTROL INPUT terminal to CN1 and the STATUS OUTPUT terminal to CN2. Connect the interface connector to a PC's USB port.

For details on the DIO connectors, see the Isolated Digital I/O Terminal for USB2.0 DIO-0808LY-USB User's Guide.

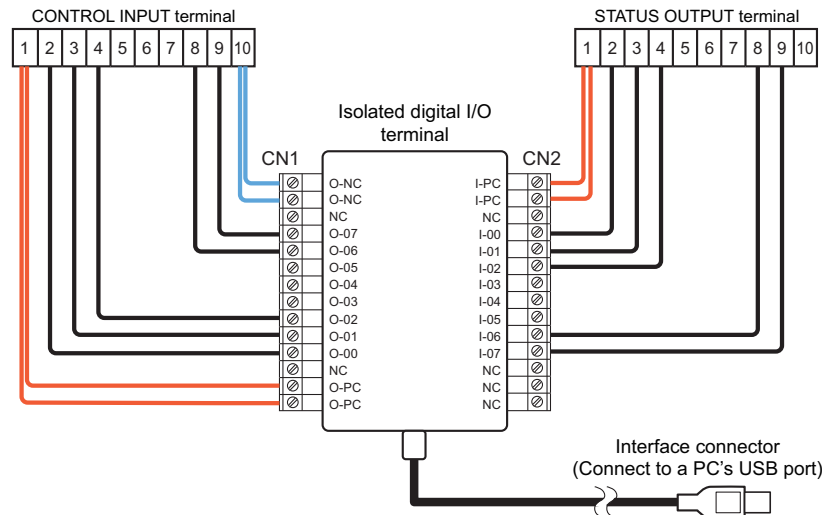

Connectors CN1 and CN2 are screw terminal blocks. The nominal cross-sectional area of wires is 0.08 mm<sup>2</sup> (AWG28) to 0.75 mm<sup>2</sup> (AWG18). The length of stripped wires is 9 mm to 10 mm.

## Controlling the Product Using USB

A DIO is built into this product. You can remotely control this product through the USB port. For details on the operation, see the CONTEC API-USBP (WDM) help file.

### USB port LIN1020JF LIN3020JF

The USB port is available on the LIN1020JF and LIN3020JF. To use remote control, connect the USB port to a USB port on your PC.

The figure below shows how the USB port is connected internally. For details how to use the DIO, see the CONTEC API-USBP (WDM) help file.

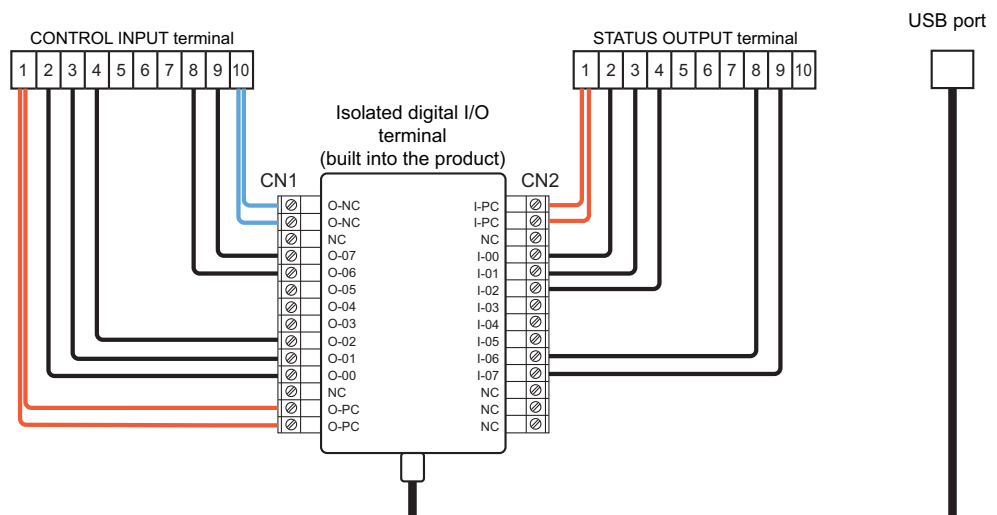

See p.54

### ■ Using the USB port and CONTROL INPUT terminal simultaneously

In remote control through the USB port, the control signal from the CN1 terminal (see the figure on the previous page) is connected to the product's CONTROL INPUT terminal. The output from the CN1 terminal is an open-collector circuit.

If you connect an open-collector circuit isolated by a photocoupler to the CONTROL INPUT terminal, you will be able to use the USB port and the CONTROL INPUT terminal simultaneously.

The coil current of this product's impedance selection relay is 100 mA or less. When the USB port and the CONTACT INPUT terminal are used simultaneously, the CONTROL INPUT terminal signal will be the logical sum of both signals. Apply a signal appropriate for the terminal signal logic.



#### CAUTION

Risk of malfunction.

- Isolate the contact signal control circuit from the internal circuit of this product with a photocoupler, and use an open-collector circuit.

## Installing the driver

- 1 Set the supplied CD-ROM (API-USBP (WDM) driver software) by CONTEC) in the PC's CD drive.**
- 2 Check that the USB cable is connected properly between the product's USB port and PC.**
- 3 Turn on the POWER switch of this product.**  
"Found new hardware wizard" starts.  
If the wizard does not start automatically, install the driver by double-clicking Setup.exe in the "X:\INF\WDM\Dio" folder (where X is the CD-ROM drive) in the CD-ROM and clicking "API-DIO (WDM) Installer."
- 4 Select "Install the software automatically," and click Next.**  
The driver installation begins.
- 5 When the installation is complete, click Finish.**

## Checking the feature

Use the CONTEC API-USBP (WDM) software supplied with the CONTEC's DIO-0808LY-USB Isolated Digital I/O Terminal for USB2.0, and check that the product can be controlled through the USB port.

For details on using the diagnosis program for checking the operation, see the Isolated Digital I/O Terminal for USB2.0 DIO-0808LY-USB User's Guide.



## Starting the diagnosis program

- 1 On your PC, choose **Computer, Properties, and then Device Manager.** “CONTEC Devices” appears in the Device Manager window.

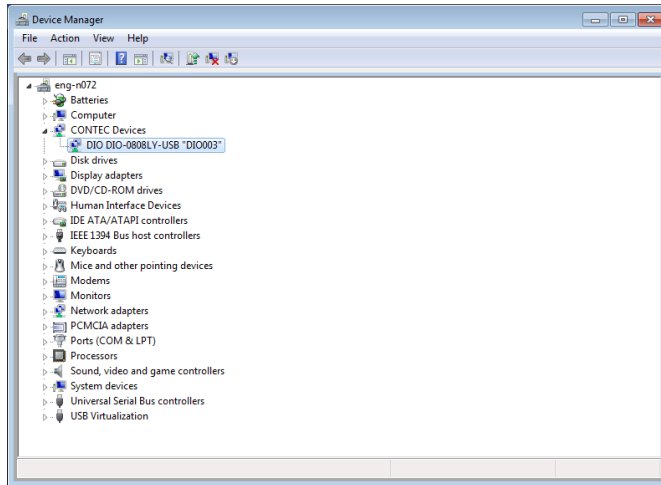

- 2 Right-click **CONTEC Devices-DIO DIO-0808LY-USB, and then click Properties.**

DIO DIO-0808LY-USB “DIO1000” Properties appear.

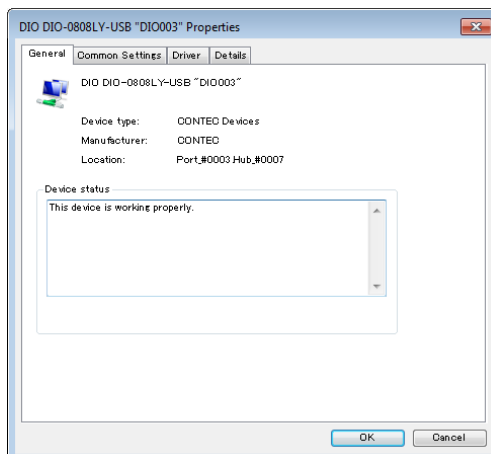

- 3 Click **Diagnosis on the Common Settings tab.**

The diagnosis program starts.

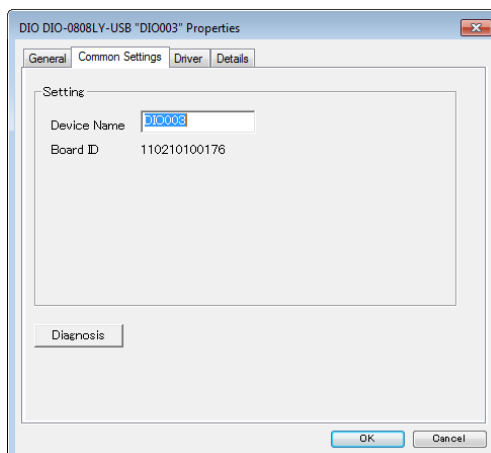

## Checking the output port operation

By controlling specific bits, you can check whether the impedance can be switched properly.

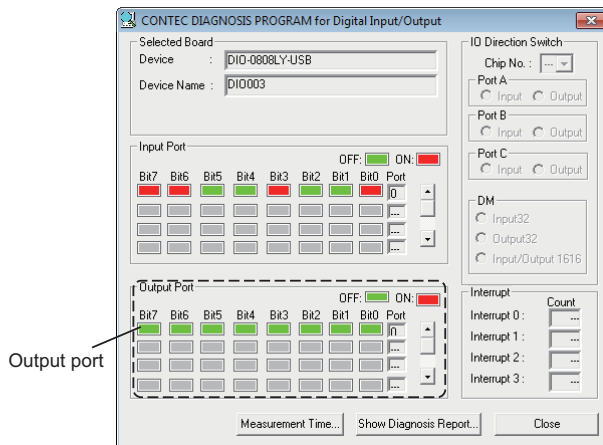

Click the bits in the output port to change the internal I/O port output. To switch the impedance, set the appropriate bits by referring to the following table.

Impedance	Bit7	Bit6	Bit5	Bit4	Bit3	Bit2	Bit1	Bit0
Z1	0	1	—	—	—	0	0	1
Z2	0	1	—	—	—	0	1	0
Z3	0	1	—	—	—	1	0	0
BYPASS	1	1	—	—	—	0	0	0

0: OFF (OPEN); displayed in green

1: ON (LOW); displayed in red

—: N/A; no effect even if set

## Checking the input port operation

You can check the product status.

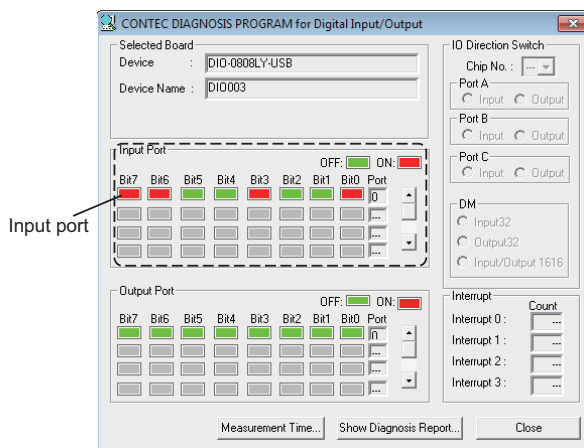

To do so, use the input port.

Status	Bit7	Bit6	Bit5	Bit4	Bit3	Bit2	Bit1	Bit0
Normal	0	1	—	—	—	0	0	1
Overheat alarm activated	0	1	—	—	—	1	0	1

0: OFF (OPEN); displayed in green

1: ON (LOW); displayed in red

—: N/A; no effect even if set

# 8 Specifications

This chapter lists the electrical and mechanical specifications of the product.

Item		LIN1020JF	LIN3020JF	OP01-LIN1020JF	
Compliant standards		JIS C61000-3-2(2011), JETGR0003-1-2.0(2011), JIS C8962(2008), IEC 61000-3-3(2008)			
Reference impedance	Supported wiring systems	Single-phase two-wire (Single-phase three-wire, three-phase three-wire, and three-phase four-wire are supported with the OP01-LIN1020JF option.)	Single-phase two-wire, single-phase three-wire, three-phase three-wire, and three-phase four-wire	Single-phase three-wire, three-phase three-wire, and three-phase four-wire (in combination with the LIN1020JF)	
	Impedance value <sup>1</sup>	U, V, and W phases	Z1, Z2: 0.19 Ω + 0.23 mH, Z3: 0.24 Ω + jn 0.15 Ω Phase impedance bypassing is possible.		
		N phase	Z1: 0.21Ω + 0.14 mH, Z2: 0.19 Ω + 0.23 mH, Z3: 0.16 Ω + jn 0.10 Ω Impedance bypassing is possible.		
	Impedance error <sup>2</sup>	Resistance	± 5 %		
		Reactance	± 5 % (50 Hz/60 Hz), ± 15 % (reference value at 1 kHz), ± 20 % (reference value at 3 kHz)		
	Residual resistance during bypass	Each phase	10 mΩ or less		
	Maximum rated voltage	Phase voltage	300 Vrms		
		Line voltage	500 Vrms		
	Maximum rated current	Each phase	20 Arms (continuous)		
	Rated frequency		50 Hz/ 60 Hz (Z1, Z2), 50 Hz (Z3)		
Input and output terminals		Terminal block, M6 screws			
Control features	Voltage sensing		Supports the hardware sensing functions of the PCR-LE and PCR-LE2 series using the internal sensing points of each phase		
		Terminal	L-N phase Terminal block, M3 screws	U-N, V-N, and W-N phases Terminal block, M3 screws	V and W phases Terminal block, M3 screws
	Contact signal control		Impedance selection using contact signals		Not available
		Operation current	Approx. 100 mA <sub>dc</sub> (24 V <sub>dc</sub> open voltage or less) per circuit; internal relay operates through current absorption by the open-collector circuit		
	Status output		Status output using contact signals		Not available
		Contact rating	5 A <sub>dc</sub> , 35 V <sub>dc</sub> Contact connected to the internal circuit common when shorted		
	USB remote control		Impedance selection and status querying using an isolated digital I/O terminal		Not available
		Controller	DIO0808LY-USB by CONTEC Complies with USB2.0 HighSpeed(480Mbps) and USB1.1		
		USB port	Type B		
	PCR control		Turns off AC power supply output when over-heating protection is activated		Not available
	Output terminal	Mini-Din6P female			

Item		LIN1020JF	LIN3020JF	OP01-LIN1020JF
Control features	OP01-LIN1020JF control	Control output to the OP01-LIN1020JF, alarm input from the OP01-LIN1020JF	Not available	Control input from the LIN1020JF, alarm output to the LIN1020JF
	I/O terminal	Dsub25P		Dsub25P
	Protection functions	When abnormal resistor temperature is detected, the ALARM indicator lights, a make contact signal is transmitted to turn off (open) all phases at once. Cooling operation continues.		
	Operation when the control power supply turns off	All phase outputs are turned off (opened) at once.		
Cooling method		Forced air		
Control power supply	Nominal input rating	100 Vac to 240 Vac, 50 Hz/ 60 Hz, approx. 500 VA or less		
	Input voltage range	Within $\pm 10\%$ of the nominal input voltage rating		
	Input terminal	Terminal block, M4 screws		
Environmental conditions	Installation location	Indoors, altitude of up to 2000 m, overvoltage category II		
	Temperature and humidity range in which specifications are guaranteed	23 °C $\pm$ 5 °C (73.4 °F $\pm$ 41 °F)		
	Operating temperature and humidity range	0 °C to 50 °C (32 °F to 122 °F), 20 %rh to 80 %rh (no condensation)		
	Storage temperature and humidity range	-20 °C to 70 °C (-4 °F to 158 °F), 90 %rh or less (no condensation)		
Withstanding voltage	Control power supply input to case,	1.5 kVac for 1 minute		
Insulation resistance	Input to case, Output to case, Current monitor output to I/O	100 M $\Omega$ or greater at 500 Vdc		
External dimensions		See the outline drawing.		
Weight		Approx. 88 kg (194 lb)	Approx. 98 kg (216 lb)	Approx. 83 kg (183 lb)
Earth continuity	Protective conductor terminal to case	25 Aac 0.1 $\Omega$ or less (control power supply terminal) No damage at 40 Aac for 1 minute (protective ground terminal G of the I/O terminal)		
Safety		Complies with the requirements of the following standard. IEC61010-1:2001 (Class I <sup>3</sup> , Pollution degree 2 <sup>4</sup> )		
Accessories	Control cable	1 pc.		Not available
	Control board	1 card		Not available
	OP01-LIN1020JF Control cable	Not available		1 pc.
	Control power cable	1 pc.		
	Screws <sup>5</sup>	8 pcs.		
	Heavy object warning label	1 pc.		
	Operation Manual	1 copy		1 disc <sup>6</sup>
	CD-ROM API-USBP (WDM) driver software by CONTEC	1 disc		Not available

- 1 n: Harmonic (50 Hz fundamental frequency)
- 2 Between each of the internal sensing points and the OUTPUT terminal when using the sensing function of the PCR-LE or PCR-LE2 series AC power supplies
- 3 This product confirms to Class I. Be sure to ground the protective conductor terminal of this product. If not grounded properly, safety is not guaranteed.
- 4 Pollution is addition of foreign matter (solid, liquid or gaseous) that may produce a reduction of dielectric strength or surface resistivity. Pollution Degree 2 assumes that only non-conductive pollution will occur except for an occasional temporary conductivity caused by condensation.
- 5 Used when the rack mount bracket is removed
- 6 Accessory manual

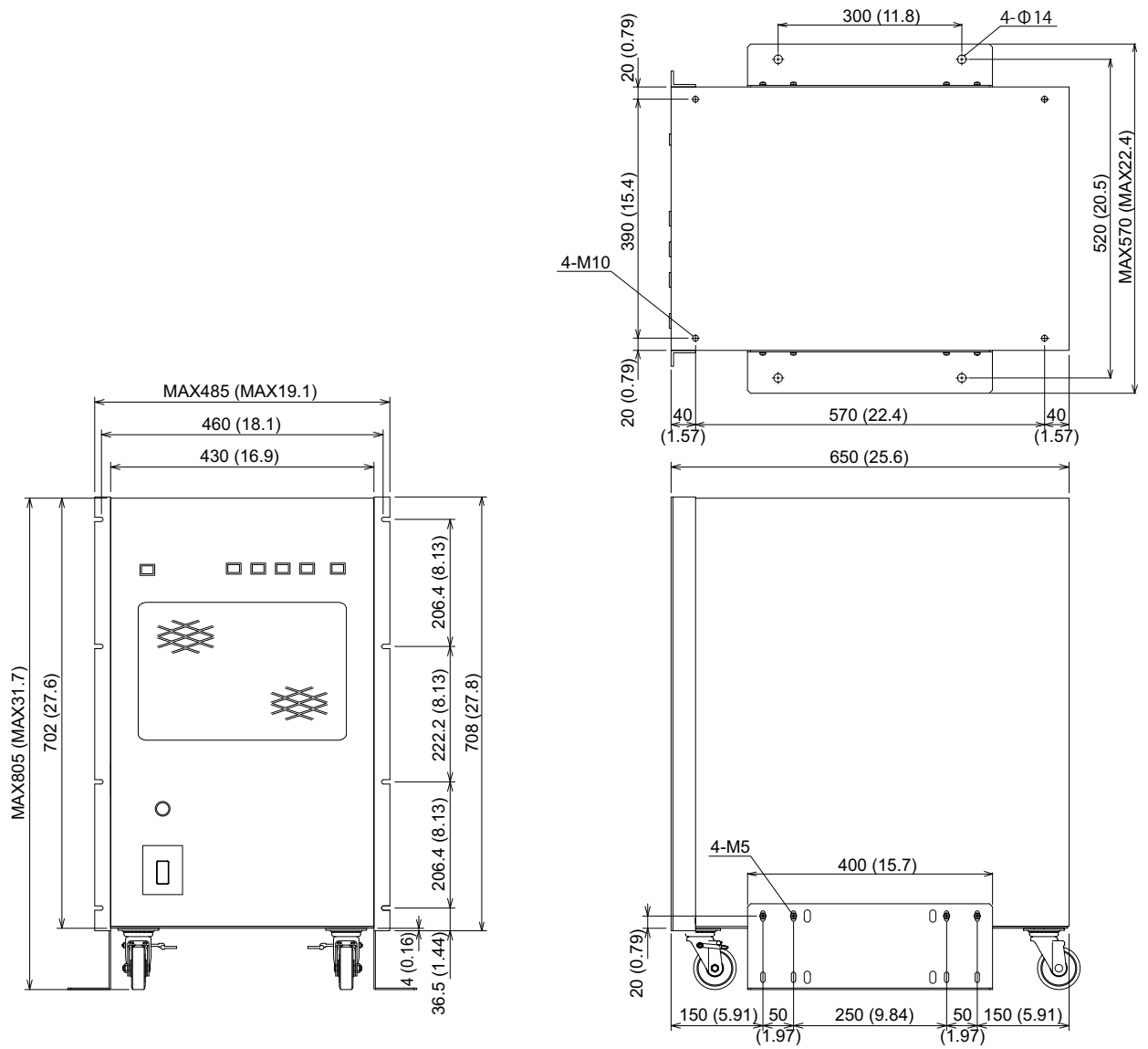

Unit: mm (inches)

LIN1020JF, LIN3020JF, OP01-LIN1020JF outline drawing

# Appendix A Troubleshooting

This section introduces troubleshooting measures. Check whether any of the items listed below apply to your case. If following the remedy does not solve your problem, contact your Kikusui agent or distributor.

Symptom	Inspection	Remedy	
Voltage is not applied to the EUT.	The product's POWER switch is turned off.	<ul style="list-style-type: none"> <li>Turn on the POWER switch.</li> </ul>	p. 48
	The AC power supply output is turned off.	<ul style="list-style-type: none"> <li>Turn on the AC power supply output.</li> </ul>	—
	The impedance is not selected.	<ul style="list-style-type: none"> <li>The impedance switches are not interlocked. Therefore, turn off all switches first, and then press the appropriate switch.</li> </ul>	p. 48
	The EXPAND terminals of the LIN1020JF and OP01-LIN1020JF are not connected with an OP01 control cable.	<ul style="list-style-type: none"> <li>Connect the EXPAND terminals of the LIN1020JF and OP01-LIN1020JF with an OP01 control cable.</li> </ul>	p. 24
Impedance cannot be selected from the front panel.	The product's remote control switch is turned on (the button is pressed in).	<ul style="list-style-type: none"> <li>Turn off the product's remote control switch (release the button).</li> </ul>	p. 52
The ALARM indicator is lit.	The product's ALARM indicator is lit.	<ul style="list-style-type: none"> <li>The temperature inside the product is too high. Allow the product to cool down adequately.</li> <li>Turn off the AC power supply output.</li> </ul>	p. 51
Remote control does not work.	The illumination area of the REMOTE switch on the front panel is turned off.	<ul style="list-style-type: none"> <li>Turn on the REMOTE switch on the front panel.</li> </ul>	p. 52
	The illumination area of the REMOTE switch on the front panel is turned on.	<ul style="list-style-type: none"> <li>Enable the remote signal.</li> <li>The product switches to remote control mode when the REMOTE switch is on and the remote signal is being received.</li> </ul>	p. 52
The impedance error is large.	The AC power supply sensing terminal is not connected or has become disconnected.	<ul style="list-style-type: none"> <li>Connect the AC power supply sensing terminal securely.</li> </ul>	p. 18

# Appendix B Connecting the PCR-LE and PCR-LE2

---

This section describes how to use the output terminal of the PCR-LE and PCR-LE2 AC power supplies. The following description is for connecting the AC power supplies to the LIN-JF. For other details, see the PCR-LE or PCR-LE2 manual.



## **Risk of electric shock.**

- **To prevent electric shock, be sure to attach the transparent cover on the rear panel of the AC power supplies. High voltage will be applied to the terminals.**
  - **Before you connect cables to the AC power supplies' OUTPUT terminal blocks, be sure to turn the POWER switch off, and then shut off the power supply from the switchboard.**
  - **Be sure to ground the AC power supplies to prevent electric shock.**
  - **Never connect the INPUT terminal block of the LIN-JF to the AC line. The internal circuit of the LIN-JF is not designed to be connected to the AC line.**
  - **Fasten the terminal screws securely. Loose screws are dangerous because the cables may come loose or the connection may heat up.**
-

## Output terminal

The screw size of the output terminal block varies depending on the model.

Model	Terminal block screw size
	Single-phase output
PCR1000LE	M4
PCR2000LE	M4
PCR3000LE	M5
PCR4000LE	M5
PCR6000LE	M6
PCR9000LE	M6

### Single-phase two-wire output

#### 1 Pull out the OUTPUT Terminal block from the bottom of the AC power supply's rear panel.

To connect cables to the OUTPUT terminal block of the AC power supply (PCR-LE and PCR-LE2 series except the PCR500LE), the terminal block tray needs to be pulled out. For details, see the manual supplied with the AC power supply.

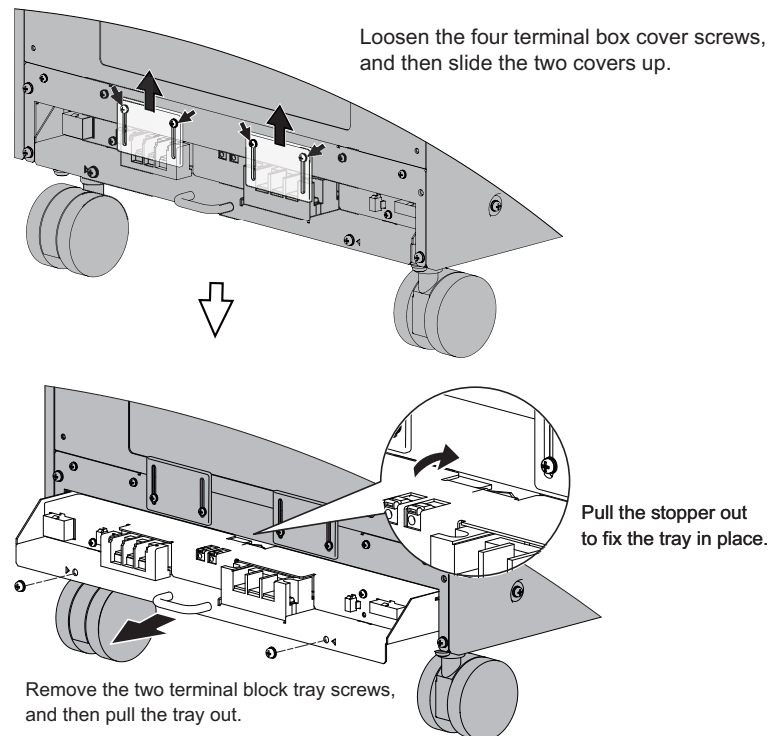



## 2 Connect the AC power supply's OUTPUT Terminal to the LIN-JF input terminal.

The following figures show a connection example.

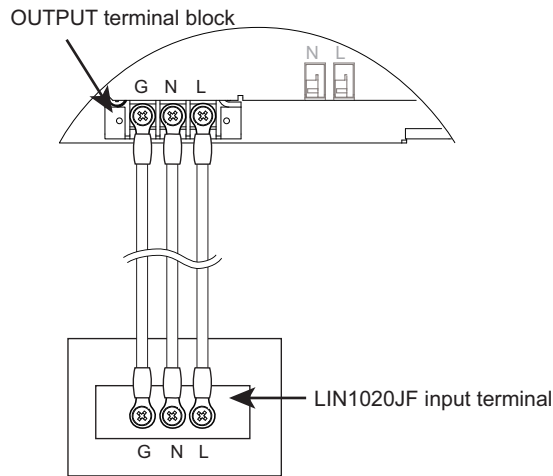

## Sensing

The sensing functions that are equipped in the PCR-LE and PCR-LE2 series can be used to reduce the effects of output terminal wiring impedance. This simplifies the wiring when they are incorporated in the test system.

Screw-less terminals are used.

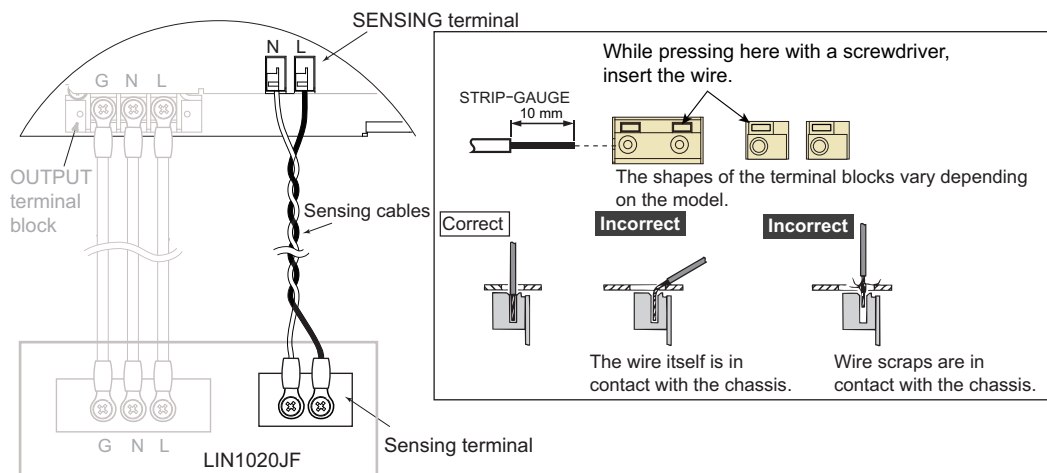

This section describes the PCR6000LE2 and PCR9000LE2. For details on the PCR27000LE2, see the PCR-LE2 series AC power supply setup guide or user's manual.

## Output terminal

The screw size of the output terminal block varies depending on the model.

Model	Terminal block screw size		
	Single-phase output	Single-phase three-wire output	Three-phase output
PCR6000LE2	M8	M5	M5
PCR9000LE2	M8	M5	M5
PCR27000LE2	M8	M8	M8

### Single-phase two-wire output

- 1 Pull out the OUTPUT Terminal block from the bottom of the AC power supply's rear panel.**

To connect cables to the OUTPUT terminal block of the AC power supply, the terminal block tray needs to be pulled out. Loosen the six terminal box cover screws, and then slide the three covers up.

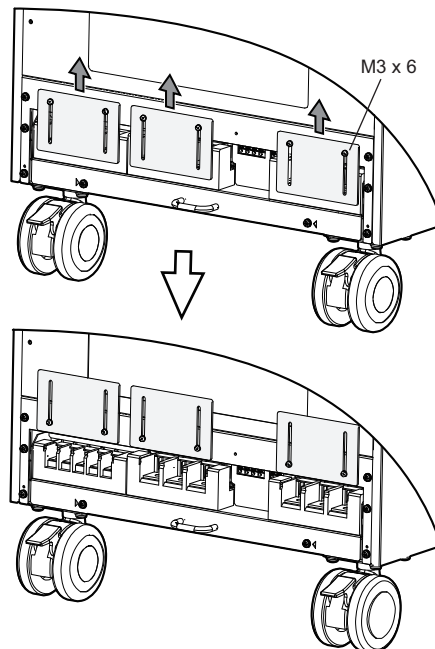

- 2 Remove the two terminal block tray screws, and then pull the tray out.** Pull out the stopper to lock the terminal block tray in place.

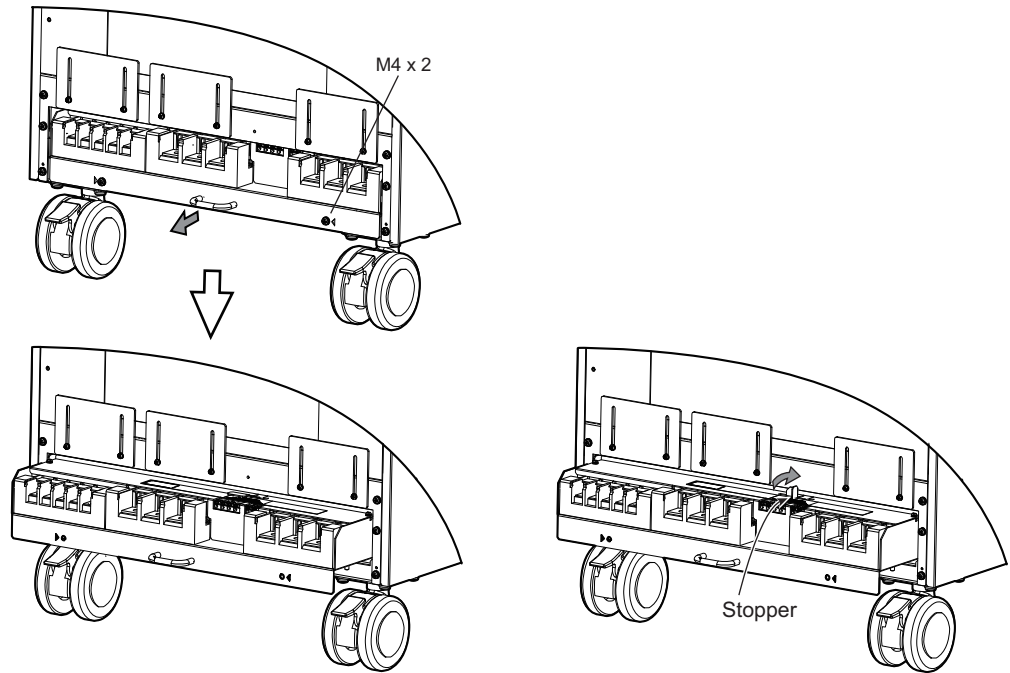

**3 Connect the AC power supply's OUTPUT Terminal to the LIN-JF input terminal.**

The connection to the AC power supply OUTPUT terminal is shown in a figure on the next page.

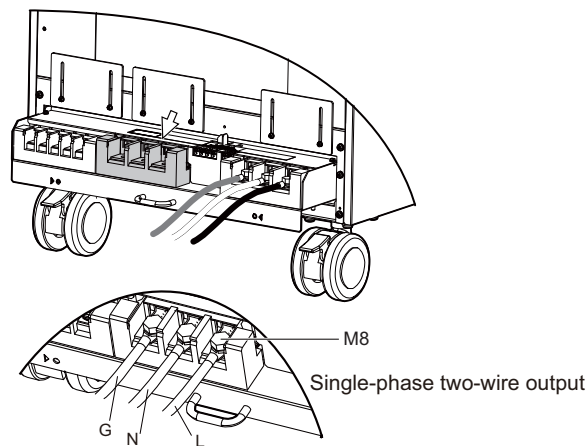

**Single-phase three-wire, three-phase three-wire, and three-phase four-wire output**

**1 Pull out the OUTPUT Terminal block from the bottom of the AC power supply's rear panel.**

The procedure for pulling out the OUTPUT terminal block is the same as with the single-phase two-wire output terminal.

**2 Connect the AC power supply's OUTPUT Terminal to the LIN-JF input terminal.**

The connection to the AC power supply OUTPUT terminal is shown in the figure below.

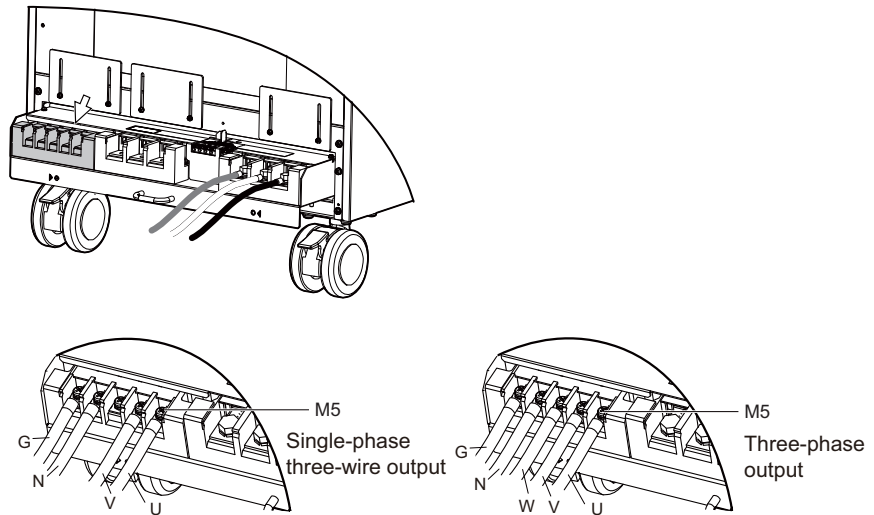

## Sensing

See p. 65

The sensing functions that are equipped in the PCR-LE and PCR-LE2 series can be used to reduce the effects of output terminal wiring impedance. This simplifies the wiring when they are incorporated in the test system.

Screw-less terminals are used (the same as with the PCR-LE AC power supplies).

The figure below shows wiring examples for a single-phase two-wire circuit and three-phase four-wire circuit.

### Single-phase two-wire circuit

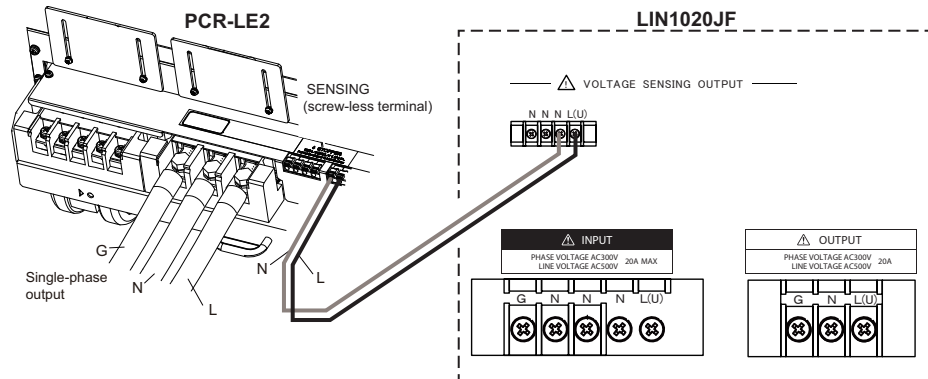

### Three-phase four-wire circuit

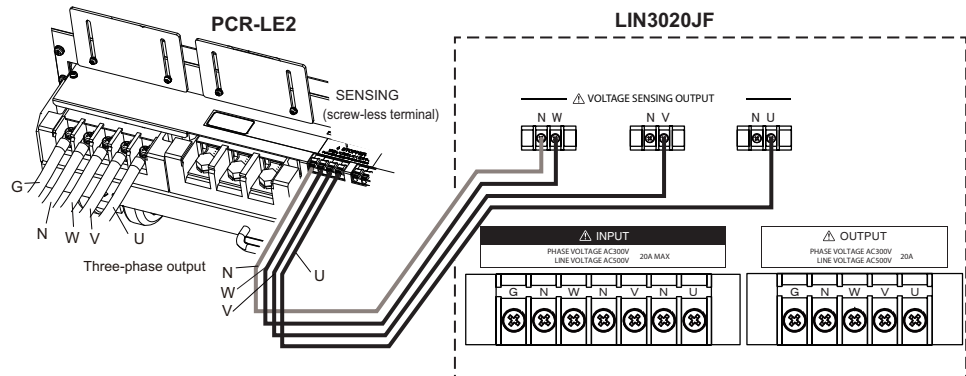

# Appendix C KHA3000 Input Terminal

This section describes how to use the KHA3000 input terminal. One phase (input channel) is described. For details on each phase, see the KHA3000 operation manual.

## Voltage input terminal

Use input terminal V and input terminal  $\pm$  to connect to the EUT. We recommend that you use UL1015 wires or equivalent with a wire size of AWG18. Strip 10 mm of insulation. To secure the wires in place, use the screwdriver supplied with the KHA3000 to fasten the terminal screws. Twist the wires as much as possible.

## Current input terminal

There are SOURCE and LOAD terminals. Connect the SOURCE terminal to the impedance output and the LOAD terminal to the EUT.

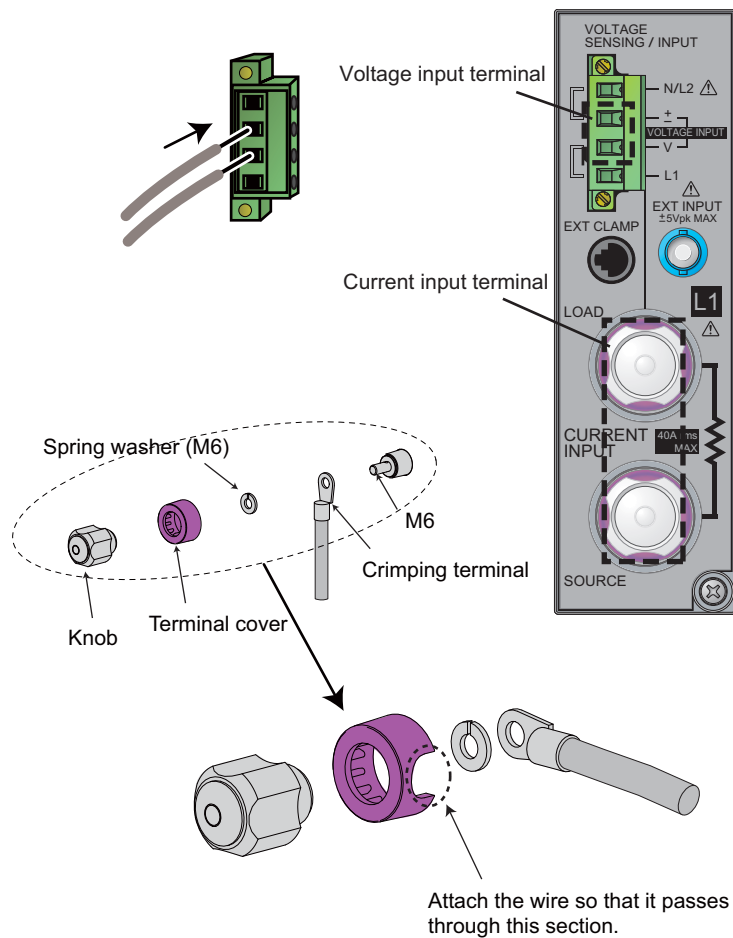

## Delta transformation (star-delta transformation)

The delta transformation feature is used to convert phase voltage measurements of three-phase four-wire circuits to line voltages. Therefore, even if the actual circuit is wired using a three-phase four-wire system, line voltage measurement of a three-phase three-wire system is possible. The following figure shows a three-phase three-wire circuit and three-phase four-wire circuit used to test a three-phase three-wire EUT.

You can set the delta transformation from the wiring system menu. For details, see the KHA3000 operation manual.

Three-phase three-wire circuit

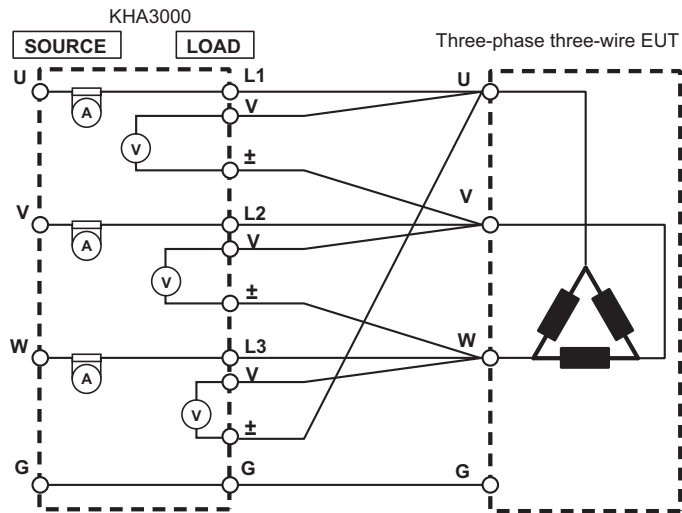

Three-phase four-wire circuit

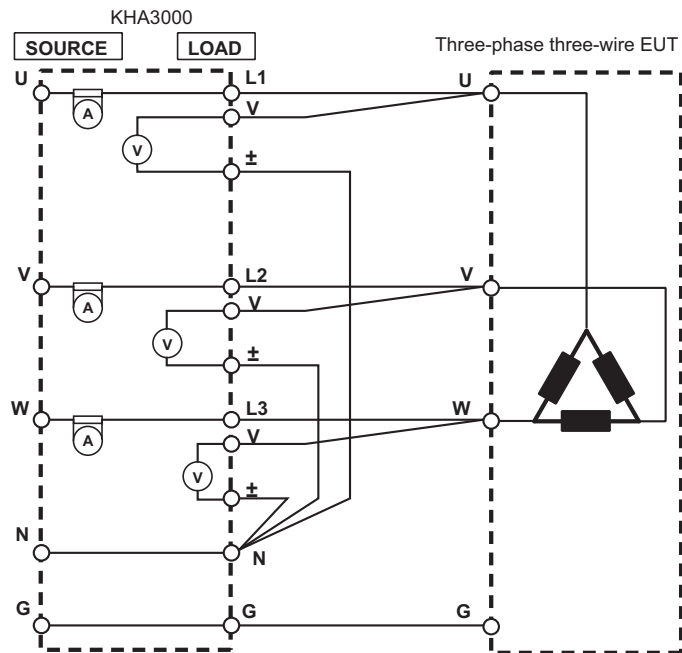

# Index

<b>A</b>	
AC INPUT .....	15, 16, 17, 18
AC power supplies that can be used .....	21
ALARM indicator .....	15, 16, 17
<b>B</b>	
base hold angle .....	7
BYPASS .....	15, 16, 17, 53
<b>C</b>	
caster lock lever .....	7
contact signal control, example .....	54
CONTROL INPUT .....	15, 16, 19
<b>D</b>	
delta transformation (star-delta transformation) .....	70
driver, installation .....	56
<b>E</b>	
EXPAND .....	15, 17
EXPAND terminal .....	19, 24
external dimensions .....	60
eye bolt screw hole .....	8
<b>I</b>	
impedance, selecting .....	48
INPUT .....	15, 16, 17
<b>L</b>	
LIN OVERHEAT (overheat alarm) .....	54
<b>O</b>	
operating temperature and humidity range .....	60
OUTPUT .....	15, 16, 17
overheat alarms, handling .....	51
<b>P</b>	
parts to have ready .....	21
PCR CONTROL .....	15, 16, 19
POWER switch .....	15, 16, 17
<b>R</b>	
REMOTE .....	15, 16, 17, 53
remote control, switching .....	52
<b>S</b>	
sensing .....	18, 65, 68
STATUS OUTPUT .....	15, 16, 19
storage temperature and humidity range .....	60
<b>T</b>	
temperature range in which specifications are guaranteed .....	60
test circuit .....	21
<b>U</b>	
USB .....	15, 16
USB port .....	19, 55
<b>V</b>	
VOLTAGE SENSING OUTPUT .....	15, 16, 17, 18
<b>Z</b>	
Z1 .....	15, 16, 17, 53
Z2 .....	15, 16, 17, 53
Z3 .....	15, 16, 17, 53



**环境保护使用期限**  
**Environment-friendly Use Period**

该标记为适用于在中华人民共和国销售的电子信息产品的环境保护使用期限。

只要遵守有关该产品的安全及使用注意事项，从制造年月起计算，在该年度内，就不会对环境污染、人身、财产产生重大的影响。

产品的废弃请遵守有关规定。

产品的制造年月可以在以下网址中确认。

<http://www.kikusui.co.jp/pi/>

**有毒有害物质或元素名称及含有标示**  
**Name of hazardous materials and symbol of element in the equipment and quantity**

部件名称	有毒有害物质或元素					
	铅 Pb	汞 Hg	镉 Cd	六价铬 Cr(VI)	多溴联苯 PBB	多溴二苯醚 PBDE
印刷电路板组装机	×	○	×	○	○	○
内部接线	×	○	×	○	○	○
外壳	×	○	×	○	○	○
底盘组装机 (含变压器)	×	○	×	○	○	○
辅助设备	×	○	×	○	○	○

本表格依据SJ/T 11364 的规定编制。

○：该部件所有均质材料的有毒有害物质的含量不超过GB/T 26572 标准所规定的极限值要求。

×：该部件至少有一种均质材料的有毒有害物质的含量超过GB/T 26572标准所规定的极限值要求。





If you find any misplaced or missing pages in the manuals, they will be replaced. If the manual gets lost or soiled, a new copy can be provided for a fee. In either case, please contact your Kikusui agent or distributor. At that time, inform your agent or distributor of the "Part No." written on the front cover of this manual.

Every effort has been made to ensure the accuracy of this manual. However, if you have any questions or find any errors or omissions, please contact your Kikusui agent or distributor.

After you have finished reading this manual, store it so that you can use it for reference at any time.

## KIKUSUI ELECTRONICS CORP.

---

1-1-3 Higashiyamata, Tsuzuki-ku, Yokohama,  
224-0023, Japan  
Tel: +81-45-593-7570 Fax: +81-45-593-7571



Website

<http://www.kikusui.co.jp/en>