



KIKUSUI

Part No. IB026683

Jun. 2015

Operation Manual

Line Impedance Network

LIN3060J

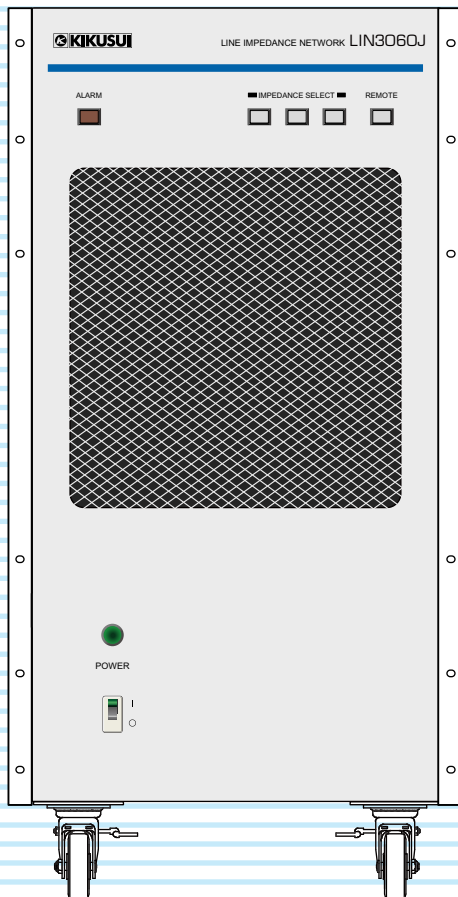

1 General Description

2 Description of Parts

3 Wiring the Test System

4 Operation

5 Remote Control

6 Specifications

Appendix

Thank you for purchasing the LIN3060J Line Impedance Network.

About the Manuals

This manual provides an overview of the product and notes on usage. It also explains how to configure it, operate it, perform maintenance on it, and so on.

This manual only provides general information about the AC power supplies (PCR-LE, PCR-LE2, PCR-LA, and PCR-L series) that are used in combination with this product. For details on the AC power supplies, see the operation manual provided with the respective product.

You can download the most recent version of these manuals from the Kikusui Electronics Corporation website (<http://www.kikusui.co.jp/en/download/>).

Target audience of these manuals

This operation manual is intended for users who will use the LIN3060J Line Impedance Network. It is also intended for instructors who will teach these users.

Explanations are given under the presumption that the reader has knowledge of the electrical aspects of line impedance networks.

How to read this manual

This manual is designed to be read from beginning to end. We recommend that you read it thoroughly before using this product for the first time.

Copyrights

The contents of this manual may not be reproduced, in whole or in part, without the prior consent of the copyright holder.

The specifications of this product and the contents of this manual are subject to change without prior notice.

Copyright © 2014 Kikusui Electronics Corporation

Notations used in this guide

- In this manual, the LIN3060J Line Impedance Network is also referred to as the LIN3060J.
- In this manual, the following AC power supplies are also referred to collectively as the AC power supply.
PCR-LE Series
PCR-LE2 Series
PCR-LA Series
PCR-L Series
- The term “PC” is used to refer generally to both personal computers and workstations.
- This manual refers to each phase of a wiring system as U phase, V phase, W phase, and N phase. These phases correspond respectively to the R, S, T, and N phases used in other manufacturers' products.
- The following markings are used in the explanations in this manual.



Indicates a potentially hazardous situation which, if ignored, could result in death or serious injury.



Indicates a potentially hazardous situation which, if ignored, may result in damage to the product or other property.



Indicates information that you should know.



Explanation of terminology or operation principle.



Indicates a reference to detailed information.

Contents

Notations used in this guide	2
Checking the package contents	5
Options	5
Safety markings	6
Safety precautions	6
Precautions when choosing the installation location	7
Precautions for moving the product	7
1 General Description	
Product Features	8
Impedance Construction	9
Overview of the Test System	10
Grid-connected device test system	10
Device test system	11
2 Description of Parts	
Front Panel	13
Rear Panel	14
INPUT and OUTPUT terminals	15
VOLTAGE SENSING OUTPUT terminal (for the PCR-LE and PCR-LE2)	15
CT OUTPUT terminal (current monitoring)	15
AC INPUT (control power supply input terminal)	16
PCR CONTROL terminal	16
CONTROL INPUT and STATUS OUTPUT terminals	17
USB port	17
3 Wiring the Test System	
Removing the Terminal Cover	18
Connecting the Control Power Cable	18
Wiring the Test Circuit	19
Single-phase One PCR-LE	20
Single-phase, Single-phase Three-wire Two PCR-LEs	22
Single-phase, Three-phase Three PCR-LEs	24
Single-phase One PCR-LE2	26
Single-phase, Three-phase One PCR-LE2	28
Connecting the Control Terminals	30
Connecting the PCR CONTROL terminal	30
4 Operation	
Powering On	32
Turning on the POWER switch	32
If the INPUT VOLTAGE (supply voltage) selector is set incorrectly	32
Panel Operation	33
Selecting the impedance	33
Configuring the AC Power Supplies (PCR-LE and PCR-LE2)	34
Setting hardware sensing	34
Setting the response	34
Output current limit of the AC power supplies	34
Power level supplied from the test circuit to the EUT	34
Configuring the KHA3000	35
Handling Overheat Alarms	35
5 Remote Control	
Switching to Remote Control Mode	36
Switching between panel control and remote control	36
Controlling the Product Using Contact Signals	37
CONTROL INPUT terminal	37
STATUS OUTPUT terminal	37
Example of contact signal control	38
Controlling the Product Using USB	39
USB port	39
Installing the driver	40
Checking the feature	40
6 Specifications	
Appendix A	
Troubleshooting	46
Appendix B	
Connecting the PCR-LE and PCR-LE2	47
PCR-LE	48
Output terminal	48
Sensing	49
PCR-LE2	50

Output terminal50
Sensing52

Appendix C

KHA3000 Input Terminal . 53

Delta transformation (star-delta transformation)54



Checking the package contents

When you receive the product, check that all accessories are included and that the accessories have not been damaged during transportation. If something is damaged or missing, contact your Kikusui agent or distributor.

We recommend that you save all packing materials, in case the product needs to be transported at a later date.

• Accessories



- Control cable (1 pc.)
[3m] [85-50-0390]

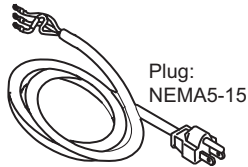

- Control power cable (1 pc.)
[3m] [85-10-0650]

For nominal power supply voltages 100 V and 120 V

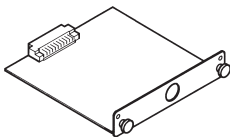

- Control board (1 card)
[UA-1894-01]

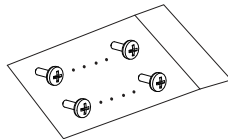

- Screws (12 pcs.)

Use these when the rack mount bracket is removed.

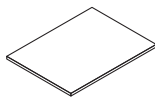

- Operation manual (1 copy)

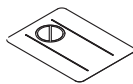

- Heavy object warning label (1 pc.)
[A8-900-158]

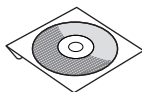

- CD-ROM (1 disc)
API-USBP (WDM) driver software by CONTEC

Supplied with models with the USB interface option

Options

The following options can be used with this product.

• USB interface (factory option)

You can use the USB port to remotely control the product. The DIO-0808LY-USB Isolated Digital I/O Terminal for USB2.0 made by CONTEC is used as the control device.

• Control power cable (heavy PVC jacketed three-core)

Cable for connecting to the control power supply input (AC INPUT) terminal on the rear panel of the product.

Model: AC5.5-3P3M-M4C

Type: Heavy PVC jacketed

three-core cable

Length: 3 m

Nominal cross-sectional area: 5.5 mm² (AWG10 equivalent)

Crimping terminal size: M4



For nominal power supply voltages 200 V and 240 V

Safety markings

For the safe use and safe maintenance of this product, the following symbols are used throughout this manual and on the product. Note the meaning of each of the symbols to ensure the safe use of the product. (Some symbols are not used depending on the product.)



Indicates that a high voltage (over 1000 V) is used here.

Touching an area marked with this symbol without taking proper precautions may cause a fatal or serious electric shock. If you must touch an area marked with this symbol, ensure that the area is safe before you do so.

DANGER Indicates an imminently hazardous situation which, if ignored, will result in death or serious injury.



WARNING

Indicates a potentially hazardous situation which, if ignored, could result in death or serious injury.



CAUTION

Indicates a potentially hazardous situation which, if ignored, may result in damage to the product and other property.



Indicates a prohibited act.



Indicates a warning, caution, or danger. When this symbol is marked on the product, see the relevant section in this manual.



Indicates that parts will become hot. When this symbol is marked on the product, see the relevant section in this manual.



Protective conductor terminal.



Chassis (frame) terminal.



On (power supply).



Off (power supply).



In position of a bi-stable push control.



Out position of a bi-stable push control.

Safety precautions

The following safety precautions must be observed to avoid fire hazards, electric shock, accidents, and device failures. Keep them in mind and make sure to observe them.

Using the product in a manner that is not specified in this manual may impair the protection functions provided by the product.

Users



- This product must be used only by qualified personnel who understand the contents of this operation manual.
- If unqualified personnel are to use the product, be sure the product is handled under the supervision of qualified personnel (those who have electrical knowledge). This is to prevent the possibility of personal injury.



Purpose of use

- Never use the product for purposes other than the product's intended use.
- Do not connect electrical appliances that are normally used with commercial power supplies as the PCR-LE Series load.
- This product is not designed or manufactured for general home or consumer use.

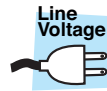

Input power

- Always use the product within the rated input line voltage range.
- Use the power cable provided to apply power. For details, see the appropriate pages in this manual.
- This product conforms to IEC Overvoltage Category II (energy-consuming equipment that is supplied from a fixed installation).



Cover

- Some parts inside the product are hazardous. Do not remove the external cover.



Grounding

- This product conforms to IEC Safety Class I (equipment that has a protective conductor terminal). To prevent electric shock, be sure to connect the protective conductor terminal of the product to electrical ground (safety ground).



Operation

- If you notice a malfunction or abnormality in the product, stop using it immediately, and remove the power cable plug from the outlet or remove the power cable from the switchboard. Make sure the product is not used until it is completely repaired.
- Make sure to use output cables, load cables, and other cables that run current have sufficient current capacity.
- Do not disassemble or modify the product. If you need to modify the product, contact your Kikusui agent or distributor.



Maintenance, Inspection and Calibration

- To maintain the performance and safe operation of the product, we recommend periodic maintenance, inspection, cleaning, and calibration.
- To prevent the possibility of electric shock, remove the power plug from the outlet, or turn off the switchboard before carrying out maintenance or inspection. Do not remove the external cover.
- Check periodically that there are no tears or breaks in the power cable.
- If the panel needs cleaning, gently wipe it using a soft cloth with water-diluted neutral detergent. Do not use volatile chemicals such as benzene or thinner.
- To maintain the impedance characteristics of the product, inspect the relay periodically and check that the relay contact resistance is sufficiently small. Depending on the result of an inspection, the relay may need to be replaced.
- The product is calibrated before shipment. To maintain long-term performance, we recommend periodic calibration. To have your product calibrated, contact your Kikusui distributor or agent.



Service

- Kikusui service engineers will perform internal service on the product. If the product needs adjustment or repairs, contact your Kikusui agent or distributor.

Precautions when choosing the installation location

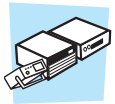

Be sure to observe the following precautions when installing the product.

- **Do not use the product in a flammable environment.**
Risk of explosion or fire. Do not use the product near alcohol, thinner, or other combustible materials, or in an environment containing such vapors.
- **Avoid locations where the product is exposed to high temperatures or direct sunlight.**
- **Do not install the product near a heater or in areas subject to drastic temperature changes.**
The product's operating temperature range is 0 °C to 50 °C.
- **Avoid humid environments.**
Do not install the product in high-humidity locations, such as near a boiler, humidifier, or water supply. Condensation may form even within the operating humidity range. If this happens, do not use the product until the condensation dries up completely.
The product's operating humidity range is 20 %rh to 80 %rh (no condensation).
- **Be sure to use the product indoors.**
This product is designed for safe indoor use.
- **Do not install the product in a corrosive environment.**
Do not install the product in a corrosive atmosphere or in an environment with a high level of sulfuric acid mist or other types of poisonous gas. Doing so may damage the terminals or cause the internal conductors to corrode. This can lead to malfunction, damage to the product, or fire.
- **Do not install the product in a dusty location.**
Accumulation of dust can lead to electric shock or fire.
- **Do not use the product in a poorly ventilated location.**
Secure adequate space around the product so that air can circulate around it.
Allow at least 50 cm of space between the air inlet/outlet and the wall (or obstacles).
- **Do not place objects on top of the product.**
Placing objects (especially heavy ones) on top of the product can lead to malfunctions.
- **Do not use the product in a location subject to strong magnetic or electric fields or in a location where the input power supply signal contains large amounts of distortion or noise.**
Doing so may cause the product to malfunction.
Noise generated by this product may affect other devices.
- **Use the product in an industrial environment.**
Using this product in a residential area may interfere with radio and TV broadcast reception.
In such case, users may need to take special measures to reduce the electromagnetic radiation.
- **Affix the heavy object warning label.**
Affix the heavy object warning label to the product where it can be readily seen. The charger weighs approximately 170 kg (375 lbs).

- **Do not install the product on an inclined surface or in a location subject to vibrations.**
The product may fall or tip over and cause damage and injury.
- **Lock the casters.**
Use the caster lock levers to lock the casters.

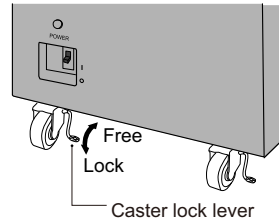

- **Use the base hold angles.**
To prevent the product from falling over, use the base hold angles to fix the product to the installation location.

When the product is shipped from the factory, base hold angles are attached to the left and right sides of the bottom of the product.

Remove the base hold angles from the product.

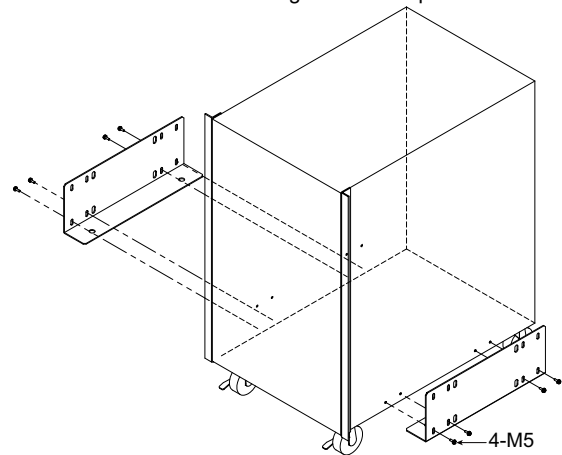

Face the base hold angles away from the product, and fix them in place using the screws that you removed.

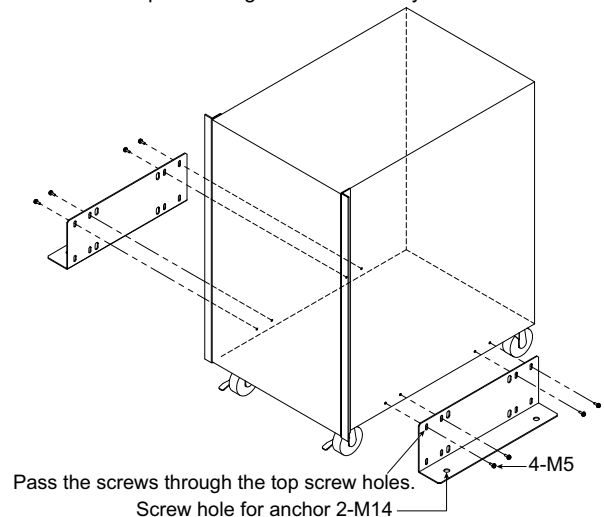

Pass the screws through the top screw holes.

Screw hole for anchor 2-M14

Precautions for moving the product



Note the following points when moving the product to the installation location or when transporting the product.

- **Turn off the POWER switch.**
Moving the product with the POWER switch turned on may cause electric shock or damage to the product.
- **Remove all wiring.**
Moving the product with the cables connected may cause wires to break or injuries due to the product falling over.
- **Remove the base hold angles.**
Remove the base hold angles or return them to the factory default condition.

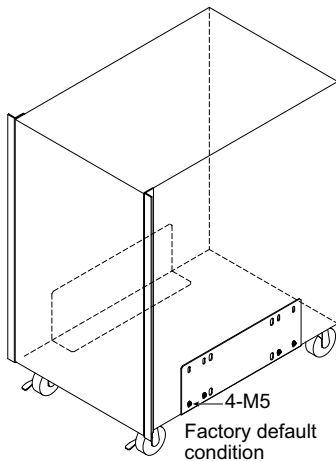

- **Unlock the casters.**
Use the caster lock levers to unlock the casters. Moving the product without releasing the lock may cause injuries due to the product falling over. Move the product over a surface that is as flat as possible.
- **Do not move the product by yourself.**
Be sure to have two or more people move the product. Exercise special care when carrying the product over a slope or across steps.
Check the weight that is indicated on the heavy object warning label that you affixed at the time of installation.
If you are using a forklift, be sure to slide the forks under the bottom of the product, check that the product is stable, and then raise the product.
If you are using a band or similar item to raise the product with a crane, be sure to slide the band under the bottom of the product, check that the product is stable, and then raise the product. There are four M10 eye bolt screw holes on the top of the product.
When you move the product, do not tip the product on its side or turn it upside down.
- **When transporting the product, be sure to use the original packing materials.**
Otherwise, damage may result from vibrations or from the product falling during transportation.
- **Be sure to include this manual.**

1 General Description

This chapter describes the product's impedance features and impedance construction and provides an overview of the test system.

Product Features

This product contains impedances required for testing grid-connected power conditioners as defined in the applicable JIS/JET standards. It is a reference impedance unit necessary for constructing a JETGR0002-1-2.0 grid-interconnection test system.

- **Support for different wiring systems by impedance elements**

Impedance elements support single-phase two-wire, single-phase three-wire, three-phase three-wire, and three-phase four-wire systems. The rated current of each phase is 60 A.

- **Impedance bypass function**

Impedance elements can be shorted if they are not necessary such as in the AC voltage tracking tests and frequency tracking tests of grid-connected device testing.

- **Designed specifically for JIS and JET standards**

This product contains impedances required for testing grid-connected power conditioners as defined in the applicable JIS/JET standards.

- **Support for PCR-LE, PCR-LE2, PCR-LA, and PCR-L series**

This product can be used in combination with the conventional PCR-L and PCR-LA series as well as the PCR-LE and PCR-LE2 series. The sensing functions that are equipped in the PCR-LE and PCR-LE2 series can be used to reduce the effects of wiring impedance. This simplifies the wiring when they are incorporated in the test system.

- **CT output terminal**

The product is equipped with current transformers (CTs) for detecting current in each phase. Voltage output proportional to the current can be obtained.

- **Communication function**

The available contact signal input terminal can be used to remotely control impedance selection. Remote control using USB is also available as a factory option.

Impedance Construction

This product's impedance consists of resistance, inductance, and short-circuit switch for each phase. The N phase impedance has a switch for selecting between resistance and inductance.

The following tables contain the defined resistance and inductance values for the U, V, W, and N phases. The impedances made up of these components are generally referred to as Z1 and Z2.

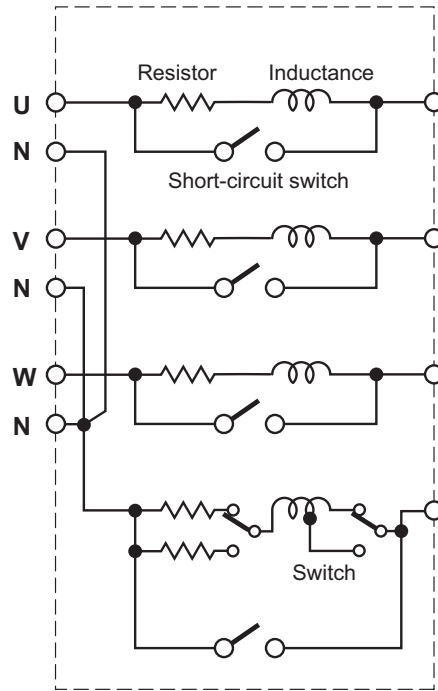

Phase	Z1	Z2	BYPASS
U	$0.19 \Omega + 0.23 \text{ mH}$	$0.19 \Omega + 0.23 \text{ mH}$	Impedance element shorted
V	$0.19 \Omega + 0.23 \text{ mH}$	$0.19 \Omega + 0.23 \text{ mH}$	
W	$0.19 \Omega + 0.23 \text{ mH}$	$0.19 \Omega + 0.23 \text{ mH}$	
N	$0.21 \Omega + 0.14 \text{ mH}$	$0.19 \Omega + 0.23 \text{ mH}$	

Overview of the Test System

The test system can be divided into the following two categories depending on the EUT.

- A test system for devices that connect to an AC power line and consume its power or regenerate power to the line. Power conditioners and the like are applicable for this test system. This manual refers to this test system as a grid-connected device test system.
- A test system for devices that connect to an AC power line and consume its power. General devices are applicable for this test system. This manual refers to this test system as a device test system.

This product is a component of the above-mentioned test systems and is referred to as the reference impedance or line impedance. The test systems have single-phase two-wire, single-phase three-wire, three-phase three-wire, and three-phase four-wire circuits for the different wiring systems.

Grid-connected device test system

This section provides a typical example of a grid-connected device test system using this product.

Three-phase 6 kVA: JIS/JET grid-interconnection test

Component	Model and function
AC power supply	Three PCR2000LEs
Impedance	LIN3060J
Power analyzer	KHA3000 (40 Amax/phase: external current sensor is used for 40 A and higher)
LCD load	—
Motor load	—
DC power supply	—

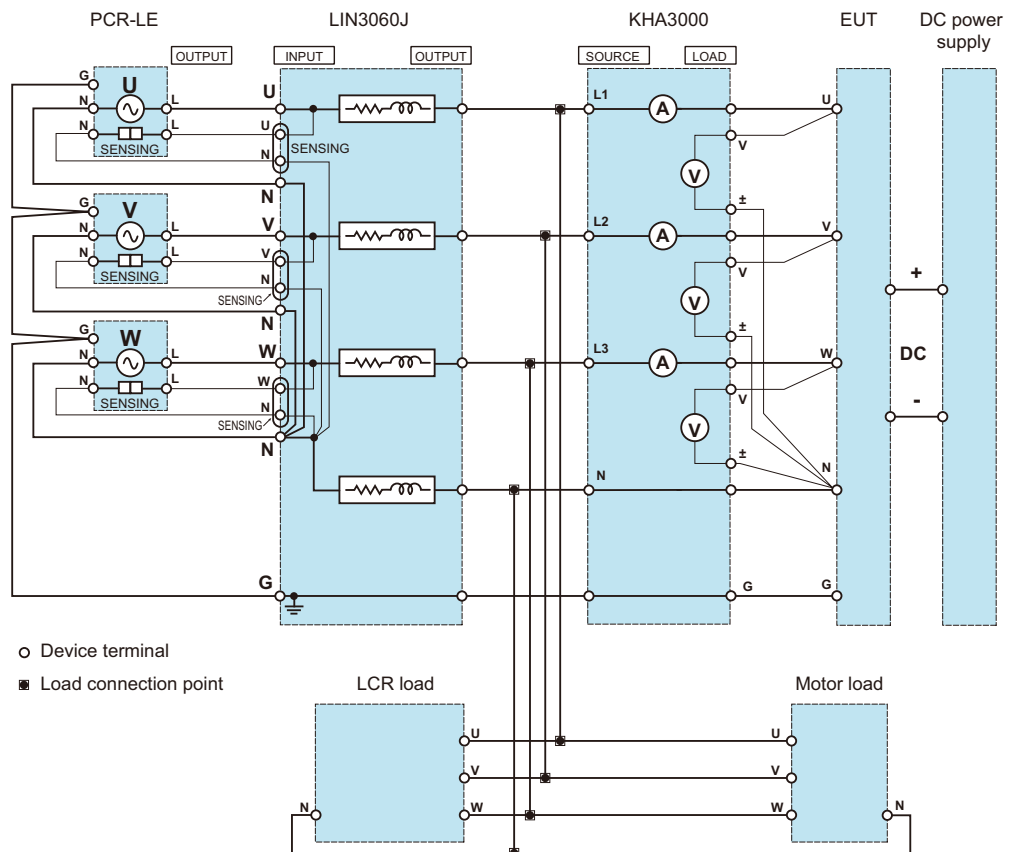

Device test system

This section provides a typical example of a device test system using this product.

Single-phase 4 kVA: JIS harmonic test

Component	Model and function
AC power supply	PCR4000LE
Impedance	LIN3060J The use of impedance is optional for JIS C61000-3-2 (2005) and later. The BYPASS function is used on the LIN3060J. Z1: For single-phase two-wire circuits Z2: For single-phase three-wire circuits
Power analyzer	KHA3000

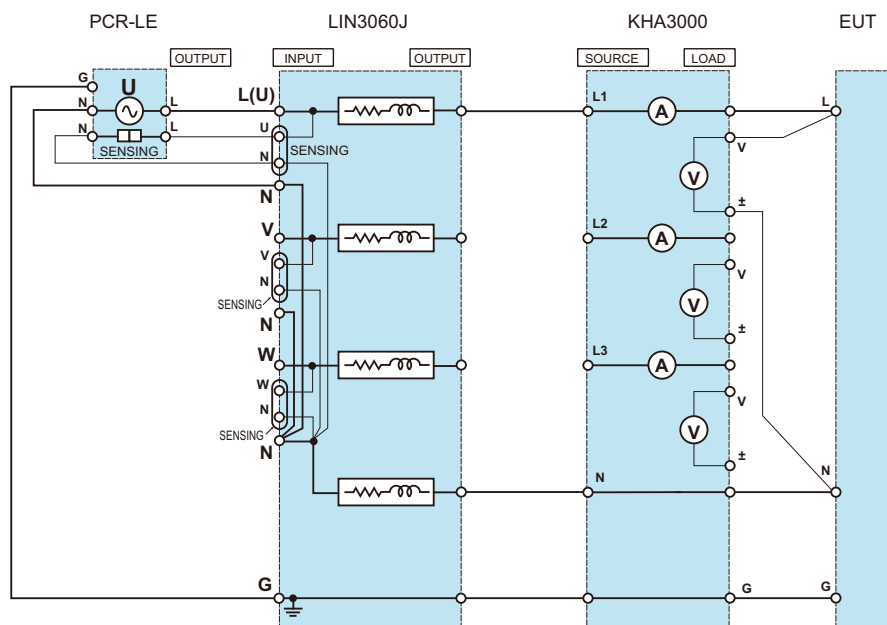

Single-phase 2 kVA and three-phase 6 kVA: harmonic test

Component	Model and function
AC power supply	Three PCR2000LEs
Impedance	LIN3060J The use of impedance is optional for JIS C61000-3-2 (2005) and later. The BYPASS function is used on the LIN3060J. Z1: For single-phase two-wire circuits and three-phase circuits Z2: For single-phase three-wire circuits and three-phase circuits
Power analyzer	KHA3000

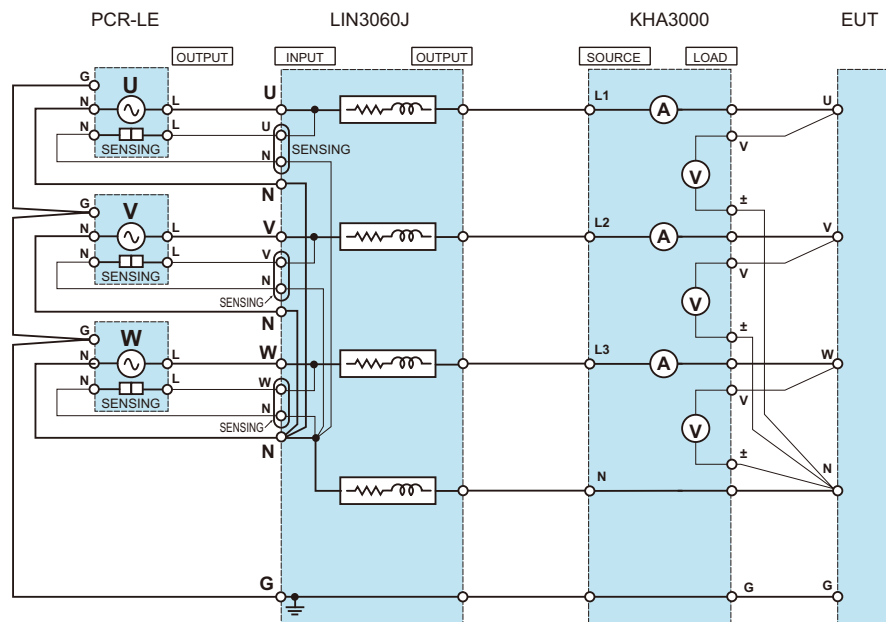

This page has been intentionally left blank.



2 Description of Parts

See p.49, p.55

This chapter explains the details of the product's parts. The descriptions of how to prepare the system components, namely the PCR-LE, PCR-LE2, and KHA3000, are provided in the appendixes.

Front Panel

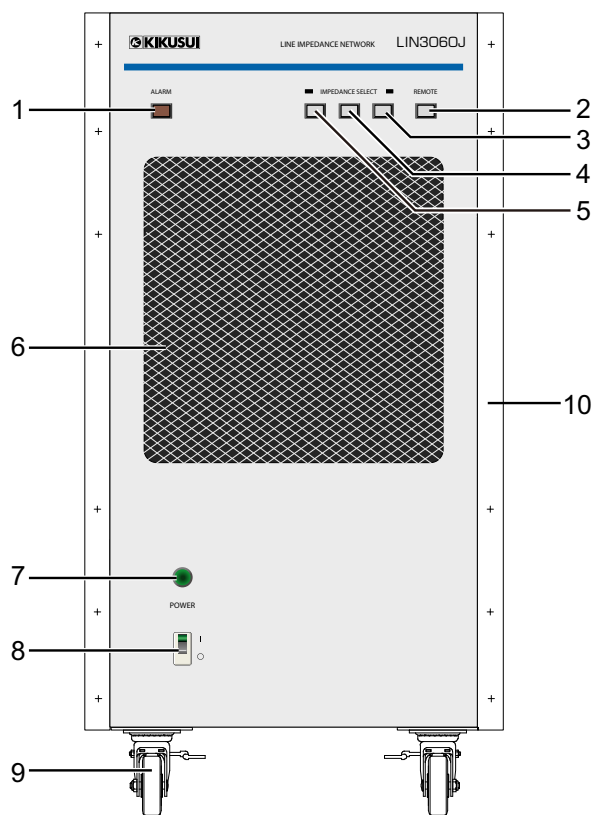

No.	Name	Function
1	ALARM indicator	Lights when the internal overheat alarm occurs
2	REMOTE	Remote control switch (illuminated type)
3	BYPASS	Impedance bypass switch (illuminated type)
4	Z2	Z2 impedance switch (illuminated type)
5	Z1	Z1 impedance switch (illuminated type)
6	Air inlet	Air inlet for internal cooling
7	Power indicator	Lights when the POWER switch is turned on
8	POWER switch	Power switch for the control power supply
9	Caster	Caster with a lock
10	Rack mount bracket	L-shaped bracket for mounting the product on a rack

Rear Panel

See p.20

This section describes the rear panel of the product. For details on how to wire the product to other system components, see “Wiring the Test System”.

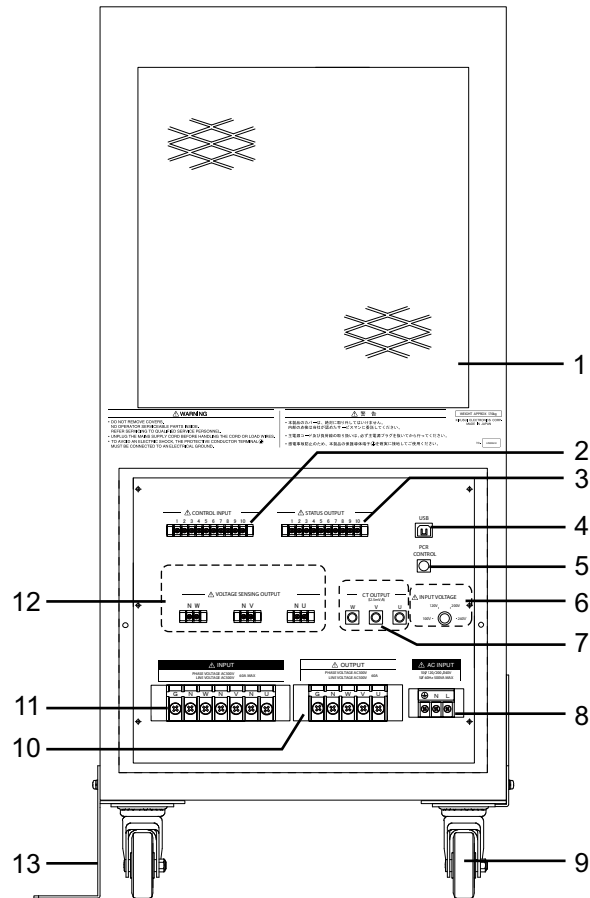

No.	Name	Function
1	Air outlet	Air outlet for internal cooling
2	CONTROL INPUT	Contact signal control input terminal
3	STATUS OUTPUT	Status output terminal
4	USB	Remote control USB port (factory option) The USB port is not available if the factory option has not been installed. A cover will appear where the USB port would be.
5	PCR CONTROL	AC power supply control terminal
6	INPUT VOLTAGE	Control power supply voltage selector
7	CT OUTPUT	CT (current transformer) output terminal
8	AC INPUT	Control power supply input terminal
9	Caster	Caster (without a lock)
10	OUTPUT	Output terminal block: G • N • W • V • U
11	INPUT	Input terminal block: G • N • W • N • V • N • U
12	VOLTAGE SENSING OUTPUT	Sensing terminal
13	Base hold angle	L-shaped bracket for fixing the product to the installation location

INPUT and OUTPUT terminals

The INPUT and OUTPUT terminals are impedance input and output terminals. There is an independent terminal for each phase: U, V, W, and N. The input and output terminals are used according to the test circuit system.

The size of the terminal block screws is M6. The nominal cross-sectional area of wires is 22 mm² minimum.

If the sensing function of the AC power supplies cannot be used, the length of the wires will be limited more than that when the sensing function can be used.

VOLTAGE SENSING OUTPUT terminal (for the PCR-LE and PCR-LE2)

The VOLTAGE SENSING OUTPUT terminal is connected to the sensing terminal of the PCR-LE or PCR-LE2. There is an independent terminal for each phase: U, V, W, and N. Each terminal is used according to the wiring system.

See p.51, p.54

When the sensing function is used, the output terminal of the PCR-LE or PCR-LE2 appears as if it is the resistor connection point of the product. As such, the impedance between the output terminal of the PCR-LE or PCR-LE2 and the resistor connection point of the product can be assumed to be zero. This reduces the effects of wiring impedance, and increases the degree of freedom in the wiring length when integrating the impedance into the test system.

Sensing can only be used with the PCR-LE and PCR-LE2 AC power supplies. It cannot be used with the PCR-LA, PCR-L, or AC power supplies made by other manufacturers. In such a case, to ensure the impedance characteristics, make sure that the wires used between the AC power supplies and the INPUT terminal of the LIN3060J meet the specified conditions.

If sensing cannot be used, do not connect anything to the VOLTAGE SENSING OUTPUT terminal.

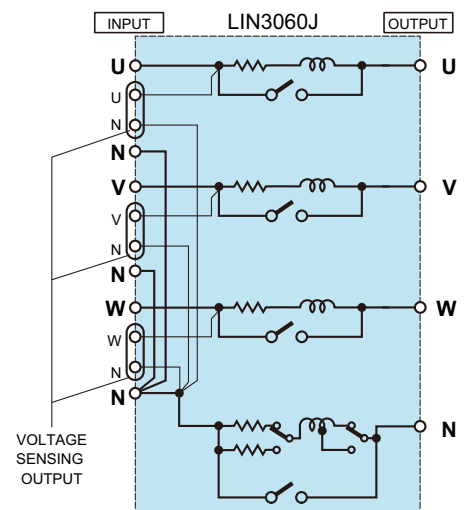

CT OUTPUT terminal (current monitoring)

The CT OUTPUT terminal transmits signals from the CTs provided for each phase. It is a BNC terminal for monitoring the current of each phase.

Output voltage per unit of current is approximately 12.5 mVrms/A (built-in 25 Ω terminator).

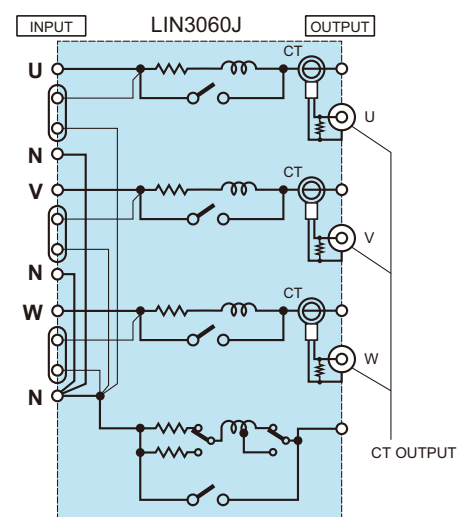

AC INPUT (control power supply input terminal)



WARNING Risk of electric shock.

- This product conforms to IEC Safety Class I (equipment that has a protective conductor terminal). Be sure to earth ground the product to prevent electric shock.
- Connect the protective conductor terminal to earth ground.



CAUTION

- If the voltage distortion of the AC power line is large, the product may malfunction. The product cannot be connected to a generator or the like.
- Use the AC line for the input power supply. Do not supply power from the output of the AC power supplies that are connected to this product.

INPUT VOLTAGE (supply voltage) selector

AC INPUT can receive a nominal power supply voltage of 100 Vac, 120 Vac, 200 Vac, or 240 Vac at a frequency of 50 Hz or 60 Hz.

Set the supply voltage selector knob appropriately according to the nominal supply voltage that is being used.

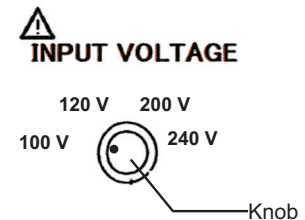

See
p.34



CAUTION

- Risk of product malfunction. Set the supply voltage selector to the nominal supply voltage that the control power supply input will be connected to. If you make a mistake in setting the voltage, immediately turn off the POWER switch.

PCR CONTROL terminal

The PCR CONTROL terminal is for controlling the AC power supplies. The AC power supplies that can be used are PCR-LE, PCR-LE2, PCR-LA, and PCR-L. When the overheat protection of this product is activated, this terminal transmits a signal and turns off the AC power supply output. Use the supplied exclusive cable for connecting this terminal. This function cannot be used if the AC power supplies made by other manufacturers.



CAUTION

- The PCR CONTROL terminal must be connected properly to the AC power supplies for the AC power supply output to be turned off when the overheat protection of this product is activated (ALARM indicator turns on).

■ When using AC power supplies made by other manufacturers

The PCR CONTROL terminal function cannot be used with AC power supplies made by other manufacturers. In this situation, the AC power supply output will not be turned off even when the product's overheat protection is activated (the ALARM indicator turns on).



CAUTION

- To secure safety, when the ALARM indicator on the front panel turns on, turn off the AC power supply output.

CONTROL INPUT and STATUS OUTPUT terminals

You can use the CONTROL INPUT terminal to control the product's impedance externally. You can use the STATUS OUTPUT terminal to monitor the product status. The size of the terminal block screws is M3. The nominal cross-sectional area of wires is 0.75 mm² (AWG18) minimum. The following figure shows the internal equivalent circuits of both terminals.

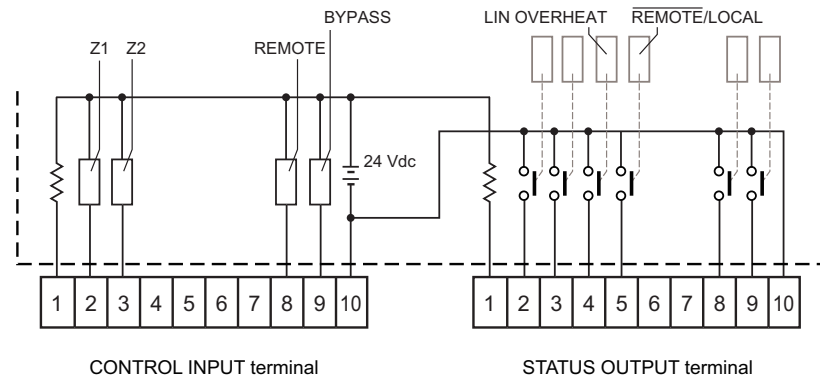

USB port

See p.41

You can use the USB port to remotely control the product. To do so, connect the product's USB port to a USB port on your PC.

3 Wiring the Test System

This chapter describes how to wire the product to the test system.



WARNING

- Risk of electric shock. For the devices that will be used in the test circuit, be sure to remove the power cable from the AC power line, turn off the switchboard that the power cable is connected to, and turn off the POWER switch.

Removing the Terminal Cover

Remove the terminal cover, and then connect the terminals. After connecting the terminals, be sure to attach the terminal cover back on using the left and right screws.

- 1 Check that the POWER switch is turned off.**
Check that the power indicator on the front panel is off.
- 2 Unfasten the screws from the terminal cover attached to the lower part of the rear panel of this product.**
Leave the cover open until all wiring is finished.

Connecting the Control Power Cable

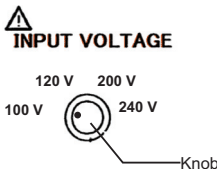

- 1 Set the INPUT VOLTAGE (supply voltage) selector.**
Set the supply voltage selector knob appropriately according to the nominal supply voltage that is being used.
The selectable voltages are 100 Vac, 120 Vac, 200 Vac, and 240 Vac.



CAUTION

- Set the INPUT VOLTAGE (supply voltage) selector to the nominal supply voltage that the control power supply input will be connected to.

- 2 Connect the supplied control power cable to the AC INPUT terminal on the rear panel.**
- 3 Connect the control power cable plug to a properly grounded outlet.**

Wiring the Test Circuit

The test circuits provided on the following pages are grouped by the number of AC power supplies (PCR-LEs or PCR-LE2s), and the different input power supply systems (single-phase two-wire, single-phase three-wire, three-phase three-wire, and three-phase four-wire) of the EUT are described. The input power supply systems of the EUT will be denoted as 1P2W for single-phase two-wire, 1P3W for single-phase three-wire, 3P3W for three-phase three-wire, and 3P4W for three-phase four-wire.

 See p.15, p.49, p.55

The wiring diagrams use schematic symbols to make the entire wiring easier to understand. For details on how to connect the actual terminals, see the description of each part, the appendixes, or the operation manual of the relevant product.

NOTE

- The G terminal in the wiring diagrams is not the protective conductor terminal. Connecting to the G terminal will not ground the device.

Nominal cross-sectional area of wires

Circuit	Nominal cross-sectional area	Be sure to observe the nominal cross-sectional area.
Primary current circuit	22 mm ²	This is especially important in the primary current circuit to ensure proper impedance characteristics.
Sensing	0.75 mm ²	
KHA3000 voltage measurement	0.75 mm ²	

Parts to have ready

Please prepare your own wires and crimping terminals for connecting between the devices of the test circuit.

Select wires with sufficient withstanding voltage for the test voltage that will be used. Using wires with a rated voltage of 600 V or higher will ensure safety up to the maximum output voltage of the AC power supplies.

We recommend that you use terminals, wires, and the like with appropriate safety (e.g. UL) certifications.

If the sensing function cannot be used

Sensing can only be used with the PCR-LE and PCR-LE2 AC power supplies. It cannot be used with the PCR-LA, PCR-L, or AC power supplies made by other manufacturers. In such a case, to ensure the impedance characteristics, make sure that the wires used between the AC power supplies and the input terminal of the LIN3060J meet the conditions (nominal cross-sectional area and maximum length) specified in the wiring diagrams in the following pages.

CAUTION

- If the sensing cables become disconnected or the polarities are incorrect, an overvoltage will be generated in the output of the AC power supplies. This will cause the protection function of the AC power supplies to be activated, turning off the output.

Single-phase One PCR-LE

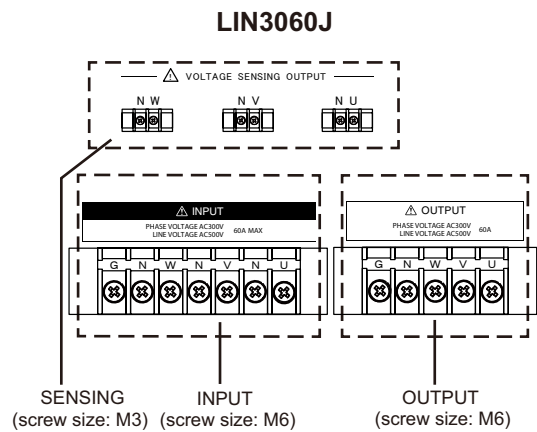
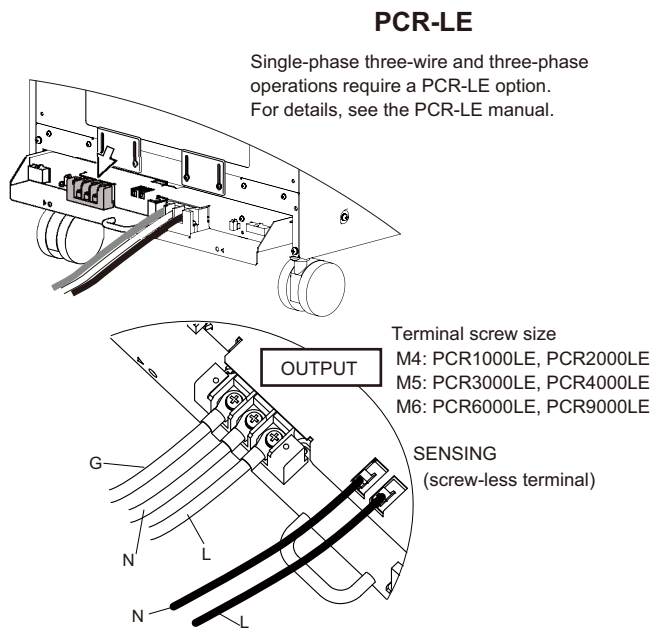
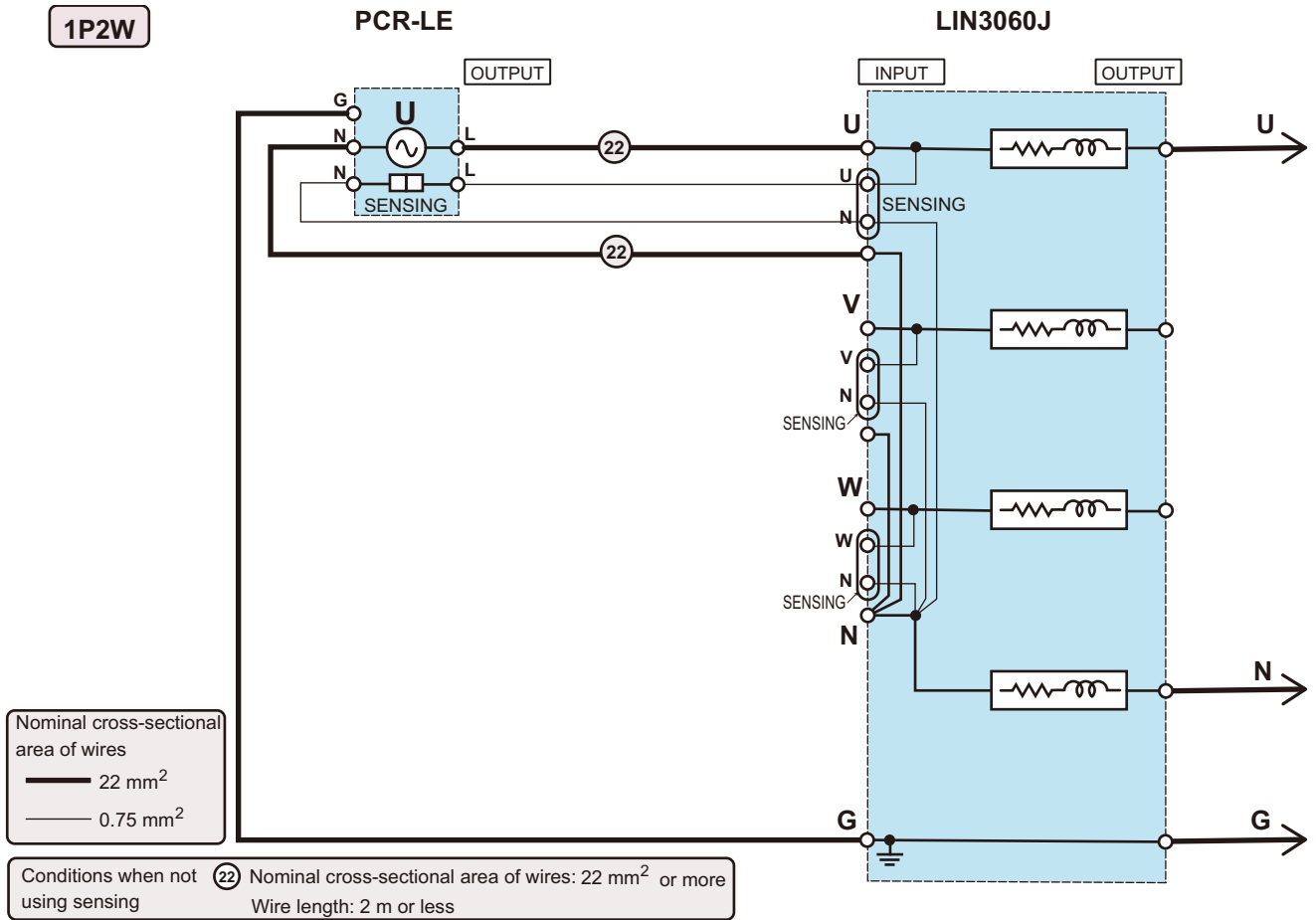

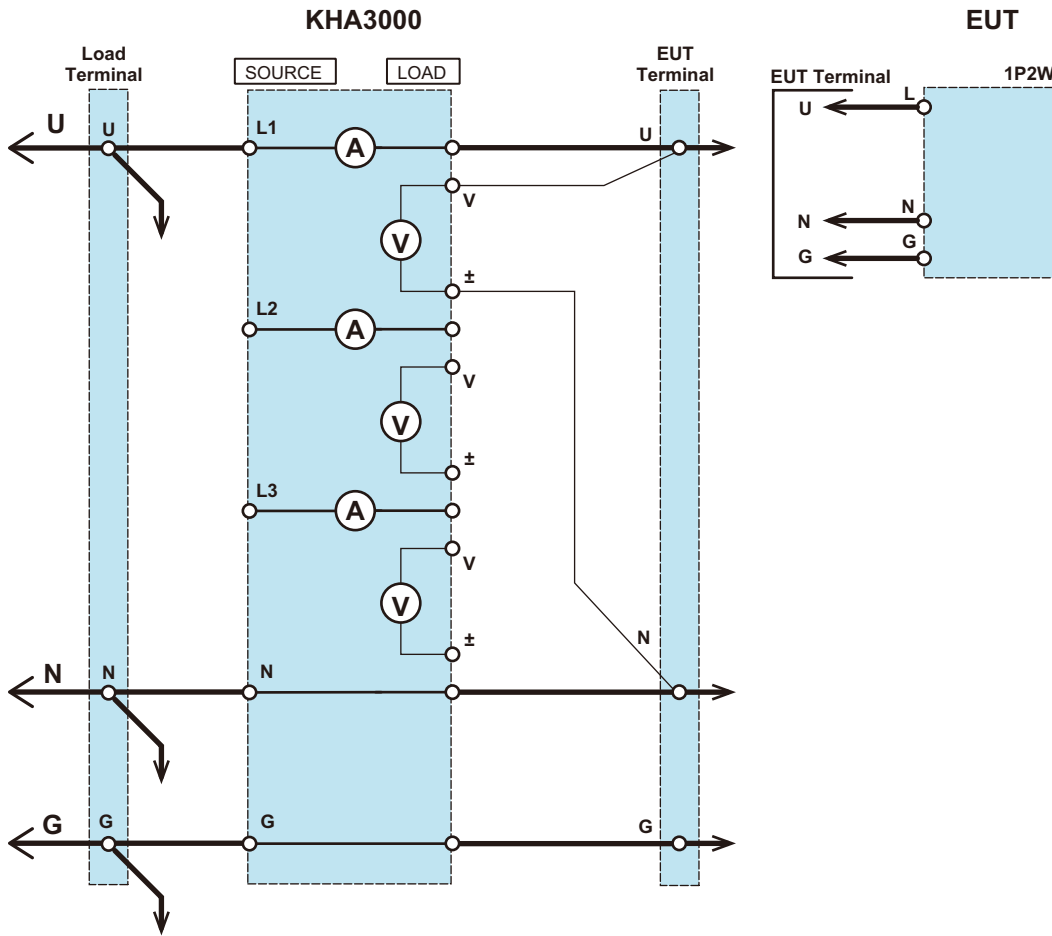

Connect the load to the load terminal.

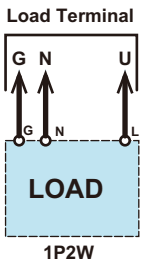

KHA3000

Voltage input terminals are L1, L2, and L3 inputs only.

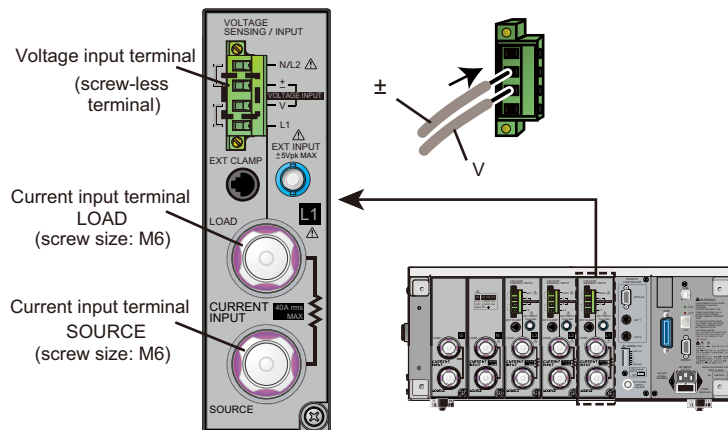

Single-phase, Single-phase Three-wire Two PCR-LEs

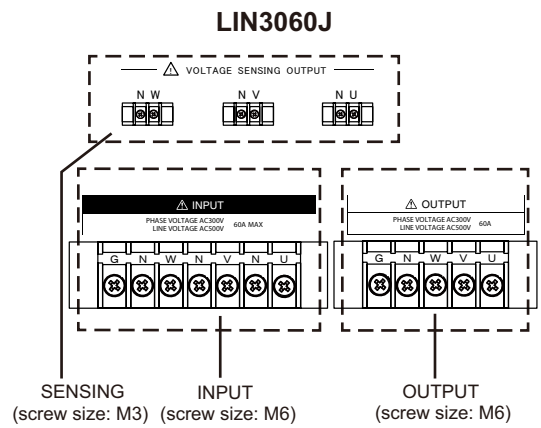
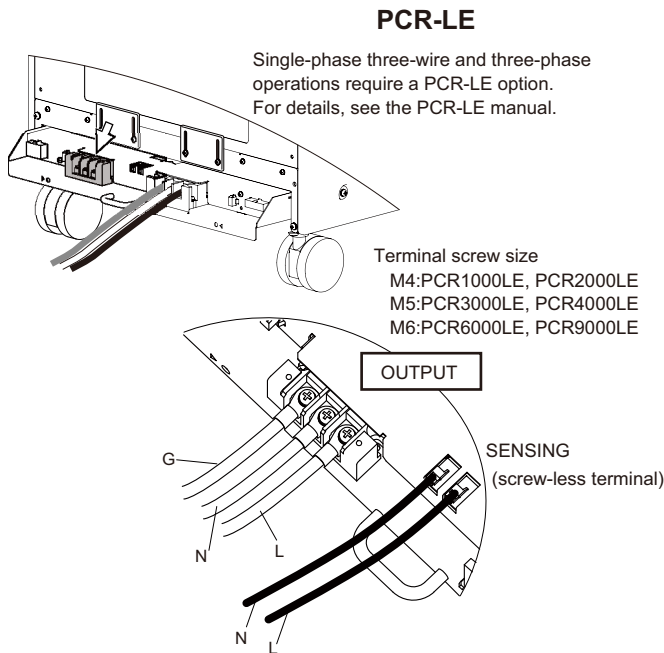
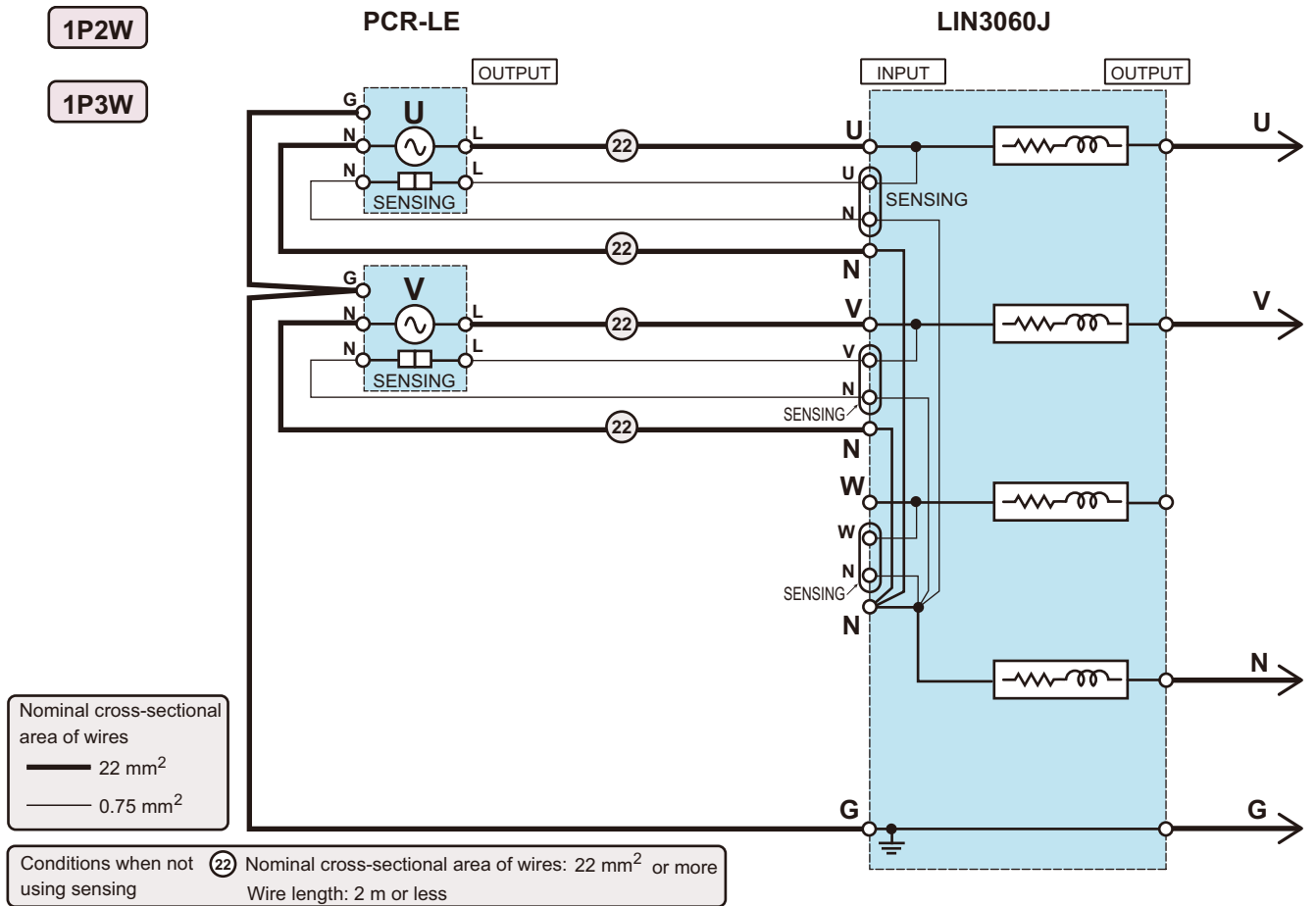

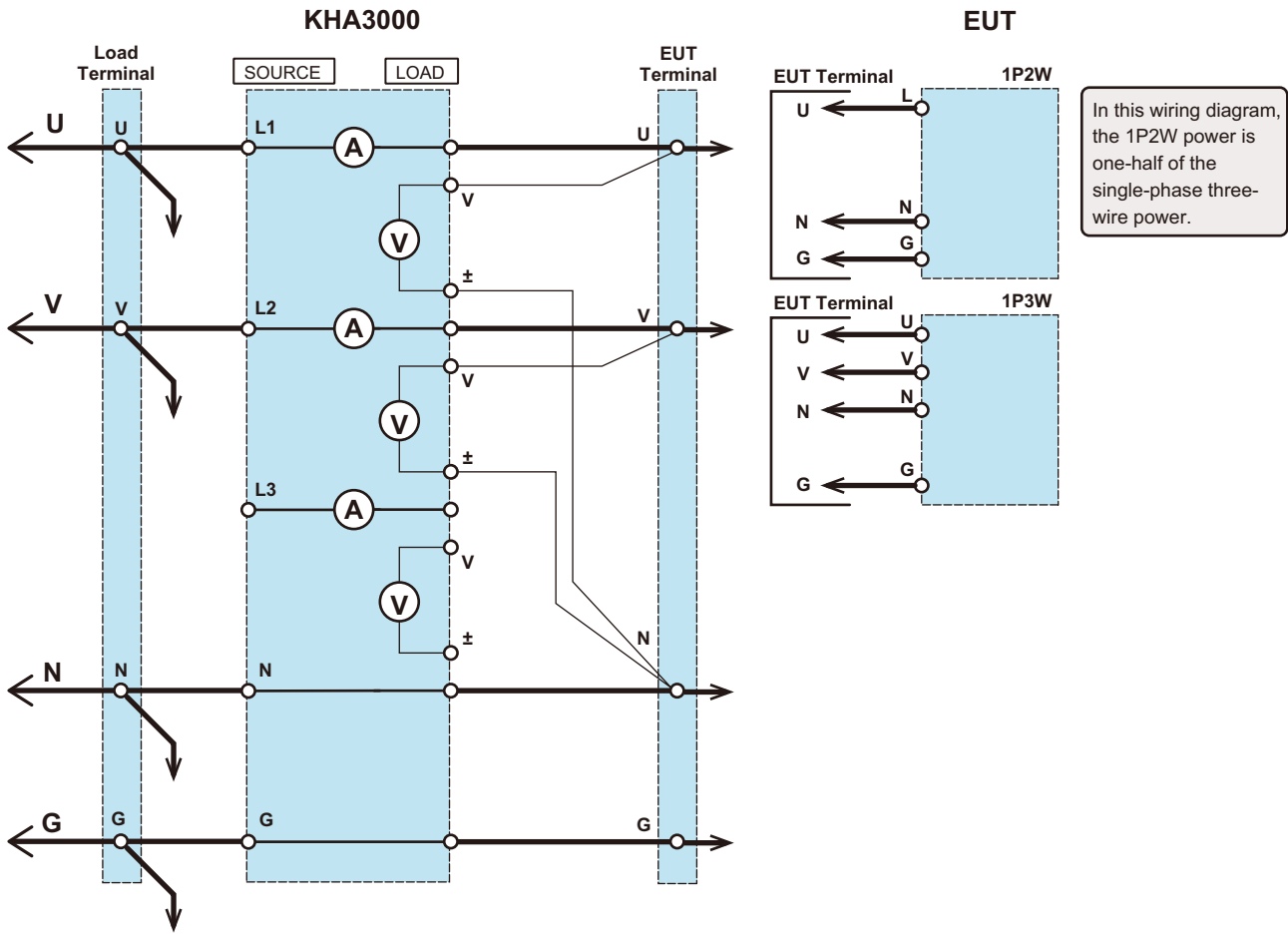

Connect the load to the load terminal.

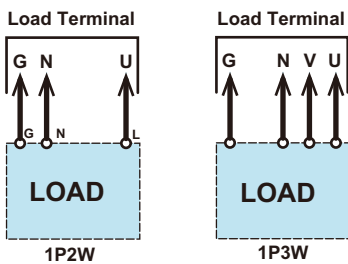

KHA3000

Voltage input terminals are L1, L2, and L3 inputs only.

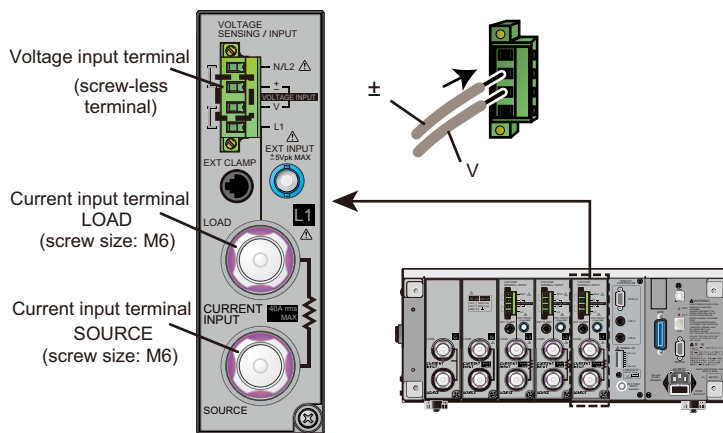

Single-phase, Three-phase Three PCR-LEs

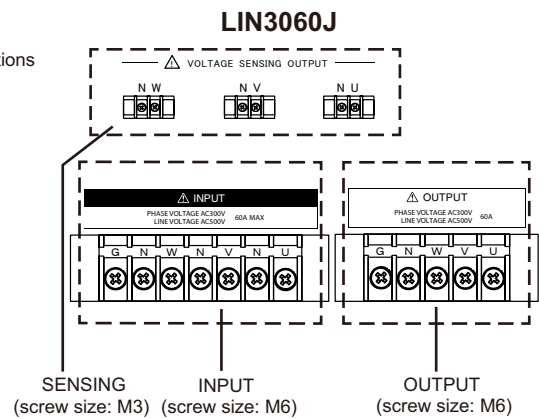
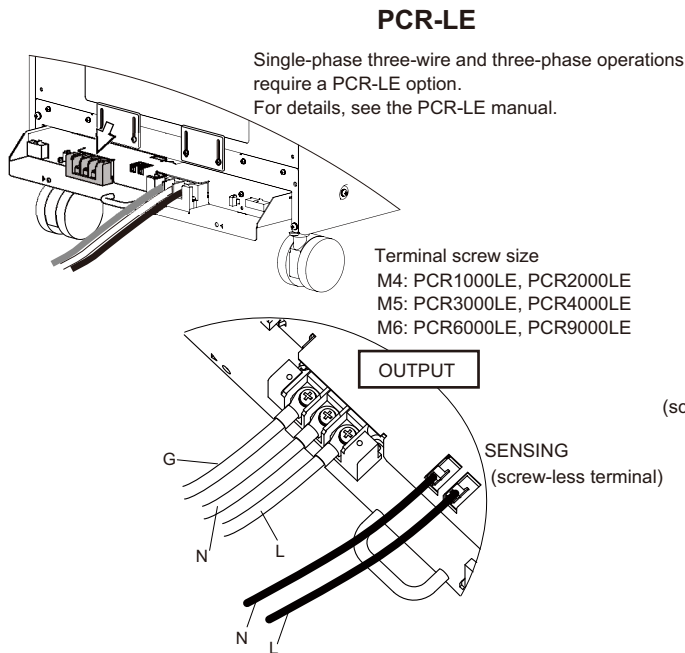
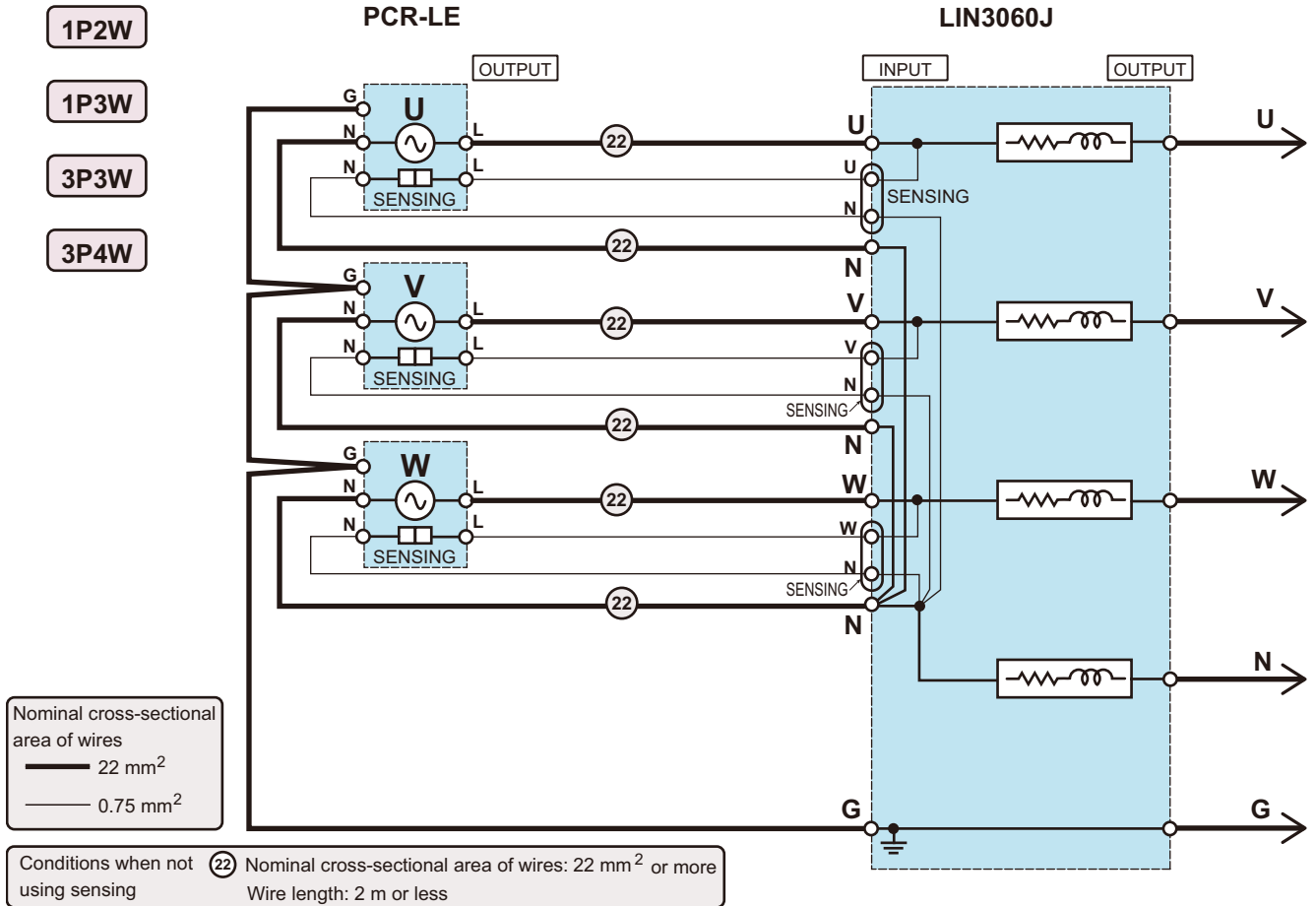

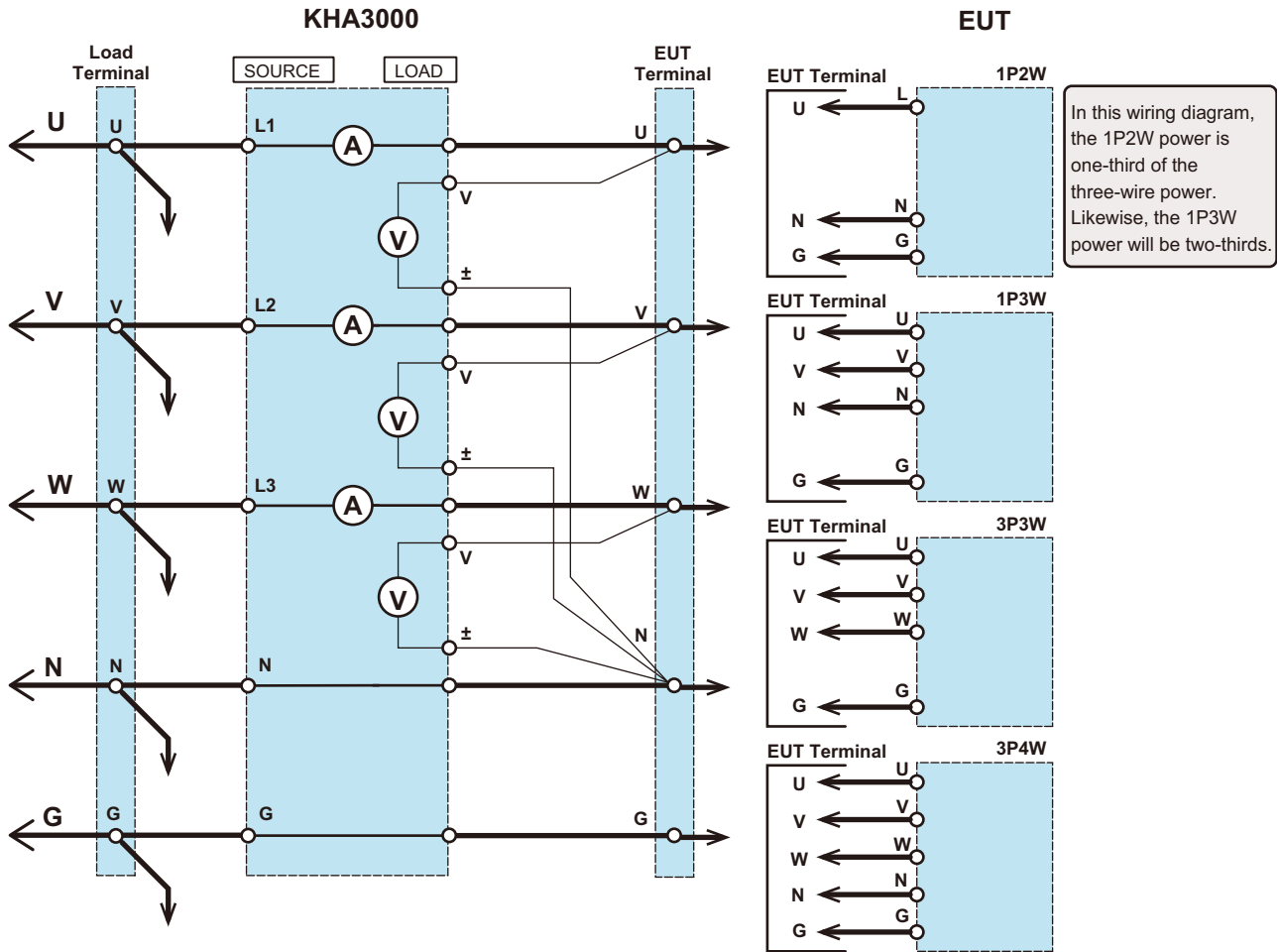

Connect the load to the load terminal.

KHA3000

Voltage input terminals are L1, L2, and L3 inputs only.

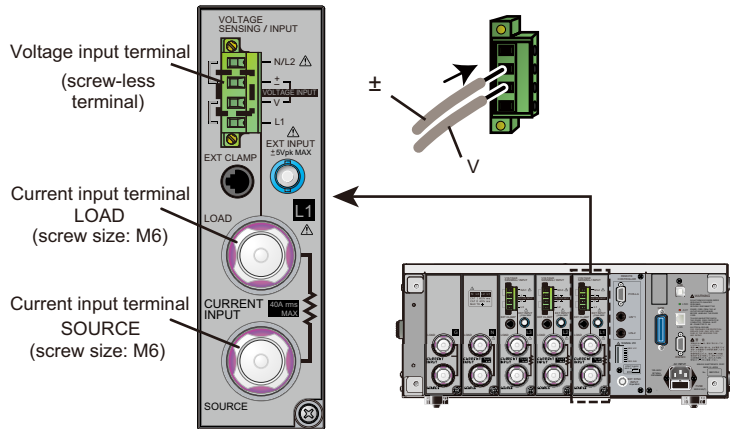
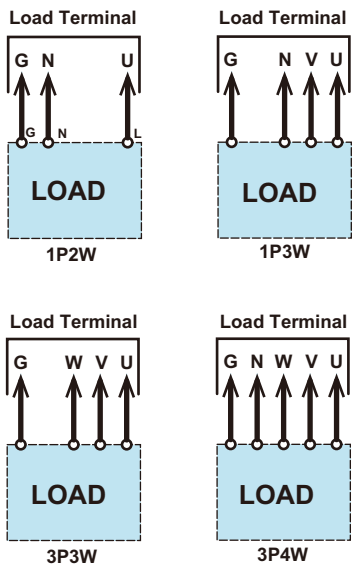

Single-phase One PCR-LE2

1P2W

PCR-LE2

LIN3060J

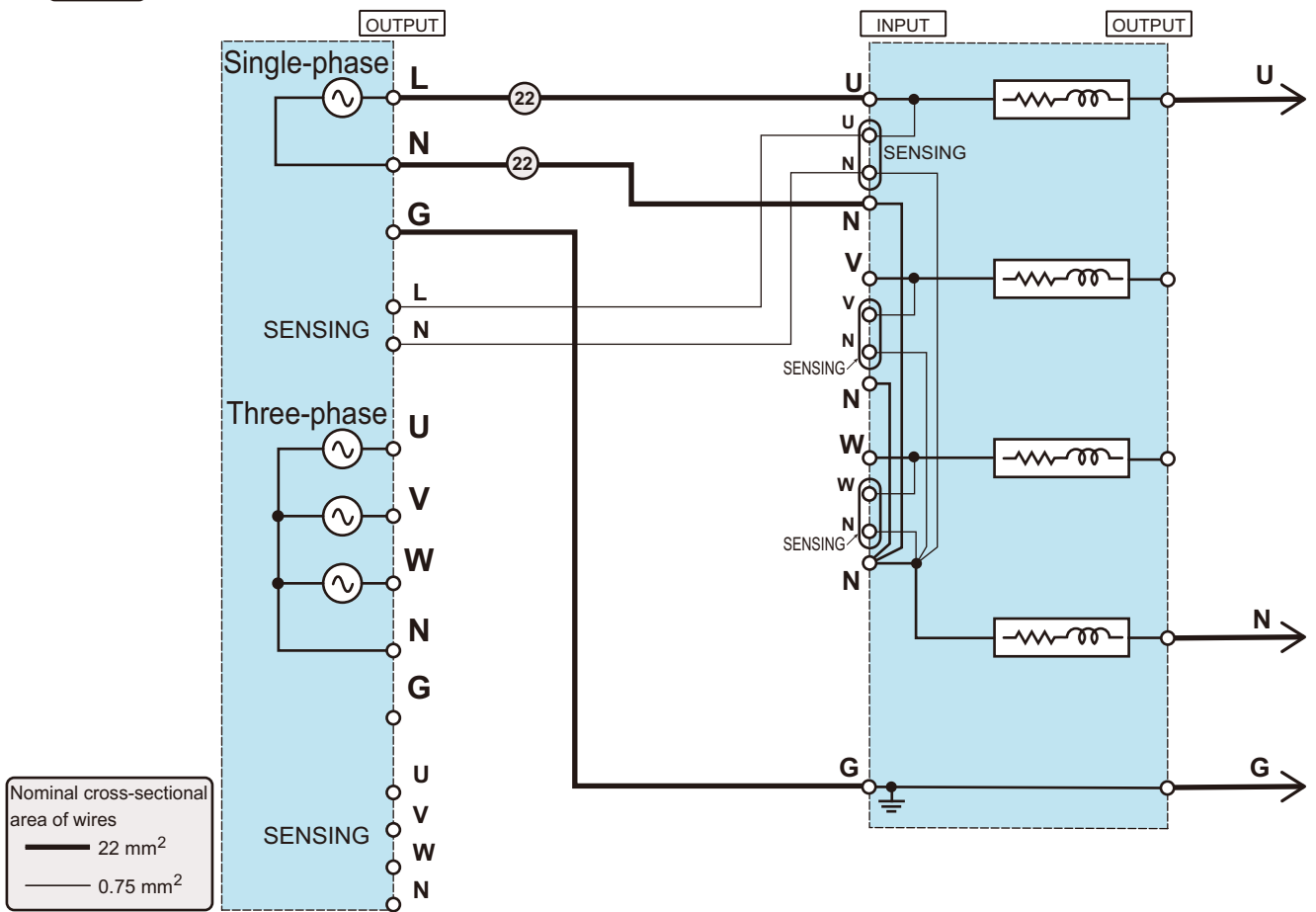

Nominal cross-sectional area of wires
 — 22 mm²
 — 0.75 mm²

Conditions when not using sensing: ② Nominal cross-sectional area of wires: 22 mm² or more
 Wire length: 2 m or less

LIN3060J

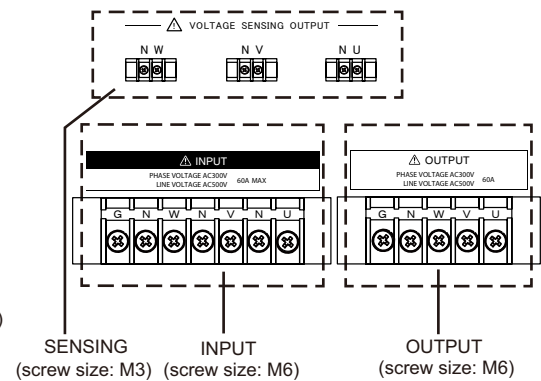
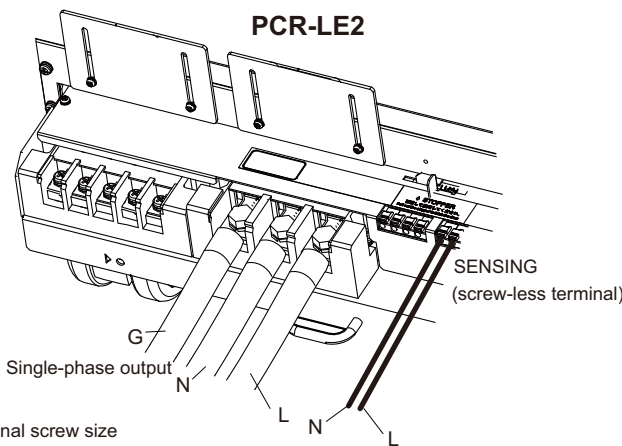

Terminal screw size
 M8: PCR600LE2, PCR900LE2
 M8: PCR2700LE2

The output terminal shape on the PCR2700LE2 is different from what is shown above. For details see the PCR-LE2 setup guide or user's manual.

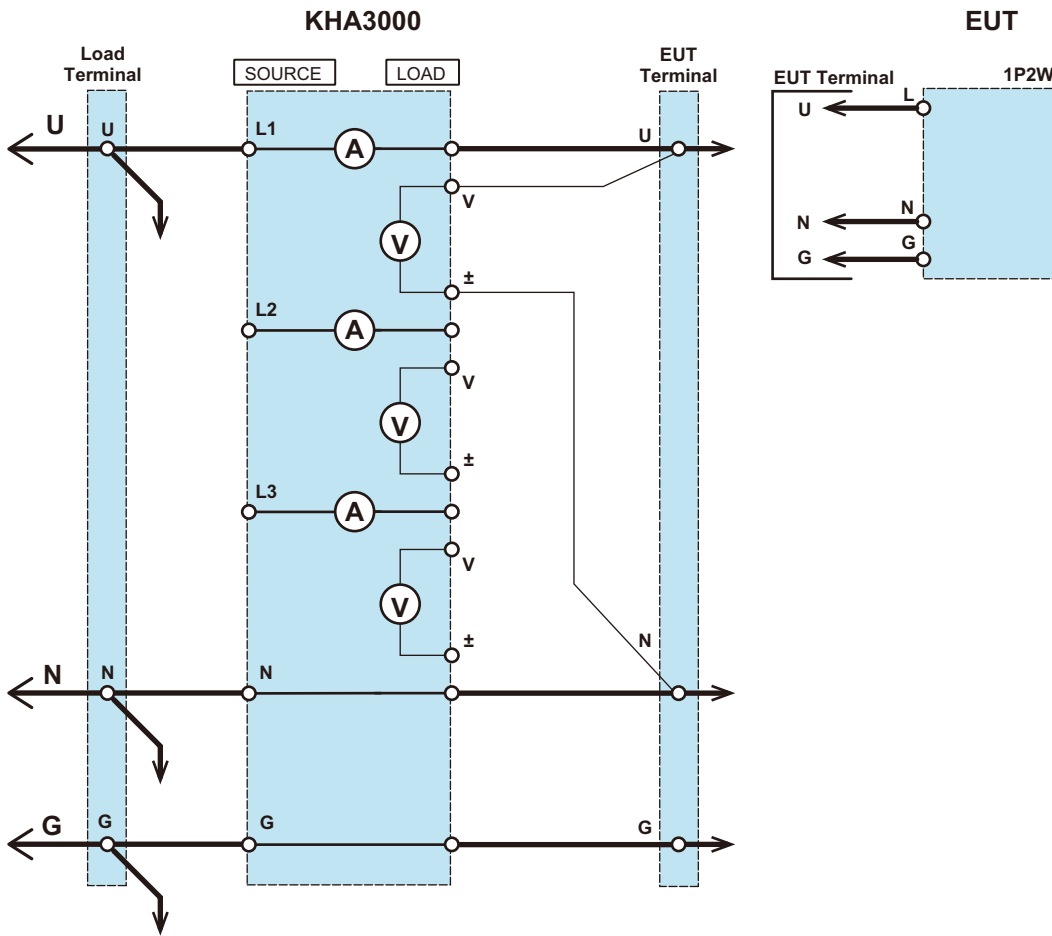

Connect the load to the load terminal.

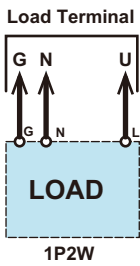

KHA3000

Voltage input terminals are L1, L2, and L3 inputs only.

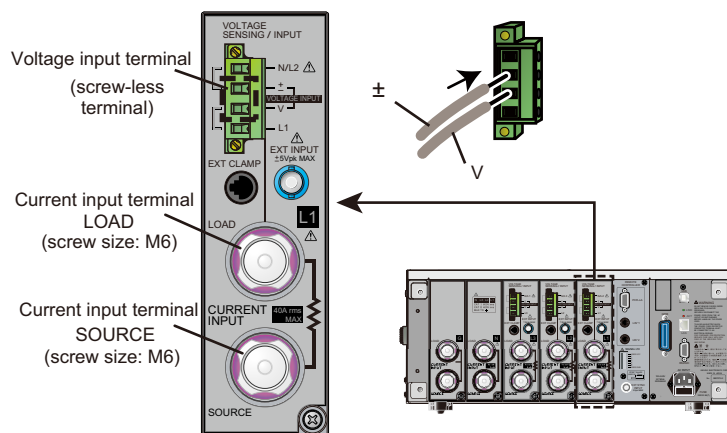

Single-phase, Three-phase One PCR-LE2

1P2W

1P3W

3P3W

3P4W

PCR-LE2

LIN3060J

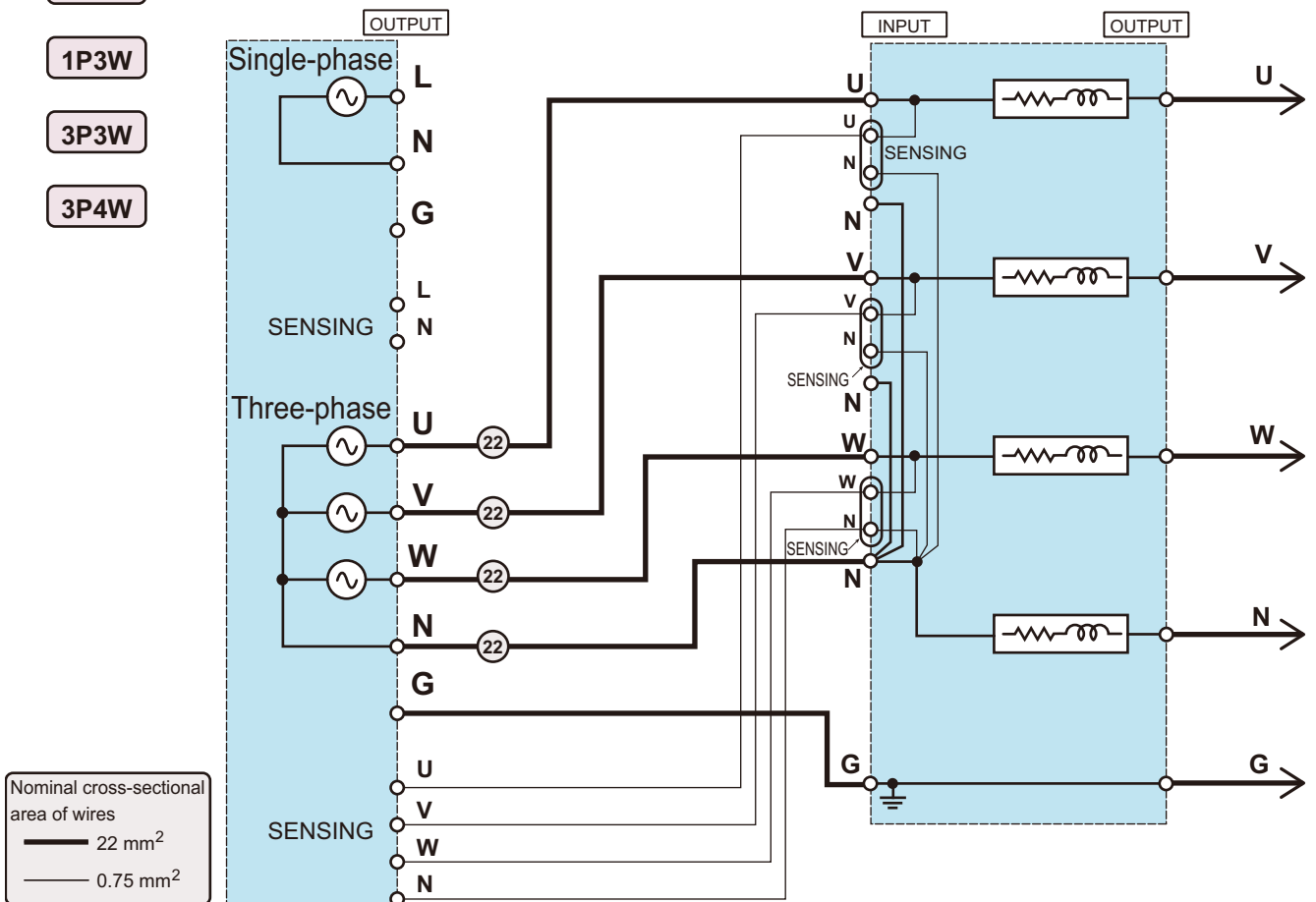

Nominal cross-sectional area of wires
 — 22 mm²
 — 0.75 mm²

Conditions when not using sensing (22) Nominal cross-sectional area of wires: 22 mm² or more
 Wire length: 2 m or less

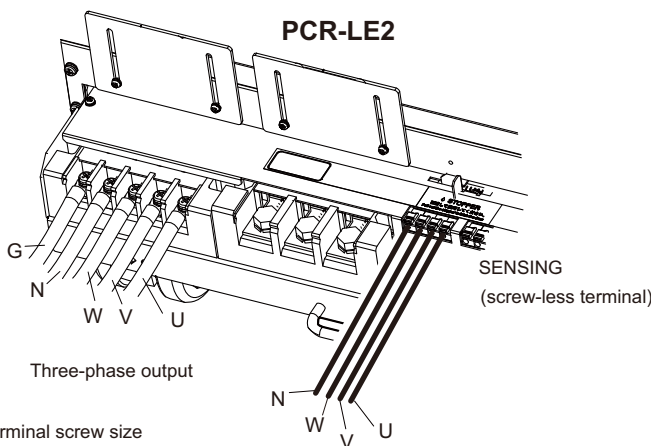

Terminal screw size
 M5: PCR6000LE2, PCR9000LE2
 M8: PCR27000LE2

The output terminal shape on the PCR27000LE2 is different from what is shown above. For details see the PCR-LE2 setup guide or user's manual.

LIN3060J

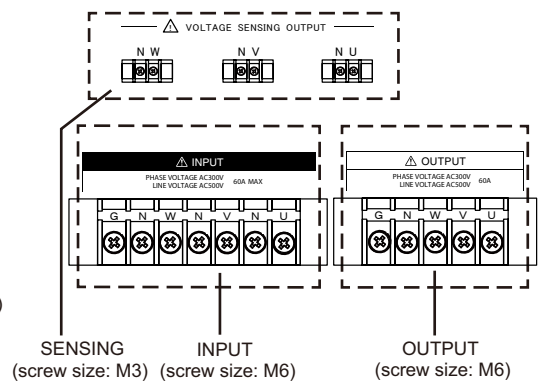

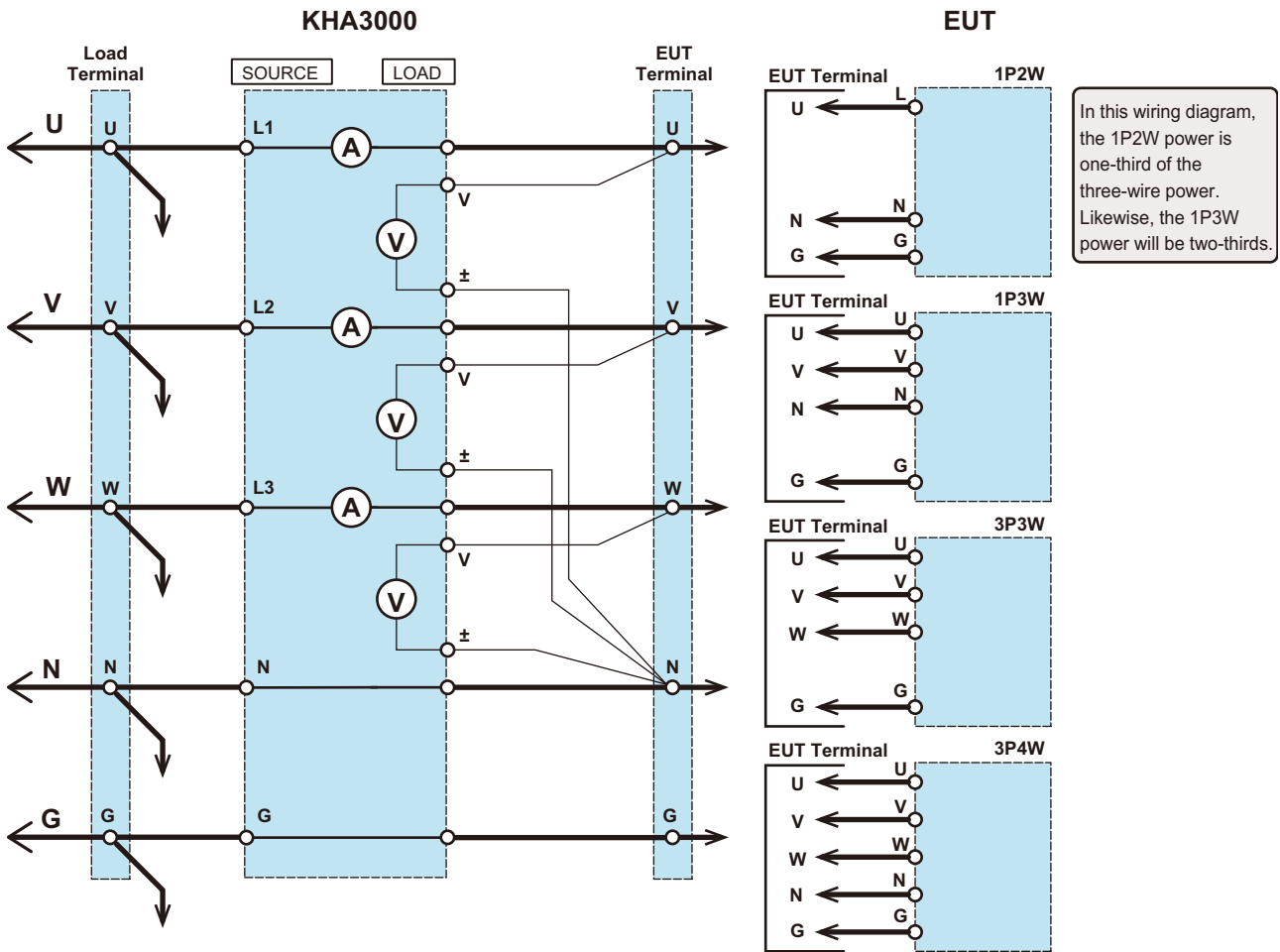

Connect the load to the load terminal.

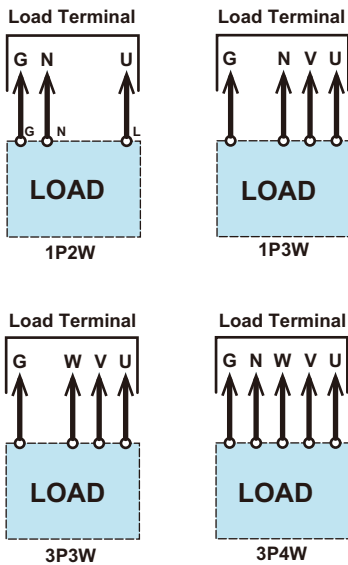

KHA3000

Voltage input terminals are L1, L2, and L3 inputs only.

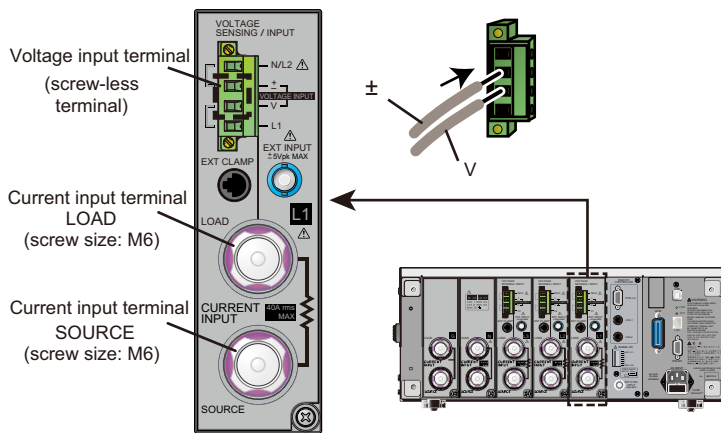

Connecting the Control Terminals

Connecting the PCR CONTROL terminal

The PCR CONTROL terminal is for controlling the AC power supplies. When the overheat protection of this product is activated, this terminal transmits a signal and turns off the AC power supply output. Use the supplied exclusive cable for connecting this terminal.

The following figures show connection examples of the PCR-LE and PCR-LE2. The connection is similar for the PCR-LA and PCR-L, but the slot number of the AC power supply is different. This function cannot be used if the AC power supplies made by other manufacturers.

If you want to use this product with the DSI series dip simulator in the test system, connect the DSI series to the AC power supplies first, and connect this product last. For details, see the operation manual for the DSI series.

Installing the supplied control boards into the AC power supplies

■ Control board slot

AC power supply	Slot
PCR-LE series	Slot 3
PCR-LE2 series	Slot 3
PCR-LA series	Slot 3 or 4
PCR-L series	Slot 4 or 5



CAUTION Do not touch the circuit board area of the control board. Static electricity may damage the circuit.

- 1** Check that the **POWER** switches of the AC power supplies are turned off (○).
In addition, shut down the power supply from the switchboard.
- 2** Touch a grounded metal object (for example, the metal parts of the rear panel) to discharge any static electricity from your body.
- 3** Remove the screws that are holding the **SLOT 3** cover in place on the rear panel, and remove the cover from the panel.
Keep the cover in a safe place. The screws that you removed will be used in step 6.

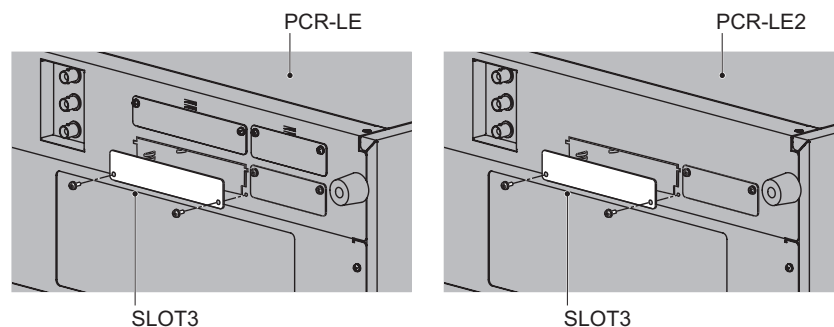

- 4** Flip the control board so that the side with the components is facing down, and hold the panel area of the board.
- 5** Insert the board all the way into the slot so that the connector is firmly inserted into the slot.
- 6** Use the screws that you removed earlier to fix the control board in place in the panel.

Connecting the supplied control cable

- 1** Check that the POWER switches of the LIN3060J and AC power supplies are turned off (○).
- 2** Connect the control cable supplied with the LIN3060J as shown in the following figure.

Connect one end of the cable to the connector of the control board that was installed in the AC power supply.
Connect the other end to the PCR CONTROL connector of the LIN3060J.

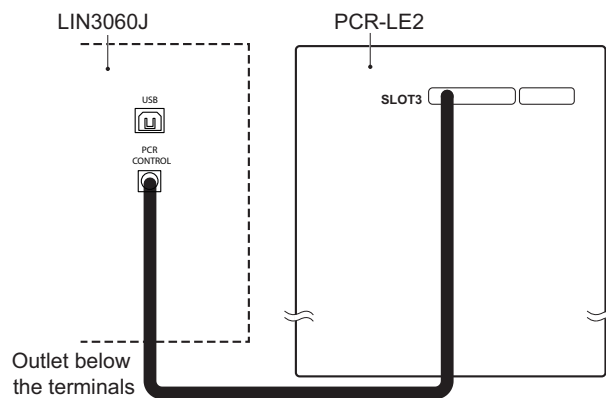
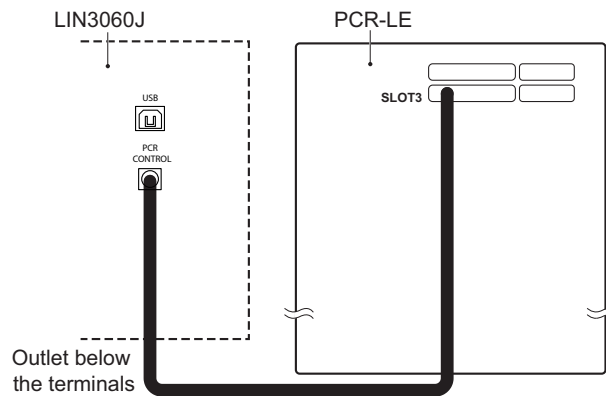

- 3** Attach the terminal cover on the rear panel of the LIN3060J.

4 Operation

This chapter describes how to turn on the product, how to select the impedance, how to configure the AC power supplies, how to configure the KHA3000, and how to handle alarms.

Powering On

Turning on the POWER switch

- 1 **Turn on the POWER switch of this product.**
The power indicator turns on, and the cooling fan starts rotating.

See
p.18

CAUTION

- Risk of product malfunction. Set the supply voltage selector to the nominal supply voltage that the control power supply input will be connected to. If you make a mistake in setting the voltage, immediately turn off the POWER switch.

If the INPUT VOLTAGE (supply voltage) selector is set incorrectly

- **If the INPUT VOLTAGE (supply voltage) selector is set to a 100 V system (100 V or 120 V) and the product is mistakenly connected to a 200 V nominal power supply**
Overvoltage protection will be activated. The internal relay will shut off the circuit, and the operation will be aborted. The POWER switch will remain turned on. The overvoltage protection is activated when the input voltage exceeds approximately 135 Vac.

CAUTION

- Even though the overvoltage protection will be activated, to secure safety, be sure to turn off the POWER switch. Set the supply voltage selector correctly, and then turn the POWER switch back on.

- **If the INPUT VOLTAGE (supply voltage) selector is set to a 200 V system (200 V or 240 V) and the product is mistakenly connected to a 100 V nominal power supply**
The undervoltage protection will not be activated. Because the internal circuit will not be shut off, the operation will not be aborted. The POWER switch will remain turned on.
The cooling fan will rotate slower than usual or may stop.

CAUTION

- To secure safety, be sure to turn off the POWER switch and turn off the AC power supply output. Set the supply voltage selector correctly, and then turn the POWER switch back on.

NOTE

- If you do not turn off the POWER switch, insufficient cooling will eventually cause the over-heat protection to be activated, and the ALARM indicator will turn on.

Selecting the impedance

There are impedance (IMPEDANCE SELECT) switches for Z1, Z2, and BYPASS. Each switch is an independent bi-stable push switch. The switch is on when the button is pressed in (illumination area is turned on) and off when the button is not (illumination area is turned off). The button toggles between on and off each time you press it.

The switches are not interlocked. As such, if multiple switches are on at the same time, all the selected circuits will be connected in parallel.

If all switches are off, no impedance is selected, and the N-phase circuit is open.

- 1 Turn off the AC power supply output.**
- 2 Turn off the REMOTE switch on the front panel.**
Set the switch so that the button is not pressed in. The illumination area of the REMOTE switch will turn off, and panel control will be enabled.
- 3 Turn off all impedance (IMPEDANCE SELECT) switches on the front panel.**
Press one of the Z1, Z2, Z3, and BYPASS switches.
The illumination area of the selected switch will turn on.
- 4 To select another impedance, press the impedance switch that you want to turn on and then the switch you want to turn off.**

■ Operation example

The following procedure is for switching from Z1 to Z2.

- 1 Press Z2.**
The Z1 and Z2 illumination areas turn on. Both impedance switches are on in this condition.
- 2 Press Z1.**

Configuring the AC Power Supplies (PCR-LE and PCR-LE2)

The configuration of the AC power supplies provided below is necessary when using this product. For details, see the operation manual for the PCR-LE or PCR-LE2 series.

Setting hardware sensing

To cancel out the effects of wiring impedance (between the AC power supply output and LIN3060J), be sure to enable hardware sensing (SENS-H). Otherwise, there will be errors in the impedance value prohibiting accurate measurements.

Setting the response

To perform harmonic or flicker evaluation of an EUT with a large capacitor in its input power supply circuit, set the AC power supply response to SLOW (highly stable). When this product's impedance is set to BYPASS for such an EUT, if the AC power supply response is set to MEDIUM (normal speed), the AC power supply response may become unstable (may oscillate).

Output current limit of the AC power supplies

The maximum rated current of this product is 60 Arms (continuous).



- To ensure safety of this product and EUT, set the output current of the AC power supplies to 60 A or less. Set a current limit on the AC power supply output to prohibit the output from exceeding 60 A.

We recommend that you use the current limit feature on the AC power supplies to prevent the test circuit from overheating due to overcurrent and to protect the EUT. The overheat protection of this product shuts off the current if the internal resistive element heats up due to overcurrent.

Power level supplied from the test circuit to the EUT

With the test circuit common to single-phase and three-phase, the 1P2W power will be one-third that of three-phase power. Likewise, the 1P3W power will be two-thirds.

Example: If the three-phase power is 6000 W, the 1P2W power will be 2000 W, and the 1P3W power will be 4000 W.

Configuring the KHA3000

For three-phase three-wire circuits

See p.56

When used in a three-phase test circuit, the KHA3000 voltmeter is designed to be used in a three-phase four-wire system. To use it in a three-phase three-wire circuit, you can use the delta transformation feature of the KHA3000, rather than changing the actual wiring. The delta transformation feature is used to convert phase voltage measurements to line voltages. For the setup procedure, see “Delta transformation (star-delta transformation)” in the appendix.

Handling Overheat Alarms

When the overheat protection function of this product is activated, the internal phase circuits are opened, shutting off the current. If the PCR CONTROL terminal function is used, the AC power supply output can also be turned off when the overheat protection function is activated. The detailed operation is described below.

Overcurrent (when the PCR CONTROL terminal function can be used)

The overheat protection function is activated, and the AC power supply output is turned off. The LIN OVERHEAT status signal is transmitted from the STATUS OUTPUT terminal.

Step	Handling
1	Leave the product's POWER switch turned on. This will keep the fan running for cooling.
2	After cooling the product adequately, turn on the POWER switch, and investigate the cause of the overcurrent.

Overcurrent (when the PCR CONTROL terminal function cannot be used)

See p.32

- When the PCR CONTROL terminal is not connected to the AC power supplies or the connection is incomplete
- When using AC power supplies made by other manufacturers

In this situation, the AC power supply output will not be turned off even when the product's overheat protection is activated. However, the LIN OVERHEAT status signal will be transmitted from the STATUS OUTPUT terminal.

Step	Handling
1	To secure safety, when the ALARM indicator on the front panel turns on, turn off the AC power supply output.
2	Leave the product's POWER switch turned on. This will keep the fan running for cooling.
3	After cooling the product adequately, turn on the POWER switch, and investigate the cause of the overcurrent.

5 Remote Control

This chapter describes remote control using the CONTROL INPUT terminal or USB. The USB remote control function is a factory option. In this manual, contact signal control refers to the notion of remote control using the CONTROL INPUT terminal.

Switching to Remote Control Mode

Switching between panel control and remote control

You can select the impedance from the front panel or through remote control.

NOTE

- To switch between panel control and remote control, use the REMOTE switch on the front panel. You cannot set this from a PC.

■ Switching to remote control mode

- 1 Press REMOTE on the front panel to turn it on.**
The switch is on when the button is pressed in. Remote control is enabled.
- 2 Apply a remote signal to the CONTROL INPUT terminal on the rear panel.**
When the REMOTE switch is on and the remote signal is being received, the product switches to remote control mode, and the illumination area of the REMOTE switch turns on.

■ Switching to panel control mode

- 3 Press REMOTE on the front panel to turn it off.**
The switch is off when the button is released (illumination area is turned off). The product switches to panel control mode, regardless of whether a remote signal is being received.

Controlling the Product Using Contact Signals

You can use an external sequencer contact signal output or a digital I/O controller through the CONTROL INPUT terminal to select the product's impedance. You can use the STATUS OUTPUT terminal to check the product status.

CONTROL INPUT terminal

No.	Signal name	Relay operation current	Function
1	24 Vdc	—	Internal power supply output (with a 470 Ω protective resistor)
2	Z1	100 mA or less	Selects impedance Z1
3	Z2		Selects impedance Z2
4	NC	—	—
5	NC	—	—
6	NC	—	—
7	NC	—	—
8	REMOTE	100 mA or less	Enables remote control
9	BYPASS		Bypasses the impedance
10	Circuit common	—	—

The current absorption by an external circuit activates the internal relay. Of Z1, Z2, and BYPASS, only one can be selected at any given time. If all switches are off, no impedance is selected, and the N-phase circuit is open. The internal relay operation current is approximately 100 mAdc (24 Vdc open voltage or less).

Example: Selecting impedance Z1

Set the REMOTE terminal to low level (connect to the circuit common). Next, set the Z1 terminal to low level (connect to the circuit common). This will select impedance Z1.

STATUS OUTPUT terminal

No.	Signal name	Contact rating	Function
1	24 Vdc	—	Internal power supply output (with a 470 Ω protective resistor)
2	RESERVE	5 Adc, 35 Vdc	Reserved bit: Fixed to low (short circuit)
3	RESERVE		Reserved bit: Fixed to open
4	LIN OVERHEAT	—	Overheat alarm
5	REMOTE/LOCAL	—	Remote mode
6	NC	—	—
7	NC	—	—
8	RESERVE	5 Adc, 35 Vdc	Reserved bit: Fixed to low (short circuit)
9	RESERVE		Reserved bit: Fixed to low (short circuit)
10	Circuit common	—	—

Contact output. The contact is active when it is shorted. When shorted, the contact is connected to the internal circuit common (contact rating of 5 Adc, 35 Vdc). When the contact is opened, the terminal potential is also opened.

● **LIN OVERHEAT (overheat alarm)**

This status signal is transmitted when the product's internal overheat protection function is activated. It is used to control external devices.

NOTE

- If you are using AC power supplies made by other manufacturers, use the LIN OVERHEAT status output to control the AC power supply output.
- If you are using Kikusui AC power supplies (PCR-LE, PCR-LE2, PCR-LA, or PCR-L) and the PCR CONTROL terminal is connected properly to the AC power supplies, the AC power supply output will be turned off when the overheat protection of this product is activated.

Example of contact signal control

The figure below shows a connection example for contact signal control. Isolate the contact signal control circuit from the internal circuit of this product with a photocoupler. The coil current of this product's impedance selection relay is 100 mA or less.

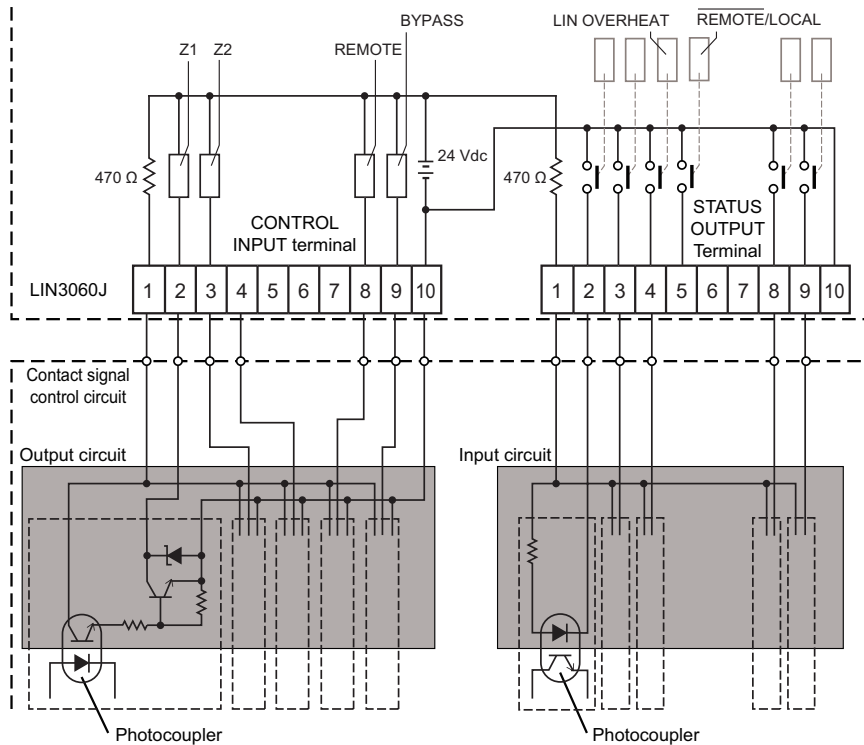

Example of a contact signal control device (reference)

To perform contact signal control, we recommend that you use the DIO-0808LY-USB Isolated Digital I/O Terminal for USB2.0 made by CONTEC. The DIO connectors CN1 and CN2 are used for this purpose.

Connect the product's CONTROL INPUT terminal to CN1 and the STATUS OUTPUT terminal to CN2. Connect the interface connector to a PC's USB port.

For details on the DIO connectors, see the Isolated Digital I/O Terminal for USB2.0 DIO-0808LY-USB User's Guide.

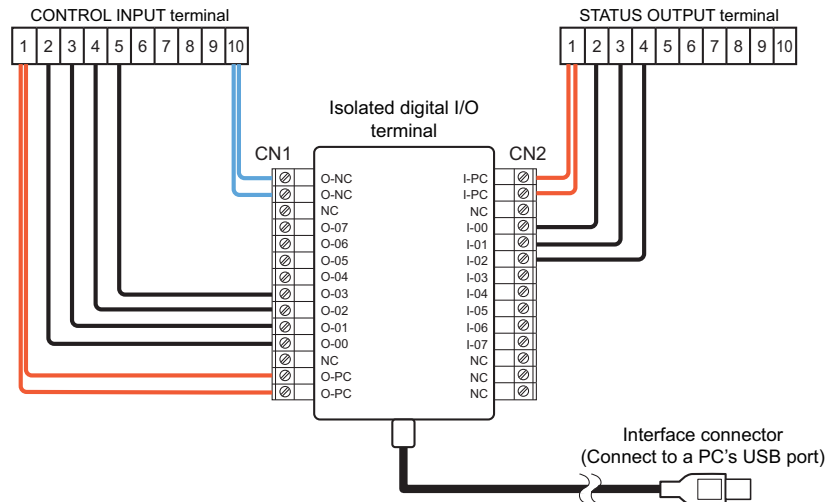

Connectors CN1 and CN2 are screw terminal blocks. Nominal cross-sectional area of wires is 0.08 mm² (AWG28) to 0.75 mm² (AWG18). The length of stripped wires is 9 mm to 10 mm.

Controlling the Product Using USB

A DIO is built into this product. You can remotely control this product through the USB port. For details on the operation, see the CONTEC API-USBP (WDM) help file. The USB remote control function is a factory option.

* DIO: DIO-0808LY-USB Isolated Digital I/O Terminal for USB2.0 (hereafter abbreviated as DIO) made by CONTEC.

USB port

You can use the USB port to remotely control the product. To do so, connect the USB port to a USB port on your PC.

The figure below shows how the USB port is connected internally. For details how to use the DIO, see the CONTEC API-USBP (WDM) help file.

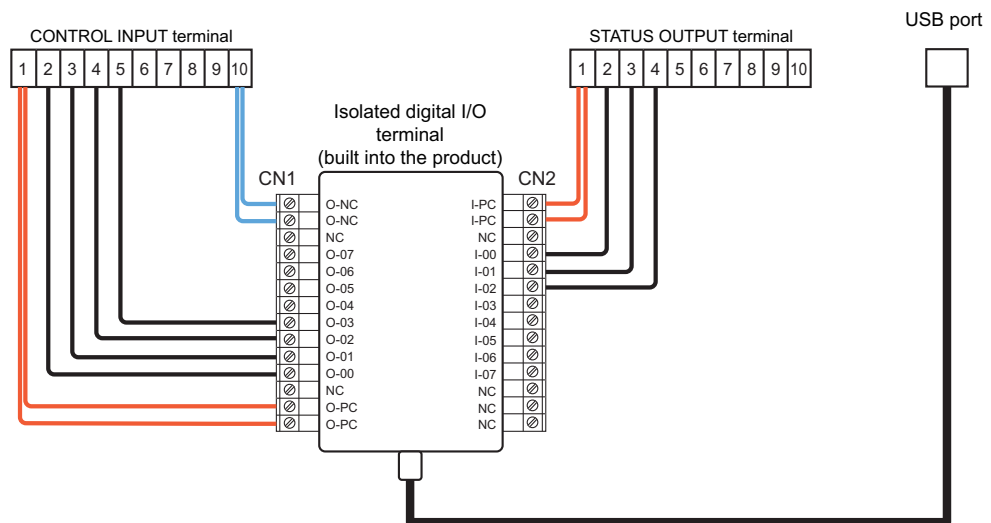

See p.40

■ Using the USB port and CONTROL INPUT terminal simultaneously

In remote control through the USB port, the control signal from the CN1 terminal (see the figure on the previous page) is connected to the product's CONTROL INPUT terminal. The output from the CN1 terminal is an open-collector circuit.

If you connect an open-collector circuit isolated by a photocoupler to the CONTROL INPUT terminal, you will be able to use the USB port and the CONTROL INPUT terminal simultaneously.

The coil current of this product's impedance selection relay is 100 mA or less. When the USB port and the CONTACT INPUT terminal are used simultaneously, the CONTROL INPUT terminal signal will be the logical sum of both signals. Apply a signal appropriate for the terminal signal logic.



CAUTION Risk of malfunction.

- Isolate the contact signal control circuit from the internal circuit of this product with a photocoupler, and use an open-collector circuit.

Installing the driver

- 1 Set the supplied CD-ROM (API-USBP (WDM) driver software) by CONTEC) in the PC's CD drive.**
- 2 Check that the USB cable is connected properly between the product's USB port and PC.**
- 3 Turn on the POWER switch of this product.**

"Found new hardware wizard" starts.

If the wizard does not start automatically, install the driver by double-clicking Setup.exe in the "X:\INF\WDM\Dio" folder (where X is the CD-ROM drive) in the CD-ROM and clicking "API-DIO (VDM) Installer."
- 4 Select "Install the software automatically," and click Next.**

The driver installation begins.
- 5 When the installation is complete, click Finish.**

Checking the feature

Use the software (CONTEC API-USBP (WDM)) supplied with the DIO, and check that the product can be controlled through the USB port.

For details on using the diagnosis program for checking the operation, see the Isolated Digital I/O Terminal for USB2.0 DIO-0808LY-USB User's Guide.

Starting the diagnosis program

- 1 On your PC, choose Computer, Properties, and then Device Manager. “CONTEC Devices” appears in the Device Manager window.

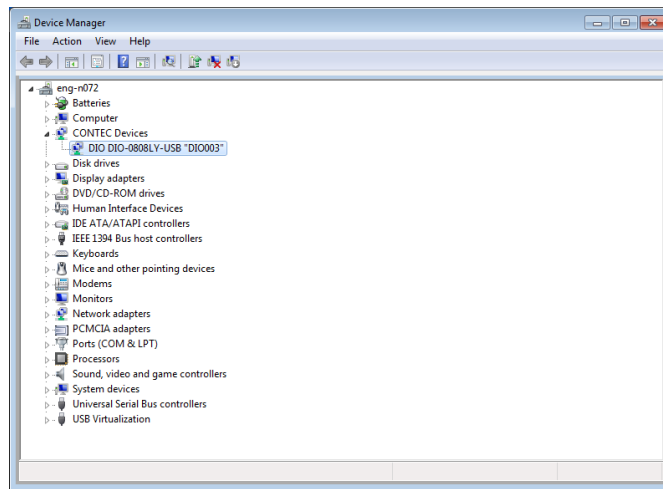

- 2 Right-click CONTEC Devices-DIO DIO-0808LY-USB, and then click Properties.

DIO DIO-0808LY-USB “DIO1000” Properties appear.

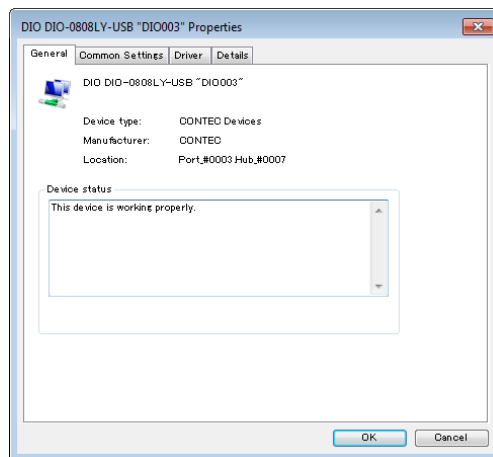

- 3 Click Diagnosis on the Common Settings tab.

The diagnosis program starts.

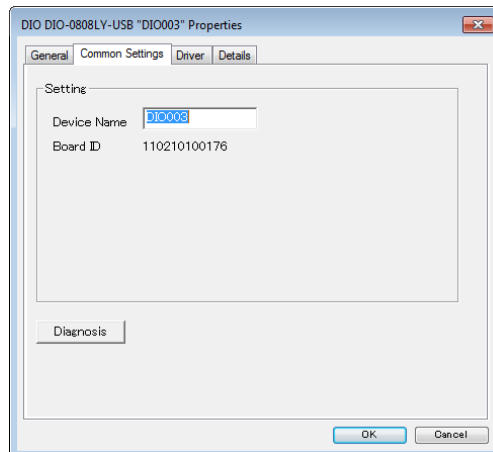

Checking the output port operation

By controlling specific bits, you can check whether the impedance can be switched properly.

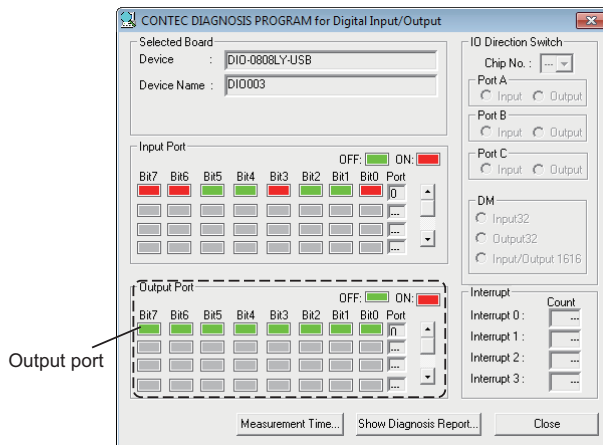

Click the bits in the output port to change the internal I/O port output. To switch the impedance, set the appropriate bits by referring to the following table.

Impedance	Bit7	Bit6	Bit5	Bit4	Bit3	Bit2	Bit1	Bit0
Z1	0	1	—	—	—	0	0	1
Z2	0	1	—	—	—	0	1	0
BYPASS	1	1	—	—	—	0	0	0

0: OFF (OPEN); displayed in green
 1: ON (LOW); displayed in red
 —: N/A

Checking the input port operation

You can check the product status.

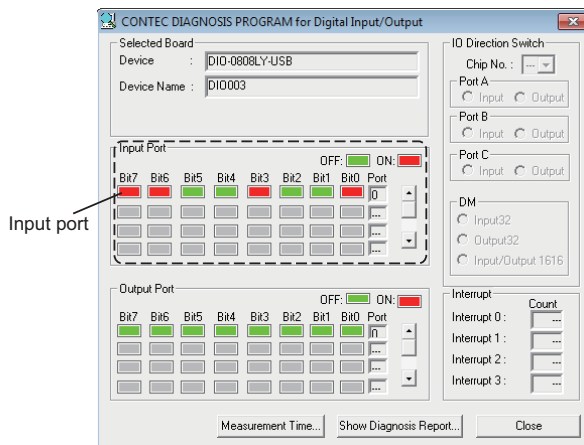

To do so, use the input port.

Status	Bit7	Bit6	Bit5	Bit4	Bit3	Bit2	Bit1	Bit0
LOCAL	1	1	—	—	0	0	0	1
REMOTE enabled	1	1	—	—	1	0	0	1
Overheat alarm activated (in LOCAL mode)	1	1	—	—	0	1	0	1
Overheat alarm activated (when REMOTE is enabled)	1	1	—	—	1	1	0	1

0: OFF (OPEN); displayed in green
 1: ON (LOW); displayed in red
 —: N/A

6 Specifications

This chapter lists the electrical and mechanical specifications of the product.

Item		Specifications	
Compliant standards		JIS C61000-3-2(2011), JETGR0003-1-2.0(2011), JIS C8962(2008), IEC 61000-3-3(2008)	
Reference impedance	Supported wiring systems	Single-phase two-wire, single-phase three-wire, three-phase three-wire, and three-phase four-wire	
	Impedance value	U, V, and W phases	Z1, Z2: 0.19 Ω + 0.23 mH Bypassing of each phase impedance is possible.
		N phase	Z1:0.21 Ω + 0.14 mH, Z2:0.19 Ω + 0.23 mH, Impedance bypassing is possible.
	Impedance error ¹	Resistance	\pm 5 %
		Reactance	\pm 5 % (50 Hz/60 Hz), \pm 15 % (reference value at 1 kHz), \pm 20 % (reference value at 3 kHz)
	Residual resistance during bypass	Each phase	10 m Ω or less
	Maximum rated voltage	Phase voltage	300 Vrms
		Line voltage	500 Vrms
	Maximum rated current	Each phase	60 Arms (continuous)
	Rated frequency		50 Hz/ 60 Hz (Z1, Z2)
Input and output terminals		Terminal block, M6 screws	
Control features	Voltage monitor output	Output voltage	CT output for monitoring the current of each phase Output voltage 12.5 mV/A built-in 25 Ω terminator)
		Current/voltage conversion error	\pm 1.5 % or less (50 Hz/60 Hz, at maximum rated current)
		Terminal	BNC (common terminal isolated from the internal circuit)
	Voltage sensing		Supports the hardware sensing functions of the PCR-LE and PCR-LE2 series using the internal sensing points of each phase
		Terminal	For U-N, V-N, and W-N phases, terminal block, M3 screws
	Contact signal control		Impedance selection using contact signals
		Operation current	Approx. 100 mAdc (24 Vdc open voltage or less) per circuit; internal relay operates through current absorption by the open-collector circuit
	Status output		Status output using contact signals
		Contact rating	5 Adc, 35 Vdc Contact connected to the internal circuit common when shorted
	USB remote control ²		Impedance selection and status querying using an isolated digital I/O terminal
		Controller	DIO0808LY-USB by CONTEC Complies with USB2.0 HighSpeed (480 Mbps) and USB1.1
		USB port	Type B
	PCR control		If PCR control is used with the PCR-L/LA/LE/LE2 series, the AC power supply output can be turned off when overheat protection is activated.
		Output terminal	Mini-Din6P female
	Protection functions		If PCR control is used with the PCR-L/LA/LE/LE2 series, when abnormal resistor temperature is detected, the ALARM indicator lights, a make contact signal is transmitted to turn off (open) all phases at once. Cooling operation continues.
Operation when the control power supply turns off		All phase outputs are turned off (opened) at once.	

Item		Specifications
Cooling method		Forced air
Control power supply	Nominal input rating	Single-phase 100 Vac, 120 Vac, 200 Vac, or 240 Vac (switch type) 50 Hz/60 Hz, approx. 500 VA or less
	Input voltage range	Within $\pm 10\%$ of the nominal input voltage rating
	Input terminal	Terminal block, M4 screws
Environmental conditions	Installation location	Indoors, altitude of up to 2000 m, overvoltage category II
	Temperature and humidity range in which specifications are guaranteed	23 °C \pm 5 °C (73.4 °F \pm 41 °F)
	Operating temperature and humidity range	0 °C to 50 °C (32 °F to 122 °F), 20 %rh to 80 %rh (no condensation)
	Storage temperature and humidity range	-20 °C to 70 °C (-4 °F to 158 °F), 90 %rh or less (no condensation)
Withstanding voltage	Control power supply input to case,	1.5 kVac for 1 minute
Insulation resistance	Input to case, Output to case, Current monitor output to I/O	100 M Ω or greater at 500 Vdc
External dimensions		See the outline drawing
Weight		Approx. 170 kg (375 lbs)
Earth continuity	Protective conductor terminal to case	25 Aac 0.1 Ω or less (control power supply terminal) No damage at 120 Aac for 1 minute (protective ground terminal G of the I/O terminal)
Safety		Complies with the requirements of the following standard. IEC61010-1:2001 (Class I ³ , Pollution degree 2 ⁴)
Accessories	Control cable	1 pc.
	Control board	1 card
	Control power cable	1 pc.
	Screws ⁵	12 pcs.
	Heavy object warning label	1 pc.
	Operation Manual	1 copy
	CD-ROM ² API-USBP (WDM) driver software by CONTEC	1 disc

- 1 Between each of the internal sensing points and the OUTPUT terminal when using the sensing function of the PCR-LE or PCR-LE2 series AC power supplies
- 2 Only on models with the USB interface
- 3 This product confirms to Class I. Be sure to ground the protective conductor terminal of this product. If not grounded properly, safety is not guaranteed.
- 4 Pollution is addition of foreign matter (solid, liquid or gaseous) that may produce a reduction of dielectric strength or surface resistivity. Pollution Degree 2 assumes that only non-conductive pollution will occur except for an occasional temporary conductivity caused by condensation.
- 5 Used when the rack mount bracket is removed

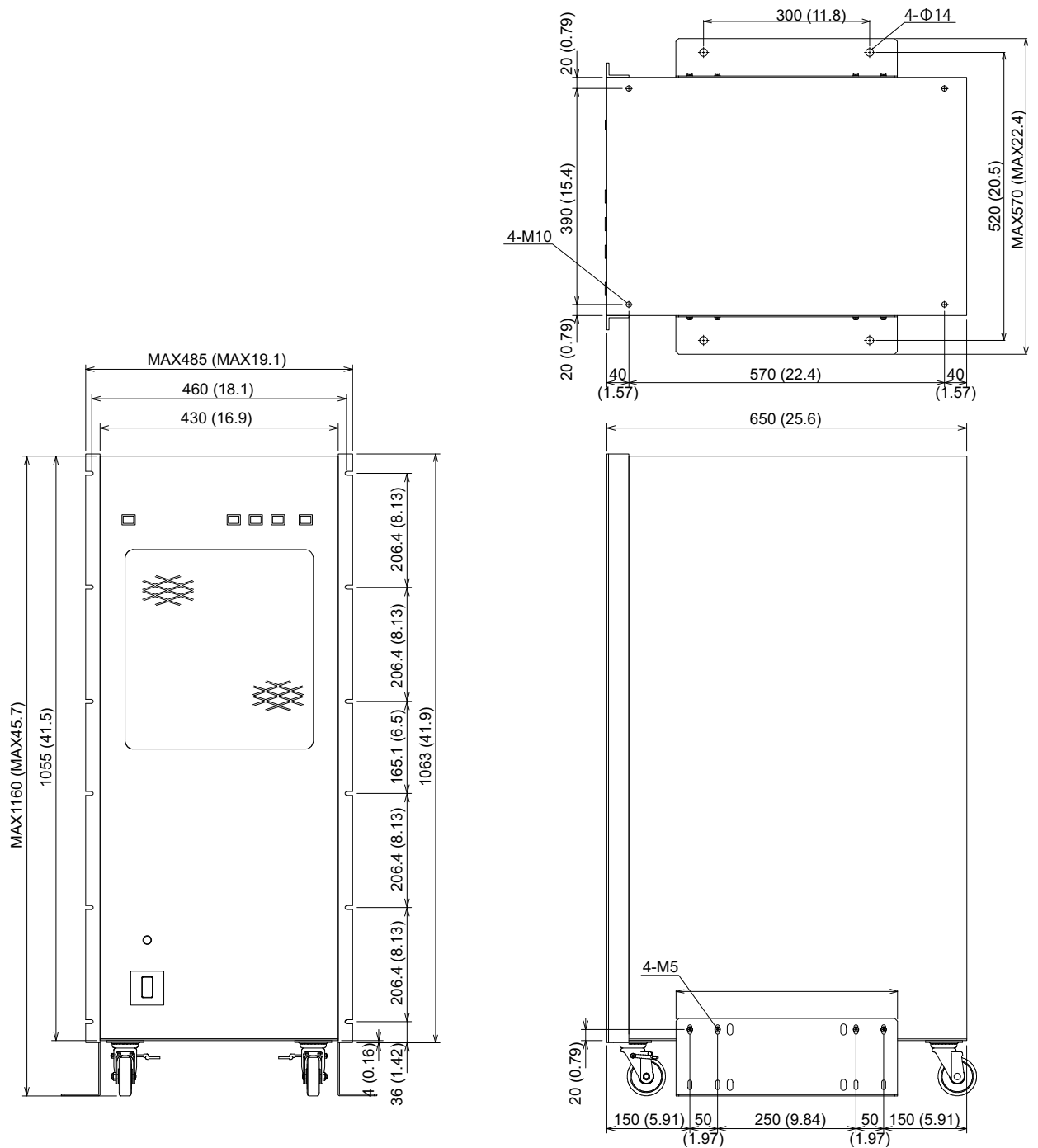

Unit: mm (inches)

LIN3060J outline drawing

Appendix A Troubleshooting

This section introduces troubleshooting measures. Check whether any of the items listed below apply to your case. If following the remedy does not solve your problem, contact your Kikusui agent or distributor.

Symptom	Inspection	Remedy	
The operation is unstable.	The product's supply voltage selector is set to a 200 V system (200 V or 240 V), but the product is mistakenly connected to a 100 V system nominal power supply.	<ul style="list-style-type: none"> Set the supply voltage selector appropriately according to the nominal supply voltage that is being used. When using a 100 V system nominal voltage, set the supply voltage selector to 100 V or 120 V. 	p. 18 , p. 34
Voltage is not applied to the EUT.	The product's POWER switch is turned off.	<ul style="list-style-type: none"> Turn on the POWER switch. 	p. 34
	The AC power supply output is turned off.	<ul style="list-style-type: none"> Turn on the AC power supply output. 	—
	The impedance is not selected.	<ul style="list-style-type: none"> The impedance switches are not interlocked. Therefore, turn off all switches first, and then press the appropriate switch. 	p. 35
Impedance cannot be selected from the front panel.	The product's remote control switch is turned on (the button is pressed in).	<ul style="list-style-type: none"> Turn off the product's remote control switch (release the button). 	p. 38
The ALARM indicator is lit.	The product's ALARM indicator is lit.	<ul style="list-style-type: none"> The temperature inside the product is too high. Allow the product to cool down adequately. Turn off the AC power supply output. 	p. 37
Remote control does not work.	The illumination area of the REMOTE switch on the front panel is turned off.	<ul style="list-style-type: none"> Turn on the REMOTE switch on the front panel. 	p. 38
	The illumination area of the REMOTE switch on the front panel is turned on.	<ul style="list-style-type: none"> Enable the remote signal. The product switches to remote control mode when the REMOTE switch is on and the remote signal is being received. 	p. 38
The impedance error is large.	The AC power supply sensing terminal is not connected or has become disconnected.	<ul style="list-style-type: none"> Connect the AC power supply sensing terminal securely. 	p. 17
	It cannot be used with the PCR-LA, PCR-L, or AC power supplies made by other manufacturers.	<ul style="list-style-type: none"> Make sure that the wires used between the AC power supplies and the input terminal of the LIN3060J meet the specified conditions (nominal cross-sectional area and maximum length). 	p. 21

Appendix B Connecting the PCR-LE and PCR-LE2

This section describes how to use the output terminal of the PCR-LE and PCR-LE2 AC power supplies. The following description is for connecting the AC power supplies to the LIN3060J. For other details, see the PCR-LE or PCR-LE2 manual.



Risk of electric shock.

- **To prevent electric shock, be sure to attach the transparent cover on the rear panel of the AC power supplies. High voltage will be applied to the terminals.**
 - **Before you connect cables to the AC power supplies' OUTPUT terminal blocks, be sure to turn the POWER switch off, and then shut off the power supply from the switchboard.**
 - **Be sure to ground the AC power supplies to prevent electric shock.**
 - **Never connect the INPUT terminal block of the LIN3060J to the AC line. The internal circuit of the LIN3060J is not designed to be connected to the AC line.**
 - **Fasten the terminal screws securely. Loose screws are dangerous because the cables may come loose or the connection may heat up.**
-

Output terminal

The screw size of the output terminal block varies depending on the model.

Model	Terminal block screw size
	Single-phase output
PCR1000LE	M4
PCR2000LE	M4
PCR3000LE	M5
PCR4000LE	M5
PCR6000LE	M6
PCR9000LE	M6

Single-phase two-wire output

- 1 Pull out the OUTPUT Terminal block from the bottom of the AC power supply's rear panel.**

To connect cables to the OUTPUT terminal block of the AC power supply (PCR-LE series except the PCR500LE), the terminal block tray needs to be pulled out. For details, see the manual supplied with the AC power supply.

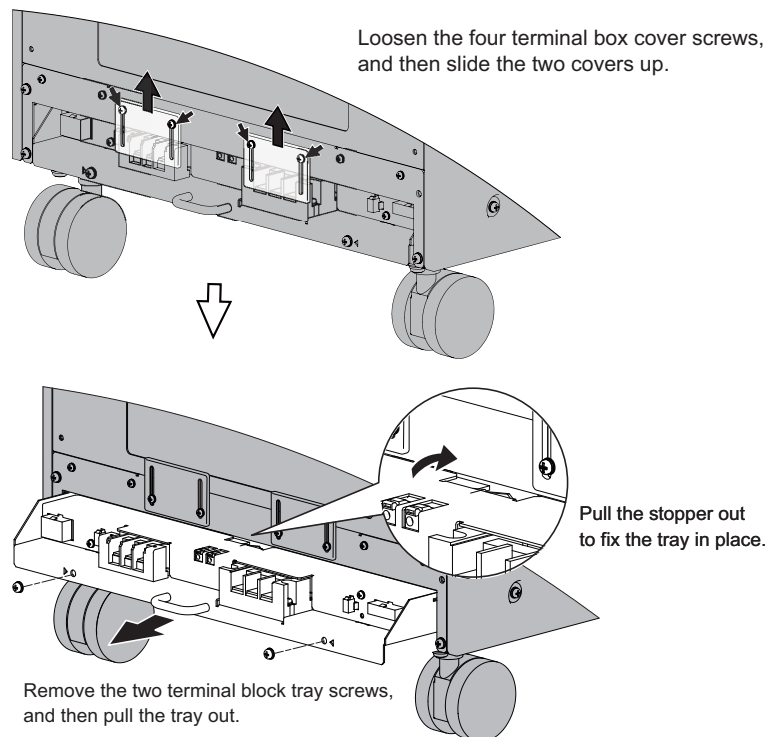

2 Connect the AC power supply's OUTPUT Terminal to the LIN3060J input terminal.

The following figures show a connection example.

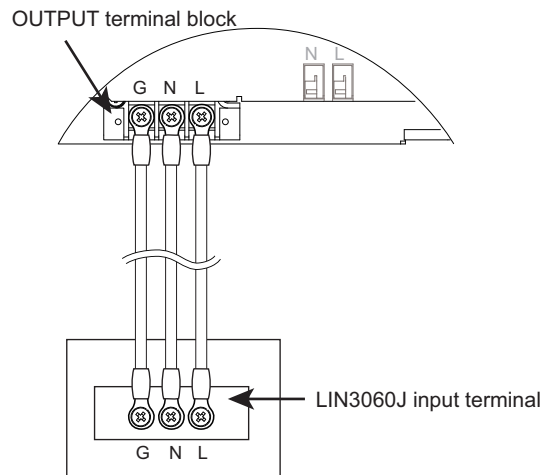

Sensing

The sensing functions that are equipped in the PCR-LE and PCR-LE2 series can be used to reduce the effects of output terminal wiring impedance. This simplifies the wiring when they are incorporated in the test system.

Screw-less terminals are used.

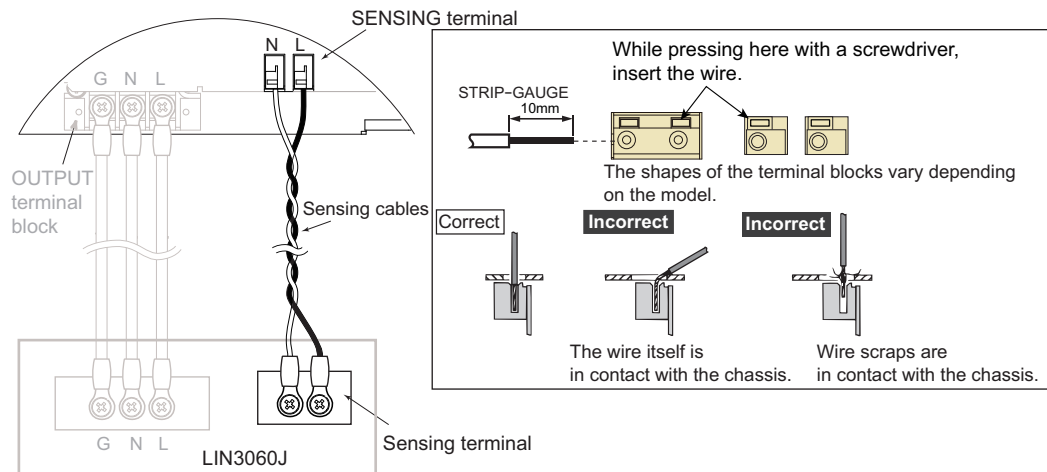

This section describes the PCR6000LE2 and PCR9000LE2. For details on the PCR27000LE2, see the PCR-LE2 series AC power supply setup guide or user's manual.

Output terminal

The screw size of the output terminal block varies depending on the model.

Model	Terminal block screw size		
	Single-phase output	Single-phase three-wire output	Three-phase output
PCR6000LE2	M8	M5	M5
PCR9000LE2	M8	M5	M5
PCR27000LE2	M8	M8	M8

Single-phase two-wire output

- 1 Pull out the OUTPUT Terminal block from the bottom of the AC power supply's rear panel.**

To connect cables to the OUTPUT terminal block of the AC power supply, the terminal block tray needs to be pulled out. Loosen the six terminal box cover screws, and then slide the three covers up.

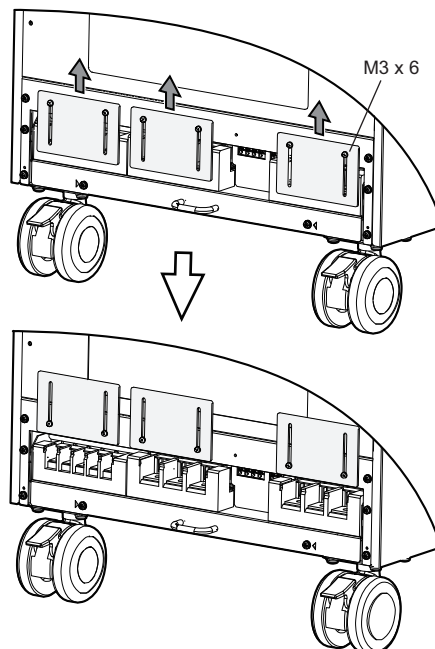

- 2 Remove the two terminal block tray screws, and then pull the tray out.**
Pull out the stopper to lock the terminal block tray in place.

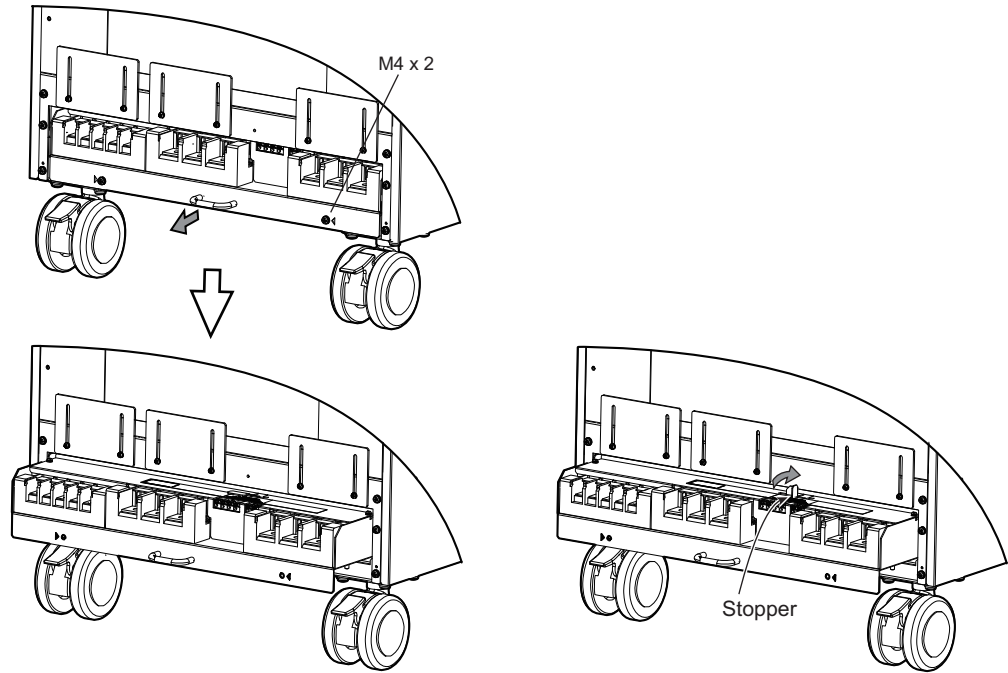

3 Connect the AC power supply's OUTPUT Terminal to the LIN3060J input terminal.

The connection to the AC power supply OUTPUT terminal is shown in the figure below.

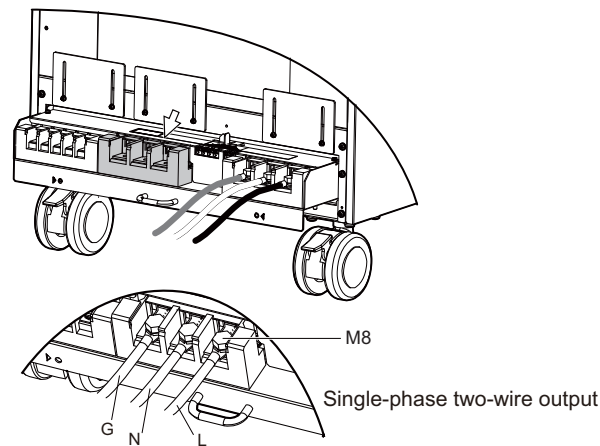

Single-phase three-wire, three-phase three-wire, and three-phase four-wire output

1 Pull out the OUTPUT Terminal block from the bottom of the AC power supply's rear panel.

The procedure for pulling out the OUTPUT terminal block is the same as with the single-phase two-wire output terminal.

2 Connect the AC power supply's OUTPUT Terminal to the LIN3060J input terminal.

The connection to the AC power supply OUTPUT terminal is shown in a figure on the next page.

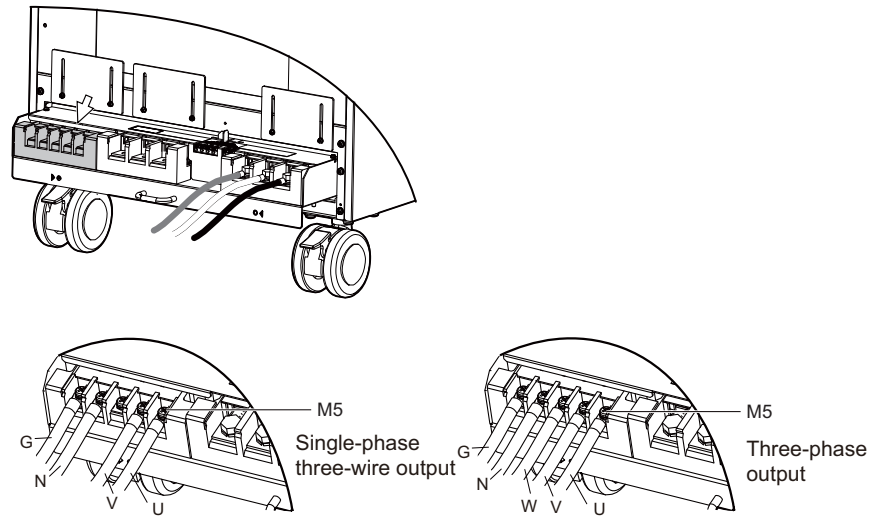

Sensing

The sensing functions that are equipped in the PCR-LE and PCR-LE2 series can be used to reduce the effects of output terminal wiring impedance. This simplifies the wiring when they are incorporated in the test system.

See p. 51

Screw-less terminals are used (the same as with the PCR-LE AC power supplies).

The figure below shows wiring examples for a single-phase two-wire circuit and three-phase four-wire circuit.

■ Single-phase two-wire circuit

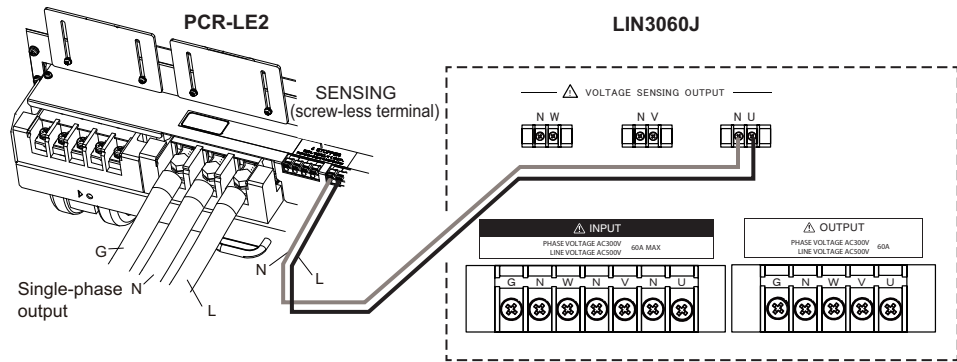

■ Three-phase four-wire circuit

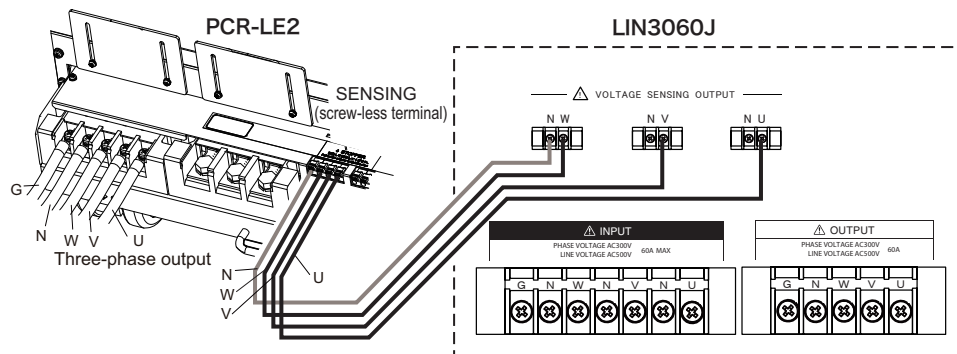

Appendix C KHA3000 Input Terminal

This section describes how to use the KHA3000 input terminal. One phase (input channel) is described. For details on each phase, see the KHA3000 operation manual.

■ Voltage input terminal

Use input terminal V and input terminal \pm to connect to the EUT. We recommend that you use UL1015 wires or equivalent with a wire size of AWG18. Strip 10 mm of insulation. To secure the wires in place, use the screwdriver supplied with the KHA3000 to fasten the terminal screws. Twist the wires as much as possible.

■ Current input terminal

There are SOURCE and LOAD terminals. Connect the SOURCE terminal to the impedance output and the LOAD terminal to the EUT.

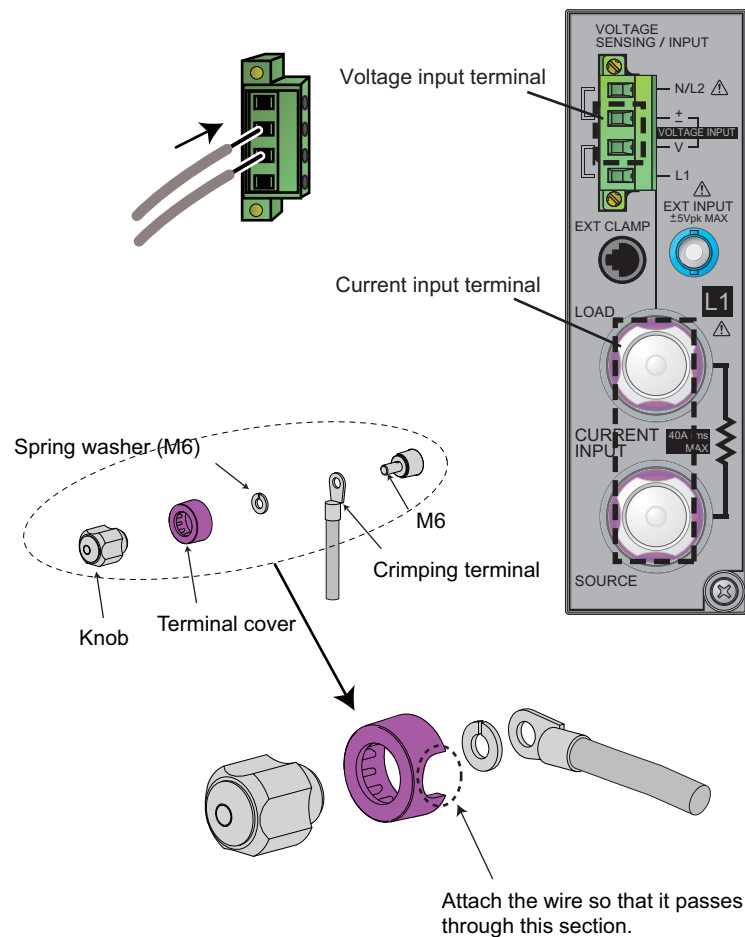

Delta transformation (star-delta transformation)

The delta transformation feature is used to convert phase voltage measurements of three-phase four-wire circuits to line voltages. Therefore, even if the actual circuit is wired using a three-phase four-wire system, line voltage measurement of a three-phase three-wire system is possible. The following figure shows a three-phase three-wire circuit and three-phase four-wire circuit used to test a three-phase three-wire EUT.

You can set the delta transformation using the wiring system menu. For details, see the KHA3000 operation manual.

Three-phase three-wire circuit

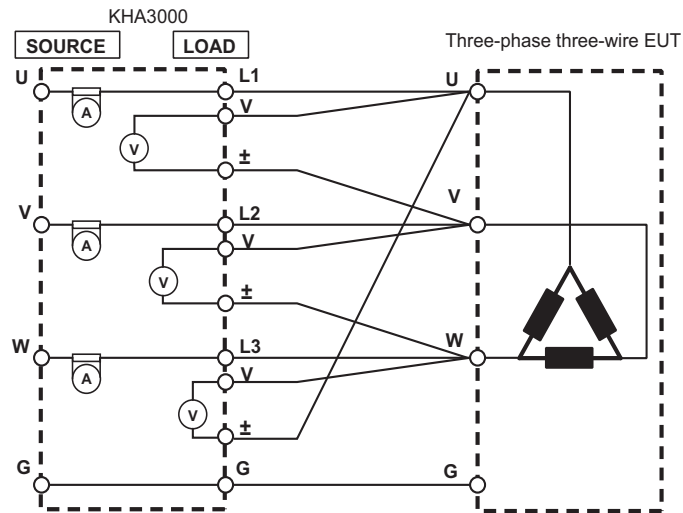

Three-phase four-wire circuit

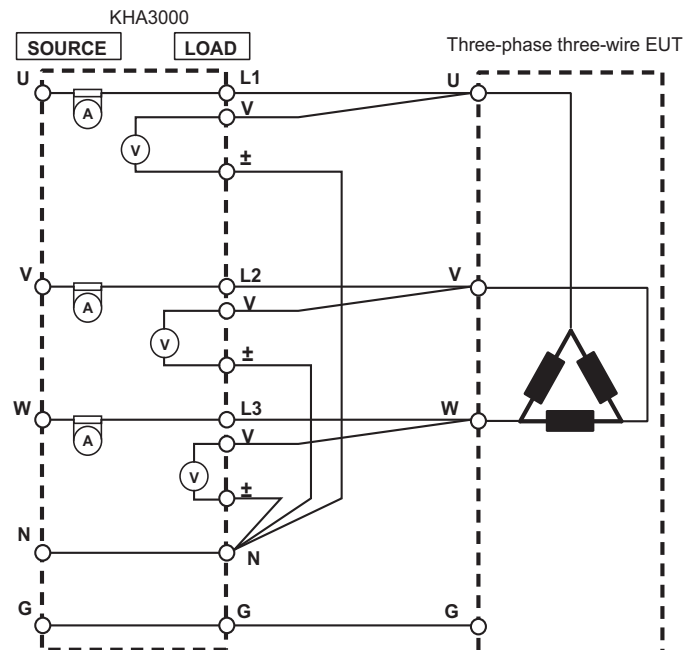

Index

A	
AC INPUT	16, 18
ALARM indicator	15
B	
base hold angle	7
BYPASS	15, 39
C	
caster lock lever	7
contact signal control, example	40
CONTRL INPUT	16
control board	32
CONTROL INPUT	19
CT OUTPUT	16, 17
D	
delta transformation (star-delta transformation)	56
driver, installation	42
E	
external dimensions	46
eye bolt screw hole	8
F	
Factory option	41
I	
If	34
impedance, selecting	35
INPUT	16
INPUT VOLTAGE	16
INPUT VOLTAGE (supply voltage) selector	18, 20, 34
L	
LIN OVERHEAT (overheat alarm)	40
O	
operating temperature and humidity range	46
OUTPUT	16
overheat alarms, handling	37
P	
parts to have ready	21
PCR CONTROL	16, 18
POWER switch	15
R	
REMOTE	15, 39
remote control, switching	38
S	
Sensing	17, 21
sensing	54
sensing function, if it cannot be used	21
single phase	22
single-phase	28
single-phase, single-phase three-wire	24
single-phase, three-phase	26, 30
STATUS OUTPUT	16, 19
storage temperature and humidity range	46
T	
temperature range in which specifications are guaranteed	46
test circuit	21
U	
USB	16
USB port (factory option)	41
V	
VOLTAGE SENSING OUTPUT	16, 17
Z	
Z1	15, 39
Z2	15, 39



环境保护使用期限
Environment-friendly Use Period

该标记为适用于在中华人民共和国销售的电子信息产品的环境保护使用期限。

只要遵守有关该产品的安全及使用注意事项，从制造年月起计算，在该年度内，就不会对环境污染、人身、财产产生重大的影响。

产品的废弃请遵守有关规定。

产品的制造年月可以在以下网址中确认。

<http://www.kikusui.co.jp/pi/>

有毒有害物质或元素名称及含有标示
Name of hazardous materials and symbol of element in the equipment and quantity

部件名称	有毒有害物质或元素					
	铅 Pb	汞 Hg	镉 Cd	六价铬 Cr(VI)	多溴联苯 PBB	多溴二苯醚 PBDE
印刷电路板组装机	×	○	×	○	○	○
内部接线	×	○	×	○	○	○
外壳	×	○	×	○	○	○
底盘组装机 (含变压器)	×	○	×	○	○	○
辅助设备	×	○	×	○	○	○

本表格依据SJ/T 11364 的规定编制。

○: 该部件所有均质材料的有毒有害物质的含量不超过GB/T 26572 标准所规定的极限值要求。

×: 该部件至少有一种均质材料的有毒有害物质的含量超过GB/T 26572标准所规定的极限值要求。

If you find any misplaced or missing pages in the manuals, they will be replaced. If the manual gets lost or soiled, a new copy can be provided for a fee. In either case, please contact your Kikusui agent or distributor. At that time, inform your agent or distributor of the "Part No." written on the front cover of this manual.

Every effort has been made to ensure the accuracy of this manual. However, if you have any questions or find any errors or omissions, please contact your Kikusui agent or distributor.

After you have finished reading this manual, store it so that you can use it for reference at any time.

KIKUSUI ELECTRONICS CORP.

1-1-3 Higashiyamata, Tsuzuki-ku, Yokohama,
224-0023, Japan
Tel: +81-45-593-7570 Fax: +81-45-593-7571



Website

<http://www.kikusui.co.jp/en>