

**KIKUSUI**

PART NO. Z1-006-130, I0021301

Aug 2020

Setup Guide

AC Power Supply PCR-LE2 series

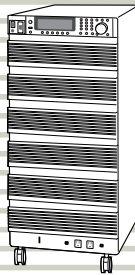
PCR6000LE2(500HZ LMT)**PCR9000LE2(500HZ LMT)****PCR12000LE2(500HZ LMT)****PCR18000LE2(500HZ LMT)****PCR27000LE2(500HZ LMT)**

Thank you for purchasing the PCR-LE2 Series AC Power Supply.

The PCR-LE2 Series is a special version of the PCR-LE Series that can produce highly pure AC signals through the combination of its high-speed linear amplifier and arbitrary waveform synthesizer. It features switchable single-phase, single-phase three-wire, and three-phase outputs.

During three-phase output, the PCR-LE2(500HZ LMT) limits the maximum output frequency to 500 Hz.

Checking the Package Contents

When you receive the product, check that all accessories are included and that the accessories have not been damaged during transportation. If any of the accessories are damaged or missing, contact your Kikusui agent or distributor. We recommend that you save all packing materials, in case the product needs to be transported at a later date.

Accessory

	Accessory	QTY.	Note
<input type="checkbox"/>	Heavy object warning label	1	PCR6000LE2/PCR9000LE2 only [A8-900-158]
<input type="checkbox"/>	Setup Guide	1	
<input type="checkbox"/>	CD-ROM	1	
<input type="checkbox"/>	Quick Reference	English: 1 pc. Japanese: 1 pc.	
<input type="checkbox"/>	Safety information	1	

Features

The PCR-LE2 Series is equipped with the following features.

- Switchable between single-phase output, single-phase three-wire output, and three-phase output
Three types of output are available on a single unit.
- Various power supply simulations
Power line abnormalities such as outages and voltage dips can be simulated. This is a basic feature for power-supply-environment testing.
- Various measurements
The rms voltage and current, the peak voltage and current, the active power, apparent power, and power factor of the output can be measured. Harmonic analysis (up to the 40th harmonic) can be performed on the output current.
- DC output
The PCR-LE2 Series can generate DC output (single-phase output or single-phase three-wire output only) and AC + DC output (single-phase output only). This makes it possible to use the PCR-LE2 Series in a variety of fields, including chemistry and physics.
- Sequences
The output voltage, frequency, and waveform can be changed over time. Power-supply-environment testing can be automated. In addition to the AC output sequences, DC output (single-phase output or single-phase three-wire output only) and AC + DC output (single-phase output only) sequences are also available. A variety of standard tests can also be performed.
- Sensing and regulation adjustment
Even if the load device is at a remote location, the PCR-LE2 Series can stabilize the voltage across the load by correcting for voltage drops.
There are two types of sensing: hard sensing (single-phase output only) and soft sensing. The different types of sensing are used depending on the load conditions and how you will use the PCR-LE2 Series.
- Output current control
The output limit function can be used to limit the output current (rms) to a fixed value to perform continuous operation. Continuity tests on electrical equipment (such as switchboards, breakers, and wiring devices) can be performed under stable conditions.
- Power management function (power saving function)
A sleep function, which turns the power units off to reduce power consumption when output is not generated for the specified length of time, and a power-saving function, which operates the power units at the bare minimum settings as required by the supply load, are available.
- Memory function
Up to 99 entries of output frequency, voltage (AC or DC), and waveform bank settings can be saved to the internal memory.
The contents of internal memory, panel settings, power line abnormality simulations, sequence data, and waveform bank data can be saved to a USB memory device.
- External communications
The PCR-LE2 Series can be controlled remotely through its RS232C interface. If an optional interface board is used, the PCR-LE2 Series can be controlled remotely through USB, GPIB, and LAN interfaces.
- External analog signal control (optional)
The EX05-PCR-LE/EX06-PCR-LE option enables you to control the PCR-LE2 Series output using external analog signals.

KIKUSUI ELECTRONICS CORP.

1-1-3 Higashiyamata, Tsuzuki-ku, Yokohama,
224-0023, Japan

Tel: +81-45-482-6353

Fax: +81-45-482-6261

www.kikusui.co.jp/en



About the PCR-LE2 Documentation

These manuals are intended for users of the PCR-LE2 Series AC Power Supply and their instructors.

Explanations are given under the presumption that the reader has knowledge related to electric safety tests.

You can view the PDF file using Adobe Reader 6.0 or later.

The HTML can be viewed using the following browser.

Browser: Microsoft Internet Explorer 9.0 or later

Every effort has been made to ensure the accuracy of this manual. However, if you have any questions or find any errors or omissions, please contact your Kikusui agent or distributor.

If you find any misplaced or missing pages in this manual, it will be replaced. If the manual gets lost or soiled, a new copy can be provided for a fee. To replace or purchase a manual, please contact your Kikusui agent or distributor. At that time, inform your agent or distributor of the "Part No." written on the front cover of this manual.

After you have finished reading this manual, store it so that you can use it for reference at any time.

Notations used in the PCR-LE2 manual

In the PCR-LE2 manual, the PCR-LE2 Series AC Power Supply is also referred to as the PCR-LE2 Series and the PCR-LE2.

The term "PC" is used to refer generally to both personal computers and workstations.

The screen captures used in this manual may differ from the actual screens that appear on the PCR-LE2. The screen captures are merely examples.

The following markings are used in the explanations in the manual.

⚠ WARNING
Indicates a potentially hazardous situation which, if ignored, could result in death or serious injury.

⚠ CAUTION
Indicates a potentially hazardous situation which, if ignored, may result in damage to the product or other property.

- Note -
Indicates information that you should know.

- DESCRIPTION -
Explanation of terminology or operation principle.

(SHIFT+key name)

Indicates an operation that requires you to press a key indicated in blue characters (the lower row of text to the left of the key) while holding down the SHIFT key.

Contents of the Included CD-ROM

Put the included CD-ROM into the CD-ROM drive. In a few moments, a start window will appear. If the start window does not appear, open the CD-ROM folder in Windows Explorer, and then double-click index.html to display the start window.



Accompanying CD-ROM contains following the items.

- KI-VISA x.x.x
- IVI-COM
- Operation Manual

Click the "See the Manual" to move to the Manual page.

Documentation Structure

The PCR-LE2 Series manual comprises the following documentation.

■ User's Manual -Basic-

- Front panel and Rear panel
- Panel Operation Basics
- Selecting the Output Mode
- Setting the Output Voltage/ Frequency
- Turning Output On and Off
- Displaying Measurement Values
How to switch the display of measured value.
- Setting Limits
Limits can be placed on the PCR-LE2 output voltage setting and frequency setting. They prevent damage to the load caused by mistaken operations and limit the current that flows through the load. You can set limits in advance according to the load conditions.
- Using Protection Functions
The PCR-LE2 has the following protection functions.
Input voltage drop protection
Overheat protection (OHP)
Overload protection
Internal semiconductor protection (OCP)
Output undervoltage protection (UVP)
Output overvoltage protection (OVP)
- Using Memory
You can store data to the PCR-LE2's internal memory and save data to a USB memory device.

■ User's Manual -Specifications-

Specifications contains the electrical specifications and outline drawings.

■ User's Manual -Appendix-

- Glossary, Operation Characteristics, Output and load
- Peak hold current measurement
- Sequence tutorial
- Option
- Factory Default Settings
- Maintenance
- Troubleshooting
- Alarms and Trouble
- Error Message

■ Setup Guide (This guide)

This guide is intended for first-time users of the product. It gives an overview of the product, connecting procedures, etc. Please read through and understand this guide before operating the product.

■ Quick Reference

The quick reference briefly explains the panel description and the basic operation of the product.

■ Safety information

This document contains general safety precautions for this product. Keep them in mind and make sure to observe them.

■ Programming Sheet

- Table for Recording Power Line Abnormality Simulation Operation Settings (XLS)
- Table for Recording Sequence Operation Settings (XLS)

■ User's Manual -Advanced-

- Using the synchronization Function
The synchronization function synchronizes the frequency and phase of the PCR-LE2 output voltage with a 50 Hz or 60 Hz input power supply.
- Using the Voltage Compensation Function
The compensation function compensates for voltage drops in the load cables when the load is connected to the PCR-LE2 over a long distance.
- Using Power Line Abnormality Simulations
In AC mode, you can simulate power supply line errors by stopping the PCR-LE2 output and decreasing and increasing the voltage (to simulate voltage dips and pops).
- Using the Sequence Function
A sequence is a series of settings - values such as the output voltage, frequency, and time - that are saved in advance and are then recalled and automatically carried out in order at a later time.
- Using the Harmonic Current Analysis Function
You can perform harmonic analysis of the output current.
- Generating Special Waveforms (Waveform bank)
You can generate peak-clipped sine waveforms.
- Setting the Output Impedance
The PCR-LE2 output impedance (output resistance) is approximately 0Ω . Commercial power supplies have an impedance (resistance) of several milliohms to several ohms. You can set the PCR-LE2 output impedance. This enables you to simulate the same environment as that which is provided by commercial power supplies.
- Setting Soft Starts (The voltage rise time)
To prevent the output from being turned off (the alarm from being activated) and the voltage from dropping due to the load device's inrush current that exceeds the rated capacity of the PCR-LE2, you can control the inrush current by having the output voltage rise gradually when the output is turned on.
- Fixing the Internal Vcc
To minimize loss in the linear amplifier section, the PCR-LE2 automatically adjusts the linear amplifier supply voltage (Vcc) to a level that is suitable for the output voltage. You can fix the Vcc voltage of the PCR-LE2. This is useful when you want to prioritize the output voltage response over the product's efficiency.
- Selecting the Response
The PCR-LE2 uses a high-speed amplifier. Depending on the load circuits (especially in the case of capacitive loads) and the wiring conditions, the output may become unstable may oscillate. You can set the response speed of the internal amplifier according to the load conditions and how you will use the PCR-LE2.
- Using the Power Management Functions
The PCR-LE2 has the following two power management functions: a sleep function and a power-saving function
- External analog signal control (optional)
You can use the optional analog signal interface board to control the product with external analog signals.

■ Communication Interface Manual

This manual contains details about remote control.

Interface manual is written for readers with sufficient basic knowledge of how to control instruments using a personal computer.

PCR-LE2 Series models

The PCR-LE2 Series generates single-phase output. The following models are available

Model	Rated output capacity		Maximum output current			
	Single-phase, Three-phase	Single-phase three-wire	Single-phase		Single-phase three-wire, Three-phase	
			100 V output	200 V output	100 V output	200 V output
PCR6000LE2	6 kVA	4 kVA	60 A	30 A	20 A	10 A
PCR9000LE2	9 kVA	6 kVA	90 A	45 A	30 A	15 A
PCR12000LE2	12 kVA	8 kVA	120 A	60 A	40 A	20 A
PCR18000LE2	18 kVA	12 kVA	180 A	90 A	60 A	30 A
PCR27000LE2	27 kVA	18 kVA	270 A	135 A	90 A	45 A

This product consists of three power unit groups.

Model	Output capacity per group
PCR6000LE2	2 kVA
PCR9000LE2	3 kVA
PCR12000LE2	4 kVA
PCR18000LE2	6 kVA
PCR27000LE2	9 kVA

During single-phase output, all groups are used.

During single-phase three-wire output or three-phase output, each phase (U, V and W) is assigned to a separate group.

During single-phase three-wire output, the phase W group is not used. During three-phase output, all groups are used.

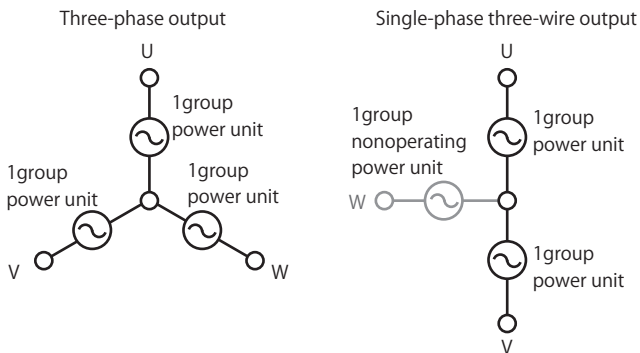

Precautions Concerning Installation

When installing this product, be sure to observe the precautions provided in "Precautions Concerning Installation Location" in the Safety information manual. Items specific to this product are given below.

- When you install the product, be sure to observe the temperature and humidity ranges indicated below.
 - Operating temperature range: 0 °C to 50 °C (32 °F to 122 °F)
 - Operating humidity range: 20 %rh to 80 %rh (no condensation)
- When you store the product, be sure to observe the temperature and humidity ranges indicated below.
 - Storage temperature range: -10 °C to 60 °C (14 °F to 140 °F)
 - Storage humidity range: 90 %rh or less (no condensation)
- Allow at least 20 cm of space between the air inlet/outlet and the wall (or obstacles).
- Fix PCR6000LE2s and PCR9000LE2s to the floor using L-shaped or other similar brackets.
 - Base Hold Angles (OP03-KRC) are available as options.

Moving the product

Precautions when moving the PCR6000LE2/ PCR9000LE2

Note the following points when moving the product to the installation location or when transporting the product.

- Raise the stopper.
 - Moving the product with the stopper lowered may cause injuries due to the product falling over.
- Unlock the casters.
- Do not move the product by yourself.

Be sure to have two or more people move the product. Exercise special care when carrying the product over a slope or across steps.

Hold the product from underneath.

Check the product's weight before you transport it. The weight is displayed in the bottom of the rear panel.

If you are using a forklift, be sure to slide the forks under the bottom of the product, check that the product is stable, and then raise the product.

If you are using a band or similar item to raise the product with a crane, be sure to slide the band under the bottom of the product, check that the product is stable, and then raise the product.

- When you move the product, do not tip the product on its side or turn it upside down.

Locking the casters and using the stopper

This product has casters on its bottom side, so it is easy to move the product. To ensure that the product is not moved accidentally while it is being operated, use the stopper to fix the product in place, and lock the casters.

Looking down at the stopper from above, turning the stopper to the left (counterclockwise) raises the stopper, and turning the stopper to the right (clockwise) lowers the stopper.

Lowering the lock lever on a caster locks the caster, and raising the lock lever unlocks the caster.

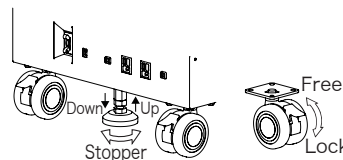

Precautions when moving the PCR12000LE2/ PCR18000LE2/ PCR27000LE2

The PCR12000LE2/ PCR18000LE2/ PCR27000LE2 cannot be moved after it has been installed. If you need to move it, contact your Kikusui agent or distributor.

Handling the Terminal Block Tray (PCR600LE2/ PCR9000LE2)

The PCR-LE2 Series AC INPUT, OUTPUT terminal block, SENSING terminal block, and J1 to J4 connectors are designed so that they can only be wired after you first pull out the terminal block tray. The terminal box covers ensure that you don't touch the unwired terminals. Use a Phillips-head screwdriver to insert and remove the screws.

1 Check that the **POWER** switch is turned off.

2 Loosen the six terminal box cover screws, and then slide the three covers up.

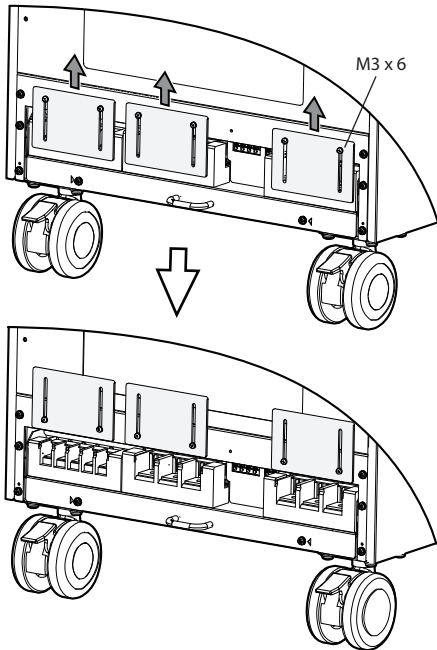

3 Remove the two terminal block tray screws, and then pull the tray out.

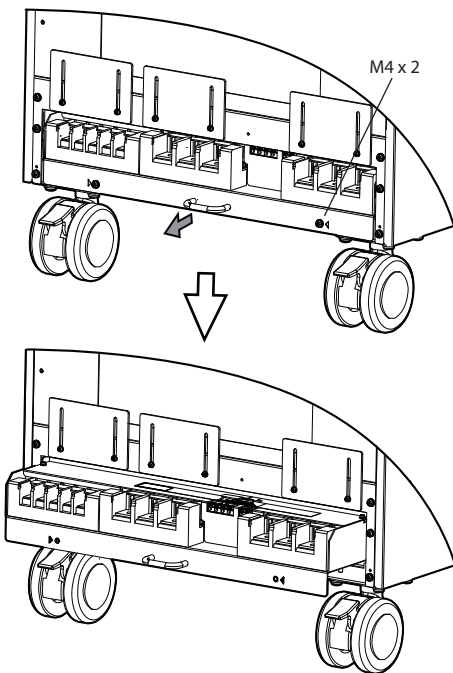

4 Pull out the stopper to lock the terminal block tray in place.

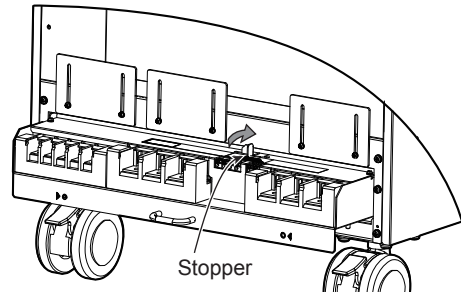

5 Connect the wires and cables to the terminal block and connectors as necessary.

6 Return the stopper to its previous position.

7 Return the terminal block tray to its previous position, and then attach the two screws that you removed in step 3

If you do not insert the terminal block tray all the way into its storage compartment, an electric current will not flow through the PCR-LE2 even if the POWER switch is turned on.

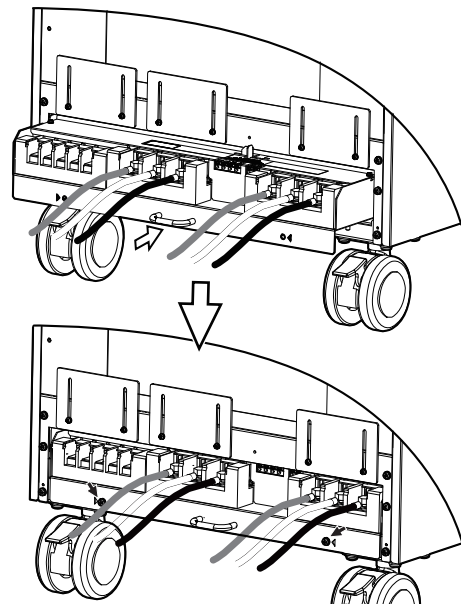

8 Slide the two terminal box covers down until they are touching the wires, and then use the four screws to fix the terminal box covers in place. Slide the terminal box cover all the way down if none of their terminals have wires connected to them, and use the two screws to fix the covers in place.

The figure below is an example for when the OUTPUT terminal blocks for single-phase output are in use.

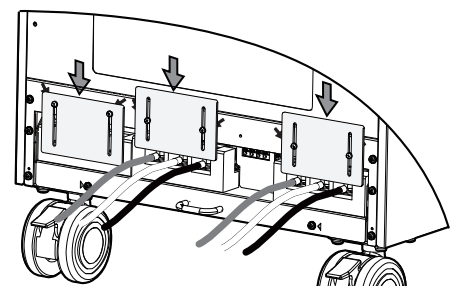

Connecting the power cord

This product conforms to IEC Overvoltage Category II (energy-consuming equipment that is supplied from a fixed installation).

WARNING

Risk of electric shock.

- This product conforms to IEC Safety Class I (equipment that has a protective conductor terminal). Be sure to earth ground the product to prevent electric shock.
- Connect the protective conductor terminal to earth ground.
- Turn off the circuit breaker of the switchboard before you connect the power cord.
- Do not use the product with the terminal box covers removed.

Risk of electric shock or fire.

- For the connected switchboard, select a breaker that has a cut-off current that can handle the maximum input current of the product
- Have a qualified engineer connect the power cord to the switchboard.

■ Tightening torque of input terminal connecting screws

	Tightening torque [N·m]
M5	2.0
M8	5.5

CAUTION

If the voltage distortion of the AC power line is large, the product may malfunction. The PCR-LE2 Series cannot be connected to a generator or a similar device.

Inside the product, protective circuits such as input fuses are connected to match the polarity of the input terminal. Be sure to match the colors of the wires and the input terminals to connect the wires correctly.

Single-phase, 200 V input (PCR6000LE2 only):

L, N, and  (GND)

Three-phase, 200 V input: R, S, T, and  (GND)

Three-phase, 400 V input: R, S, T, N, and  (GND)

- Note -

The POWER switch can be used to disconnect the product from the AC power line in an emergency (On the PCR27000LE2, the MASTER POWER switch and the two SLAVE POWER switches must be turned off.). Provide enough space around the POWER switch to ensure that it can be turned off at any time.

A power cord is not supplied with the PCR-LE2 Series.

Input power cords are available as options. When you are wiring the switchboard, attach crimping terminals that match the screws of the switchboard that has been connected by a qualified engineer.

If you will not use one of the optional input power cords, prepare a power cord that meets the following specifications.

	Cable	Nominal cross-sectional area	Input terminal
Single-phase, 200 V input	PCR6000LE2 Three single-core cables	14 mm ² or more	M8
Three-phase, 200 V input	PCR6000LE2	8 mm ² or more	M5
	PCR9000LE2	14 mm ² or more	M5
	PCR12000LE2	22 mm ² or more	M8
	PCR18000LE2	38 mm ² or more	M8
	PCR27000LE2	60 mm ² or more	M8
Three-phase, 400 V input	PCR6000LE2	5.5 mm ² or more	M5
	PCR9000LE2	5.5 mm ² or more	M5
	PCR12000LE2	8 mm ² or more	M8
	PCR18000LE2	14 mm ² or more	M8
	PCR27000LE2	38 mm ² or more	M8

Connecting power cords to the PCR6000LE2 or PCR9000LE2

1 Check that the AC power line meets the nominal input rating of the product.

The product can receive a nominal power supply voltage:
Single-phase, 200 V input (PCR6000LE2 only):
200 Vac to 240 Vac
Three-phase 200 V input: 200 Vac to 240 Vac (Line Voltage)
Three-phase, 400 V input: 220 Vac to 240 Vac (Phase Voltage)
Frequency: 50 Hz or 60 Hz.

2 Check that the POWER switch is turned off.

3 Pull out the terminal block tray.

4 Securely connect the power codes to corresponding terminals of AC INPUT terminal block.

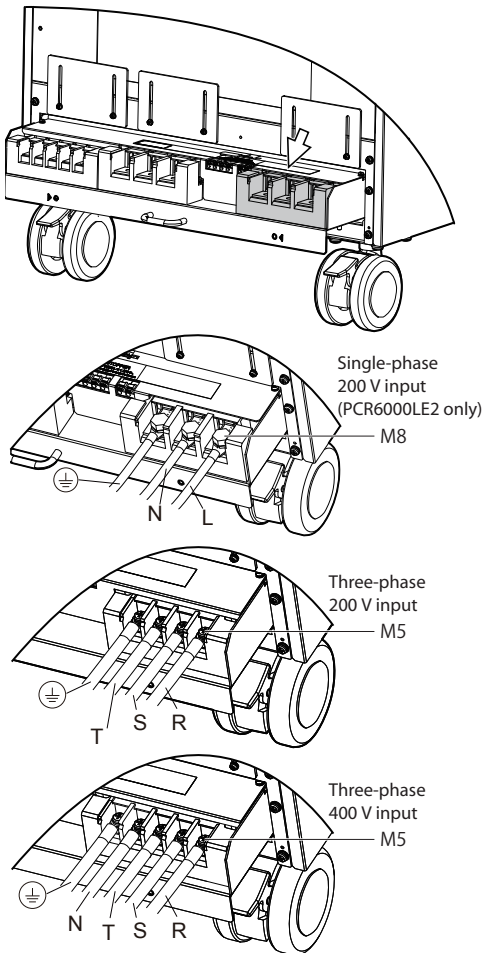

5 Turn off the switchboard's breaker.

6 Securely connect the power codes to corresponding terminals of switchboard's breaker.

7 Return the terminal block tray to its previous position.

If you do not insert the terminal block tray all the way into its storage compartment, an electric current will not flow through the PCR-LE2 Series even if the POWER switch is turned on.

8 Turn on the switchboard's breaker.

Connecting the power cord

Connecting power cords to the PCR1200LE2, PCR1800LE2, or PCR2700LE2

1 Check that the AC power line meets the nominal input rating of the product.

The product can receive a nominal power supply voltage:
Three-phase 200 V input: 200 Vac to 240 Vac (Line Voltage)
Three-phase, 400 V input: 220 Vac to 240 Vac (Phase Voltage)
Frequency: 50 Hz or 60 Hz.

2 Check that the POWER switch is turned off.

3 Unfasten the screws (two locations) of the AC INPUT terminal block cover, and remove the cover.

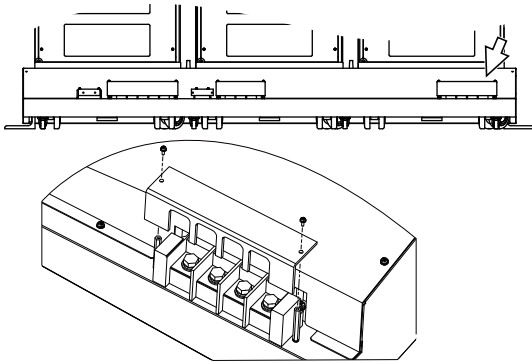

4 Connect the power cords according to the indications on the terminal block.

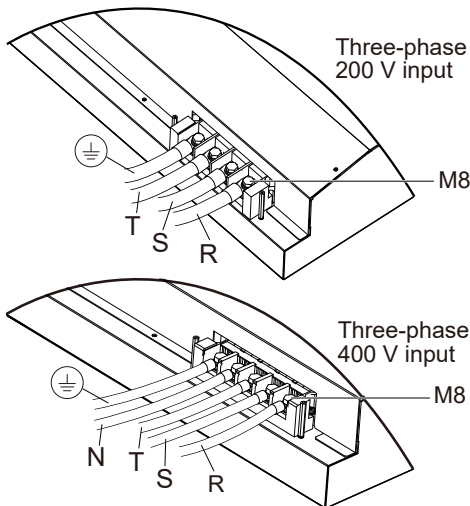

5 Turn off the switchboard's breaker.

6 Securely connect the power codes to corresponding terminals of switchboard's breaker.

7 Fasten the cover that you removed in step 3 with the screws (two locations).

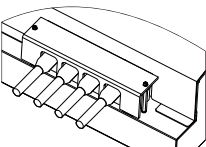

8 Turn on the switchboard's breaker.

Turning the Power On

Turning the POWER switch on

Turn the power on without the load connected.

If the POWER switch is turned on for the first time after purchasing the PCR-LE2 Series, the PCR-LE2 Series starts up using factory default settings. For all other cases, the PCR-LE2 starts up using the settings that were in use the last time that the POWER switch was turned off.

You can set the output on/off state at power on. For details, see "User's Manual -Basic-" on the accompanying CD-ROM.

If "ALARM" or an error number is displayed, see "Alarms and Trouble" on the accompanying CD-ROM.

■ Turning on the POWER switch on the PCR600LE2 or PCR900LE2.

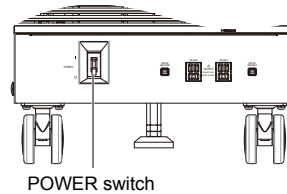

1 Check that nothing is connected to the OUTPUT terminal block on the rear panel and the outlets on the front panel.

2 Check that the power cord is connected correctly.

3 Flip the POWER switch to the (|) side to turn the PCR-LE2 Series on.

The firmware version is displayed for a few seconds. If no errors are detected, the home position (the basic screen) appears.

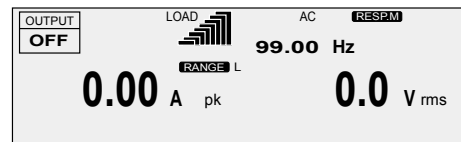

■ Turning on the POWER switch on the PCR12000LE2, PCR18000LE2, or 27000LE2

The PCR-LE2 series has a MASTER POWER switch and SLAVE POWER switches. You can turn off a SLAVE POWER switch to disconnect the product from the AC power line in an emergency. Normally, leave the SLAVE POWER switches turned on at all times, and use the MASTER POWER switch to turn on the product.

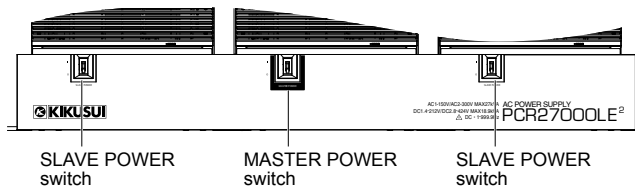

- 1 Check that nothing is connected to the OUTPUT terminal block on the rear panel and the outlets on the front panel.
- 2 Check that the power cord is connected correctly.
- 3 Check that the two SLAVE POWER switches are flipped to the (|) side.
If not, flip them to the (|) side.
- 4 Flip the MASTER POWER switch to the (|) side to turn the PCR-LE2 Series on.

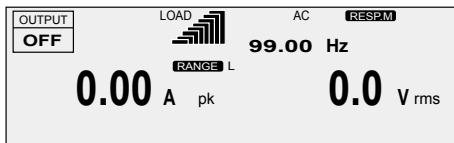

Turning the POWER switch off

- PCR6000LE2, PCR9000LE2
Flip the POWER switch to the (○) side to turn the PCR-LE2 Series off.
- PCR12000LE2, PCR18000LE2, PCR27000LE2
Flip the MASTER POWER switch to the (○) side to turn the PCR-LE2 Series off.

When the POWER switch is turned on, all items except for the following items take on the values that were in use the last time that the POWER switch was turned off.

- Waveform bank contents from number 24 to number 63
- Output on/off state

If the POWER switch is turned off immediately after the settings have been changed, the last settings may not be stored.

⚠ CAUTION

Risk of malfunction. After turning the POWER switch off, wait at least 5 seconds before turning it back on.

■ Turning off the POWER switch in an emergency

- PCR6000LE2, PCR9000LE2
Turning off the POWER switch disconnects the product from the AC power line.
- PCR12000LE2, PCR18000LE2, PCR27000LE2
Turning off the MASTER POWER switch and the two SLAVE POWER switches disconnects the product from the AC power line.

Provide enough space around the POWER switches to ensure that they can be turned off at any time.

Connecting the Load

The maximum current that the PCR-LE2 Series can generate varies depending on the model. It also varies depending on the PCR-LE2 Series' voltage mode, load type, and status. Ensure that the output power capacity is sufficient for the load capacity. The maximum output currents (in AC mode—AC rms, with an output voltage of 1 V to 100 V or 2 V to 200 V, and with a load power factor of 0.8 to 1) for the different models are shown in the table.

Model	Maximum output current			
	Single-phase output		Single-phase three-wire output Three-phase output	
	L range	H range	L range	H range
PCR6000LE2	60 A	30 A	20 A	10 A
PCR9000LE2	90 A	45 A	30 A	15 A
PCR12000LE2	120 A	60 A	40 A	20 A
PCR18000LE2	180 A	90 A	60 A	30 A
PCR27000LE2	270 A	135 A	90 A	45 A

- DESCRIPTION -

When the POWER switch is on, even if the output is off, a dangerous voltage exists between the output terminal (L/N or U/V/W/N) and the chassis (G-ground). To eliminate the voltage between the output terminal and the chassis, connect N and G of the OUTPUT terminal block.

■ Tightening torque of output terminal connecting screws

		Output terminal	Tightening torque [N·m]
PCR6000LE2	Single-phase output	M8	5.5
	Single-phase three-wire output	M5	2.0
	Three-phase output		
PCR9000LE2	Single-phase output	M8	5.5
	Single-phase three-wire output	M5	2.0
	Three-phase output		
PCR12000LE2		M8	5.5
PCR18000LE2			
PCR27000LE2			

Connecting to the OUTPUT terminal block

We recommend that you run the load wires alongside each other and tie them together at several points with cable ties. Connect between the output terminal and load with the shortest wires possible.

■ Preparing wires

Use noncombustible wires that have diameters that correspond to the output current to connect to the load.

Requirements of single-core wires that are used to connect to the load

Nominal cross-sectional area[mm ²]	AWG	(reference cross-sectional area; mm ²)	Allowable current* (A; at Ta = 30 °C, 86 °F)
0.9	18	(0.82)	17
1.25	16	(1.31)	19
2	14	(2.08)	27
3.5	12	(3.31)	37
5.5	10	(5.26)	49
8	8	(8.37)	61
14	6	(13.3)	88
22	4	(21.15)	115
38	1	(42.41)	162
60	2/0	(67.42)	217
80	3/0	(85.03)	257
100	4/0	(107.2)	298

* Excerpt from Japanese laws related to electrical equipment.

The values vary depending on conditions such as the wire covering (insulator), the wire material (allowable temperature), and whether there are multiple cores in the cable. For cables other than those specified in this table, consult with a qualified engineer.

WARNING

Risk of electric shock. Before you connect cables to the OUTPUT terminal block, be sure to turn the POWER switch off, and then turn off the switchboard.

- Note -

The L and N terminals of the OUTPUT terminal block are isolated from the input power supply. The polarity does not constitute a problem in terms of safety. The polarity matters in synchro mode (in which the product is synchronized with the input power supply) and DC mode, so check the polarity of the load before you connect it to the product. You can use either L or N to ground the product.

In DC mode and AC+DC mode, N is the reference. When N has a positive polarity, L is positive electric potential. When N has a negative polarity, L is negative electric potential.

Connecting cables to the PCR600LE2 or PCR9000LE2

■ Single-phase output

- 1 Check that the POWER switch is turned off.
- 2 Check that the breaker of the switchboard is off.
- 3 Pull out the terminal block tray.
- 4 **Securely connect the load cables to the OUTPUT 1P2W terminal block.**
If the load has a ground (GND) terminal, be sure to connect it to the G terminal of the PCR-LE2 Series OUTPUT 1P2W terminal block. Be sure to use a wire whose diameter is greater than or equal to the diameter of the wires used to connect the load.

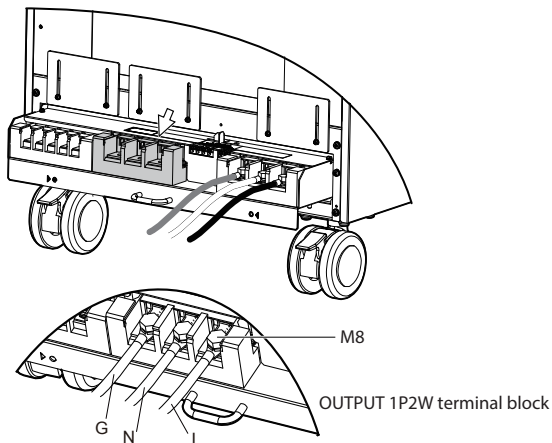

- 5 **Return the terminal block tray to its previous position.**
If you do not insert the terminal block tray all the way into its storage compartment, an electric current will not flow through the PCR-LE2 Series even if the POWER switch is turned on.

■ Single-phase three-wire output or three-phase output

- 1 Check that the POWER switch is turned off.
- 2 Check that the breaker of the switchboard is off.
- 3 Pull out the terminal block tray.
- 4 **Securely connect the load cables to the OUTPUT 3P4W(1P3W) terminal block.**
If the load has a ground (GND) terminal, be sure to connect it to the G terminal of the PCR-LE2 Series OUTPUT 3P4W(1P3W) terminal block. Be sure to use a wire whose diameter is greater than or equal to the diameter of the wires used to connect the load.

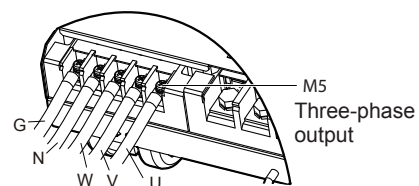
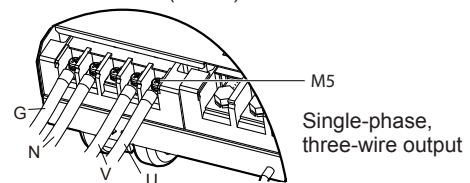
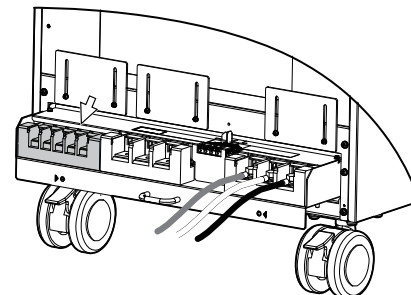

- 5 **Return the terminal block tray to its previous position.**
If you do not insert the terminal block tray all the way into its storage compartment, an electric current will not flow through the PCR-LE2 Series even if the POWER switch is turned on.

Connecting the Load (Cont.)

Connecting wires to the PCR1200LE2, PCR1800LE2, or PCR2700LE2

■ Handling the output terminal cover

When shipped from the factory, the terminal cover is attached using the left holes so that the OUTPUT terminals are not exposed.

If you are not using the OUTPUT terminal block, attach the terminal cover as figure below.

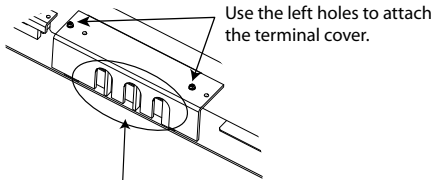

When the terminal cover is attached using the left holes, the output terminals are not exposed

When the load cable you use is 38 mm² (AWG1) or more, use the right holes to attach the terminal cover.

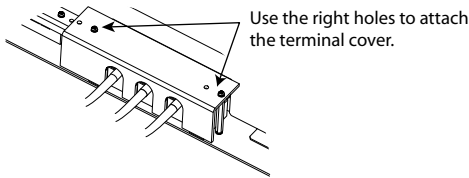

When the load cable you use is 60 mm² (AWG0/2) or less, flip the terminal cover upside down and attach it.

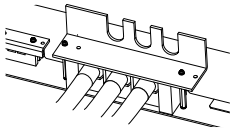

■ Single-phase output

- 1 Check that the **POWER** switch is turned off.
- 2 Check that the breaker of the switchboard is off.
- 3 Unfasten the screws (two locations) of the **OUTPUT 1P2W** terminal block cover, and remove the cover.

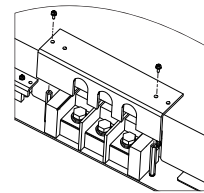
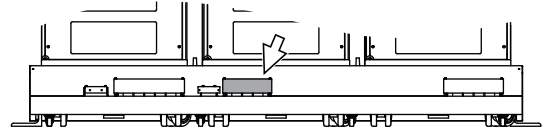

OUTPUT 1P2W terminal block

- 4 **Securely connect the load cables to the OUTPUT 1P2W terminal block.**

If the load has a ground (GND) terminal, be sure to connect it to the G terminal of the PCR2700LE2 OUTPUT 1P2W terminal block. Be sure to use a wire whose diameter is greater than or equal to the diameter of the wires used to connect the load.

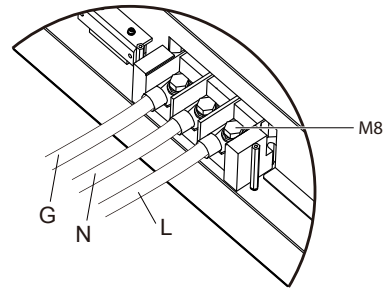

- 5 Fasten the cover that you removed in step 3 with the screws (two locations).

■ Single-phase three-wire output or three-phase output

1 Check that the POWER switch is turned off.

2 Check that the breaker of the switchboard is off.

3 Unfasten the screws (two locations) of the OUTPUT 3P4W(1P3W) terminal block cover, and remove the cover.

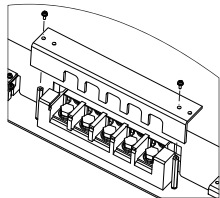
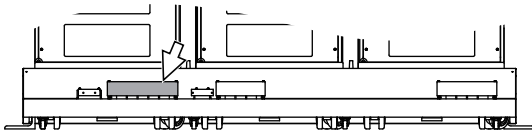

OUTPUT 3P4W(1P3W) terminal block

4 Securely connect the load cables to the OUTPUT 3P4W(1P3W) terminal block.

If the load has a ground (GND) terminal, be sure to connect it to the G terminal of the PCR27000LE2 OUTPUT 3P4W(1P3W) terminal block. Be sure to use a wire whose diameter is greater than or equal to the diameter of the wires used to connect the load.

Single-phase three-wire output

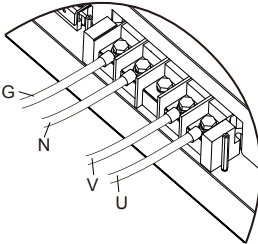

Three-phase output

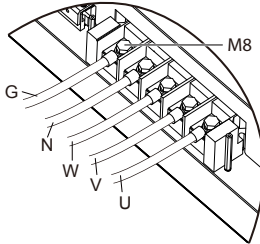

5 Fasten the cover that you removed in step 3 with the screws (two locations).

When the load is located at a remote location

Remote control can be used to turn the output off, but it cannot be used to turn the POWER switch off. If you want to connect the PCR-LE2 Series to a load that is located at a remote location, install a switch between the OUTPUT terminal block and the load to prevent electric shock. Then, turn that switch off.

⚠ WARNING

Risk of electric shock.

- Before you install the switch between the OUTPUT terminal block and the load, be sure to turn the POWER switch off and turn off the breaker of the switchboard.
- The current rating of the switch must be greater than or equal to the maximum current of the PCR-LE2 Series.
- For the switch circuit, use a multi-pole switch that can cut off all lines simultaneously (two poles for single-phase output, three poles for single-phase three-phase output, and four poles for three-phase output).
- Be sure to turn the switch off before connecting the load to the terminal at the load end of the switch.
- Do not touch the switch terminals when the POWER switch is on. Before you connect cables to the OUTPUT terminal block, be sure to turn the POWER switch off, and then turn off the switchboard.

Before you connect the cables, be sure to turn the POWER switch off and turn off the breaker of the switchboard.

OUTPUT terminal block

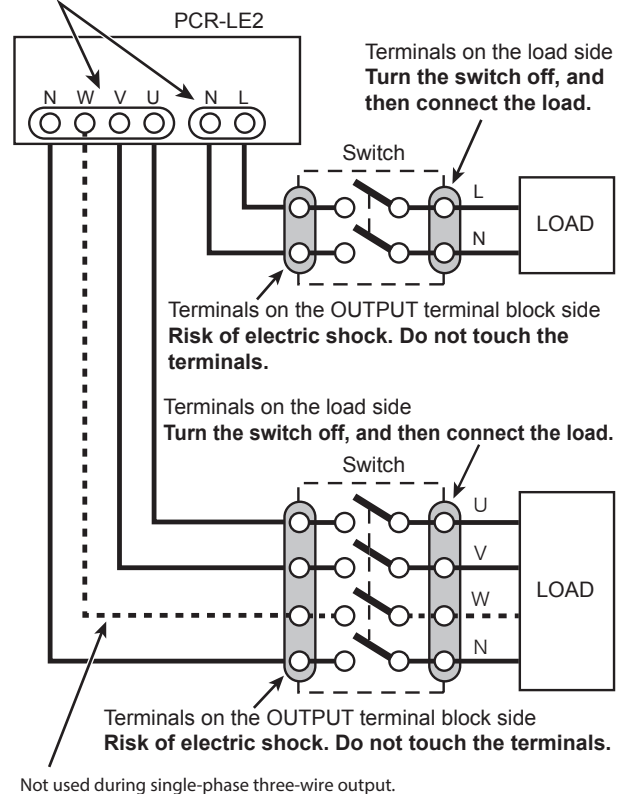

Connecting to the front-panel outlets (PCR6000LE2/ PCR9000LE2 only)

The PCR-LE2 Series can generate power from the OUTPUT terminal block on the rear panel and the outlets on the front panel.

The outlets on the front panel are valid for single-phase output. Electric current does not flow through the outlets during single-phase three-wire output or three-phase output.

The specifications of the front-panel outlets are not regulated. Their performance may decrease.

CAUTION

The maximum rated voltage of the front-panel outlets is 250 Vac.

Max. output voltage: 250 Vac(rms)

Maximum output current: 10 Aac (rms) per outlet

Do not disconnect the load when the maximum rated voltage of the outlets has been exceeded or in DC mode. Doing so may cause the product to malfunction.

On the PCR-LE2 Series, if an overcurrent is detected, the breaker trips, and the output is cut off.

The outlets are designed for power plugs like those shown below.

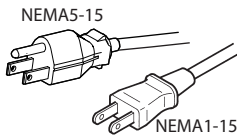

1 Turn the POWER switch off.

2 Connect the power cord of the load device to a front-panel outlet.



环境保护使用期限
Environment-friendly Use Period

该标记为适用于在中华人民共和国销售的电子信息产品的环境保护使用期限。

只要遵守有关该产品的安全及使用注意事项，从制造年月起计算，在该年度内，就不会对环境污染、人身、财产产生重大的影响。

产品的废弃请遵守有关规定。

产品的制造年月可以在以下网址中确认。

<http://www.kikusui.co.jp/pi/>

毒有害物质或元素名称及含有标示

Name of hazardous materials and symbol of element in the equipment and quantity

部件名称	有毒有害物质或元素					
	铅 Pb	汞 Hg	镉 Cd	六价铬 Cr(VI)	多溴联苯 PBB	多溴二苯醚 PBDE
印刷电路板组装品	×	○	○	○	○	○
显示器	×	○	○	○	○	○
内部接线	○	○	○	○	○	○
外壳	×	○	○	○	○	○
底盘组装品	×	○	○	○	○	○
辅助设备	○	○	○	○	○	○

本表格依据 SJ/T 11364 的规定编制。

○：该部件所有均质材料的有毒有害物质的含量不超过 GB/T 26572 标准所规定的极限值要求。

×：该部件至少有一种均质材料的有毒有害物质的含量超过 GB/T 26572 标准所规定的极限值要求。

The PCR-LE2 series is subject to export control laws.

■ Trademarks

All company names and product names used in the PCR-LE2 manual are trademarks or registered trademarks of their respective companies.

■ Copyrights

The contents of the PCR-LE2 manual may not be reproduced, in whole or in part, without the prior consent of the copyright holder.

The specifications of this product and the contents of this manual are subject to change without prior notice.