

Part No. Z1-002-522, IB003105
Sep. 2009

OPERATION MANUAL

PROGRAMMABLE DC POWER SUPPLY
PAX Series

PAX35-10
PAX35-20
PAX35-30

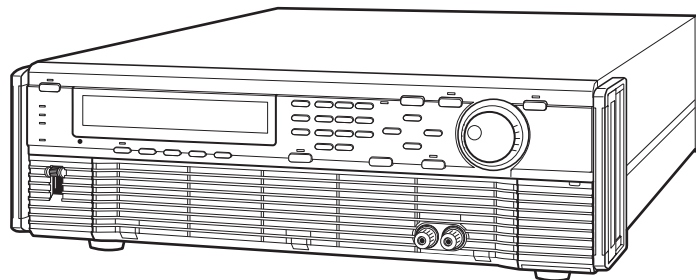

Use of Operation Manual

Please read through and understand this Operation Manual before operating the product. After reading, always keep the manual nearby so that you may refer to it as needed. When moving the product to another location, be sure to bring the manual as well.

If you find any incorrectly arranged or missing pages in this manual, they will be replaced. If the manual gets lost or soiled, a new copy can be provided for a fee. In either case, please contact Kikusui distributor/agent, and provide the “Kikusui Part No.” given on the cover.

This manual has been prepared with the utmost care; however, if you have any questions, or note any errors or omissions, please contact Kikusui distributor/agent.

Microsoft and Windows are registered trademarks of Microsoft Corp. in the United States and/or other countries.

All other company names and product names used in this document are trademarks or registered trademarks of the respective company.

Reproduction and reprinting of this operation manual, whole or partially, without our permission is prohibited.

Both unit specifications and manual contents are subject to change without notice.

Request to Users

This products must be used only by qualified personnel who understand the contents of this operation manual. If it is handled by disqualified personnels, electrical hazards may result. Be sure to handle it under supervision of qualified personnel (those who have electrical knowledge).

If any abnormality or failure was detected in the products, stop using it immediately and contact your Kikusui distributor or agent.

Installation

- Be sure the environmental condition where the products to be installed meets all requirements listed in the operation manual.
- To prevent electric shock, connect the ground terminal to electrical ground (safety ground).
- Connect the product to the specified AC power source with the AC power cable provided.
- For output wiring or load cables, use connection cables with larger current capacity.

Maintenance and inspection

- To prevent electric shock, be absolutely sure to unplug or stop applying power before performing maintenance or inspection.
- Make sure the AC input voltage setting and the fuse ratings are satisfied and that there is no abnormality in the AC power cable.
- Do not remove the cover when performing maintenance or inspection. There are parts inside the product which may cause physical hazards. Consult your Kikusui distributor or agent before uncover the products in case if it is so necessary.
- To maintain performance and safe operation of the product, it is recommend to conduct a periodic maintenance, inspection, cleaning, and calibration.

Relocation

- Disconnect all cables when relocate the product.
- Use two or more persons when relocate the product which weights more than 20 kg. The weight of the products can be found in this operation manual.
- Be careful of harming protruded parts of the products such as output terminals, terminal boards or heatsinks when moving.
- Use extra precautions such as using more people when relocating into or out of present locations including inclines or steps. Also handle carefully when relocating tall products as they can fall over easily.
- Be sure the operation manual are included whenever the product is moved, relocated or possession is passed to another party.

ROM Version Number

This manual is applicable to the power supplies which have the following version of ROM (read only memory).

2.0*

(* denotes 0 to 9.)

When making any inquires on your power supply, please indicate the following:

- Model No.
- ROM Version No.
- Serial No.

To find the ROM Version No., please refer to Section 2.3 "Power Turn-on Check" under Chapter 2 "PRECAUTIONS AND PREPARATIVE PROCEDURES." The Serial No. is indicated on the rear panel.

WARNINGS and **Caution**

Before start using the power supply and during using it, be sure to read and strictly observe the instructions given in the following:

"WARNINGS AND CAUTIONS" (next page)

Chapter 1 "GENERAL"

Chapter 2 "PRECAUTIONS AND PREPARATIVE PROCEDURES"

WARNINGS AND CAUTIONS

Although the power supply incorporates various protective features, you must handle it very carefully in order to prevent electric shock hazards to yourselves and to avoid damage to the equipment.

Strictly observe the **WARNINGS** and **Caution** given below.

WARNINGS

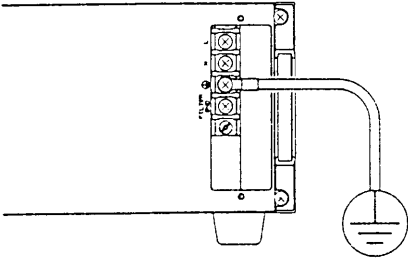

- Be sure to ground the power supply.
 - In order to prevent electric shock hazards, ground the ground terminal ⊕ of the power supply by using the GND wire (Green or Green/Yellow) of the AC input power cable.
 - If you neglect grounding the power supply or if the grounding line is made open, serious electric shock hazards may result.

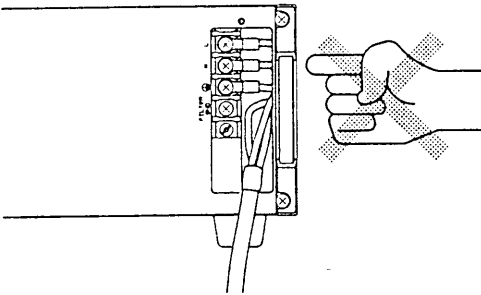

- Do not touch the input terminals.
 - The AC input power cable connection task involves danger. The task must be undertaken only by qualified personnel.
 - Before handling the AC input power cable or moving the power supply, be certain that the cable has been disconnected from the AC power source.

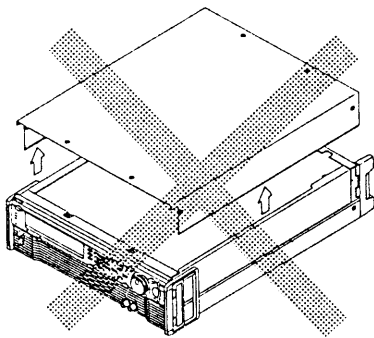

- Do not touch the internal components.
 - Do not touch the internal components of the power supply. Do not open the casing of the power supply.

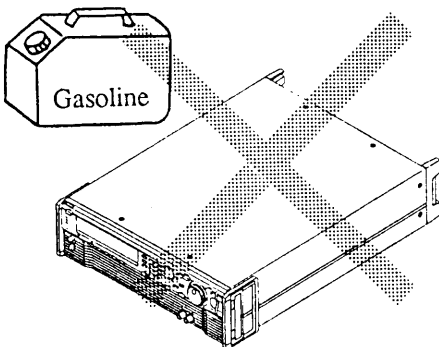

- Do not use the power supply in an explosive atmosphere.
 - Do not operate the power supply in a flammable, explosive, or otherwise hazardous area.

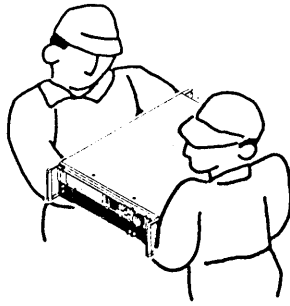

- Do not attempt to carry the power supply by yourself alone.
- The power supply is heavy (its weight is shown at a lower position on its rear panel). It must be carried by two or more persons.

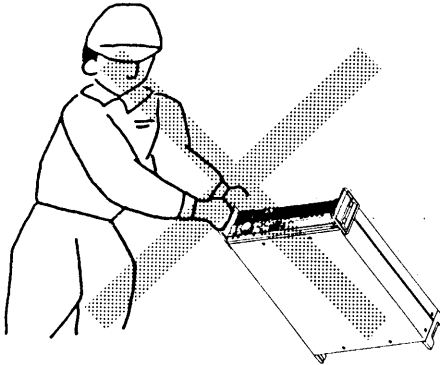

- Do not attempt to move the power supply by holding it by its only one of the handles.

Caution

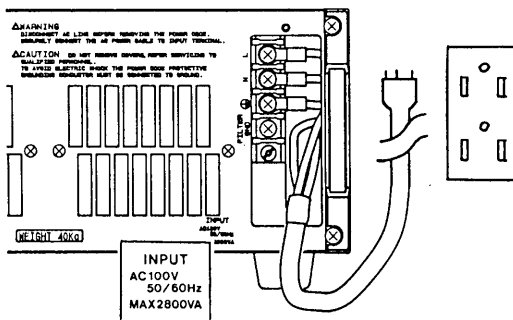

- Operate the power supply on a correct AC power source.
- Be certain that the AC input voltage and frequency are within the specified ranges. (The AC line requirements are shown near the input terminals.)
- Use the AC input power cable which is supplied accompanying the power supply. Do not use other cable.

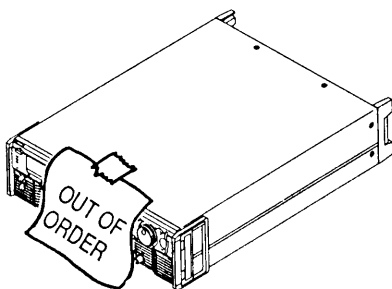

- Do not use a failed power supply.
- When the power supply has failed or has become malfunctioning, immediately stop using it and disconnect its AC input power cable from the AC power source--the AC line outlet or the AC power distribution panel.
- Indicate on the power supply clearly that it is out of order and must not be used.

Signs and Marks

The signs and marks put on the power supply are as follows.

WARNING

Sign for possible electric shock hazards

- This sign warns you that the place involves a danger--a matter of electric shock hazards to the personnel and damage to the equipment.
- When handling the matter related to the place, be sure to observe strictly the instructions given in the text of this manual.
- Unless you strictly observe the instructions, you will be exposing yourself to a danger of electric shock hazards.
- Until you fully understand the matters related to the WARNING, do not proceed to further steps of operation procedure.

CAUTION

Sign for possible damage

- This sign alert you to that the place involves a matter which can lead to damage to the power supply and/or the devices connected to it.
- When handling the matter related to the place, be sure to observe strictly the instructions given in the text of this manual.
- Unless you strictly observe the instructions, the power supply and/or the devices connected to it may be damaged.
- Until you fully understand the matters related to the CAUTION, do not proceed to further steps of operation procedure.

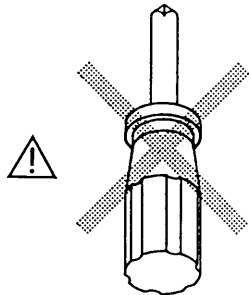

Mark for inhibition of disassembly or removal

- This mark appears on the AC input terminal cover.
- The mark means that the cover must not be removed by other persons than qualified electronics personnel.
- Before removing the cover, be certain that the AC input power cable has been disconnected from the power source--the AC line outlet or the power distribution panel.



Mark to refer to operation manual

- This mark requests you to refer to the corresponding section of the operation manual.



Earth ground



Chassis ground

Warnings, Cautions, and Notes

The warnings, cautions, and notes given in this operation manual deal with matters as follows:

WARNINGS

A matter which can lead to electric shock hazards.

Caution

A matter which can lead to damage to the power supply and/or the devices connected to it.

NOTE

Supplemental information.

RECEIVING INSPECTION

The power supply is shipped by the vendor upon full mechanical and electrical inspection and test to warrant that it meets the specifications. Upon receipt of the power supply, please immediately inspect it for damage which might have occurred during transportation. Also check that the accessories are present. If there are any signs of damage or missing accessories, please immediately notify the transportation company and/or your Kikusui agent as cases may call for.

The power supply (main unit) and its accessories delivered to you should be as follows:

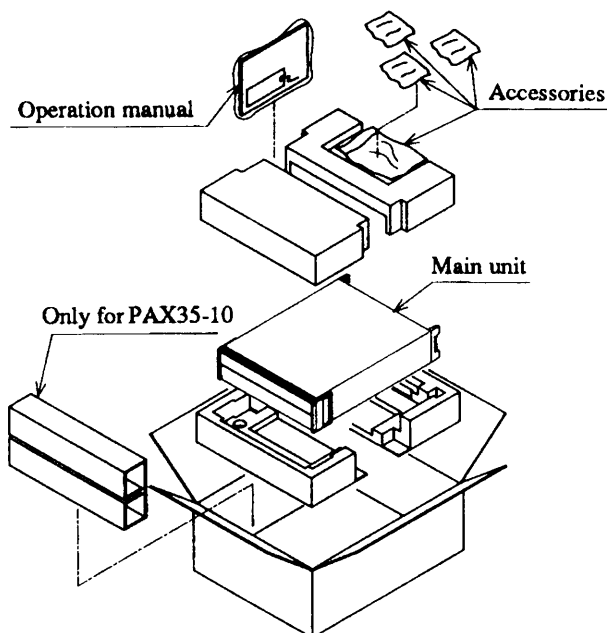

Accessories

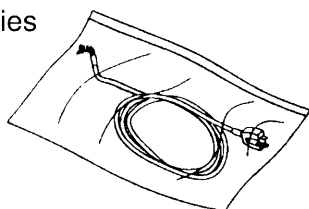

- AC input power cable (1)

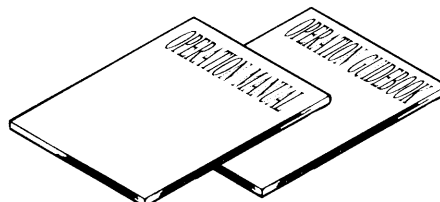

- Operation manual (1 copy)
- Sequence operation guidebook (1 copy)



- Terminals for analog remote control (20)

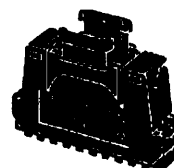

- Hood cover (1 set)

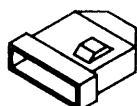

- Output terminal cover (1)
- Seals (2 sheets)

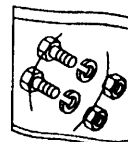

- Output terminal connection bolts (2)
- Nuts (2)
- Spring washers (2)

- The output terminal cover, bolts, nuts, and spring washers are for PAX35-30 only.

PACKAGING FOR RE-SHIPMENT

To re-ship the power supply, use the packaging materials in which the power supply was delivered to you. For packaging, refer to the illustration on the preceding page.

- When packaging the power supply, disconnect the AC input power cable, load cables, and control connectors.
- If you have discarded the packaging materials, please order your Kikusui agent for new ones.

COMPOSITION OF THE OPERATION MANUAL

This operation manual is composed of seven chapters and appendices as follows:

Chapter 1. GENERAL

Introduces an outline and features of the power supply.

Chapter 2. PRECAUTIONS AND PREPARATIVE PROCEDURES

Elaborates procedures for installation, AC input power cable connection, power-on test, operating mode selection, and load connection.

Chapter 3. OPERATING METHOD

The former half of this chapter introduces the names and functions of keys, indicators and other panel items, and the basic operating method of the power supply; the latter half describes the procedures for sequence operation and applied types of operation.

Chapter 4. REMOTE PROGRAMMING

Elaborates the method to remote-control the power supply via an interface board (optional) from an external device.

Chapter 5. PANEL DESCRIPTION

Introduces the names of and describes the functions of the switches and other items of the front and rear panels.

Chapter 6. MAINTENANCE AND CALIBRATION

Elaborates the maintenance, inspection, and calibration methods.

Chapter 7. SPECIFICATIONS

Gives tables of electrical specifications, mechanical specifications, accessories, and optional items.

APPENDICES

Provides an error message table, a troubleshooting chart, a table of factory-defaults, a menu configuration chart, sequence coding sheets, and a table of ID codes and offset calibration values.

	PAGE
WARNINGS AND CAUTIONS	II
RECEIVING INSPECTION	VI
PACKAGING FOR RE-SHIPMENT	VII
COMPOSITION OF THE OPERATION MANUAL	VIII
Chapter 1. GENERAL	1-1
1.1 Outline	1-2
1.2 Features	1-3
Chapter 2. PRECAUTIONS AND PREPARATIVE PROCEDURE	2-1
2.1 Installation	2-2
2.1.1 Environments	2-2
2.1.2 Precautions for Moving the Power Supply	2-4
2.2 Connecting the AC Input Power Cable	2-5
2.3 Power-on Test	2-8
2.4 Operating Mode Selection	2-10
2.5 Load Connection Procedure	2-12
2.5.1 Notes for Particular Types of Loads	2-13
2.5.2 Notes for Load Connection	2-14
Chapter 3. OPERATING METHOD	3-1
3.1 Description of Front and Rear Panels	3-3
3.1.1 Front Panel	3-3
3.1.2 Rear Panel	3-3
3.2 Basic Operating Method 1	3-5
3.2.1 Turning ON/OFF the POWER Switch	3-5
3.2.2 Basic Panel Operating Method	3-6
3.2.3 Voltage/Current Settings and Output ON/OFF	3-10
3.2.4 Fine Setting of Output Voltage or Current	3-13
3.2.5 Setting of Protective Actions	3-14
3.2.6 To Reset from Protective Alarm Status	3-18
3.3 Basic Operating Method 2	3-20
3.3.1 Remote Sensing Function	3-20
3.3.2 Memory Function	3-21
3.3.3 Setup Function	3-23
3.3.4 Keylock Function	3-29
3.3.5 Setting the Click Resolution	3-30
3.3.6 Setting the Rise/Fall Time	3-31
3.3.7 Displaying the Interface Status	3-32
3.4 Sequence Operation	3-33
3.4.1 Description of Sequence Operation	3-33
3.4.2 Outline of Settings for Operation	3-39
3.4.3 Procedures for Sequence Operation	3-40
3.5 Applied Types of Operation	3-54
3.5.1 Configuration	3-54
3.5.2 Analog Remote Control	3-65

Chapter 4. REMOTE PROGRAMMING	4-1
4.1 Initial Setting of Interface	4-3
4.1.1 GPIB Interface	4-3
4.1.2 RS-232C Interface	4-4
4.1.3 MCB Interface	4-5
4.2 Programming Format	4-6
4.2.1 Commands	4-6
4.2.2 Response Message	4-7
4.2.3 Acknowledge Message (RS-232C)	4-7
4.2.4 Flow Control (RS-232C)	4-8
4.3 Description of Commands	4-9
4.3.1 Terminology	4-9
4.3.2 Structures of Commands	4-10
4.4 Bit Assignment of Registers	4-25
4.5 Relationships Among SRQ, Status Bytes, and Registers	4-28
4.6 Table of Error Codes	4-29
4.7 Examples of Remote Programming	4-30
4.7.1 Initializing the Interface Board	4-30
4.7.2 Examples of Application Programs	4-31
4.7.3 Table of Command Headers	4-45
Chapter 5. PANEL DESCRIPTION	5-1
5.1 Front Panel	5-2
5.2 Rear Panel	5-6
Chapter 6. MAINTENANCE AND CALIBRATION	6-1
6.1 Maintenance and Inspection	6-2
6.2 Calibration	6-4
6.2.1 Preparation	6-4
6.2.2 Calibration Instruments	6-4
6.2.3 Calibration Setups	6-4
6.2.4 Calibration Procedures	6-5
Chapter 7. SPECIFICATIONS	7-1
7.1 Electrical Specifications	7-2
7.2 Dimensions and Weights	7-11
7.3 Accessories	7-12
7.4 Optional Items	7-13
APPENDICES	A-1
Appendix 1. Table of Error Messages	A-2
Appendix 2. Troubleshooting Chart	A-5
Appendix 3. Table of Factory-Defaults	A-7
Appendix 4. Menu Charts	A-8
Appendix 5. Sequence Coding Sheets	A-13
Appendix 6. Table of ID Codes and Offset Calibration Values	A-16
INDEX	I-1

Chapter 1

GENERAL

This chapter introduces an outline and features of the Programmable DC Power Supplies, PAX Series.

Contents	Page
1.1 Outline	1-2
1.2 Features	1-3

1.1 Outline

The PAX Series Programmable DC Power Supplies are regulated DC power supplies featured by performance reliability and safety. They employ a power amplifier system, thereby rendering advantageous features such as low ripple noise, high stability, and rapid response. They are microprocessor-based instruments and provide advanced functions and ease of operation.

They can be remote-controlled via a GPIB, RS-232C, or MCB (Multi-channel Bus) interface (optional), thereby making them applicable to various purposes. Typical applications are for research systems in laboratories and on production and inspection lines in manufacturing plants.

1.2 Features

Each PAX Power Supply is incorporated or can be optionally incorporated with the various advantageous features as follows:

(1) Two operating modes

The power supply allows you to select one of the following two types of operating modes.

- (a) Fast mode: For rapid rise up and fall down (Selectable for $50\mu\text{s}$, $500\mu\text{s}$ or 5ms)
- (b) Normal mode: For stable operation with low ripple noise (Since no switching actions are involved, the output noise is small.)

(2) Sequence control of output

You can enter sequence control patterns from the local panel or from a personal computer via GPIB or other interface bus and store them as sequence files on the internal memory. The stored files can be recalled locally from the front panel or remotely from the host controller via the interface bus.

Control sequences can be programmed in either one of the following two types:

- (a) Fast speed sequence: You can program sequences with minimum $100\mu\text{s}$ per step.
- (b) Normal speed sequence: You can program sequences with a ramp waveform per step.

(3) Various interface boards (optional)

The power supply can be controlled over a GPIB, RS-232C, or MCB interface bus. This feature, as combined with the programmed sequence control function, allows you a high flexibility of power supply system configuration.

The MCB is a unique interface developed by Kikusui. It allows you to control up-to-fifteen instruments (power supplies and electronic load devices) in an on-line mode over a standard interface system (GPIB or RS-232C).

(4) Ease of operation

Numeric entry keypad, arrow keys, and JOG/SHUTTLE dials are provided on the front panel, to facilitate entry of numerical values and selection of menu items.

Operation SETUPS of the power supply can be stored in memory and be recalled whenever you need them. Up to four different types of voltage/current settings can be programmed and stored in different locations of memory. This feature is convenient especially when you want to repeat tests with the same setup of the power supply.

(5) A large backlight LCD

The power supply has a large backlit-type LCD (liquid crystal display), which displays output voltage and current settings, readbacks, and other operation data.

(6) Ease of calibration

The power supply can be calibrated easily with the keys on the front panel, without requiring any sophisticated calibration procedures (but requiring a digital voltmeter and a shunt resistor).

(7) Various protective provisions

The power supply incorporates provisions for double-protection with software protectors and hardware protectors against output overvoltage (OVP) and overcurrent (OCP). The software protectors provide an automatic function that the power supply automatically sets the limit values as you specify a tolerance of overvoltage or overcurrent in percentage. They also allow you to select either "POWER switch OFF" or "OUTPUT OFF" for protection when a protector has tripped and the power supply has fallen into an alarm state.

The power supply also incorporates an overtemperature protector and an input overcurrent protector. Thus, the various provisions are incorporated to protect the power supply itself and its load.

(8) Analog remote control

You can remote-control the output voltage or current with an external voltage signal or resistance. You also can remote-control turning OFF of the POWER switch and turning ON/OFF of the output. The power supply provides various status signals.

(9) Exclusive remote controller (optional)

The remote controller allows you to extend virtually the front panel to a remote position convenient for you. The control functions of the remote controller are identical with those of the front panel of the power supply.

Chapter 2

PRECAUTIONS AND PREPARATIVE PROCEDURES

This chapter gives you information on precautions you must observe and preparative procedures you must follow before start operating the power supply.

Contents	Page
2.1 Installation	2-2
2.1.1 Environments	2-2
2.1.2 Precautions for Moving the Power Supply	2-4
2.2 Connecting the AC Input Power Cable	2-5
2.3 Power-on Test	2-8
2.4 Operating Mode Selection	2-10
2.5 Load Connection Procedure	2-12
2.5.1 Notes for Particular Types of Loads	2-13
2.5.2 Notes for Load Connection	2-14

2.1 Installation

2.1.1 Environments

Avoid using the power supply in adverse or hazardous environments as mentioned below.

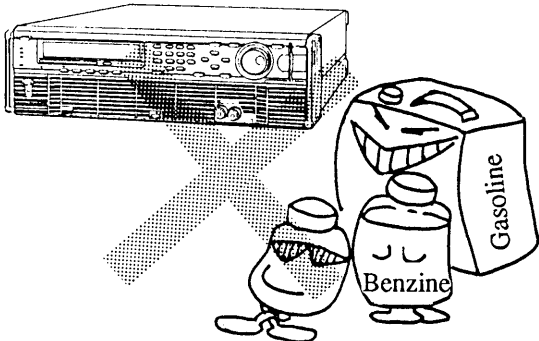

(a) Flammable atmosphere

Do not use the power supply in flammable or explosive atmosphere, to prevent fire and explosion hazards.

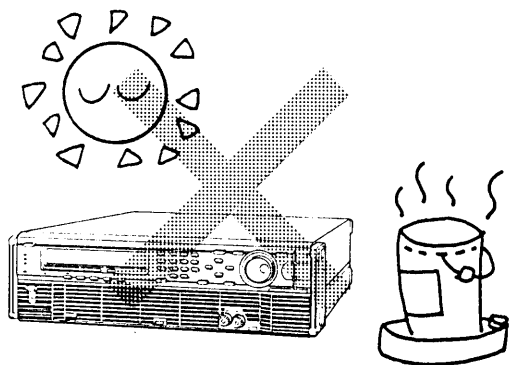

(b) High temperature

Do not expose the power supply to a source of heat, such as direct sunlight (near a window), a space heater, etc. Avoid a place where temperature may change rapidly.

(The temperature range for the guaranteed performance is 0 to 40°C or 32 to 104°F.)

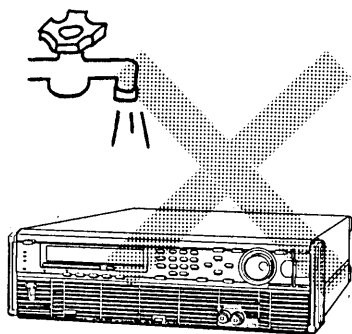

(c) High humidity

Do not expose the power supply to high humidity--do not place it near a water heater, a humidifier, a water faucet, or a bath.

(The humidity range for the guaranteed performance is 30 to 80% RH.)

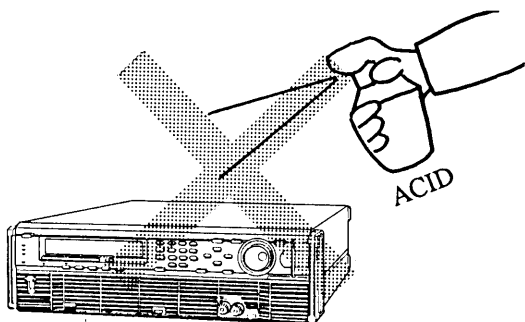

(d) Corrosive atmosphere

Do not expose the power supply to corrosive atmosphere--such as of sulfuric acid mist.

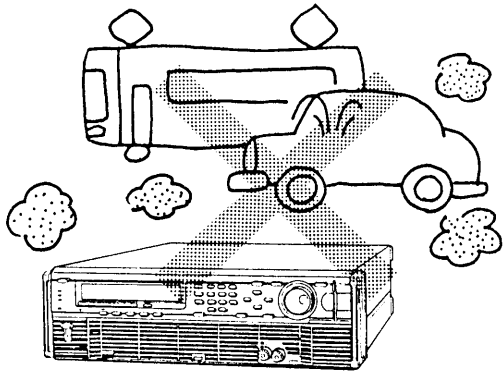

(e) Dusty place

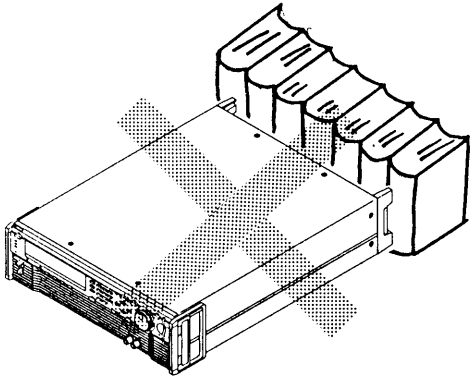

(f) Blocked ventilation air flow

Do not block the louvers of the power supply.

Provide an ample space (30 cm or more) behind the rear panel of the power supply.

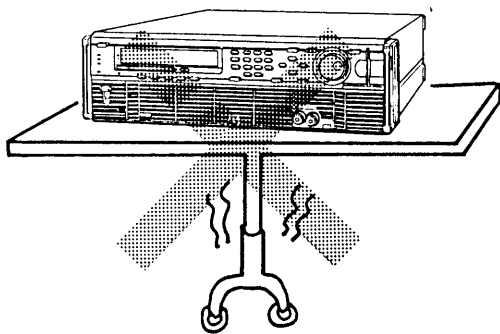

(g) Unstable position

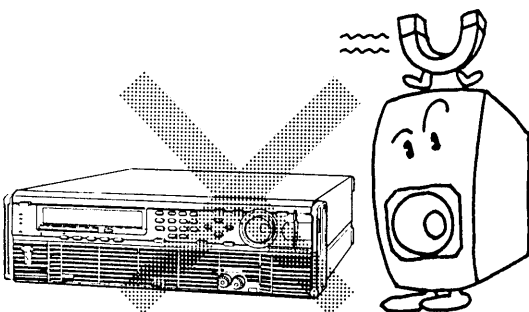

(h) Strong electric or magnetic field

2.1.2 Precautions for Moving the Power Supply

WARNINGS

- *Be sure to disconnect the AC input power cable from its power source before moving the power supply.*
- *The power supply is heavy (its weight is shown at a lower position on its rear panel). Do not attempt to carry it by yourself alone--it must be carried by two or more persons.*

Caution

- *Do not attempt to move the power supply by holding it by its only one of the handles. (For how to use the handles, see the description which follows.)*

How to Use the Handles

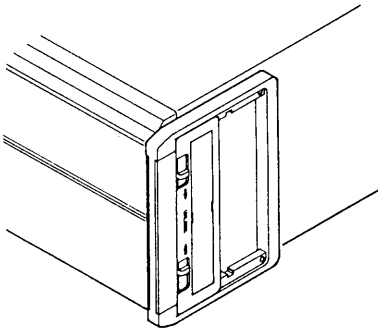

- ① Slide the two lock switches simultaneously in the "UN-LOCK" direction, and the handles will become movable.

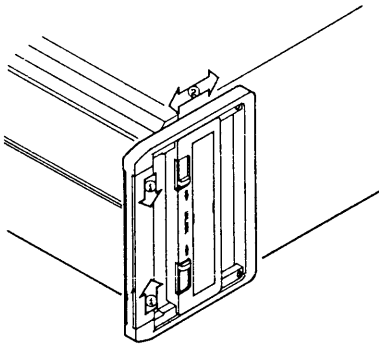

- ② Fully pull-out or push-in the handles until they click.

2.2 Connecting the AC Input Power Cable

WARNINGS

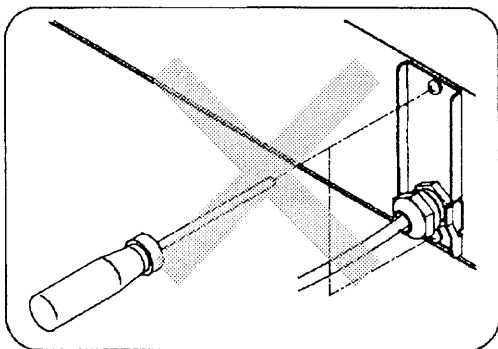

- (a) The AC input power cable connection task involves danger. The task must be undertaken only by qualified personnel.
- (b) Before handling the AC input power cable, make certain that the cable has been disconnected from the AC power source.
- (c) Be sure to ground the power supply.
 - In order to avoid electric shock hazards, be sure to connect the GND (⏚) terminal of the power supply to an earth ground by using the GND wire (Green or Green/Yellow wire) of the AC input power cable.
 - Note that, unless the GND terminal is securely connected to an earth ground, serious electric shock hazards can result.
- (d) Be sure to put back the input terminal cover.
 - Guard against inadvertently touching the input terminals. Do not neglect installing the terminal cover when operating the power supply.

Caution

- Use the AC input power cable which is supplied accompanying the power supply. When it is unavoidable to use other cable, use a one which has sufficient voltage and current ratings and is nonflammable and has been determined to be appropriate by a qualified engineer.
- Make certain that the AC source voltage and frequency are within the specified ranges.

AC Input Power Cable Connection Procedure

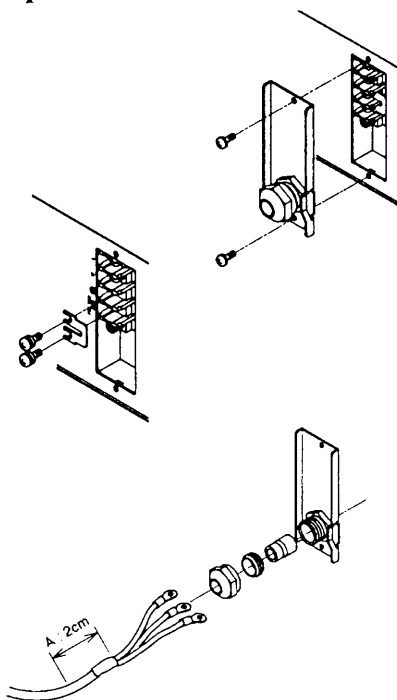

- ① Remove the AC input terminal cover at a right hand position on the rear panel.
- ② If the leak current is not permissible, disconnect the short piece from between the GND (⏚) terminal and the FILTER GND terminal. If the leak current is permissible, proceed to Step ③.
 - For the leak current, see the subsequent page.
- ③ Pass the AC input power cable through the input terminal cover.
 - To pass the cable more easily, you may disassemble the cable clamp as illustrated.
 - Clamp the cable by its sheath end (A).

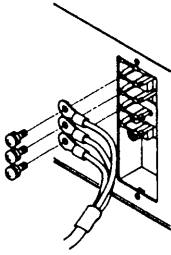

- ④ Connect the cable to the input terminals.
- The core wires of the cable are color coded as shown below. Be sure to connect the correct wires to the correct terminals.

L (live): Black or Brown

N (neutral): White or Blue

GND (⊕): Green or Green/Yellow

A section of screw on this terminal board is 4 mm (M4).

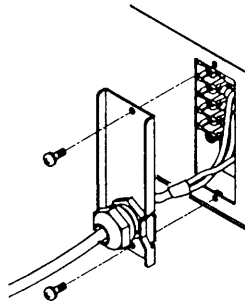

- ⑤ Put back the terminal cover.

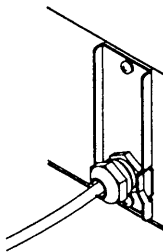

- ⑥ Securely tighten the cable clamp.

- Make certain that the cable is securely clamped and is not loose.

Connecting the power supply to a switchboard

Depending on model or input voltage of the power supply, the supplied AC input power cable may not be equipped with a plug. To connect the AC input power cable, put crimping terminals which are suited to the terminals of the switchboard on AC input power cable.

Work to connect the power supply to the switchboard must be performed by qualified personnel.

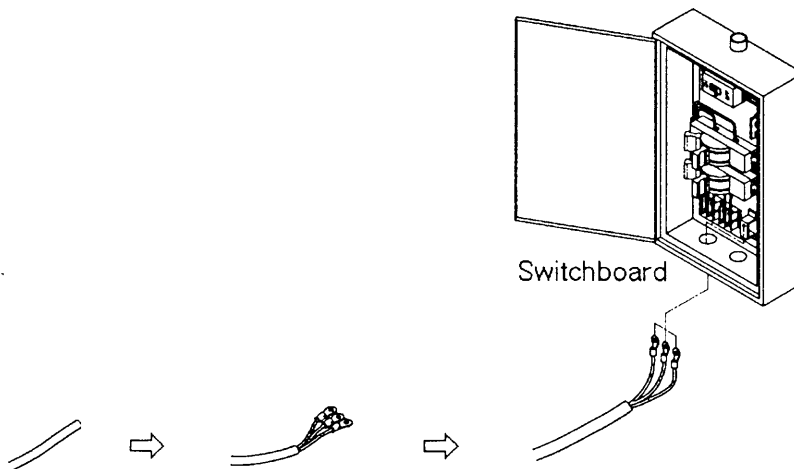

Check terminal polarity of the switchboard, and connect the AC input power cable surely.

L (live): Black or Brown

N (neutral): White or Blue

GND (⊕): Green or Green/Yellow

Leak Current

A noise filter is provided in the input circuit of the power supply, in order to reduce the common-mode noise which could be generated between the AC line and the chassis. The noise filter has capacitors connected between the L (live) line and the N (neutral) line. A leak current flows through these capacitors.

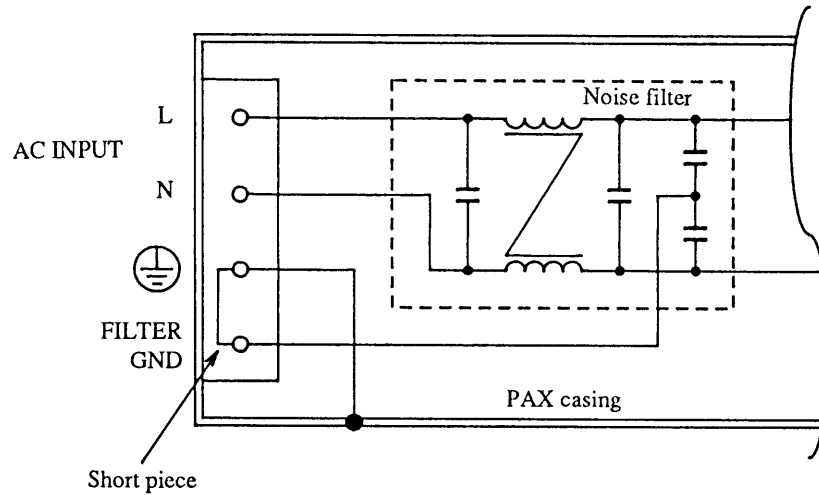

When a multiple number of power supply units are operated together (typically, being installed on a rack) and the leak current is intolerably large, execute the procedure of Step ② and provide other noise filter on the AC input side as illustrated.

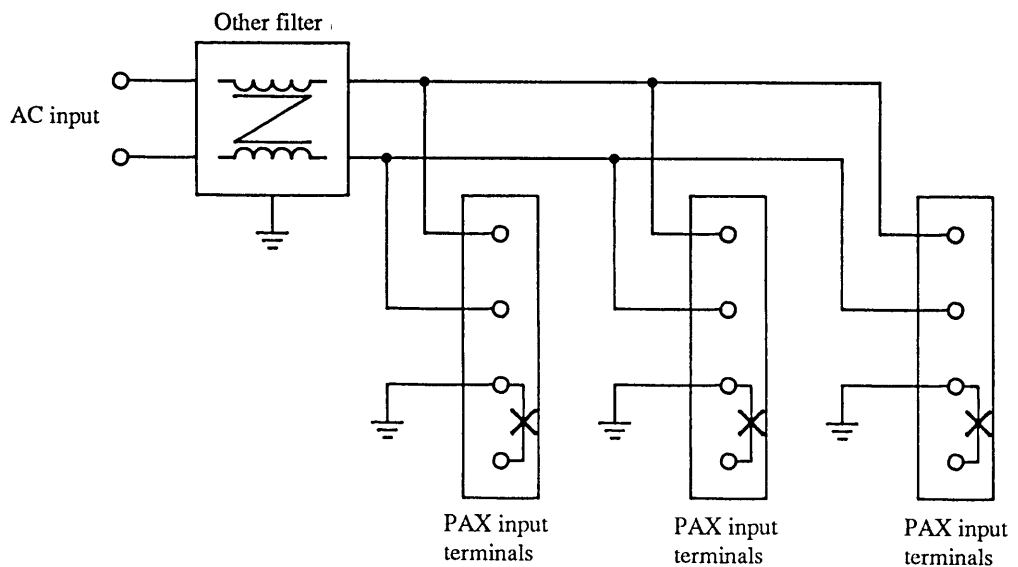

2.3 Power-on Test

Perform power-on test of the power supply as follows:

Power-on Test Procedure

① Make certain that the POWER switch is OFF.



② Make certain that the instrument-side end of the AC input power cable is connected to the power supply.

WARNINGS

• *If the cable is not connected yet, connect it observing the instructions given in "WARNINGS AND CAUTIONS," Chapter 1 "GENERAL," and Chapter 2 "PRECAUTIONS AND PREPARATIVE PROCEDURES"*



③ Connect the power-source-side end of the AC input power cable to an AC line receptacle or power distribution panel.



Caution

• *Make certain that the AC line voltage and frequency are within the specified ranges.*

④ Turn-on the POWER switch of the power supply.

Normal indications:

If the power supply is normal, a sign-on display (Model No. and ROM Version No.) will appear for about 2 seconds and then a root display will appear as shown below.

(An example of sign-on display)

```
PAX 35-10   Ver1.00
NONE       KIKUSUI
```



(An example of root display)

```
OUT   0.000V   0.00A
```

Abnormal Indications:

If the power supply is abnormal, one of the below-mentioned displays will appear. If this is the case, follow the instruction indicated by ☞. If the abnormal state is not remedied still, order your Kikusui agent for repair.

- The display screen backlight does not illuminate and nothing is displayed on the screen.

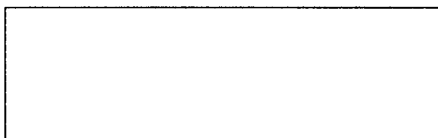

☞ Make certain that the AC input power cable is connected correctly. Then turn-on the POWER switch again.

- Although the display screen backlight illuminates, nothing is displayed on the screen.

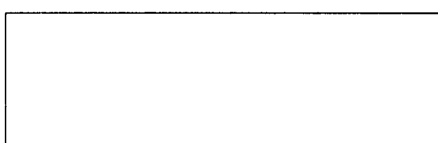

☞ Adjust the CONTRAST control (varies depending on temperature). Then turn-on the POWER switch again.

- Although a cursor is displayed, no characters are displayed.

Cursor

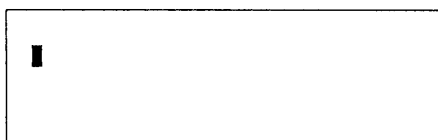

☞ If the interface board (optional) has been installed, remove it and then turn-on the POWER switch again. If the display is remedied by this procedure, install the interface board and then turn-on the POWER switch.

- The output voltage or current value indicated on the root display is abnormal.

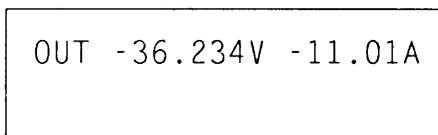

(This is an example.)

☞ Turn-on the POWER switch again.

- An error message appears.

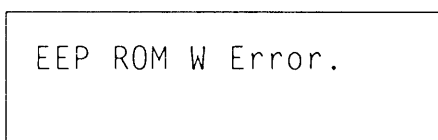

(This is an example.)

☞ Refer to Appendix 1 "Table of Error Messages" and take the actions as required.

Then turn-on the POWER switch again.



⑤ Turn-off the POWER switch.

The power-on test procedure is complete by the above.

2.4 Operating Mode Selection

The power supply can operate in either one of the below-mentioned two modes of operation. Select one of them.

Fast mode

This mode is for rapid rise up and fall down ($50\mu\text{s}$, $500\mu\text{s}$ or 5ms) of the output.

Caution

- *If you select the Fast mode when supplying a constant current to an inductive load, the setup may oscillate due to phase rotation. To prevent this, compensate for the phase rotation by connecting in parallel to the load a circuit consisting of a capacitor and a resistor connected in series. If the setup oscillates still, select the Normal mode.*
- *If a capacitor whose high-frequency impedance is small is connected directly to the output terminal when the power supply is operating in the Fast mode, the setup may oscillate depending on conditions of the load.*

Normal mode

This mode is for the regular operating mode of the power supply such that the internal electrolytic capacitor of the power supply is connected in parallel to the output terminals of the power supply and consequently, when it is in the CV mode, it operates with less noise and delivers a highly stable output.

Mode selection procedure

Caution

- Before changing between the Fast mode and the Normal mode, be certain that the POWER switch has been turned off.

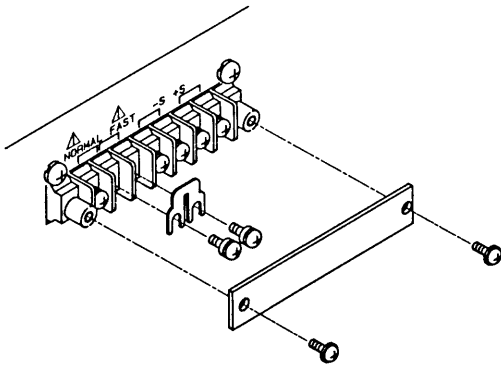

- ① Remove the cover of the mode select terminal block on the rear panel.
- ② Connect the mode select short piece to the terminals corresponding to the mode you want to select.
- ③ Put back the cover.

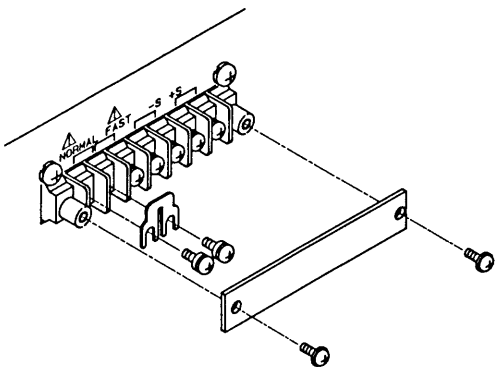

Caution

- Be sure to put back the cover of the mode select terminal block.

2.5 Load Connection Procedure

The load connection procedures differ by models.

Load connection for PAX35-10, and PAX35-20

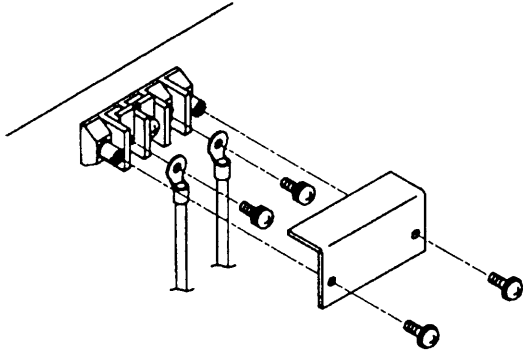

- ① Remove the rear output terminal cover. Connect the load-connection cables to the output terminals of the power supply.
- ② Put back the cover.

Load connection for PAX35-30

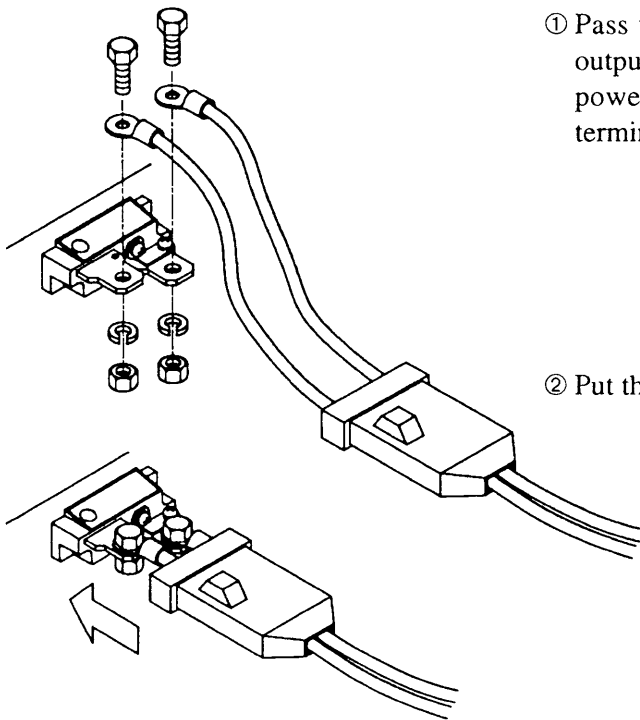

- ① Pass the load-connection cables through the hole of the output terminal cover which is supplied accompanying the power supply and then connect the cables to the output terminals.
- ② Put the terminal cover onto the output terminals.

Caution

- Be sure to connect the correct cables to the correct output terminals.
- Securely tighten the terminal bolts.
- Be sure to use the bolts supplied being already driven into the terminals or supplied accompanying the power supply. Do not use other bolts.
- Be sure to put back the terminal cover onto the output terminals.

2.5.1 Notes for Particular Types of Loads

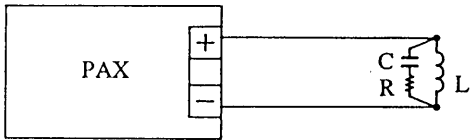

○ If you select the Fast mode when supplying a constant current to an inductive load, the setup may oscillate due to phase rotation. To prevent this, compensate for the phase rotation by connecting in parallel to the load a circuit consisting of a capacitor and a resistor connected in series. If the setup oscillates still, select the Normal mode. (Refer to Chapter 2.4 "Operating Mode Selection.")

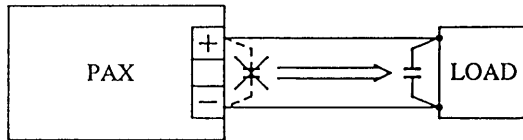

○ If a capacitor whose high-frequency impedance is small is connected directly to the output terminal when the power supply is operating in the Fast mode, the setup may oscillate depending on conditions of the load.

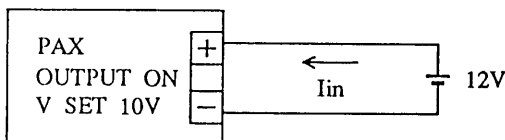

○ If the load is regenerative and its output voltage is higher than the power supply output voltage, the power supply output circuit will draw from the load a current of up to 20% of the rated output current of the power supply. When the output circuit is set to OFF, however, it draws almost no substantial current because it is in a high impedance state.

Caution

• Pay attention so that no voltage higher than the rated output voltage of the power supply is applied to its output circuit.

○ When a current with peaks is drawn from the power supply operating in the constant-voltage mode, the CC LED may not illuminate even when peaks exceed the current setting and the power supply is driven into the CC mode for very short periods. When this state has occurred, the output voltage will drop. (The same applies also when a voltage with peaks is to be delivered from the power supply operating in the constant-current mode.)

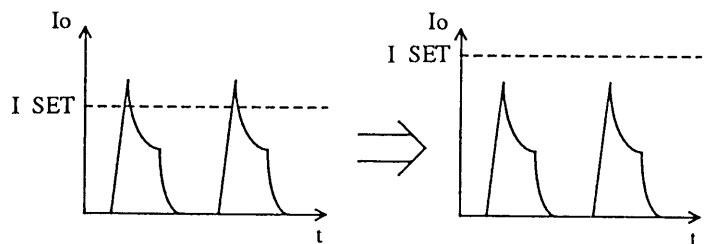

2.5.2 Notes for Load Connection

When connecting a load to the power supply, note the following:

- Use large cables. Make the cable distances as short as possible.
- Strand the "+" and "-" cables.
- Pay attention so that no loops are formed.
- Wire gauges (nominal cross section areas) recommended by Kikusui are as follows:
 - Up to 10A 2 mm²
 - Up to 20A 5.5 mm²
 - Up to 30A 8 mm²
 - Up to 50A 14 mm²
 - Up to 60A 22 mm²
 - Up to 100A 38 mm²
 - Up to 200A 80 mm²

Chapter 3

OPERATING METHOD

The former half of this chapter introduces the names and functions of keys, indicators and other panel items, and the basic operating methods of the power supply; the latter half describes procedures for sequence operation and applied types of operation.

Contents	Page
3.1 Description of Front and Rear Panels	3-3
3.1.1 Front Panel	3-3
3.1.2 Rear Panel	3-3
3.2 Basic Operating Method 1	3-5
3.2.1 Turning ON/OFF the POWER Switch	3-5
3.2.2 Basic Panel Operating Method	3-6
3.2.3 Voltage/Current Settings and Output ON/OFF	3-10
3.2.4 Fine Setting of Output Voltage or Current	3-13
3.2.5 Setting of Protective Actions	3-14
3.2.6 To Reset from Protective Alarm Status	3-18
3.3 Basic Operating Method 2	3-20
3.3.1 Remote Sensing Function	3-20
3.3.2 Memory Function	3-21
3.3.3 Setup Function	3-23
3.3.4 Keylock Function	3-29
3.3.5 Setting the Click Resolution	3-30
3.3.6 Setting the Rise/Fall Time	3-31
3.3.7 Displaying the Interface Status	3-32
3.4 Sequence Operation	3-33
3.4.1 Description of Sequence Operation	3-33
3.4.2 Outline of Settings for Operation	3-39
3.4.3 Procedures for Sequence Operation	3-40
3.5 Applied Types of Operation	3-54
3.5.1 Configuration	3-54
3.5.2 Analog Remote Control	3-65

MEMO

3.1 Descriptions of Front and Rear Panels

3.1.1 Front Panel

Refer to chapter 5. "5.1 Front Panel".

3.1.2 Rear Panel

Refer to chapter 5. "5.2 Rear Panel".

MEMO

3.2 Basic Operating Method 1

This section describes the basic panel operating method and messages displayed, the basic voltage/current setting method, and the protective functions of the power supply.

3.2.1 Turning ON/OFF the POWER Switch

The top position of the POWER switch is for ON and the bottom position for OFF. As you turn ON the POWER switch, a sign-on display will appear and, after about 2 seconds, a root display will appear.

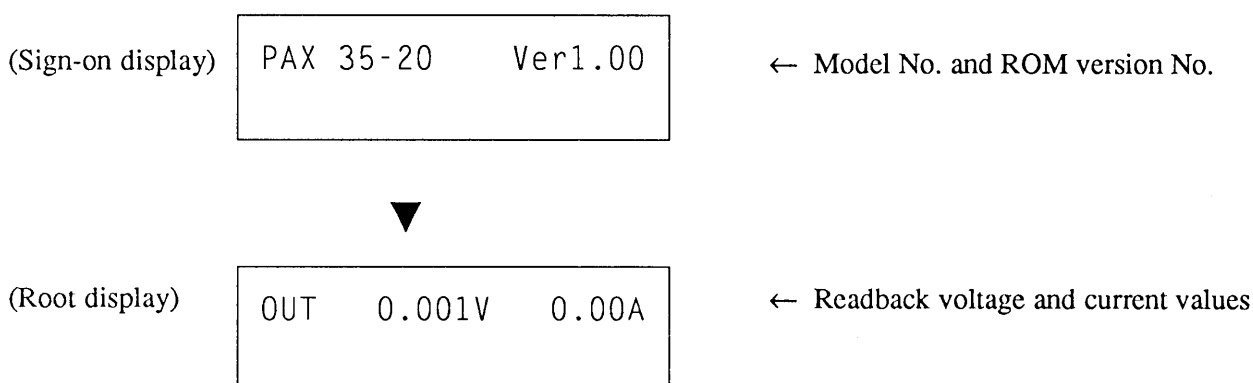

The sign-on messages differ depending on whether an interface board is installed on the power supply or not. If an interface board is installed, its type is displayed on the bottom row.

PAX 35-20 Ver1.00
 XXXX KIKUSUI

Examples for message "XXXX"

"NONE" : No interface board

"GP01" : GPIB interface board (Device address: 01)

"RS96" : RS-232C interface board (Transfer rate 9600 bps)

"MC01" : MCB interface board (Device address: 01)

NOTE

- This chapter takes Model PAX35-20 (rated voltage 35V, rated current 20A) as an example for descriptions.

3.2.2 Basic Panel Operating Method

This section describes the basic front panel operating method and the menus displayed.

[1] To select a function

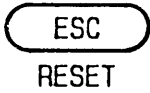

If you press a function key, the function indicated with black letters on top of the key is selected.

If you want to select the function indicated with blue letters underneath a function key, press at first the [SHIFT] key and check that the LED immediately above it has lighted, and then press the function key. For example, if you want to select the RESET function which is indicated underneath the [ESC] key, press at first the [SHIFT] key and then press the [ESC] key.

In this book, a key operation which involves pressing of the [SHIFT] key is expressed as follows:

[SHIFT] + [ESC] RESET ... Means that you should press the [SHIFT] key first and the [ESC] key next, to select the RESET function.

[2] To increase/decrease a numeric entry value

A numeric value to be entered can be increased or decreased with the numeric value entry keys or with the JOG/SHUTTLE dials.

Direct entry with numeric value entry keys

Type a value on the display with the numeric entry keys and then press the [ENTER] key.

- To ammend a value you have entered by mistake, use the following keys.
 - [CLR] : To clear all letters you have typed
 - [BS] : To delete the only one letter you typed last

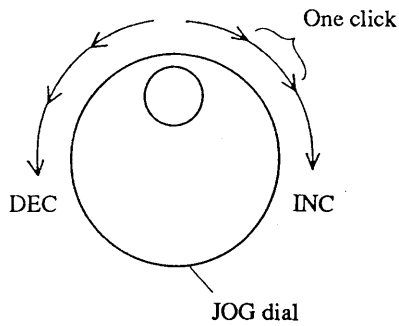
Increase/decrease with JOG dial

The value increases as you turn the dial clockwise, and vice versa.

- The amount of change per one click is JOG dial adjustable. Refer to Section 3.3.5 "Setting the Click Resolution."
- The factory default for click resolution is 0.1V/0.1A.
- One full turn of the dial is equivalent to 10 clicks.

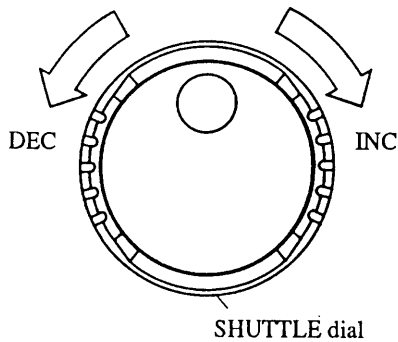
Increase/decrease with SHUTTLE dial

During the period you keep the dial in a clockwise position, the typed value increases continuously, and vice versa.

- The larger the angle you have turned the dial, the larger is the change rate.

Increase/decrease with ARROW keys

Each time you press the **▲** key, the value increases, and each time you press the **▼** key, the value decreases.

- The click resolution is identical with that of the JOG dial.

[3] Menu Selection

When a menu is displayed, a prompt ">" appears at the left hand end of the display. You can move the prompt with the numeric entry keys, JOG dial, or [▼][▲] keys.

To select with numeric entry keys

You can directly select one of the menu items by pressing the corresponding one of the numeric entry keys.

To select with JOG dial

The prompt ">" moves downward as you turn the JOG dial clockwise, and vice versa. (The prompt circulates along the menu items.) Move the prompt to the item you need and then press the [ENTER] key.

To select with ARROW keys

The prompt ">" moves upward as you press the [▲] key and it moves downward as you press the [▼] key. (The prompt circulates along the menu items.) Move the prompt to the item you need and then press the [ENTER] key.

For example, when there are four menu items, the prompt circulates along the items as follows as you press the [▲] or [▼] key or turn the JOG dial.

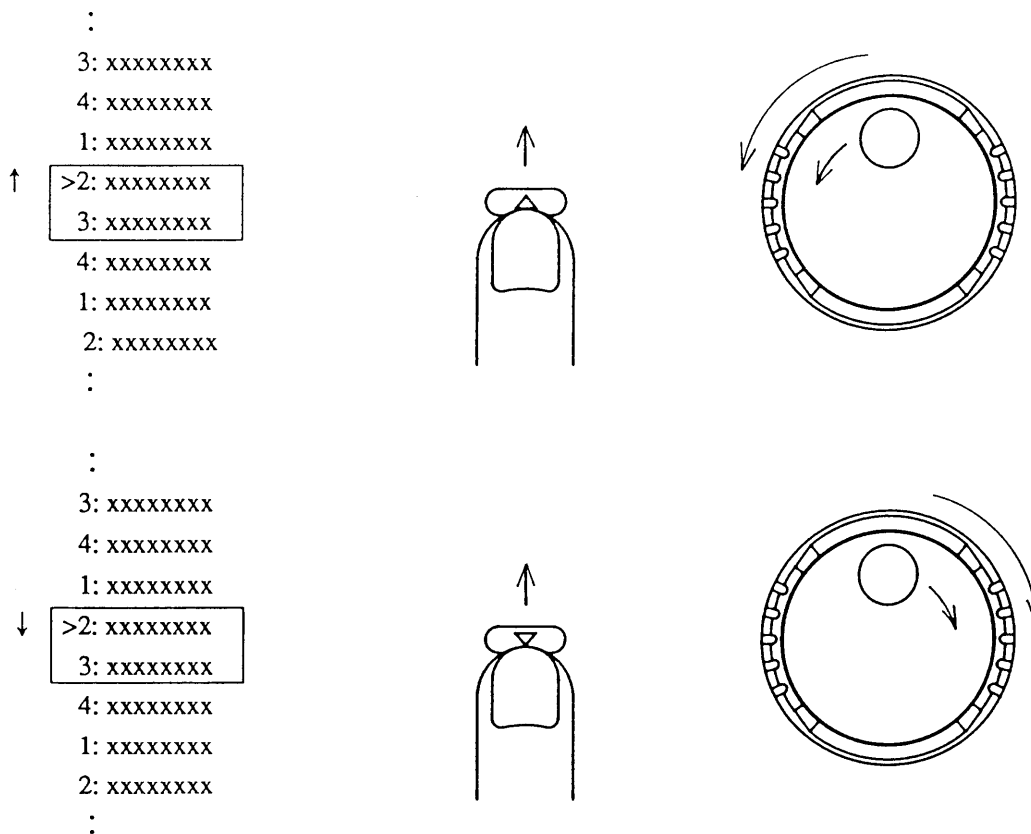

NOTE

- The power supply stores the menu item number you selected.
- When you call up the menu next time, the item number you selected last time will appear in the top row of the menu.

[4] To escape from procedure

If you want to escape from the current procedure, press the **[ESC]** key. Each time you press the **[ESC]** key, the menu which is higher by one level (the immediately preceding menu) will appear.

- Even when you have done this, the state selected by the **[OUTPUT]** key is not reset.

[5] Turning ON/OFF the output

Each time you press the **[OUTPUT]** key, the power supply output is turned ON or OFF. When in the ON state, the <OUTPUT> LED will light.

In the subsequent Sections 3.2.3 through 3.2.6, the basic operating procedures of the power supply are explained. For the explanation, the factory defaults are assumed for all settings.

3.2.3 Voltage/Current Settings and Output ON/OFF

The basic operating procedures for a power supply are to set its output voltage and current and to turn ON or OFF its output.

To set the output voltage or current, press the [V SET] or [I SET] key and then specify the required value with the JOG/SHUTTLE dials, [▲] [▼] keys, or the numeric entry keys.

Examples of Voltage Setting and Output ON/OFF Procedures

Assume that you want to set the output voltage at 5.0V directly with the numeric entry keys, to turn ON the output, to change the set value with the JOG dial, [▼] key or SHUTTLE dial, and then to turn OFF the output.

For these operations, proceed as follows:

① Press the [V SET] key.

OUT	0.001V - 0.01A
SET	0.000V 20.00A

- The <V SET> LED will light, indicating that the voltage setting mode has been selected.
- The top row of the display indicates the readback values of actual voltage and current.
- The bottom row of the display indicates the set values of voltage and current.

② Press the [5] , [.] , [0] , [0] , and [ENTER] keys in this order.

(Direct setting with the numeric entry keys)

OUT	0.001V - 0.01A
SET	5.000V 20.00A

- The typed value is entered and set as you press the [ENTER] key.

③ Press the [OUTPUT] key.

OUT	4.999V 1.23A
SET	5.000V 20.00A

- The <OUTPUT> LED will light, indicating that the output is ON.
- In this example, the <CV> LED will light as the power supply is operating in the CV (constant voltage) mode.

④ Turn the JOG dial clockwise.

OUT	5.098V 1.25A
SET	5.100V 20.00A

(Setting with the JOG dial)

- As you turn the dial clockwise, the voltage will increase with a resolution of 0.1V per click.
- The typed value is automatically entered and set each time you change it.

⑤ Press the [▼] key

OUT	4.999V 1.23A
SET	5.000V 20.00A

(Setting with the [▼] key)

- As you press the [▼] key, the voltage will decrease.
- The typed value is entered and set each time you change it.
- The resolution of change is the same as that with one click of the JOG dial.

⑥ Turn the SHUTTLE dial clockwise and then return it.

OUT	5.021V 1.23A
SET	5.020V 20.00A

(Setting with the SHUTTLE dial)

- As you turn the dial clockwise, the voltage will increase.
- The typed value is automatically entered and set each time you change it.

⑦ Press the **[ESC]** key.

OUT	5.021V	1.23A
-----	--------	-------

- The root display will appear.
- The <V SET> LED will go out, indicating an escape from the voltage setting mode.

⑧ Press the **[OUTPUT]** key.

OUT	0.001V	- 0.01A
-----	--------	---------

- The <OUTPUT> LED will go out, indicating that the output is turned OFF.

NOTE

- Even when operating the power supply without connecting any load to it, you should set the output current at a value larger than zero. If the current is set at zero, the power supply may run in the CC (constant current) mode and may not be able to be switched over to the CV (constant voltage) mode.
- By using the JOG dial, **[▲]** or **[▼]** key, voltage or current is able to set with resolution of 0.001 V. To change setting resolution, see 3.3.5 "Setting the Click Resolution".
- While you may set the output voltage with the highest resolution of 1mV at any time, the resolution of the actual output voltage is corresponding to it only when you have set the Auto Fine function to be ON. If you have set it to OFF, even when you have set, for example, the output voltage at 10.003V, the actual output voltage will be the same as that when the output is set at 10.00V.

Examples of Current Setting

To set the output current, follow a similar procedure as above but press the **[I SET]** key instead of the **[V SET]** key in Step ①. Although the display is down only to 10mA, the internal processing is with a resolution of 1mA. When setting with the numeric entry keys, if you type 19.996 for example, the display will be 19.996 and, as you press the **[ENTER]** key, the figure of the least-significant digit (1mA digit) will be rounded, and yet the actual setting within the instrument remains at 19.996A.

OUT	4.999V	1.23A
SET	5.000V	19.996A

Press the **[ENTER]** key

OUT	4.999V	1.23A
SET	5.000V	20.00A

NOTE

- If you have selected the 0.001A resolution, the 0.01A digit changes by a unit per 10 clicks with the JOG dial, **[▲]** or **[▼]** key.
- While you may set the output current with the highest resolution of 1mA at any time, the resolution of the actual output current is corresponding to it only when you have set the Auto Fine function to be ON. If you have set it to OFF, even when you have set, for example, the output current at 19.996A, the actual output current will be the same as that when the output is set at 20.00A.

Rise-up Waveform and Fall-down Waveform

The power supply is an automatic CV/CC mode switchover type. With this type of equipment, a very short switchover time between the two modes (CV mode and CC mode) is inevitable. Due to this, if the modes are rapidly switched over when the power supply is in the Fast mode, the output may transiently exceed the preset voltage or current.

For example, assume that the load is to be operated with 10V and 5A and that the power supply has been set for $V_{SET} = 10V$ and $I_{SET} = 0A$. Under these conditions, if the current setting is rapidly changed to 10A, the power supply will rise up in the CC mode and, at the instance it is switched over to the CV mode, the output voltage may exceed 10V.

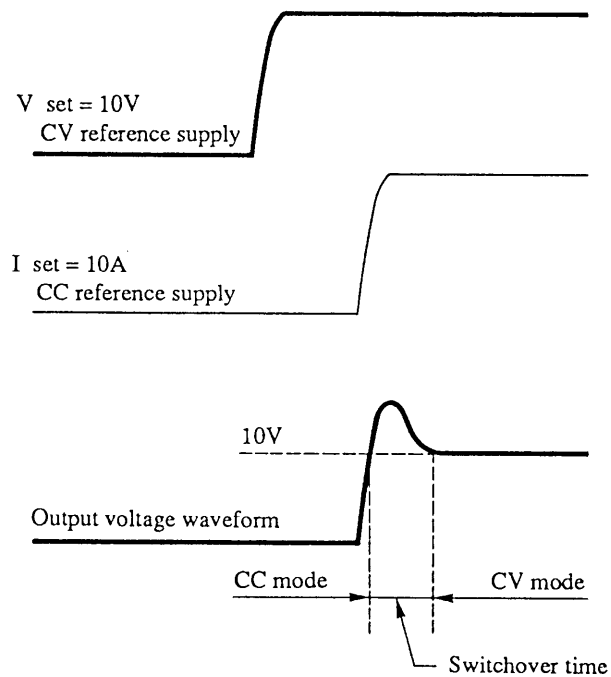

In order to avoid transiently exceeding the preset voltage, make settings so that operation is not switched over between the two modes. In the case of the above example, set the current at 5A so that the output will not exceed 10V as the modes will not be switched from CV to CC even when the voltage setting is changed from 0V to 10V.

The same matter as above applies also when the output is turned ON or OFF. In order to make the output voltage exactly zero volts when the output is turned OFF, the analog reference voltage within the power supply is reduced to zero volts and, when the output is turned ON, an analog reference voltage corresponding to the voltage setting or current setting is established. The power supply allows to change the sequence of establishing the analog reference voltage. For details, refer to Item [3] "Setting of CV/CC ON/OFF Timing" of Section 3.5.1 "Configuration."

3.2.4 Fine Setting of Output Voltage or Current

The output voltage or current can be set more finely than can be set with the regular resolution. For fine setting, an offset value is added to the value set by "V SET" or "I SET."

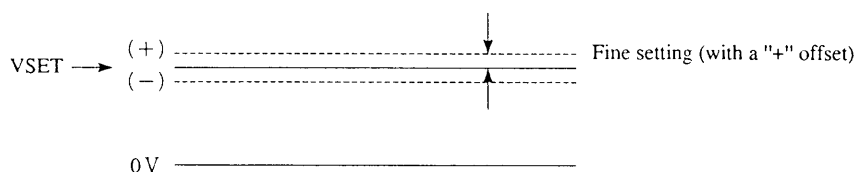

An example of Fine setting procedure

- ① When the Root display is shown, press the **[SHIFT]** + **[V SET]** V FINE keys.

```
OUT  11.999V   0.50A
V Fine +000
```

- Indicates that the Fine voltage setting mode is effected.
- (The <V SET> LED will light.)
- The bottom row indicates the Fine value.

- ② Turn the JOG dial clockwise.

```
OUT  12.002V   0.50A
V Fine +015
```

(Fine setting with the JOG dial)

- As you turn the JOG dial clockwise, the Fine value increases.
- The value is automatically entered each time it is changed.

- ③ Turn the SHUTTLE dial counterclockwise and then return it.

```
OUT  11.978V   0.50A
V Fine -040
```

(Fine setting with the SHUTTLE dial.)

- As you turn the SHUTTLE dial counter-clockwise, the Fine value decreases.
- The value is automatically entered each time it is changed.

- ④ Press the **[ESC]** key.

```
OUT  11.978V   0.50A
```

- The Root display will appear.
- The above Fine setting is maintained.

- ⑤ Press the **[V SET]** , **[1]** , **[2]** and **[ENTER]** keys in this order to set the output voltage.

```
OUT  11.999V   0.50A
SET  12.000V   20.00A
```

- At this point, the Fine value setting is automatically reset to 0.

NOTE

- Fine setting of the output current can be done in the same procedure as above but by pressing the **[I SET]** key instead of the **[V SET]** key in Step ①.
- The Fine value for voltage and that for current are mutually independent.
- The Fine values are variable in 256 steps within a range of from -128 to +127.
- During a Fine value setting procedure, the Fine value can be reset to 0 by pressing the **[CLR]** key or **[0]** key.
- If you set again the output voltage or current, its Fine value is automatically set to 0 at that moment.

Auto Fine Function

Auto Fine function is to automatically adjust the output to let it conform with the 1mV order of voltage setting or 1mA order of current setting.

When in the Auto Fine mode, software inside the instrument searches for values to make the actual voltage and current shown on the top row of the display are made equal with the set values. Due to this, a certain time (1.5 seconds maximum) is needed before the output voltage and current are settled at the set values.

3.2.5 Setting of Protective Actions

The primary objective of the protective functions is to protect the load against overvoltage and overcurrent. The power supply allows you to set an OVP (overvoltage protection) level and OCP (overcurrent protection) level, and to select the actions the power supply should take when a protector has tripped. The power supply also allows you to set automatic software OVP and OCP trip levels.

Hardware Protectors and Software Protectors

Hardware OVP and Hardware OCP

You can set the trip levels of OVP and OCP with the potentiometers on the front sub-panel. We call these protectors as hardware OVP and hardware OCP because the trip levels are directly set on the protective circuits (hardware).

Software OVP and Software OCP

You can set the trip levels of OVP and OCP by key operation of the front panel. The trip levels are set via a D/A converter. We call these protectors as software OVP and software OCP because the trip levels are set via software processing.

NOTE

- *It is most recommendable to double-protect the power supply with the software protectors (primary protectors) and the hardware protectors (secondary protectors). The protectors are referred to as "primary" and "secondary" in view of their alarm handling actions.*

Menu Configuration and Functions of Protectors

Initial menu of protectors

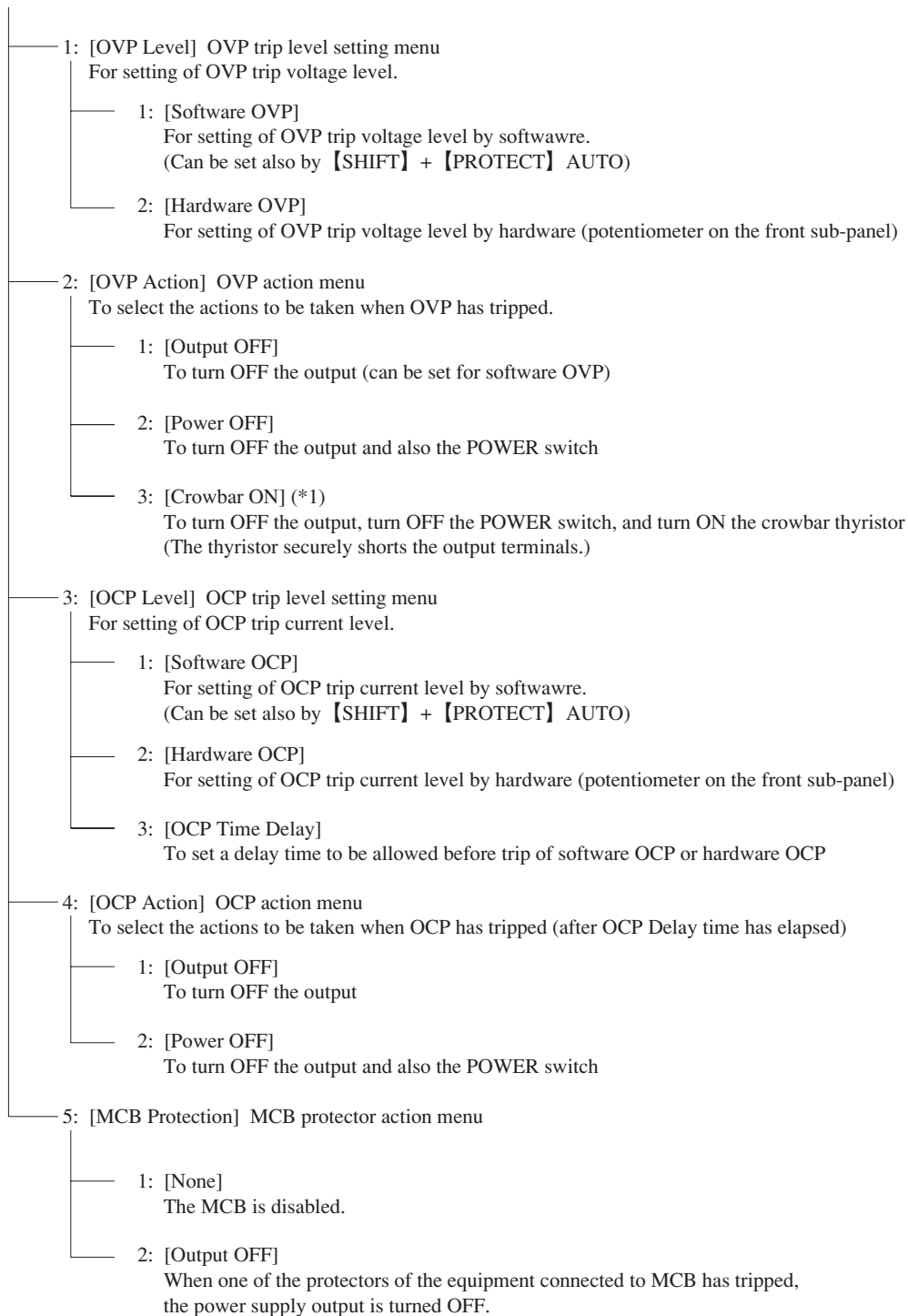

*1 3:[Crowbar ON] is optional function. If select it on default status, "Does not Exist" will appear.

NOTE

- The alarm action by the hardware OVP is such that the POWER switch is immediately turned OFF when the OVP has tripped.
- With the hardware OCP, the current limit function is maintained until the alarm handling actions are taken after the OCP has tripped.
- Protection by the MCB takes place in synchronization with a trip of a protector of other equipment connected to the power supply via an MCB interface board (optional).

Examples of setting the OVP trip voltage and selecting the alarm handling actions

① Press the [PROTECT] key.

```
>1: OVP Level
  2: OVP Action
```

(Initial menu for protector setting)

- Items 1 and 2 of the five menu items (1 through 5) will appear.
- To scroll the menu items, use the JOG dial or [▲] [▼] keys.

② Press [1] to select [OVP Level].

```
>1: Software OVP
  2: Hardware OVP
```

(OVP protection select menu)

③ Press the [ENTER] key to select [Software OVP] of the top row.

```
Software OVP Level
          38.5V
```

- The top row indicates that a software trip level can be entered.
- The bottom row indicates that the currently existing trip level is 38.5V.

④ Press the [3], [6], and [ENTER] keys in this order.

```
Software OVP Level
          36.0V
```

- Indicates that the newly entered software trip level is 36.0V.
- The value for the trip level is variable with the JOG/SHUTTLE dials also.

▼ When about one second has elapsed

```
>1: Software OVP
  2: Hardware OVP
```

The OVP protection select menu will resume.

⑤ Press the [2] key to select [Hardware OVP].

```
Hardware OVP 39.4V
```

- The currently existing hardware OVP trip level will be displayed.

⑥ Turn counterclockwise the OVP control (potentiometer at upper right on the front sub-panel).

```
Hardware OVP 38.5V
```

- Adjust with the potentiometer the OVP trip level to the value you may require.

⑦ Press the [ESC] key twice.

```
>1: OVP Level
  2: OVP Action
```

- ⑧ Press the **▼** key and **[ENTER]** key in this order, to select **[OVP Action]**.

```
>2:OVP Action
>1:<Output OFF>
```

(OVP action select menu)

- The item enclosed in <> is the currently existing setting for OVP action.

- ⑨ Press the **[1]** key to select **[Output OFF]**.

```
OVP Alarm Action
Output OFF
```

- In this example, since the action has already been selected, you may press the **[ESC]** key instead.

▼ When about one second has elapsed

```
>2: OVP Action
3: OCP Level
```

- After the setting is over, the protection select menu will resume.

- ⑩ Press the **[ESC]** key.

```
OUT 0.001V - 0.00A
```

- The root display will resume.

- For overcurrent protection (OCP) also, you can set the trip level and select alarm actions in a similar manner as that for OVP.

Examples of OVP/OCP trip level setting with AUTO function

The AUTO function is such that the trip level of software OVP or software OCP is automatically set in percentage (110%, 120% or 130%) of the set value of output voltage or current.

For example, assume that the percentage is 110%, the set voltage is 15V, and the set current is 10A. If the AUTO function is brought into effect under these conditions, the software OVP trip level will be 16.5V and the software OCP trip level will be 11A.

- ① When the root display is shown, press the **[SHIFT] + [PROTECT] AUTO** keys.

```
OUT 15.000V 2.50A
Auto Protection 110%
```

- The software OVP and OCP trip levels are set.
- In this example, the percentage for the AUTO function is 110% of the set value of the output voltage or current.

▼ When about one second has elapsed

```
OUT 15.000V 2.50A
```

NOTE

- The factory default for the percentage is 110%.
- For the percentage change procedure, refer to Section 3.5.1 "Configuration."

3.2.6 To Reset from Protection Alarm Status

To reset from the alarm status caused by a trip of one of the protectors, press the **[SHIFT] + [ESC]** RESET keys.

Examples of Procedure for Resetting from Protection Alarm Status

- ① Set the software OVP at 35V, the OVP action to "Output OFF," and the output voltage at 34V. Turn ON the output.

OUT	34.000V	1.00A
SET	34.000V	10.00A

- ② Turn clockwise the JOG dial to increase intentionally the output voltage until it exceeds the OVP trip level and the OVP trips.

OUT	35.000V	1.03A
SET	35.000V	10.00A

- With the settings of this example, the OVP will trip at 35V and the output will be turned OFF and an alarm state will result.

▼ OVP!!

OUT	0.00V	0.00A
Alm	OVP	

- The alarm is annunciated by the buzzer and <LIMIT> LED.

- ③ Press the **[SHIFT] + [ESC]** RESET keys.

OUT	0.00V	0.00A
-----	-------	-------

- The alarm will be reset.
- The output will remain OFF.

- ④ Set again the output voltage at 34V and then press the **[OUTPUT]** key.

OUT	34.000V	1.00A
-----	---------	-------

- Eliminate the cause of the OVP trip.
- The <OUTPUT> LED will light.

NOTE

- Be sure to reset the alarm before doing any other panel operation.

Examples of alarm displays

OVP

OUT	0.000V	0.00A
Alm	OVP	

OCP

OUT	0.000V	0.00A
Alm	OCP	

OHP

OUT	0.000V	0.00A
Alm	OHP	

MCB

OUT	0.000V	0.00A
Alm	MCB	

NOTE

- If two or more alarms occur simultaneously, the contents of respective alarms are displayed.
- The OHP is a built-in overtemperature protector of the power supply. Its alarm handling action is "Output OFF." If the alarm cannot be reset by pressing the RESET key, fully cool off the power supply and then press the RESET key again.

3.3 Basic Operating Method 2

3.3.1 Remote Sensing Function

The remote sensing function is to sense the supply voltage at the load and feed back the sensed voltage to compensate for the voltage drops that are caused by cable resistances and contact resistances of the cabling from the power supply to the load. This function can be used when the power supply is in the Normal mode.

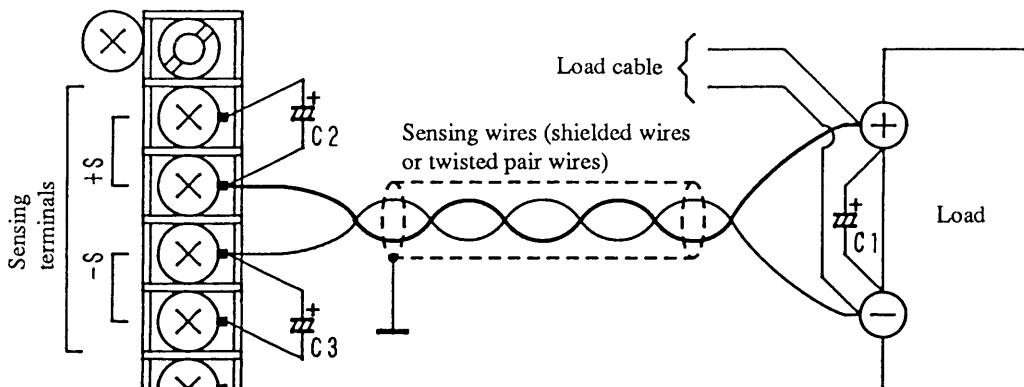

Caution

- The remote sensing function can be used only when the power supply is operating in the Normal mode. (When in the Fast mode, the performance specifications of the power supply may not be met.)
- Be certain that the sensing wires and the load cables are securely connected. If even a single one of these wires or cables is disconnected and its circuit is made open, both power supply and load can be seriously damaged.
- Be sure to install the cover of the terminal block.
- When the load is a battery or other regenerative type of device, connect the load cables before connecting the sensing wires.
- If you are installing an ON/OFF switch in the load cable line, install also in the sensing wire line an ON/OFF switch which is linked to the ON/OFF switch of the load cable line.

NOTE

- Connect the "+" sensing wire to the "+" load terminal and the "-" sensing wire to the "-" load terminal by using shielded wires or twisted pair wires.
- Up to 0.5V of voltage drop per one way of cabling from the power supply to the load can be compensated for.
- Be sure to connect an electrolytic capacitor (C1 in the above illustration) of several thousands microfarads to the sensing point.
- If the sensing distance is long and the voltage is unstable, connect capacitors (C2 and C3 in the above illustration) of several hundreds microfarads to the sensing terminals. (Be sure to connect the capacitors in the correct polarity. Their working voltages must be 50WV or higher.)

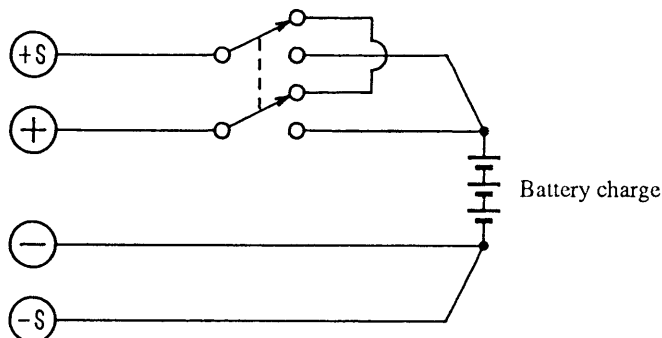

- The remote sensing function is unrecommendable for a load whose current changes rapidly. The output voltage will be more stable without the remote sensing function.

3.3.2 Memory Function

The memory function allows you to store up-to-four sets of voltage and current setting data in four memory units and to recall the saved setting data from the memory units.

[1] To Store Voltage and Current Setting Data in Memory

To save the currently existing output voltage and current settings and the Fine voltage and current settings, when the root display is on the LCD, press the **【SHIFT】** + **【3】** MEM STORE keys, press one of the **【A】** through **【D】** keys or turn the JOG dial to select a memory unit, and then press the **【ENTER】** key. The setting data will be saved in the corresponding one of the memory units A, B, C, and D.

Example of procedure to save setting data

OUT	15.321V	1.51A
-----	---------	-------

- Specify the setting data (voltage, current, and Fine values) in beforehand.

① When the root display is on the LCD, press the **【SHIFT】** + **【3】** MEM STORE keys.

OUT	15.321V	1.51A
S A	0.000V	20.00A

- The bottom row indicates the currently selected memory (memory A in this example).
- You can recall the contents of memory A through D by turning the JOG dial.

② Press the **【A】** key.

OUT	15.321V	1.51A
S A*	15.300V*	3.00A

- The voltage and current setting data has been saved.
- To save the setting data, you may press the **【ENTER】** key instead of the **【A】** key.
- The bottom row indicates the newly saved data. The asterisk (*) mean that the Fine value of voltage or current is not zero.

▼ When about one second has elapsed

OUT	15.321V	1.51A
-----	---------	-------

- The root display will resume.

NOTE

- The factory-defaults for the setting data stored in memory are voltage at 0.000V, current at the rated value, and Fine values at 0.

[2] To Recall Voltage and Current Setting Data from Memory

To recall the saved voltage and current settings and the Fine values, when the root display is on the LCD, press the **[MEMORY]** keys, press one of the **[A]** through **[D]** keys or turn the JOG dial to select a memory, and then press the **[ENTER]** key.

Example of setting data recall procedure

OUT	0.001V	0.01A
SET	0.000V	0.00A

- For convenience of explanation, the settings assumed here are that the voltage and current are zero and the output is ON.

① Press the **[MEMORY]** key.

OUT	0.001V	0.01A
M A*	15.000V*	3.00A

- The <MEMORY> LED will light.
- The bottom row shows the setting data recalled from memory (memory A in this example).
- You can recall the contents of memory A through D by turning the JOG dial.

② Press the **[A]** key.

OUT	14.999V	1.00A
M A*	15.000V*	3.00A

- The voltage and current setting data of memory A has been called out.
- The asterisk (*) means that the Fine value of voltage or current is not zero.

③ Recall the contents of memory **[D]** by turning the JOG dial.

OUT	14.999V	1.00A
M D	14.750V	20.00A

④ Press the **[ENTER]** key.

OUT	14.751V	0.98A
M D	14.750V	20.00A

- The voltage and current settings and their Fine values are saved in memory D.

⑤ Press the **[ESC]** key.

OUT	14.751V	0.98A
-----	---------	-------

- The root display will resume.
- The <MEMORY> LED will go out.

Caution

- Before directly recalling the saved settings by pressing the **[A]** or other key, check the saved settings (voltage and current settings). The saved states can be displayed by turning the JOG dial.

3.3.3 Setup Function

The power supply can store the various items of setting data, including the output voltage and current settings, and OVP, Tr and Tf settings. The setup function is for handling these settings collectively as a certain setup of the power supply, for convenience of storing and recalling the settings.

Setup Function Menu Configuration and Actions

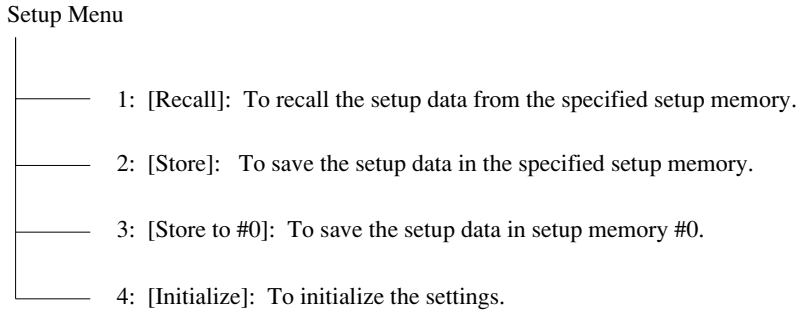

Conceptual Diagram of the Setup Function

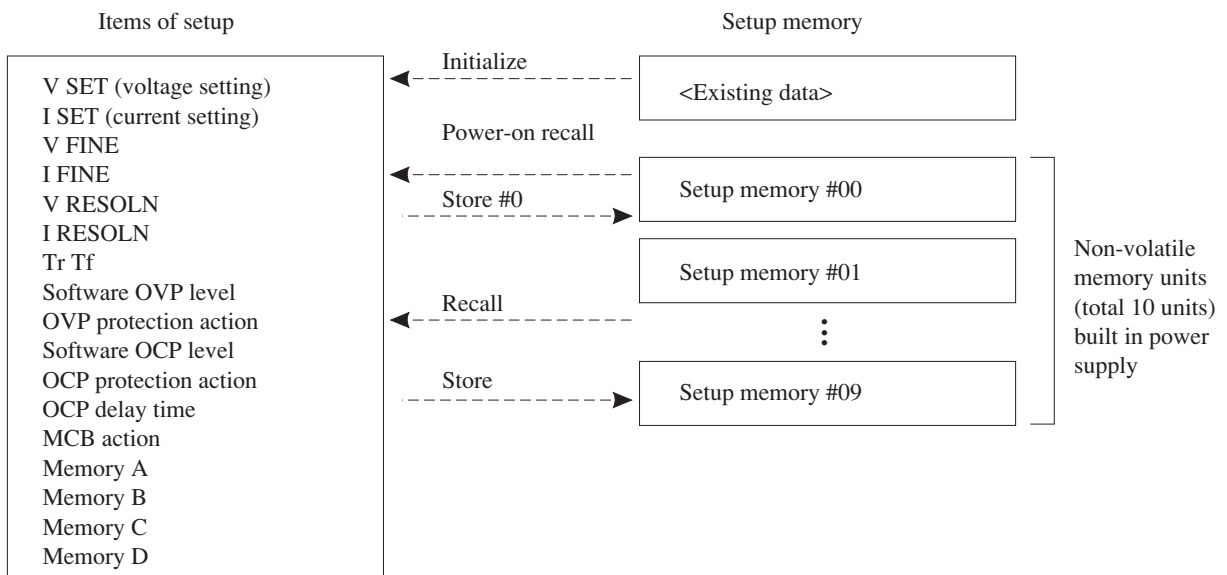

NOTE

- When the POWER switch is turned ON, the contents of setup memory #0 is recalled. (Power-ON recall function)
- Such setting also is possible that the output is automatically turned ON when the POWER switch is turned ON. (For more information, refer to Section 3.5.1 "Configuration.")

Display of Setup Function

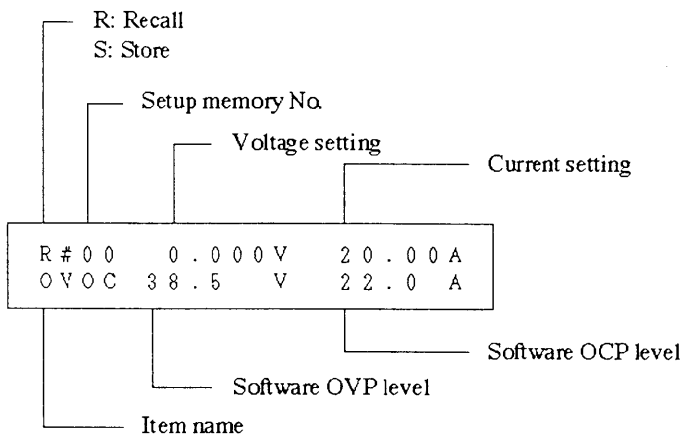

As you press the [◀] [▶] key, the display will change as follows:

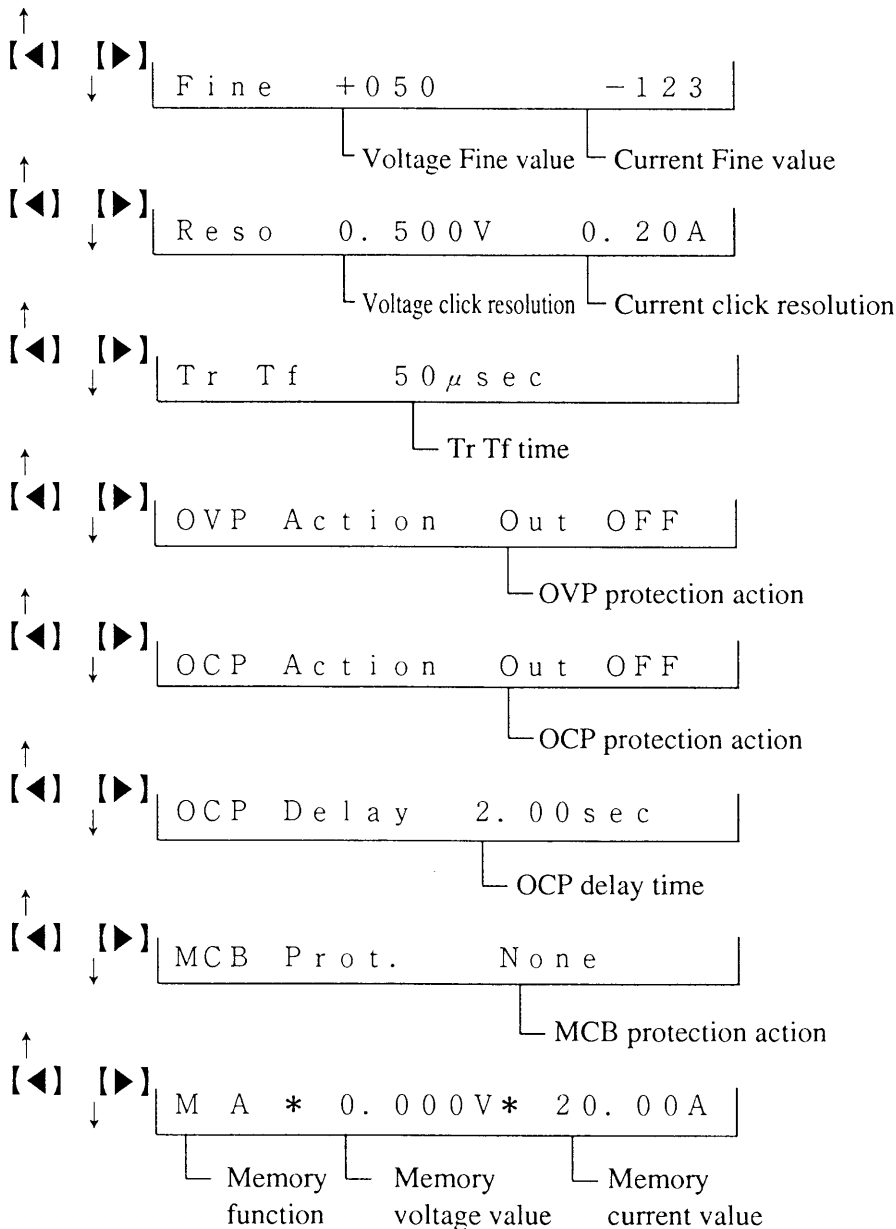

(* denotes that the Fine value is not zero.)

[1] Recall

This function is to call out the setup data saved from the specified memory.

Example of procedure to recall a setup from memory

- ① Press the **[SHIFT]** + **[7]** SETUP keys.

>1: Recall
2: Store

(Setup menu)

- Menu items 1 and 2 (of total menu items 1 through 4) are displayed.

- ② Press the **[ENTER]** key to select the [Recall] of the top row.

R#00	0.000V	20.00A
OVOC	38.5 V	22.0 A

- ③ Press the **[▶]** key.

R#00	0.000V	20.00A
Fine	+000	+000

- Other items of the same setup can be displayed with the **[◀]** **[▶]** keys.

- ④ Press the **[▼]** key.

R#01	5.000V	3.00A
Fine	+000	+000

- The setup memory numbers can be changed with the **[▲]** **[▼]** keys or the JOG dial.

- ⑤ Press the **[ENTER]** key.

Recall Setup
Completed.

- The setup has been recalled.

▼ When about one second has elapsed

OUT	0.001V	0.01A
-----	--------	-------

- ⑥ Press the **[OUTPUT]** key.

OUT	5.000V	1.00A
-----	--------	-------

- The power supply will operated with the recalled setup.

Caution

- For the sake of safety, the output is automatically turned OFF when the contents of a setup memory is recalled.

[2] Store

This function is to save the setup data in the specified setup memory.

Example of procedure to save a setup in memory

① Press the **[SHIFT]** + **[7]** SETUP keys.

```
>1: Recall
  2: Store
```

(Setup menu)

- Menu items 1 and 2 (of total menu items 1 through 4) are displayed.

② Press the **[2]** key to select the [Store].

```
S#00  0.000V  20.00A
OVOC  38.5   V  22.0  A
```

③ Press the **[▶]** key.

```
S#00  0.000V  20.00A
Fine  +000    +000
```

- Other items of the same setup can be displayed with the **[◀]** **[▶]** keys.

④ Press the **[▼]** key.

```
S#01  5.000V   3.00A
Fine  +000    +000
```

- The setup memory numbers can be changed with the **[▲]** **[▼]** keys or the JOG dial.

⑤ Press the **[ENTER]** key.

```
Store Setup
Completed.
```

- The setup data has been stored in memory.

▼ When about one second has elapsed

```
OUT   0.000V - 0.00A
```

[3] Store #0

When the POWER switch of the power supply is turned on, the power supply recalls the contents of setup memory #0 by its Power-ON Recall function. The function saves the currently existing setup in setup memory #0 and, when the AC input POWER switch is turned ON the next time, the function lets the power supply recall the setup that has been saved in setup memory #0.

Example of procedure to save a setup in setup memory #0

- ① Press the [SHIFT] + [7] SETUP keys.

```
>1: Recall
  2: Store
```

- ② Press the [3] key to select the [Store to #0].

```
Store to #0
Completed.
```

- The setup data has been saved in setup memory "#0".

▼ When about one second has elapsed

```
OUT   5.001V   1.01A
```

NOTE

- The [Store to #0] procedure is identical with the [Store] procedure to save the setup data in setup memory #0.

[4] Initialize

This function is to initialize the settings to the factory-defaults.

Example of procedure to initialize the settings

① Press the [SHIFT] + [7] SETUP keys.

```
>1: Recall  
2: Store
```

(Setup menu)

② Press the [4] key to select the [Initialize].

```
Initialize Setup  
Sure ?
```

- A message requesting your confirmation will appear.

③ Press the [ENTER] key to select the [Initialize].

```
Initialize Setup  
Completed.
```

- The settings have been initialized to the factory-defaults.

▼ When about one second has elapsed

```
OUT 0.000V 0.00A
```

- The power supply has been initialized and the output is OFF.

NOTE

- For the factory-default settings, refer to Appendix 3 "Table of Factory-Defaults."

3.3.4 Keylock Function

This function disables all front panel keys and controls including the JOG/SHUTTLE dials, but enables only the keylock release procedure ([SHIFT] + [1] KEYLOCK) and alarm reset procedure ([SHIFT] + [ESC] RESET).

Example of keylock procedure

- ① Press the [SHIFT] + [1] KEYLOCK keys.

```
OUT   0.001V   0.01A
<< Keys Locked >>
```

- The keys are locked.

- ② Press again the [SHIFT] + [1] KEYLOCK keys.

```
OUT   0.001V   0.01A
SET   5. V     20.00A
```

- The keylock state is released and the former state resumes.
- In this example, the display indicates that the keylock function was effected when in voltage setting (immediately after pressing the [V SET], [5], and [.] keys).

- ③ Press the [ESC] key.

```
OUT   0.001V   0.01A
```

- The root display will resume.

Caution

- *When the OCP or other protector has tripped and an alarm has occurred while in the keylock state, reset the alarm at first by pressing the [SHIFT] + [ESC] RESET keys. Then, the keylock state will be automatically released.*

3.3.5 Setting the Click Resolution

To set a click resolution for the JOG dial and **▲** **▼** keys, when in a state that the voltage or current setting can be done, press the **SHIFT** + **6** RESOLN keys and adjust the click resolution with the JOG/SHUTTLE dials or the numeric entry keys.

Example of voltage click resolution setting procedure

① Press the **V SET** key.

OUT	0.001V	0.01A
SET	0.000V	20.00A

- Select the state for voltage setting.
- The <V SET> LED will light.

② Press the **SHIFT** + **6** RESOLN keys.

OUT	0.001V	0.01A
Resolution	0.100V	

(The state for click resolution setting)

- The bottom row indicates the currently existing click resolution.

③ Press the **.** , **5** , and **ENTER** keys in this order.

OUT	0.001V	0.01A
Resolution	0.500V	

(Setting with numeric entry keys)

- You may use JOG/SHUTTLE dials instead. When you do this, the setting ends as you press the **ESC** key.

▼ When about one second has elapsed

OUT	0.001V	0.01A
SET	0.000V	20.00A

④ Press the **▲** key and set a relative voltage.

OUT	0.001V	0.01A
SET	0.500V	20.00A

- The click resolution for voltage setting has been changed to 0.5V.

NOTE

- The click resolution for current setting also can be set with a procedure similar as above but by pressing the **I SET** key instead of the **V SET** key in Step 1.
- The adjustable range of click resolution is from 0.001 to a little less than a half of the rated output. The factory-defaults are 0.100V and 0.100A.

3.3.6 Setting the Rise/Fall Time

This procedure is to set the rise time (Tr) and fall time (Tf) of the voltage or current. To do this, when the output is OFF, press the [SHIFT] + [8] Tr Tf keys to call out the menu. For the Fast mode, you can select 50 μ s, 500 μ s, or 5ms.

Example of rise/fall time setting procedure

- ① Be certain that the output is OFF. If it is ON, turn it OFF by pressing the [OUTPUT] key.

```
OUT  0.001V  0.01A
```

- Before setting Tr Tf, make it double sure that the output is OFF.

- ② Press the [SHIFT] + [8] Tr Tf keys.

```
Tr Tf
>1:<50 usec>
```

(Tr Tf select menu)

- The value enclosed in <> is the existing Tr Tf time setting.

- ③ Turn the JOG dial clockwise by two clicks.

```
Tr Tf
>3: 5 msec
```

- This example is for setting the value with the JOG dial. You may set it with the numeric entry keys instead.

- ④ Press the [ENTER] key.

```
Tr Tf
5 msec
```

▼ When about one second has elapsed

```
OUT  0.001V  0.01A
```

- Setting of the Tr Tf time is complete.

NOTE

- Setting of Tr Tf time cannot be done when the output is ON or when in the Normal mode (when the short bar of the operating mode terminals on the rear panel is connected for "NORMAL.")
- The same Tr Tf time applies to both voltage and current.
- The factory-default for Tr Tf time is 50 μ s.
- The Tr Tf time is not applicable to rise up or fall down of the output when the output is turned ON or OFF.
- For more information about Tr Tf time, refer to Chapter 7.

3.3.7 Displaying the Interface Status

This procedure is to display the status of the optional interface board. To display the status, when the root display is shown, press the [SHIFT] + [CLR] IBST keys. As you press again these keys, the status display will disappear.

Example of procedure for displaying the interface status

① Press the [ESC] key to call out the root display.

```
OUT    0.001V    0.01A
<< Remote >>
```

- The message [<< Remote >>] means that the power supply is being remote-controlled via the interface.

② Press the [SHIFT] + [CLR] IBST keys.

```
OUT    0.001V    0.01A
<< Remote >>  TLS
```

- [T] stands for talker, [L] for listener, and [S] for service request.

③ Press the [SHIFT] + [CLR] IBST keys.

```
OUT    0.001V    0.01A
<< Remote >>
```

NOTE

- *The interface status is effective when the power supply is being remote-controlled through GPIB.*
- *You can return the power supply to the local control mode (mode that the front panel keys are enabled) by pressing the [SHIFT] + [BS] LOCAL keys.*

3.4 Sequence Operation

The sequence operation is such that the power supply automatically executes a programmed sequence of output voltage and current. By using the sequence mode of operation, you can let the power supply generate voltage and current in waveforms as you may require, Each sequence control program can be saved in a "sequence file" can be recalled as you require it.

3.4.1 Description of Sequence Operation

[1] Modes of sequence operation

The modes of sequence operation are classified as follows by the execution speed and by the output voltage and current.

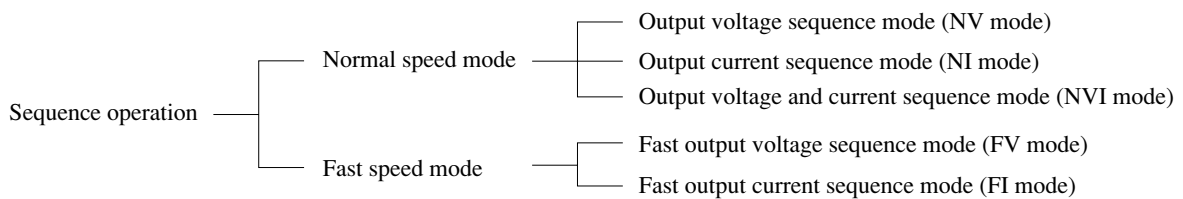

NOTE

Individual modes are as described below.

NV mode: The output voltage alone is sequence-controlled. During the sequence operation, the output current is maintained at the value which existed immediately before entering the sequence mode.

NI mode: The output current alone is sequence-controlled. During the sequence operation, the output voltage is maintained at the value which existed immediately before entering the sequence mode.

NVI mode: Both output voltage and current are sequence-controlled.

FV mode: The output voltage alone is sequence-controlled in the Fast mode. During the sequence operation, the output current is maintained at the value which existed immediately before entering the sequence mode.

FI mode: The output current alone is sequence-controlled in the Fast mode. During the sequence operation, the output voltage is maintained at the value which existed immediately before entering the sequence mode.

Examples of output voltage waveforms generated by sequence operation

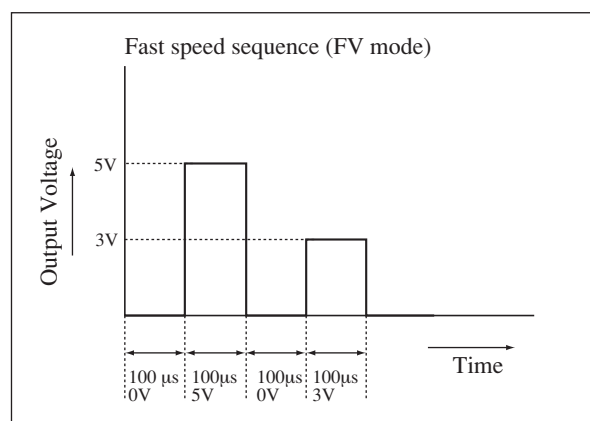
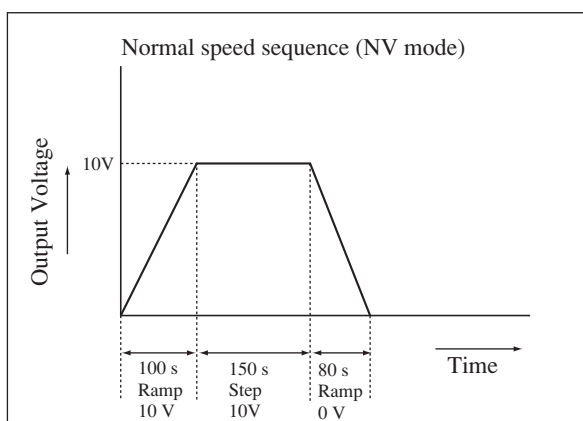

The features of the Normal speed mode and Fast speed mode of sequence operation are compared in the following table.

	Normal speed mode	Fast speed mode
Available output (Mode)	NV, NI, and NVI	FV and FI
Execution time per step (Time unit)	1. Millisecond range (0, 1ms to 9999ms) 2. Second range (0, 0.1s to 999.9s) 3. Minute range (0, 1s to 999min 59s) 4. Hour range (0, 1min to 999h59min) (Can be set as required for each step within the same range) (Execution time 0 means that the step is to be skipped.)	0.1ms to 100.0ms (Per step; fixed time)
Type of output change	Step change or ramp change	Step change
Trigger input/output function (TRIG I/O terminal)	Available (Select either trigger input or trigger output.)	Available (Trigger output only)
Output ON/OFF	Available	Unavailable (Enabled only when in the ON state)
Pause function	Available	Unavailable
Maximum number of steps	256	1024
Number of loops	1 to 9998, and infinite (by specifying 9999)	1 to 9998, and infinite (by specifying 9999)
Number of sequences	8	8
Number of programs	16	16

Caution

- *The Fast speed sequence is available only when the power supply is in the Fast mode. (Refer to Section 2.4 "Operating Mode Selection" .)*
- *The output voltage and current rises or falls with the Tr Tf time setting. Therefore, when the programmed execution time for one step is shorter than Tr Tf time, the output may not reach the values specified by the program.*
- *At the fast speed sequence operation mode when two programs of one step or two steps chained each other are executed at high speed, normal processing may not be done by the occurrence of a reception error for a message through RS-232C. Change programming of the sequence or control the Electronic Load via GPIB.*
- *It takes several tens milliseconds for processing time when the output of PAX series is turned ON or OFF.*
Pay attention to the execution time per step when using the output ON/OFF function in the normal speed sequence operation.
When the execution time per step is less than about 100 ms, the step may not be executed in the setting time.

[2] Sequence File Configuration

For sequence operation, you must prepare sequence files which contain operation parameters such as voltage, current, and time. The sequence file can be stored in the internal memory (nonvolatile memory) of the power supply.

The sequence files are classified by the execution speed into two types as follows:

Sequence file for Normal speed mode

Mode NV/NI/NVI
Time unit
Sequence 1 Execution program No. (Pxx) Number of loops (Lxxxx) End program No. (Exx) Chain sequence No. (Cx)

Sequences 2 through 8
Prgram 01 Number of steps n ----- Step 1 S/R V value S/R I value Trigger output 1/0 Output ON/OFF Pause 1/0 Execution time ----- Steps 2 to n
Programs 02 to 16

- Type of operation
- Execution time unit per step
- Parameters for "how to execute"
- The program number of the program to be executed.
- The number of repetitions of program Pxx
- The program number of the end program after completing the execution (The first step alone of the end program is executed.)
- The sequence number of the sequence to be executed next.
- Sequences 2 through 8 have the same parameters as sequence 1 has.
- Parameters for "what to execute"
- The number of steps (1 to 256)
- S (step) or R (ramp) for CV change
- Target CV value
- S (step) or R (ramp) for CC change
- Target CC value
- To deliver a trigger output or not
- To turn ON or OFF the output
- To pause the step or not
- Execution time of the step
- The same parameters as those of program 01 are assigned to programs 02 through 16.

Sequence file for Fast speed mode

Mode FV/FI
Sequence 1 Execution program No. (Pxx) Number of loops (Lxxxx) End program No. (Exx) Chain sequence No. (Cx) Execution time (Time)

Sequences 2 through 8
Prgram 01 Number of steps n ----- Step 1 V value I value Trigger output 1/0 ----- Steps 2 to n
Programs 02 to 16

- Type of operation
- Parameters for "how to execute"
- The program number of the program to be executed.
- The number of repetitions of program Pxx
- The program number of the end program after completing the execution (The first step alone of the end program is executed.)
- The sequence number of the sequence to be executed next.
- Execution time of the step
- Sequences 2 through 8 have the same parameters as sequence 1 has.
- Parameters for "what to execute"
- The number of steps (1 to 1024)
- Step number
- Target CV value
- Target CC value
- To deliver a trigger output or not
- The same parameters as those of program 01 are assigned to programs 02 through 16.

[3] Description of sequence operation parameters

Steps

The steps define sequence parameters such as voltage and current. The steps are sequentially executed starting by Step No. 1. The steps are the most basic parameters of sequence operation.

Programs

Each program consists of steps. Up to 256 steps (1024 steps when in FV or FI mode) can be assigned to up to 16 programs. The programs define the basic patterns of sequence operation. Even a single program can be executed.

Sequences

The sequences define what programs should be executed in what manner. For example, the sequence define the number of repetitions of the program and the end state of the program.

The relationships among the steps, programs, and sequences are as shown below:

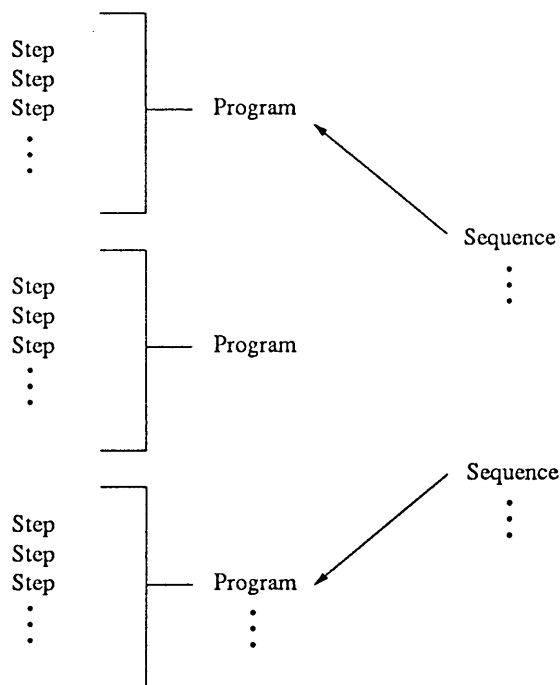

Output change

Step change: The output changes stepwise.

- Example of step change for 1sec/10V

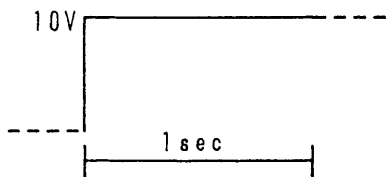

Ramp change: The output changes rampwise.

- Example of ramp change for 1sec/10V

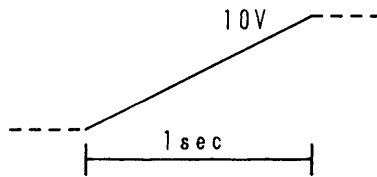

Trigger output

This parameter is for delivering a trigger pulse output via the front sub-panel, each pulse representing an event of program step change.

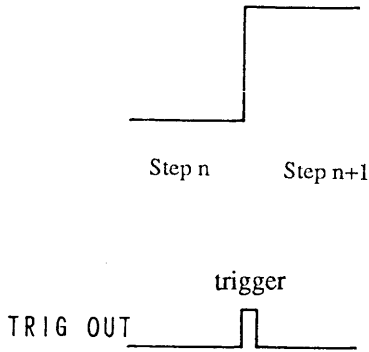

Pause and trigger input (for NV, NI, NVI modes only)

You can pause the sequence operation by pressing the [PAUSE] key. The sequence operation resumes as you press the [PAUSE] key again or a trigger input is applied via the TRIG I/O terminal of the front sub-panel.

- Example of pause by [PAUSE] key and resumption by trigger input

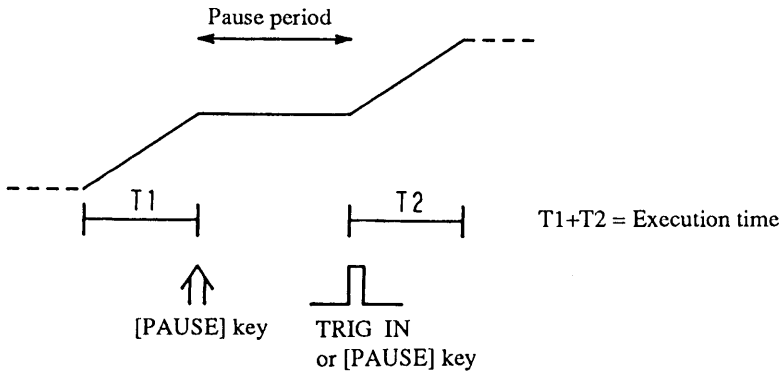

- Example of pause by program and resumption by trigger input

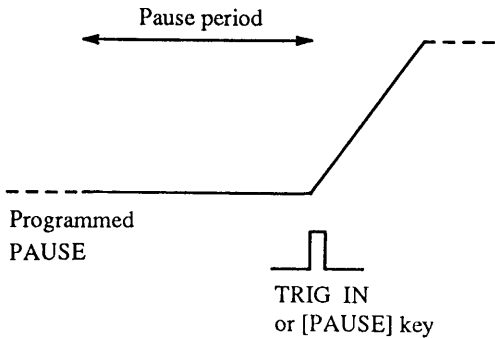

NOTE

- For the electrical specifications of the TRIG I/O terminal, refer to Section 7.1 "Electrical Specifications."

Example of sequence operation (Normal speed mode)

An example of sequence operation is introduced below to show the functions of steps, programs, and sequences.

In this example, as sequence 1 is executed, the power supply performs a sequence operation of a configuration as shown below.

Sequence 1: Execute program 1 once, and chain it to sequence 2.

Sequence 2: Execute program 2 twice, and chain it to sequence 3.

Sequence 3: Execute program 3 once, and terminate the operation at the first step of program 16 (end program).

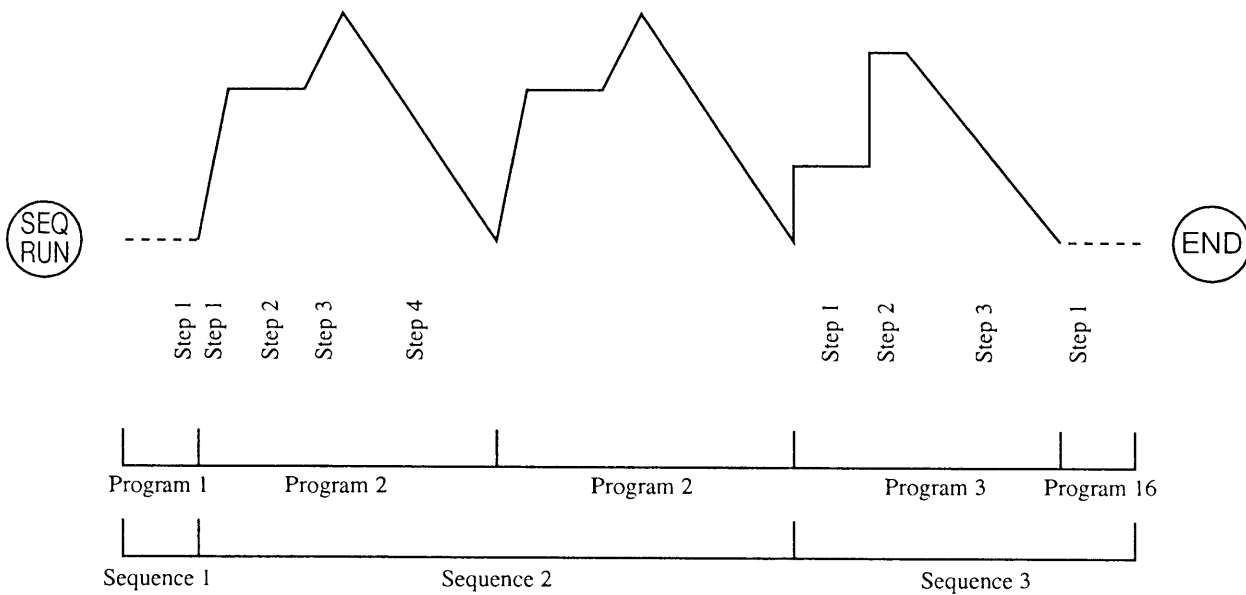

NOTE

Note on Sequence Executing

- You can specify the sequences and programs in any order.
- You cannot chain a program to another sequence which is stored in another file.
- Of the end program, the first step alone is executed. Therefore, its pause and time data is meaningless.
- Before entering the end program, a certain time interval (several milliseconds to several tens milliseconds) is necessary.
- When chain operation is specified, the end program is not executed and the operation advances to the sequence number of the destination of chain operation.
- If you stop forcibly the sequence operation by pressing the [STOP] key or by other means, the first step of the end program of the currently-executed sequence number is executed. If end program is not specified (end program is not specified when "E * *"), the operation terminates at the step which has been under execution when the stop command is given.

Note on Fast Sequence Executing

- When sequences are chained, the final step execution time of a program is not guaranteed. Use great care when using the chained sequence.

3.4.2 Outline of Settings for Operation

For sequence operation, you must manage sequence files, create and edit sequence parameters, and then execute the sequences. Set the required items by following the procedure indicated by menus.

Sequence operation menu configuration and functions

Initial sequence menu

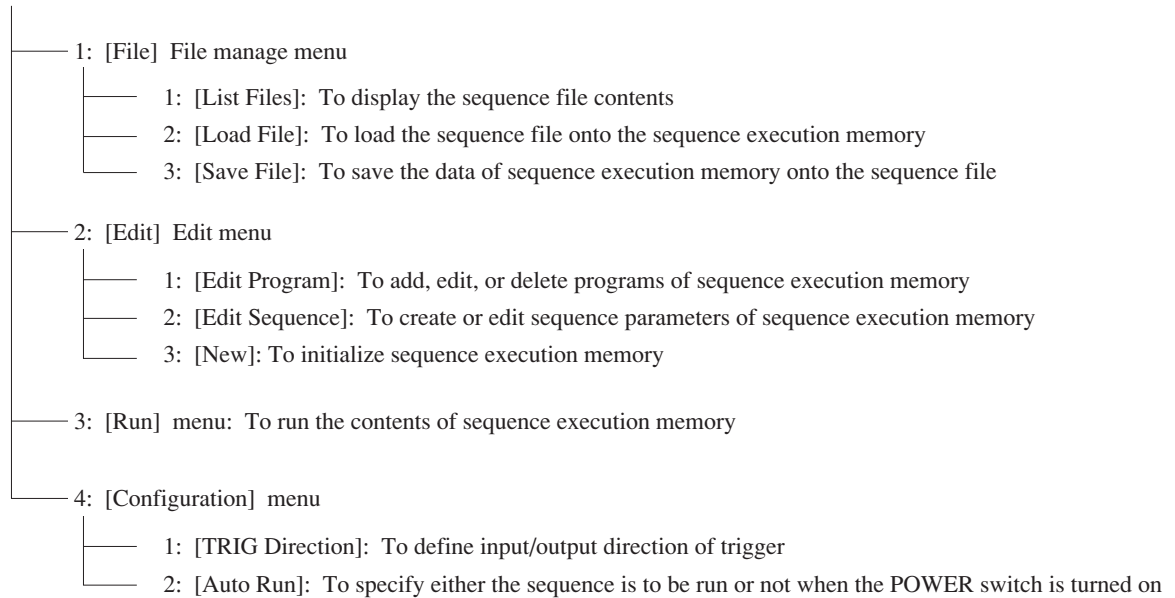

Conceptual diagram of sequence operation

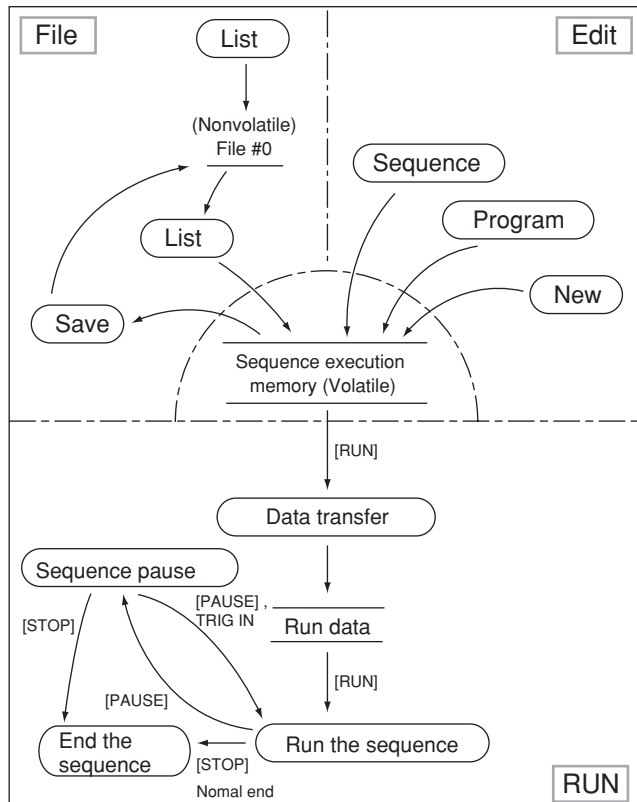

Caution

- When the *POWER* switch is turned on, sequence file #0 (non-volatile memory built-in the power supply) is automatically loaded onto the sequence execution memory.
- The factory-defaults for sequence file #0 are as follows:
Mode : *NVI*
Time unit : *msec*
Step data : *9 steps*

3.4.3 Procedures for Sequence Operation

For sequence operation, it is most recommendable to prepare beforehand a coding data sheet on which data for the required parameters are written. (For coding data sheets, refer to Appendix 5. The examples of coding are for the sequence operation example given in the above.)

The subsequent Items [1] and [2] introduce examples of procedures for entering the data written on a coding sheet into the sequence execution memory.

[1] To create a new sequence execution file

For sequence operation, you must create a sequence execution file first of all. (For the procedure of using an already existing file, refer to [3] "To save or load a file.")

Example of procedure for setting sequence operation parameters and initializing the sequence execution memory

① When the root display is on the LCD, press the [EDIT] key.

```
>1: Edit Program
  2: Edit Sequence
```

(Editing menu)

- The <SEQ> LED will light.
- Items 1 and 2 of the menu items (1 to 3 in all) will appear on the LCD. You can scroll the menu items with the JOG dial or the [▲] [▼] keys.

② Press the [3] key to select [New].

```
Create New Sequence
  Sure ?
```

- A message requesting your confirmation on initializing the sequence execution memory will appear.
- If you press the [ESC] key, the initialize procedure will be aborted and the preceding menu will resume.

③ Press the [ENTER] key to enter into the initialize mode.

```
Mode:NV
```

- This is for setting the sequence operating mode.
- Select the mode with the JOG dial or [▲] [▼] keys.
- Press the [ENTER] key to enter into the sequence operating mode.

④ Select the [NVI] mode with the JOG dial and press the [ENTER] key.

```
Mode:NVI
Unit:msec
```

- Select a step execution time unit for the [NV], [NI], or [NVI] mode. For the [FV] or [FI] mode, this menu does not appear.
- Select the mode with the [◀] [▶] keys and press the [ENTER] key.

⑤ Select [msec] with the JOG dial and press the [ENTER] key.

```
Mode:NVI
Completed.
```

- Initialize the sequence execution memory.

▼ When about one second has elapsed

```
>3: New
  1: Edit Program
```

- When the initialization is complete, the edit menu will resume.

- ⑥ Press the [ESC] key, and the initial sequence menu will resume.

```
>2: Edit  
3: Run
```

Caution

- *If you initialize the sequence execution memory, the existing sequence file will be erased. If you need the existing file for future use, save it. For the save procedure, refer to [3] "To save or load a file."*

[2] To edit sequences and programs

An example of editing a sequence execution file is introduced below.

Example of editing program

① From the edit menu, select [Edit Program] by pressing the [1] key.

```
Program:01 New
000
```

- The figure of the bottom row denotes the total number of the steps in the program.
- You can check the contents of programs Nos. 1 through 16 with the JOG dial or [▲] [▼] keys.

② Press the [ENTER] key.

```
N001
NEW
```

- This message appears as there are no step parameters in the program in this example. When there are step parameters, a program edit menu as shown in Step 6 will appear.

③ Press the [ENTER] key.

```
N001
>1: Modify
```

- 1: Modify -- To modify a program parameter or parameters.
 - 2: Insert -- To insert a program step or steps.
 - 3: Delete -- To delete a program step or steps.
- When editing a new program, you must specify the number of steps for [Insert].

④ Press the [2] key to select [Insert].

```
Insert:001
How many steps? █
```

- Enter the number of steps to be used by the program, with the numeric entry keys.

⑤ Press the [1] key and then the [ENTER] key to secure an area for entry of one step.

```
Insert Steps
Completed.
```

▼ (Program editing display)

```
N001 S 0.0█V S20.00A
... 0001ms
```

- The cursor (█) will blink on the character.
- Entry method
 Numeric value -- Numeric entry keys, [ENTER] key, or JOG dial
 To move on items -- [◀] [▶] keys
 To move on steps -- [▲] [▼] keys

```
N001 S 0.00V S 5.00A
... 0001ms
```

- Setting of S/R for step transition, TRIG, OUT, or PAUSE can be done also by using the [1] or [0] key.

The items shown on the program edit display are as follows:

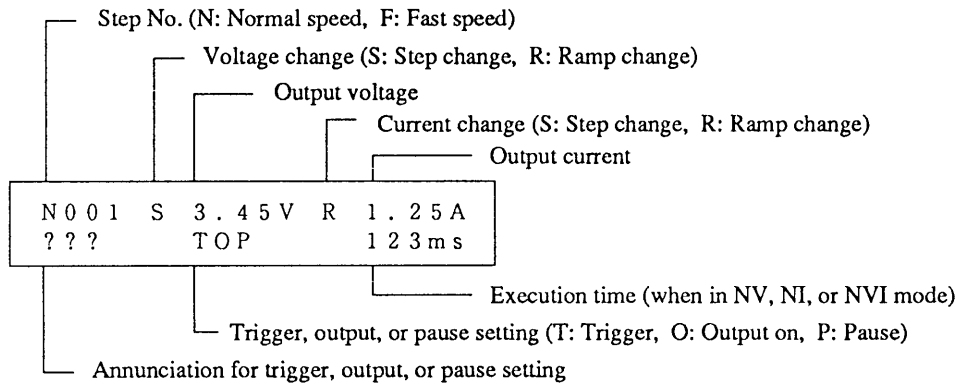

⑥ Press the [ESC] key.

```
N001 S 0.00V S 5.00A
      .0.      0050ms
```

- The cursor disappears from the program edit display.
- When in this state, the steps of the program can be checked with the JOG dial or [▲] [▼] keys. If you specify the step which immediately follows the final step, a message [EOS] (End of Step) will appear.

⑦ Edit other programs also in the same procedure as Steps 1 to 7.

```
N001 R10.00V S 5.00A
      T0.      0010ms
```

- This display example is for setting of Step No. 1 of Program 2.

```
N002 S10.00V S 5.00A
      .0.      0020ms
```

- This display example is for setting of Step No. 2 of Program 2.

```
N003 R16.00V S 5.00A
      .0.      0030ms
```

- This display example is for setting of Step No. 3 of Program 2.

```
N004 R 0.00V S 5.00A
      .0.      0040ms
```

- This display example is for setting of Step No. 4 of Program 2.

```
N001 S 5.00V S 5.00A
      .0.      0030ms
```

- This display example is for setting of Step No. 1 of Program 3.

```
N002 S15.00V S 5.00A
      .0.      0020ms
```

- This display example is for setting of Step No. 2 of Program 3.

```
N003 R 0.00V S 5.00A
      .0.      0050ms
```

- This display example is for setting of Step No. 3 of Program 3.

```
N001 S 0.00V S 5.00A
      ...      0001ms
```

- This display example is for setting of Step No. 1 of Program 16.

⑨ Press the [ESC] key to return to the initial sequence menu.

```
>2: Edit
 3: Run
```

Example of sequence edit

① When the initial sequence menu is on the LCD, press the [EDIT] key and [2] key in this order.

```
S:1 P01 L0001 New
C* E**
```

- You can check the contents of sequences Nos. 1 through 8 with the JOG dial or [▲] [▼] keys.

② Press the ENTER key.

```
S:1 P0█ L0001
C* E**
```

(Sequence editing display)

- Cursor █ will blink on the character.
- Numeric entry: With numeric entry keys and [ENTER] key, or with JOG dial
- Item change: With [◀] [▶] keys
- The asterisk (*) of the end program and that of the chain program indicates that the indicated item is not executed.
- The number of loops "9999" means infinitive repetitions.
- To escape from the edit mode, press the [ESC] key.

```
S:1 P01 L0001
C2 E16
```

③ Changing the sequence numbers, edit sequences by using the [ESC] key, JOG dial, and [ENTER] key.

```
S:2 P02 L0002
C3 E16
```

- The examples of displays shown are for edit of sequences Nos. 2 and 3.
- Sequence No. 2 is to loop the program 2 twice and then chain it to sequence No. 3.
- Sequence No. 3 is to loop the program 3 once and finally execute the first step alone of program 16. There is no chain.

```
S:3 P03 L0001
C* E16
```

The items of the sequence editing display are as follows:

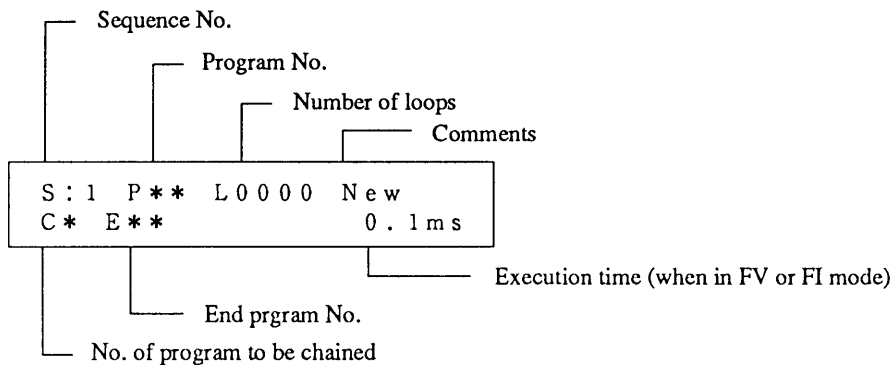

④ Press the [ESC] key twice, and the edit menu will resume.

```
>2: Edit Sequence
3: New Sequence
```

- The sequence editing procedure is complete.

Example of procedure to add or delete steps

① Press the [1] key when the edit menu is on the LCD.

```
Program:01 A
002
```

- The columns following the "A" of the top row are for entry of comments. You can enter comments via GPIB or other external interface.
- The figure on the bottom row indicates the total number of the steps of the program.

② Press the [ENTER] key.

```
N001 S 0.00V S 5.00A
    . . .      0001ms
```

(Program editing display)

- You can check the contents of the steps with the JOG/SHUTTLE dials or [▲] [▼] keys.

③ Press the [ENTER] key.

```
N001 S 0.00V S 5.00A
>1: Modify
```

Select one of the following:

- 1: Modify
- 2: Insert
- 3: Delete

④ Press the [3] key to select [Delete].

```
Delete:001
How many steps? █
```

(To delete steps)

- Enter the number of steps to be deleted, with the numeric entry keys.
- The specified number of steps, starting by the currently displayed step, will be deleted.

⑤ Press the [1] key and then the [ENTER] key to delete the steps.

```
Delete Step
Completed.
```

▼ When about one second has elapsed

```
N001 S 0.00V S 5.00A
    .0.      0001ms
```

- In this example, step 1 has been deleted and step 2 has become step 1.

⑥ Press the [ESC], [ENTER], and [2] keys to select [Insert].

```
Insert:001
How many steps? █
```

(To insert steps)

⑦ Press the [2] key and then the [ENTER] key.

Insert Step
Completed.

- Specify the number of steps to be inserted (two in this example).



N001 S 0.0 V S 5.00A
 .0. 0001ms

- In this example, two steps have been inserted.
- Data of steps to be inserted is undefined yet.
- After the [Insert] mode is over, the [Modify] mode will resume.

NOTE

- Repeating the above procedure, enter the sequences and programs as written on the coding sheets.
- After the entry is over, check the contents of entry by using the sequence display menu and program display menu.
- You may directly call out the edit menu by pressing the [EDIT] key when the root display is on the LCD.

[3] To save or load a file

The sequence execution memory is volatile and its contents are lost if you turn OFF the POWER switch of the power supply. To keep the memory contents (sequence files), you must store them in the nonvolatile memory of the power supply or on a memory card. This section gives examples of procedures to save and load the file.

Example of procedure to save a file

① When the initial sequence menu is displayed, press the **[1]** key and then the **[3]** key.

```
Save:000
NVI Step:0002
```

- Specify the file number of the file to be saved, with the JOG dial or **[▲]** **[▼]** keys.
- The bottom row shows major information about the file already saved.

② Press the **[ENTER]** key.

```
Save:000
Completed.
```

- The sequence operation file has been saved.



```
>3: Save File
4:
```

- After the file saving is complete, the file management menu will resume.

Example of procedure to load a file

① When the file management menu is displayed, press the **【2】** key.

```
Load:000
NVI Step:0002
```

- Specify the file number of the file to be loaded, with the JOG dial or **【▲】** **【▼】** keys.
- The bottom row shows major information about the saved file.

② Press the [ENTER] key.

```
Load File
Completed.
```

- The sequence operation file has been loaded onto the sequence execution memory.



```
>2: Load File
3: Save File
```

- After the file loading is complete, the file management menu will resume.

[4] Setting of Trigger and Auto-run

This section introduces the procedures for setting a trigger direction and the auto-run mode of sequence operation.

Example of procedure for trigger input/output setting

① When the initial sequence menu is displayed, press the [4] key and then the [1] key.

```
>1: TRIG Direction
>1:<In>
```

- Select the required item with the JOG dial and [▲] [▼] keys.

② Press the [▲] key and [ENTER] key. (Instead, you may directly select the item by pressing the key corresponding to the item number.)

```
Trigger Direction
Out
```

- In this example, the trigger in the output direction is selected.

▼ When about one second has elapsed

```
>1: TRIG Direction
2: Auto Run
```

- After the setting is over, the configuration menu will resume.

③ Press the [ESC] key.

```
>4: Configuration
1: File
```

- The initial sequence menu will resume.

NOTE

- If you set the [TRIG Direction] to [OUT], the trigger setting in the step is enabled and the power supply will deliver a trigger output signal through the TRIG I/O terminal of the front sub-panel.
- If you set the [TRIG Direction] to [IN], triggering with an external signal applied through the TRIG I/O terminal of the front sub-panel for terminating the PAUSE state is enabled.
- The Trigger OUT function is applicable to all of the [NV], [NI], [NVI], [FV], and [FI] modes. The Trigger IN function is applicable only to the [NV], [NI], and [NVI] modes.

Example of setting procedure for auto-run

The auto-run function is such that, when the POWER switch is turned on, the power supply automatically executes the sequence #01.

- ① When the initial sequence menu is displayed, press the [4] key and then the [2] key.

```
>2: Auto Run
>1:<OFF>
```

- Select the required item with the JOG dial and [▲] [▼] keys.

- ② Press the [▲] key and then the [ENTER] key. (Instead, you may directly select the item by pressing the key corresponding to the item number.)

```
Auto Run
ON
```

▼ When about one second has elapsed

```
>2: Auto Run
1: TRIG Direction
```

- After the setting is over, the configuration menu will resume.

- ③ Press the [ESC] key.

```
>1: File
2: Edit
```

- The initial sequence menu will resume.

NOTE

- *Be careful when using the Auto Run function. Although it is a very convenient function, it involves a danger. Should you inadvertently turn ON the POWER switch by forgetting that the power supply has been set to the Auto Run, the power supply will immediately deliver its output.*
- *Even when the [Auto Run] function has been set to [ON], the function can be disabled by pressing the [SHIFT] + [ENTER] keys when the initial power-on display is shown on the LCD.*

[5] Run, end, and pause of sequences and programs

Example of procedure for program run

① As you press the [RUN] key when the program number is displayed, the program will be executed once. Press the [EDIT] key and then the [1] key in this order.

```
Program:01 A
002
```

(Program number display)

- Specify a program number with the JOG dial or [▲] [▼] keys.

② Press the [RUN] key.

```
OUT 0.000V 0.00A
RU S1,P01,L0002 2
```

(Display during sequence operation)

Caution

- When in the [NV], [NI], or [NVI] mode, operation proceeds with the time parameter specified in the step; when in the [FV] or [FI] mode, the execution time unit is automatically fixed at approximately 100ms per program.

Example of procedure for sequence run

An example of procedure for running a sequence operation is shown below.

① When the initial sequence menu is displayed, press the [3] key.

```
S:1 P01 L0001
C2 E16
```

(Run menu)

- Specify the sequence number of the sequence to be executed, with the JOG dial or [▲] [▼] keys.
- Instead of the above, you may directly call out the run menu by pressing the [RUN] key when the root display is on the LCD.

② Press the [RUN] key.

```
OUT 0.000V 0.00A
RU S1,P01,L0002 2
```

(Display during sequence operation)

- Instead, you may directly specify the sequence number with the numeric entry keys.

To pause the sequence operation, press the [PAUSE] key.

```
OUT 0.000V 0.00A
PA S1,P01,L0002 3
```

(Display of paused sequence operation)

- The [FV] and [FI] modes of operation cannot be paused.

To resume the sequence operation, press the [PAUSE] key again.

```
OUT  0.000V  0.00A
RU S1,P01,L0002,0002
```

(Display during sequence operation)

To stop the sequence operation forcibly, press the [STOP] key.

```
S:1 P01 L0001
C2 E16
```

(Run menu)

- The forcible stop is effective even when in pause.

NOTE

- The power supply asynchronously accepts the command given from the [PAUSE] key. When it is released from the pause state, it advances to the next step after executing the function for the remaining period of the currently executing step.
- You can call out the run menu by pressing the [RUN] key when the root display is on the LCD.

Caution

- During the sequence operation, the software OVP level and software OCP level which existed immediately before entering the sequence operation remain effective.

The items displayed during the sequence operation are as follows:

```
OUT  0.000V  0.00A
PA S1,P01,L0002,0003
```

The top row indicates the readback values.

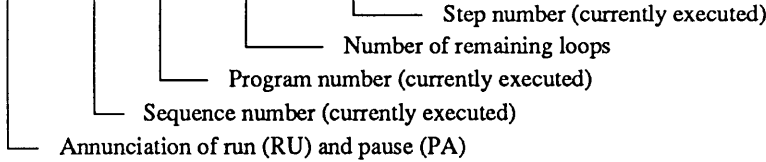

3.5 Application Operation

3.5.1 Configuration

The parameters and other selectable items of operation of the power supply can be configured to best suit the purpose and conditions of use of the power supply. The established configuration can be saved in the non-volatile memory of the power supply and be loaded when the POWER switch is turned on.

As you press the **【SHIFT】** + **【0】** CONFIG keys, the configuration menu will appear. The menu allows you to enter the various settings and selections.

For the [Calibration] which appears as one of the selectable items on the configuration menu, refer to Section 6.2 "Calibration."

Structure and Functions of Configuration Menu

Configuration Menu

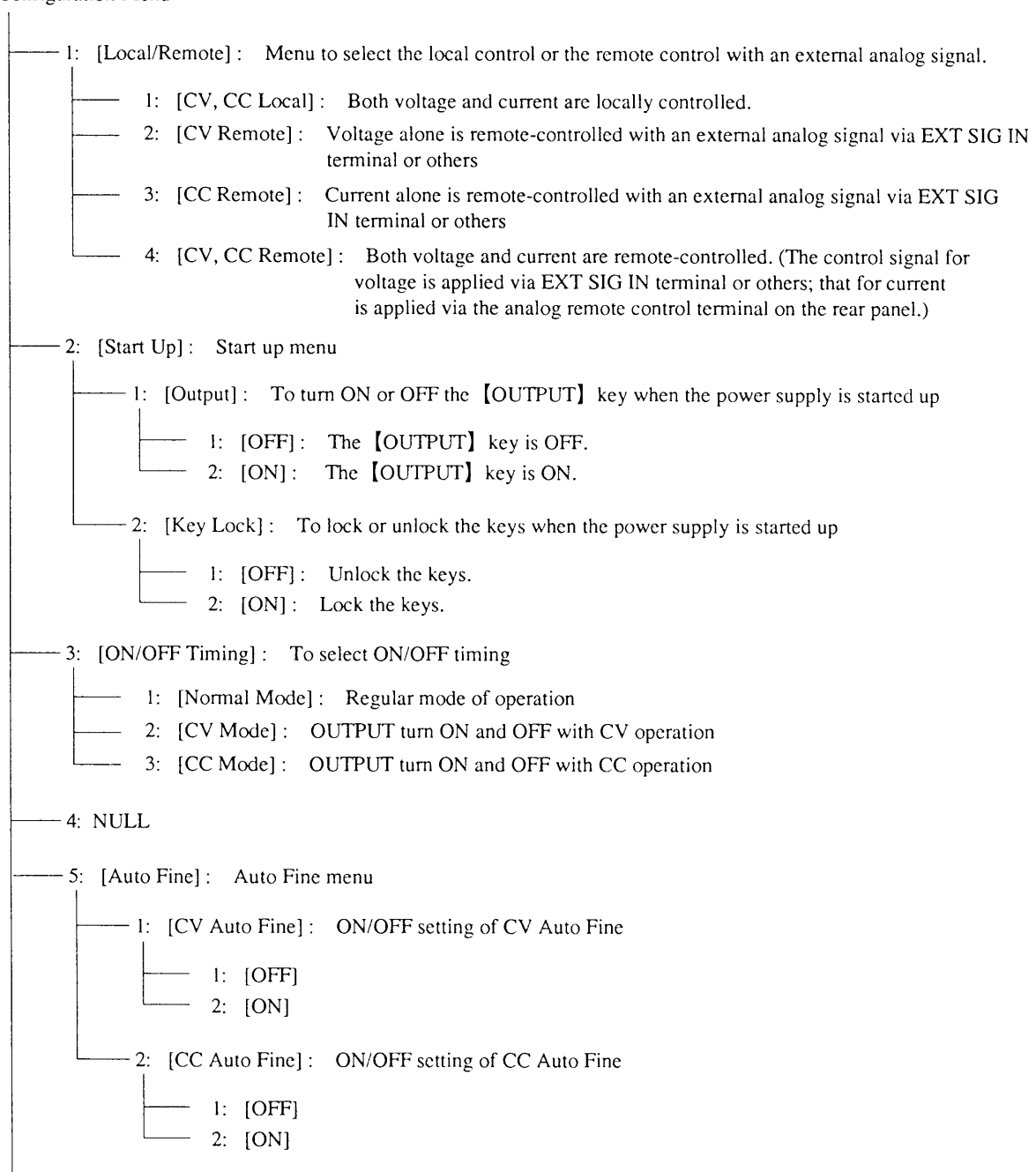

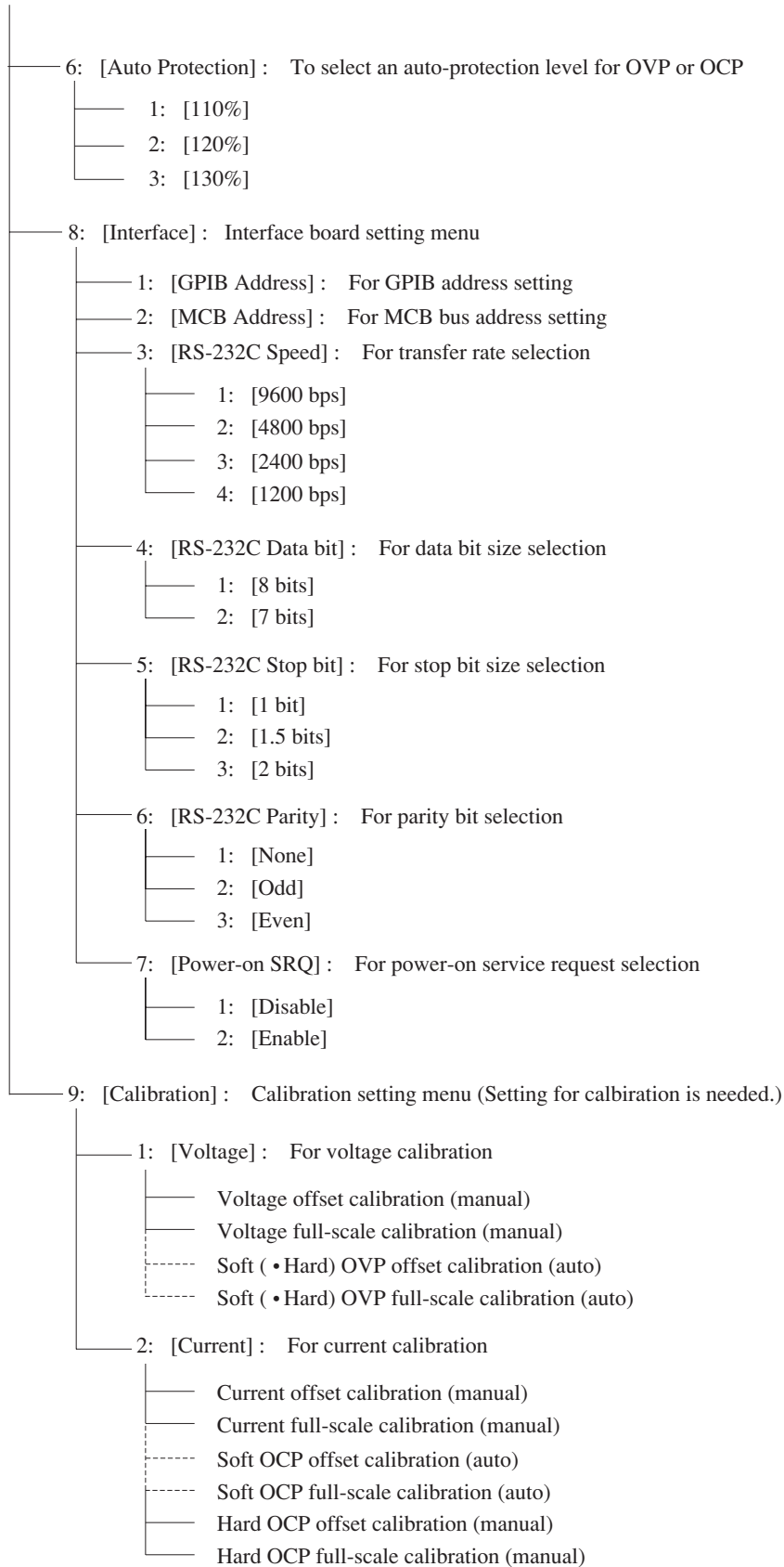

[1] Remote control with an External Analog Signal

The output voltage or current of the power supply can be remote-controlled with an external analog signal (a voltage signal of 0 to approximately 10V or a resistance signal of 0 to approximately 10kΩ).

Example of procedure for remote control with an external analog signal

① Make certain that the output is OFF. Press the **[SHIFT]** + **[0]** CONFIG keys.

```
>1: Local/Remote
  2: Start Up
```

(Configuration menu)

- Items 1 and 2 among the configuration menu items 1 through 9 will appear.

② Press the **[1]** key to select [Local/Remote].

```
>1: Local/Remote
  >1:<CV,CC Local>
```

(Controlled item select menu)

- The item enclosed in <> is the currently selected item.

③ Press the **[2]** key to select [CV Remote].

```
Ext. Local/Remote
  CV Remote
```

- The CV remote control mode has been selected.

▼ When about one second has elapsed

```
>1: Local/Remote
  2: Start Up
```

- The configuration menu will resume.

④ Press the **[ESC]** key.

```
OUT    0.000V    0.00A
```

- The root display will resume.

NOTE

- If you are not going to use the remote control with an external analog signal, select [CV, CC Local].
- To remote-control the output voltage with an external voltage signal when in the [CV Remote] mode, apply the signal via the EXT SIG IN terminal on the front sub-panel or the analog remote control terminal (J2) on the rear panel.
- To remote-control the output current with an external voltage signal when in the [CC Remote] mode, apply the signal via the EXT SIG IN terminal on the front sub-panel or the analog remote control terminal (J2) on the rear panel.
- To remote-control the output voltage and current with external analog signals when in the [CV, CC Remote] mode, connect the voltage-controlling signal via the EXT SIG IN terminal on the front sub-panel or the analog remote control terminal (J2) on the rear panel and connect the current-controlling signal via the analog remote control terminal (J2) on the rear panel.
- Even when in the remote control mode with external analog control signals, you can locally set the output voltage and current from the front panel.
- For the requirements of the external analog control signals and their connection methods, Refer to Section 3.5.2 "Analog Remote Control" and Chapter 7.

Caution

- Do not apply simultaneously the external analog control signals via the EXT SIG IN terminal on the front sub-panel and the analog remote control terminal (J2) on the rear panel (although you may connect the cables for them at the same time).
- At the instant the remote control with an external analog signal is selected, the local settings of voltage and current from the front panel automatically becomes 0V and 0A (although you can locally control them thereafter).
- You cannot select the remote control with an external analog signal when the output is ON.

Example of procedure to display the remote-controlled value

You can monitor the remote-controlled value by pressing the [SHIFT]+[2] keys when the root display is on the LCD.

- ① Press the [OUTPUT] key to turn ON the output.

```
OUT  35.000V  1.00A
```

- ② Press the [SHIFT]+[2] keys.

```
PRE  34.9 V   2.3 A
```

- The sum of the output voltage/current by local control from the front panel plus that by remote control via the analog remote control terminal (J2) on the rear panel is displayed. (That by remote control via the EXT SIG IN terminal on the front sub-panel is not added.)

NOTE

- This display disappears as you press any other key or keys than the [OUTPUT], [SHIFT]+[1]KEYLOCK keys.

Caution

- When this display is on the LCD, the output voltage and current are not displayed.
- The value remote-controlled with an external analog signal cannot be calibrated by the power supply and it is displayed only as a value obtained by conversion with reference to the specified input. Use it only as a reference value.

[2] Setting of Power-on parameters

This section describes the setting procedures of parameters and other items the power supply must assume when its POWER switch is turned on.

OUTPUT SW

To specify the condition of the output switch when the power supply is at power-on.

[ON Disable] -- The output is OFF when at power-on.

[ON Enable] -- The output is ON when at power-on.

- The factory-default is [ON Disable].

KEYLOCK

To specify either the keys are to be locked or not when the power supply is at power-on. Even when the power supply has been started with KEYLOCK, the keys can be released by pressing again the **[SHIFT]** + **[1]** KEYLOCK keys.

- The factory-default is [UNLOCK].

Example of procedure for power-on settings

① (Press the **[OUTPUT]** key, as required.)

Then, press the **[SHIFT]** + **[0]** CONFIG keys and then the **[2]** key in this order.

```
>1: Output
  2: Key Lock
```

(Start up menu)

- Items 1 and 2 among all menu items 1 through 3 are displayed.

② Press the **[1]** key to select [Output].

```
>1:Output
  >1:<Off>
```

- The item enclosed in <> is the currently selected item.

③ Press the **[2]** key to select [On].

```
Power-on Output
  On
```

▼ When about one second has elapsed

```
>1:Output
  2:Key Lock
```

- After the setting is over, the start up menu will resume.
- The power supply hereafter will operate with [Output ON] when at power-on.

④ Press the **[ESC]** key twice.

```
OUT    0.000V    0.00A
```

- The root display will resume.

Caution

- *Be careful when using the Power-on Output function. Although it is a very convenient function, it involves a danger. Should you inadvertently turned ON the POWER switch forgetting that the power supply has been set to Power-on Output, the power supply will immediately deliver its output.*
 - *Even when the Power-on [Output] function has been set to [on], the function can be disabled by pressing the [SHIFT] + [ENTER] keys when the initial power-on display is shown on the LCD.*
- In a similar procedure as above, you can set the [Key Lock] function shown in the start up menu.

[3] Setting of CV/CC ON/OFF timing

Setting of output ON/OFF timing is necessary to prevent undesirable switchover of operation modes when the voltage (or current) rises up or falls down. This is especially true from the viewpoint of maintaining the quality of the waveform when the rise up or fall down is rapid.

- 1: [Normal Mode]Regular mode for regular operation
- 2: [CV Mode]For output turn-on/off in CV mode
- 3: [CC Mode]For output turn-on/off in CC mode

NOTE • The [CV Mode] and [CC Mode] are suitable for a resistive loads. When the load is not resistive, select the [Normal Mode].

- The factory-default is [Normal Mode].

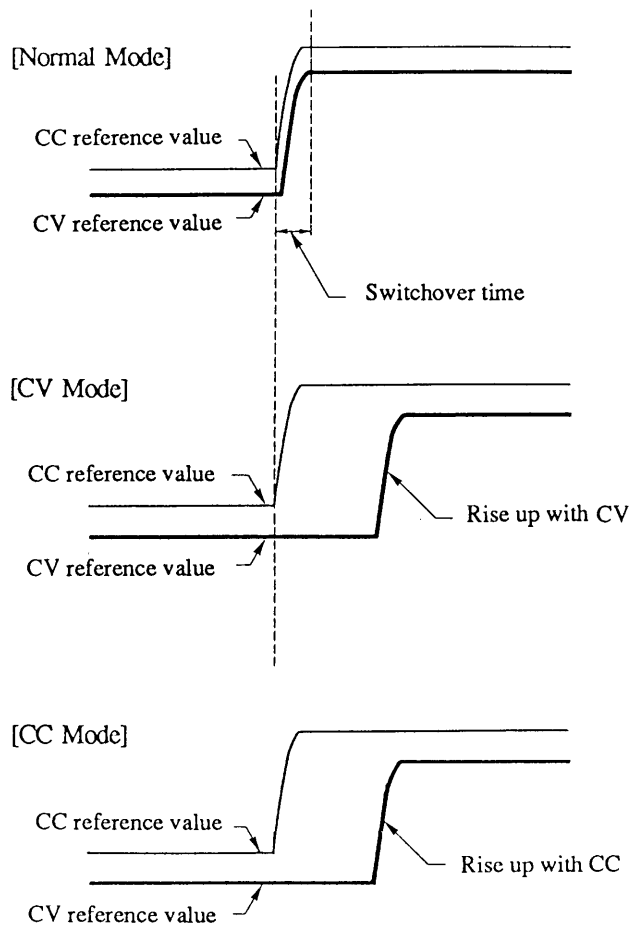

Example of procedure for setting of output ON/OFF timing

- ① Press the **[SHIFT]** + **[0]** CONFIG and **[3]** keys in this order.
(ON/OFF timing menu)

```
>3: ON/OFF Timing
>1:<Normal Mode>
```

- ② Press the **[2]** key to select the [CV Mode].

```
ON/OFF Timing
CV Mode
```

▼ When about one second has elapsed

```
>3:ON/OFF Timing
4:
```

- The ON/OFF timing menu will resume after the setting is over.

- ③ Press the **[ESC]** key.

```
OUT 0.000V 0.00A
```

- The root display will resume.

[4] Setting of Auto Fine

Auto Fine function is to automatically adjust the output to let it conform with the 1mV order of voltage setting or 1mA order of current setting.

Example of procedure for setting of Auto Fine

- ① Press the **[SHIFT]** + **[0]** CONFIG, and **[5]** keys in this order.
(Auto Fine menu)

```
>1: CV Auto Fine
2: CC Auto Fine
```

- ② Press the **[1]** key.

```
>1: CV Auto Fine
>1: <OFF>
```

- ③ Press the **[2]** key to select the [ON].

```
CV Auto Fine
ON
```

▼ When about one second has elapsed

```
>1: CV  Auto Fine  
2: CC  Auto Fine
```

- After the formatting is over, the configuration menu will resume.

③ Press the **【ESC】** key twice.

```
OUT  0.000V  0.00A
```

- The root display will resume.

NOTE

- *When in the Auto Fine mode, software inside the instrument searches for values to make the actual voltage and current shown on the top row of the display are made equal with the set values. Due to this, a certain time (1.5 seconds maximum) is needed before the output voltage and current are settled at the set values.*

[5] Setting of auto-protect level in percentage

This section describes the setting procedure of an auto-protect level in terms of percentage for software OVP and software OCP. You can select 110%, 120%, or 130% of the voltage or current which existed immediately before setting the auto-protect level.

Example of procedure for setting an auto-protect level

- ① Press the **[SHIFT]** + **[0]** CONFIG keys and then the **[6]** key in this order.

```
>6: Auto Protection
>1:<110%>
```

(Auto-protect menu)

- ② Press **[2]** to select [120%].

```
Auto Protection
120%
```

▼ When about one second has elapsed

```
>6: Auto Protection
7:
```

- After the setting is complete, the configuration menu will resume.

- ③ Press the **[ESC]** key.

```
OUT    0.000V    0.00A
```

- The root display will resume.

NOTE

- The auto-protect level can be set in terms of percentage of the voltage or current which has been set as V SET or I SET. The allowable setting ranges of software OVP or software OCP is from 10% to 110% of the rated output voltage or rated output current, respectively.
- If you attempt to set for the auto-protect limit value a value greater than 110% or less than 10% of the rated output voltage or current, the power supply will automatically set it at 110% or 10%, respectively.
- The factory-default for the auto-protect level is [110%].

[6] Setting the operation parameters for interface boards

This section describes the setting procedure of operation parameters of interface boards for GPIB, RS-232C, or MCB (multi-channel bus). When using an interface board through which to control the power supply, you must set an address for the board.

Caution

- When you have changed any of the parameters, be sure to turn OFF once the POWER switch and then turn it on again.

Example of procedure to set operation parameters of GPIB interface board

- ① Press the **[SHIFT]** + **[0]** CONFIG keys and then the **[8]** key in this order.

```
>1: GPIB Address
  2: MCB Address
```

(Interface board parameter setting menu)

- ② Press the **[1]** key to select [GPIB Address].

```
GPIB Address
      01
```

- The bottom row shows the currently ADDRESS 01 existing address number.

- ③ Type a new address number with the numeric entry keys and then press the **[ENTER]** key.

```
GPIB Address
      03
```

- In this example, the address number is set to 3.

- ④ Press the **[ESC]** key twice.

```
OUT   0.000V   0.00A
```

- The root display will resume.

NOTE

- For an RS-232C or MCB interface board also, specify an address number in the same procedure as above.
- For the factory-default for address setting, refer to Chapter 4 "REMOTE PROGRAMMING."

3.5.2 Analog Remote Control

[1] Analog Remote Control Terminal (J2)

The analog remote control terminal (J2) on the rear panel is for remote-control of the power supply with an external analog signal. To remote-control the output voltage or current with the signal applied via the terminal, you must select the corresponding mode on the configuration menu. (Refer to Section 3.5.1 "Configuration.")

Terminal J2 is a 26-pin plug of MIL type. Its pin assignment is as shown on the below table. When using it, insert the pins (supplied) in the terminal cover which is attached to the terminal.

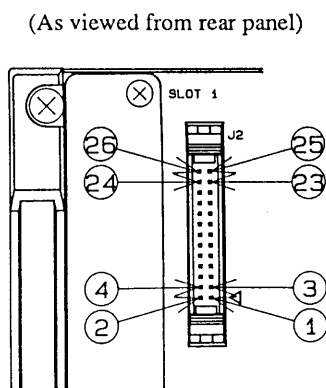

Pin Assignment of Analog Remote Control Terminal (J2)

Pin No.	Signal	Pin No.	Signal
②⑥	CURRENT SOURCE 2 (1mA)	②⑤	+REFERENCE
②④	ANALOG COMMON *	②③	CV EXT VOLTAGE CONTROL *
②②	NO CONNECTION	②①	-REFERENCE
②①	CURRENT SOURCE 1 (1mA)	②①	+REFERENCE
②⑧	ANALOG COMMON *	②⑦	CC EXT VOLTAGE CONTROL *
②⑥	NO CONNECTION	②⑤	-REFERENCE
②④	NO CONNECTION	②③	CV MONITOR *
②②	ANALOG COMMON *	②①	ANALOG COMMON *
②①	OUTPUT ON/OFF [¯]	②①	CC MONITOR *
②⑧	CV MODE SIGNAL	②⑦	POWER OFF [¯]
②⑥	CC MODE SIGNAL	②⑤	OPTION
②④	OUTPUT ON SIGNAL	②③	DIGITAL COMMON
②②	ALARM SIGNAL	②①	SIGNAL COMMON

* See the **Caution** below.

Caution

- The analog common line is connected to -S. The common line of the monitor output and that of the control voltage signal are connected to the analog common line. Pay attention to this when grounding the output or other line.
- Before making connection to the analog remote control terminal, be certain that the POWER switch is OFF.

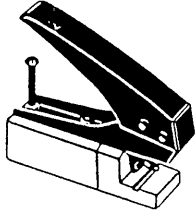
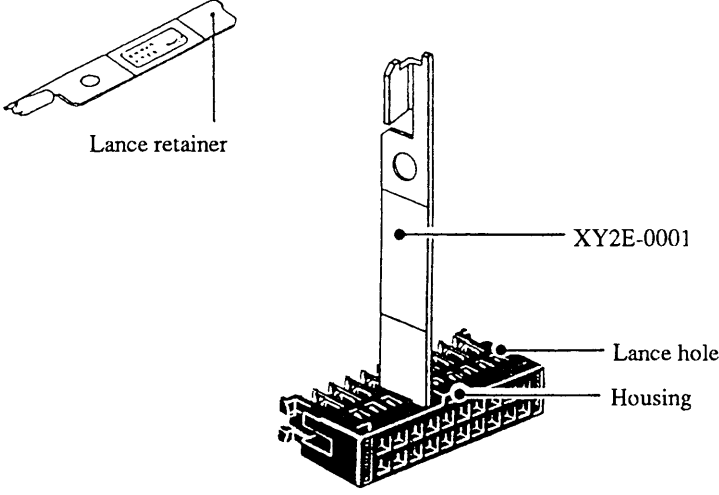
Tools for crimping terminals	Tool remarks
<p>XY2B-7006 Crimping Tool (OMRON Corp.)</p>	<ul style="list-style-type: none"> For the crimping method, refer to the instruction sheet which accompanies the tool. 
<p>XY2E-0001 Contact Remover (OMRON Corp.)</p>	<ul style="list-style-type: none"> Remove the hood cover before using the tool. 

[2] Analog Remote Control of Output Voltage

Output voltage control with an external voltage signal

You can remote-control the output voltage of the power supply with a voltage signal of 0 to approximately 10V. To do this, set the supply to the corresponding mode by selecting it on the configuration menu. (Refer to Section 3.5.1 "Configuration.")

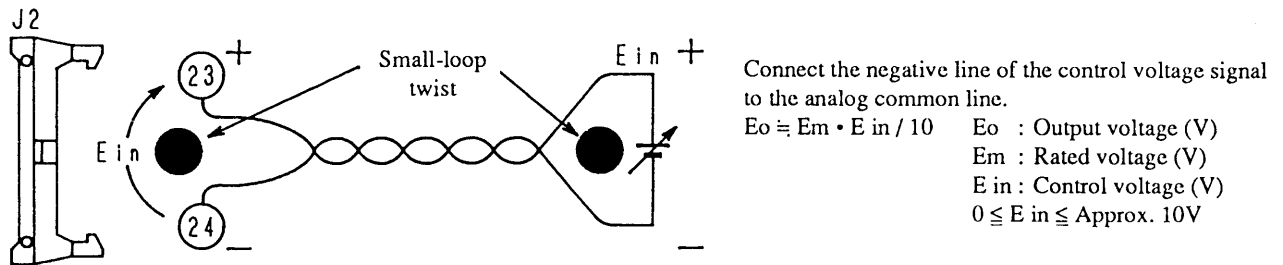

Caution

- The "-" line of E_{in} is connected to the analog common line. The analog common line is connected to -S. For the sake of safety, use for E_{in} a voltage source which is isolated from the casing of the power supply. (If it is connected to other potential, it may cause damage to the control circuit of the power supply.)

NOTE

- The output voltage is the sum of the voltage corresponding to the signal applied via the analog remote control terminal plus the voltage set locally from the front panel or remotely via the GPIB, RS-232C, or MCB interface. For example, assuming that the rated voltage of the power supply is 35V, if $E_{in}=1V$ is applied via the terminal, a voltage of approximately 3.5V will be added to the locally-set voltage. If the locally-set voltage is 10V, the output voltage (E_o) will be 13.5V.
- The input impedance between pins ②③ and ②④ of the analog remote control terminal is $1M\Omega$.
- For the control voltage signal (E_{in}), use a quality and stable voltage of less noise.
- When the external control voltage (E_{in}) circuit is made open, a noise of approximately 0.5% of the rated voltage will be superimposed on the output voltage.

Output voltage control with an external resistance signal - Type 1 (by using a 2-terminal variable resistor)

You can remote-control the output voltage of the power supply with a resistance signal. The output voltage (E_o) will be directly proportional to the resistance input (R_{in}). To do this, set the power supply to the corresponding mode by selecting it on the configuration menu. (Refer to Section 3.5.1 "Configuration.")

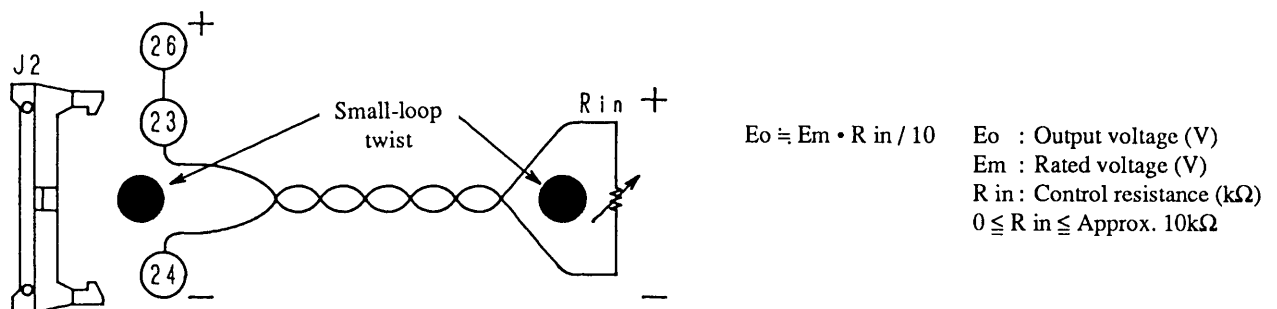

Caution

- If the resistance input (R_{in}) circuit is made open, the power supply will deliver its rated output voltage.

NOTE

- The output voltage is the sum of the voltage corresponding to the signal applied via the analog remote control terminal plus the voltage set locally from the front panel or remotely via the GPIB, RS-232C, or MCB interface. For example, assuming that the rated voltage of the power supply is 35V, if $R_{in}=1k\Omega$ is applied via the terminal, a voltage of approximately 3.5V will be added to the locally-set voltage. If the locally-set voltage is 10V, the output voltage (E_o) will be 13.5V.
- A current of approximately 1mA will constantly flow through resistor R_{in} .
- For resistor R_{in} , use a metallic film resistor or a wire wound resistor of 1/2W or more. The resistor should be a quality one, with good stability against temperature change and aging.

Output voltage control with an external resistance signal - Type 2 (by using a 3-terminal variable resistor)

You can remote-control the output voltage of the power supply with a resistance signal. The output voltage (E_o) will be directly proportional to the resistance input (R_{in}). Type 2 allows you to adjust the output voltage offset and maximum value.

For this mode of operation, set the power supply to the corresponding mode by selecting it on the configuration menu. (Refer to Section 3.5.1 "Configuration.")

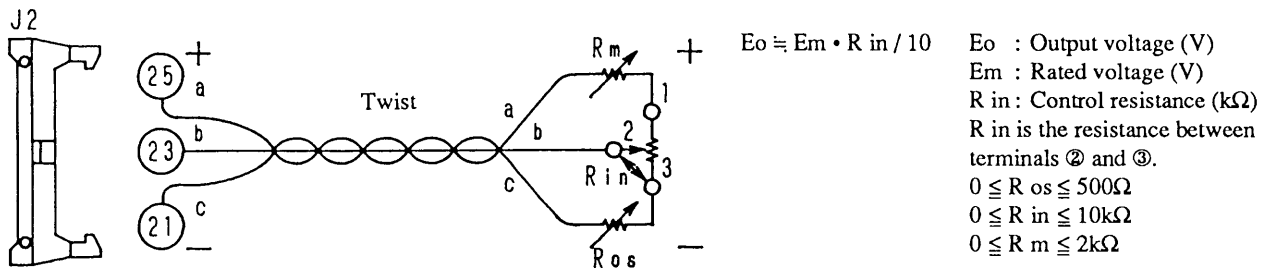
**NOTE**

- The output will increase as you turn R_{in} in the direction shown by the arrowhead. When $R_{in}=0$, adjust the offset of output E_o with R_{os} . Next, when R_{in} is its maximum (approx. $10k\Omega$), adjust the maximum voltage with R_m . The setup will operate even when R_{os} and R_m are not used. When they are not used, however, the output voltage of the power supply whose rated output voltage is 16V will become approximately -0.3V to 18.7V and that of the power supply whose rated output voltage is 35V will become approximately -0.5V to 41V. Since the maximum value acceptable by the OVP is 110% (17.6V or 38.5V) of the rated output voltage, the OVP will trip if you turn R_{in} to its maximum position.
- The output voltage is the sum of the voltage corresponding to the signal applied via the analog remote control terminal plus the voltage set locally from the front panel or remotely via the GPIB, RS-232C, or MCB interface. For example, assuming that the rated voltage of the power supply is 35V, if $R_{in}=1k\Omega$ is applied via the terminal, a voltage of approximately 3.5V will be added to the locally-set voltage. If the locally-set voltage is 10V, the output voltage (E_o) will be 13.5V.
- A current of approximately 1mA will constantly flow through resistors R_{in} , R_{os} , and R_m .
- For resistors R_{in} , R_{os} , and R_m , use metallic film resistors or wire wound resistors of 1/2W or more. The resistors should be quality ones, with good stability against temperature change and aging.

[3] Analog Remote Control of Output Current

Output current control with an external voltage signal

You can remote-control the output current of the power supply with a voltage signal of 0 to approximately 10V. To do this, set the power supply to the corresponding mode by selecting it on the configuration menu. (Refer to Section 3.5.1 "Configuration.")

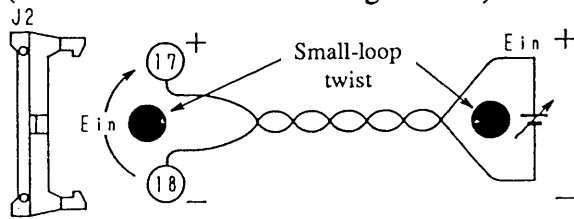

Caution

- The "-" line of E_{in} is connected to the analog common line. The analog common line is connected to -S. For the sake of safety, use for E_{in} a voltage source which is isolated from the casing of the power supply. (If it is connected to other potential, it may cause damage to the control circuit of the power supply.)

Connect the negative line of the control voltage signal to the analog common line.

$$I_o \approx I_m \cdot E_{in} / 10$$

I_o : Output current (A)
 I_m : Rated current (A)
 E_{in} : Control voltage (V)
 $0 \leq E_{in} \leq \text{Approx. } 10\text{V}$

NOTE

- The output current is the sum of the current corresponding to the signal applied via the analog remote control terminal plus the current set locally from the front panel or remotely via the GPIB, RS-232C, or MCB interface. For example, assuming that the rated current of the power supply is 10A, if $E_{in}=1\text{V}$ is applied via the terminal, a current of approximately 1A will be added to the locally-set current. If the locally-set current is 5A, the output current (I_o) will be approximately 6A.
- The input impedance between pins ⑰ and ⑱ of the analog remote control terminal is $1\text{M}\Omega$.
- For the control voltage source (E_{in}), use a quality and stable voltage source with less noise.
- When the external control voltage (E_{in}) circuit is made open, a noise of approximately 0.5% of the rated current will be superimposed on the output current.

Output current control with an external resistance signal - Type 1 (by using a 2-terminal variable resistor)

You can remote-control the output current of the power supply with a resistance signal. The output current (I_o) will be directly proportional to the resistance input (R_{in}). To do this, set the power supply to the corresponding mode by selecting it on the configuration menu. (Refer to Section 3.5.1 "Configuration.")

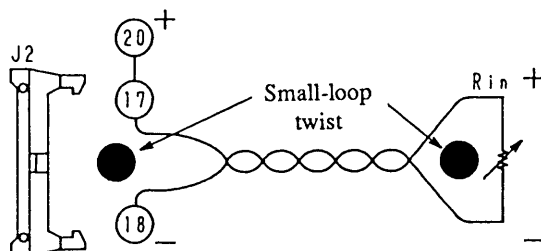

Caution

- If the resistance input (R_{in}) circuit is made open, the power supply will deliver its rated output current.

NOTE

- The output current is the sum of the current corresponding to the signal applied via the analog remote control terminal plus the current set locally from the front panel or remotely via the GPIB, RS-232C, or MCB interface. For example, assuming that the rated current of the power supply is 10A, if $R_{in}=1\text{k}\Omega$ is applied via the terminal, a current of approximately 1A will be added to the locally-set current. If the locally-set current is 5A, the output current (I_o) will be approximately 6A.
- A current of approximately 1mA will constantly flow through resistor R_{in} .
- For resistor R_{in} , use a metallic film resistor or wire wound resistor of 1/2W or more. The resistor should be a quality one, with good stability against temperature change and aging.

$$I_o \approx I_m \cdot R_{in} / 10$$

I_o : Output current (A)
 I_m : Rated current (A)
 R_{in} : Control resistance ($\text{k}\Omega$)
 $0 \leq R_{in} \leq \text{Approx. } 10\text{k}\Omega$

resistor)

You can remote-control the output current of the power supply with a resistance signal. The output current (I_o) will be directly proportional to the resistance input (R_{in}). Type 2 allows you to adjust the output current offset and maximum value.

For this mode of operation, set the power supply to the corresponding mode by selecting it on the configuration menu. (Refer to Section 3.5.1 "Configuration.")

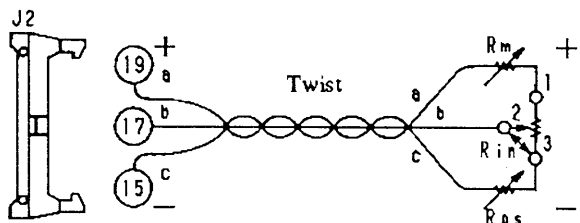

$$I_o \cong I_m \cdot R_{in} / 10$$

I_o : Output current (A)
 I_m : Rated current (A)
 R_{in} : Control resistance (k Ω)
 R_{in} is the resistance between terminals ② and ③.
 $0 \leq R_{os} \leq 500 \Omega$
 $0 \leq R_{in} \leq 10k \Omega$
 $0 \leq R_m \leq 2k \Omega$

NOTE

- The output will increase as you turn R_{in} in the direction shown by the arrowhead. When $R_{in}=0$, adjust the offset of output I_o with R_{os} . Next, when R_{in} is its maximum (approx. 10k Ω), adjust the maximum current with R_m . The setup will operate even when R_{os} and R_m are not used. When they are not used, however, the output current of the power supply will be approximately -2% to 117% of the rated output current. Since the maximum value acceptable by the OCP is 110% of the rated output current, the OCP will trip if you turn R_{in} to its maximum position.
- The output current is the sum of the current corresponding to the signal applied via the analog remote control terminal plus the current set locally from the front panel or remotely via the GPIB, RS-232C, or MCB interface. For example, assuming that the rated current of the power supply is 10A, if $R_{in}=1k\Omega$ is applied via the terminal, a current of approximately 1A will be added to the locally-set current. If the locally-set current is 5A, the output current (I_o) will be approximately 6A.
- A current of approximately 1mA will constantly flow through resistors R_{in} , R_{os} , and R_m .
- For resistors R_{in} , R_{os} , and R_m , use metallic film resistors or wire wound resistors of 1/2W or more. The resistors should be quality ones, with good stability against temperature change and aging.

[4] ON/OFF control of output

The output of the power supply can be ON/OFF-controlled with an external contact signal. When the output is turned OFF by the external contact signal, the OUTPUT LED illuminates.

The output is OFF when the external contact is "Make".

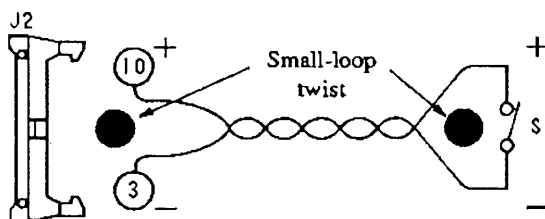

Terminal ⑩ is pulled up to 5V with a 10k Ω resistor within the power supply.

Terminal ③ is of the digital common line. (It is connected to the -S terminal within the power supply.)

NOTE

- The output OFF command has a priority over the output ON action. The output of the power supply is not turned ON unless the output signal fed from the front panel or via the interface board (GPIB, RS-232C, or MCB) and that fed via the analog remote control terminal are both for ON.
- The current that flows through the contact (switch S) is 0.5mA or less. The open-contact voltage is 5V DC.

[5] Turning OFF the POWER switch

The POWER switch of the power supply can be turned OFF with an external contact signal. The POWER switch is OFF when the external contact is "Make".

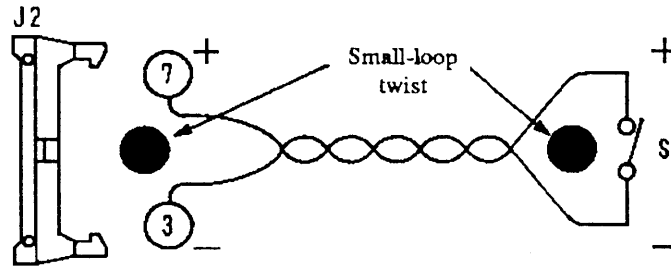

Terminal ⑦ is pulled up to 15V with a 12kΩ resistor within the power supply.

Terminal ③ is of the digital common line. (It is connected to the -S terminal within the power supply.)

NOTE • The current that flows through the contact (switch S) is approximately 1mA. The open-contact voltage is 15V DC.

[6] Voltage monitor and current monitor

Voltage Monitor

The power supply delivers a monitor signal of approximately 0V to approximately 2V to represent the output voltage of 0V to the rated value.

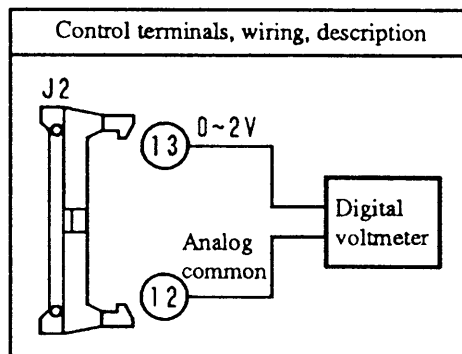

Current Monitor

The supply delivers a monitor signal of approximately 0V to approximately 2V to represent the output current of 0A to the rated value.

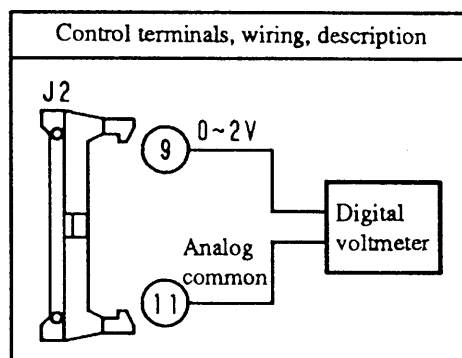

NOTE • The monitor signals do not indicate waveforms.
 • The common line terminals of the monitor signals are terminals ⑪ and ⑫. They are connected to the -S terminal.

[7] Status output signals

The power supply delivers its status signals as mentioned below. The signals are isolated from the power supply by photocouplers.

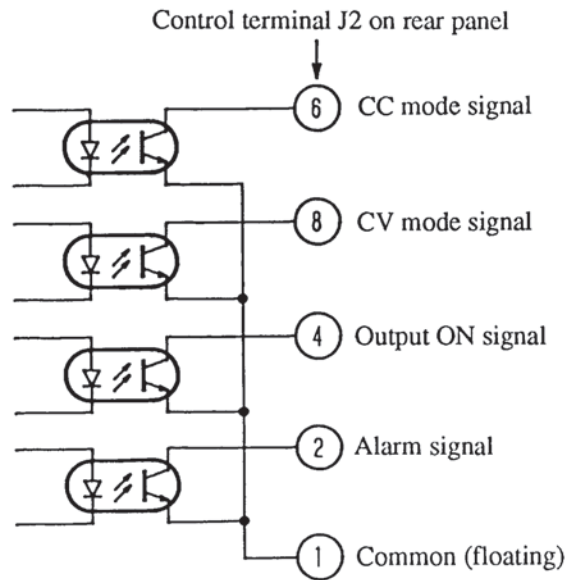

Control terminal J2 on rear panel Pin assignment of analog remote control terminal

- ⑥ CC mode signal ON when power supply is in CC mode
- ⑧ CV mode signal ON when power supply is in CV mode
- ④ Output ON signal ON when the output is ON
- ② Alarm signal ON when OVP or OHP has tripped
- ① Common (floating)

NOTE

- If the OVP trips when the power supply is set to power-OFF or crowbar-ON, the alarm signal is turned ON for only approximately 60ms following the trip.
- The photocouplers are Toshiba TLP521-1 or equivalent.

(Ta = 25)

Item		Symbol	TLP521-1	Unit
Detector side	Collector-emitter voltage	V_{CEO}	55	V
	Emitter-collector voltage	V_{ECO}	7	V
	Collector current	I_c	50	mA
	Collector power dissipation	P_c	150	mW
	Collector power dissipation reduction (Ta=25 up) (per circuit)	$\Delta P_c / ^\circ C$	-1.5	mW/ $^\circ C$
Operating temperature		T_{opr}	-55 to 100	$^\circ C$
Storage temperature		T_{str}	-55 to 125	$^\circ C$
Allowable loss (per circuit)		P_t	250	mW
Allowable loss reduction (Ta=25 up) (per circuit)		$\Delta P_t / ^\circ C$	-2.5	mW/ $^\circ C$
Withstanding voltage (Note 1)		BV_s	2500	Vrms

Note 1: AC, for 1 minute, relative humidity 40% to 60%

Chapter 4

REMOTE

PROGRAMMING

This chapter describes the method to control the power supply remotely from a controller via an interface board (optional).

Contents	Page
4.1 Initial Setting of Interface	4-3
4.1.1 GPIB Interface	4-3
4.1.2 RS-232C Interface	4-4
4.1.3 MCB Interface	4-5
4.2 Programming Format	4-6
4.2.1 Commands	4-6
4.2.2 Response Message	4-7
4.2.3 Acknowledge Message (RS-232C)	4-7
4.2.4 Flow Control (RS-232C)	4-8
4.3 Description of Commands	4-9
4.3.1 Terminology	4-9
4.3.2 Structures of Commands	4-10
4.4 Bit Assignment of Registers	4-25
4.5 Relationships Among SRQ, Status Bytes, and Registers	4-28
4.6 Table of Error Codes	4-29
4.7 Examples of Remote Programming	4-30
4.7.1 Initializing the Interface Board	4-30
4.7.2 Examples of Application Programs	4-31
4.7.3 Table of Command Headers	4-45

You can remote-control the power supply from a personal computer or other controller via an optional interface board (refer to Section 7.4 "Optional Items"). This chapter explains commands that you may use for this type of remote control.

- NOTE** • *For the installation method of the interface board, refer to its operation manual*

Applicable Interface Boards

The remote-control commands introduced in this chapter are applicable to the following three types of interface boards:

- IB11: GPIB Interface Board
- RS11: RS-232C Interface Board
- MC11S: MCB (multi channel bus) Interface Board

- NOTE**
- *As the command for the remote control status is given to the power supply via the interface, the supply becomes the interface status. To return it to the local status, press the [SHIFT] + [BS] LOCAL key.*
 - *For the displays that appear when in the interface status, refer to Section 3.3.7 "Displaying the Interface Status."*

4.1 Initial Setting of Interface

4.1.1 GPIB Interface

[1] Setting the GPIB address

For the setting procedure of the GPIB address, refer to Section 3.5.1 "Configuration."

The factory-default for the GPIB address is "1."

[2] Setting the response message terminator (delimiter)

For the response message terminator, select one of the following:

- CrLf+EOI
- Cr+EOI Cr : Carriage return
- Lf+EOI Lf : Line feed
- EOI EOI : End of identify

The response message terminator can be set by using the **TERM** command. For data transaction between the controller and the IB11, it is necessary that their response message terminators mutually conform. If the terminators do not conform, data transaction between them may be unsuccessful. For the **TERM** command, refer to Section 4.3.2, [10] "System Commands."

The factory-defaults for the response message terminator is CrLf+EOI.

[3] Setting the Power-on SRQ

For the setting method of the Power-on SRQ (service request), refer to Section 3.5.1, "Configuration."

The factory-default for the Power-on SRQ is "Disable."

4.1.2 RS-232C Interface

[1] Setting RS-232C protocols

When you have selected the RS-232C, be sure to set the items mentioned below. For setting of these items, refer to Section 3.5.1 "Configuration." The figures enclosed in the parentheses are factory-defaults.

- Transfer rate (9600 bps)
- Data bit size (8 bit)
- Stop bit size (2 bit)
- Parity bit (none)

[2] Setting the response message terminator (delimiter)

For the response message terminator (delimiter), select one of the following:

- CrLf
- Cr Cr : Carriage return
- Lf Lf : Line feed
- None

The response message terminator can be set by using the **TERM** command. For data transaction between the controller and the RS11, it is necessary that their response message terminators mutually conform. If the terminators do not conform, data transaction between them may be unsuccessful. For the **TERM** command, refer to Section 4.3.2, [10] "System Commands."

The factory-defaults for the response message terminator is CrLf.

[3] Resetting to the local status

The power supply cannot be reset to the local status by a command given via the interface. It must be reset locally from the front panel, by pressing the **[SHIFT] + [BS] LOCAL** keys.

4.1.3 MCB Interface

[1] Setting the MCB device address

When you have selected the MCB, be sure to set the device address for it. For the setting procedure of the MCB device address, refer to Section 3.5.1 "Configuration."

- Caution**
- *Set device addresses as follows.*
Master: 0
Slaves: Any of 1 to 15

[2] Resetting to the local status

The power supply cannot be reset to the local status by a command given via the MCB interface. It must be reset locally from the front panel, by pressing the [SHIFT] + [BS] LOCAL keys.

4.2 Programming Format

This section describes the structure of the general-type programming format.

For convenience of description, the following symbols are used in this chapter.

- : Required characters such as header and data
- [] : Data that may not be required depending on mode
- < > : Pronominal characters
- () : Substitutable characters
- [] : Unit characters
- xxh. : Hexadecimal data

4.2.1 Commands

These are the commands that are fed from the GPIB controller or RS-232C terminal to the power supply.

[1] Program message

This command is to operate the power supply. It consists of a header and data, and is in a form of ASCII strings.

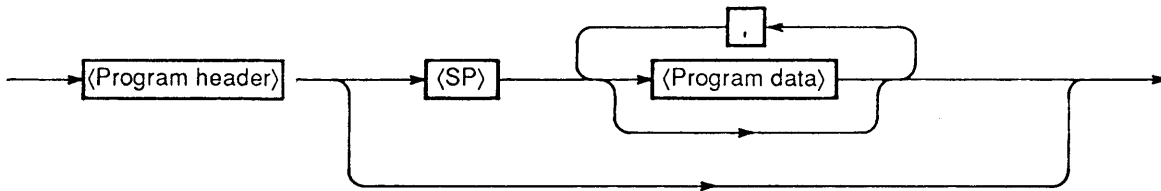

[2] Query message

This command is to obtain information from the power supply. It consists of a header (with a "?") and data, and is in a form of ASCII strings.

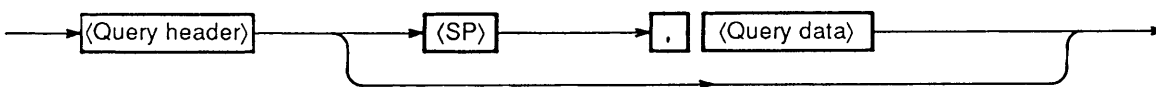

[3] Compound message

This message consists of two or more program messages and a query message.

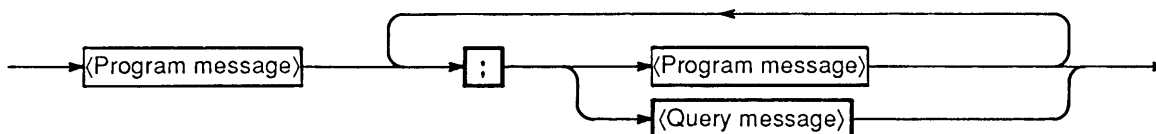

[4] Hold-off (GPIB)

By suffixing a "@"(40h) at the end of a program message or a query message, the GPIB can be held off until the execution of the message is complete. However, in the event of a command message terminator with only EOI, use "@@".

- NOTE**
- *The hold-off function is peculiar to the GPIB interface board (IB11).*

4.2.2 Response Message

The response message is a message returned by the power supply to the GPIB controller or RS-232C terminal, in response to a query message.

The response message consists of a header and data, and is in the form of ASCII strings.

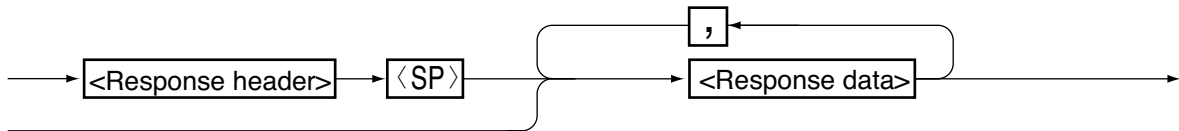

4.2.3 Acknowledge Message (RS-232C)

An acknowledge message corresponding to a program message is sent from the power supply to the RS-232C terminal, notifying that the processing for the program message is complete. The acknowledge message consists only of a header, and is in a form of ASCII strings.

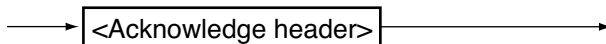

- NOTE**
- *The acknowledge message is peculiar to the RS-232C interface board (RS11).*
 - *There are three types of acknowledge headers as follows:*
 - "OK" Normally ended.*
 - "ERROR" Syntax error or other error occurred.*
 - "TIME OUT" MCB address error, etc.*
 - *The acknowledge message can be turned ON/OFF with the **SILENT** command.*
 - *The factory-default for the acknowledge message is <SILENT ON>.*

4.2.4 Flow Control (RS-232C)

The transmit/receive operation of the RS11 can be controlled with X_{ON}/X_{OFF}. These control codes are DC (device control) codes.

	Action	ISO, EIA Codes
DC1	Request to send	11h
DC3	Request to stop sending	13h

[1] To control transmission from RS-232C terminal to RS11

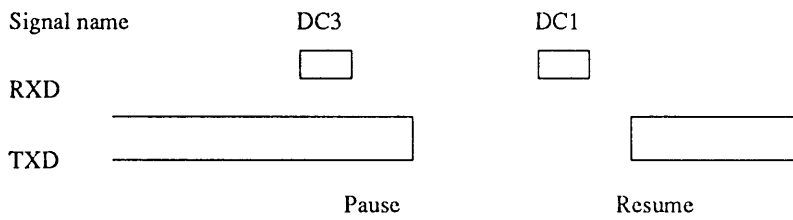

NOTE • The RS11 pauses transmission within 3 characters after receiving DC3.

[2] To control transmission from RS11 to RS-232C terminal

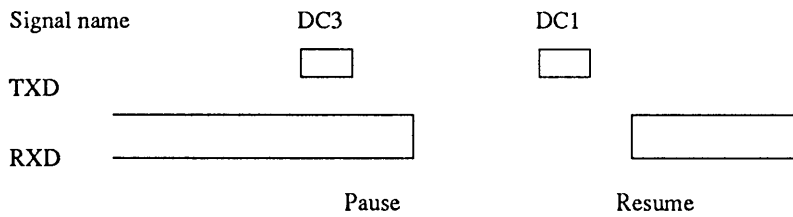

NOTE • The terminal should stop transmission within 10 characters after receiving DC3.

Caution • Transmission/reception must be controlled by means of flow control or acknowledge messages. Communication may not be successful with mere transmission.

4.3 Description of Commands

4.3.1 Terminology

This section explains the terms used in the commands.

[1] Header

The header is a keyword of a command and is composed of a train of ASCII code characters. You may use either uppercase or lowercase letters for headers, although uppercase letters are used throughout in this manual for ease of understanding. You cannot put, however, a space character or the like within a header.

[2] Data

This item is an argument that immediately follows a header. The format of data differs depending on the type of header.

Type of data

NR1	1 (ON) / 0 (OFF)
NR2	Decimal integer
NR3	Hexadecimal
NR4	Real number *Note 1
"string"	Alphanumeric string *Note 2 Must be enclosed in double-quotes ("").
sp	Space code (20h)
?	Character "?" (3Fh)
,	Character "," (2Ch)

**Note 1:* • Accepts integer, fraction, and exponent types.

Examples: 8, 1.25, 2.56E+1

• The following units can be identified.

Voltage: kV, V, mV ([V] for abbreviation)

Current: kA, A, mA ([A] for abbreviation)

Time: s, ms, μ s ([s] for abbreviation)

For programming, use "us" instead of " μ s".

**Note 2:* • The control code must not include a space or spaces.

• Lowercase letters are automatically converted into uppercase letters by the system.

[3] Response messages

All character trains of response headers and response data are with up percase letters of ASCII Codes.

4.3.2 Structures of Commands

[1] Voltage, current, and output control commands (1/2)

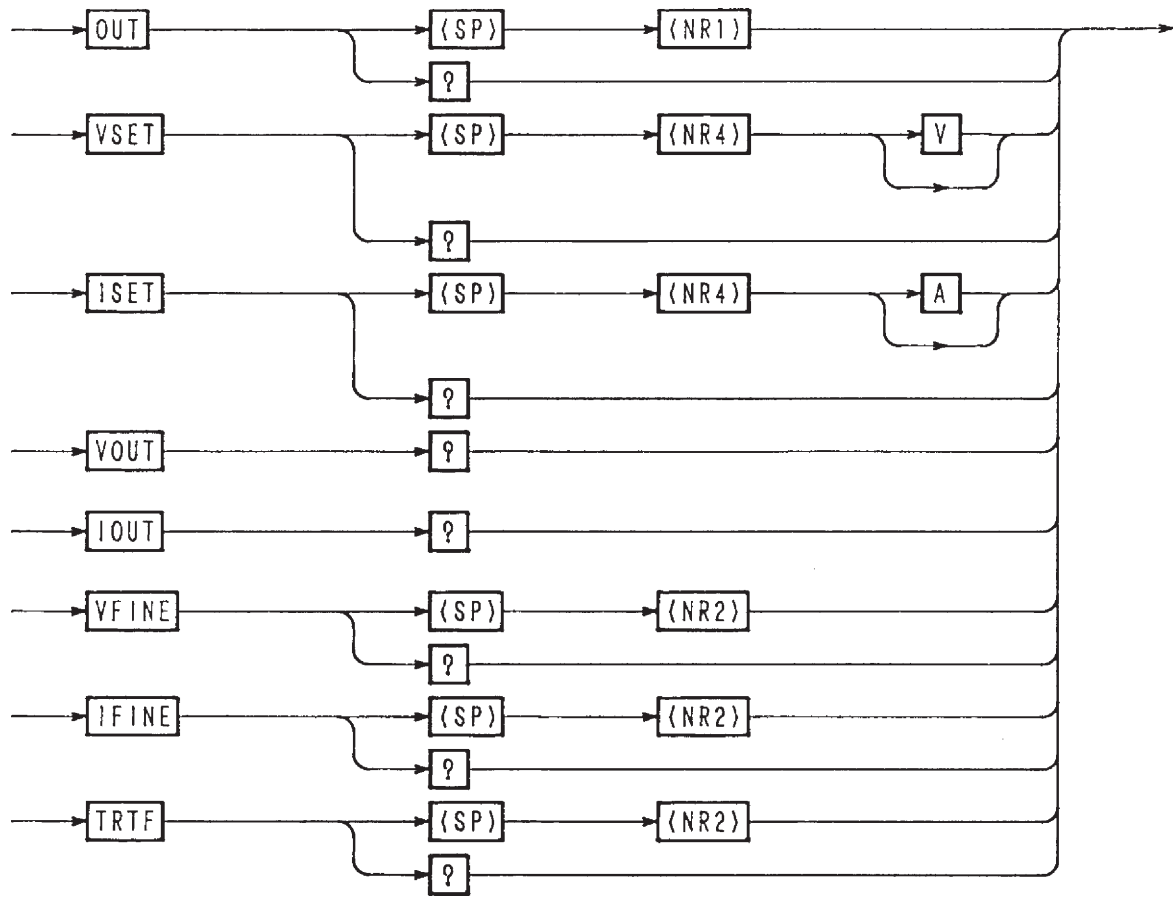

Header	Data	Action	Remarks
OUT	0 (OFF)	Turn OFF the output	
	1 (ON)	Turn ON the output	
OUT?		Return 0 or 1	
VSET	Real number [V]	Set the voltage	
VSET?		Return the set voltage	
ISET	Real number [A]	Set the current	
ISET?		Return the set current	
VOUT?		Return the readback output voltage	
IOUT?		Return the readback output current	
VFINE	-128 to +127	Set the Fine-adjust voltage	
VFINE?		Return the set Fine-adjust voltage	
IFINE	-128 to +127	Set the Fine-adjust current	
IFINE?		Return the set Fine-adjust current	
TRTF	1	Set Tr Tf time to 50 μ s	
	2	Set Tr Tf time to 500 μ s	
	3	Set Tr Tf time to 5ms	
TRTF?		Return the set Tr Tf value	

NOTE

- For the operating procedures, refer to Section 4.7 "Examples of Remote Programming", [1] "Examples of Voltage Settings and Monitor Readback".

[2] Voltage, current, and output control commands (2/2)

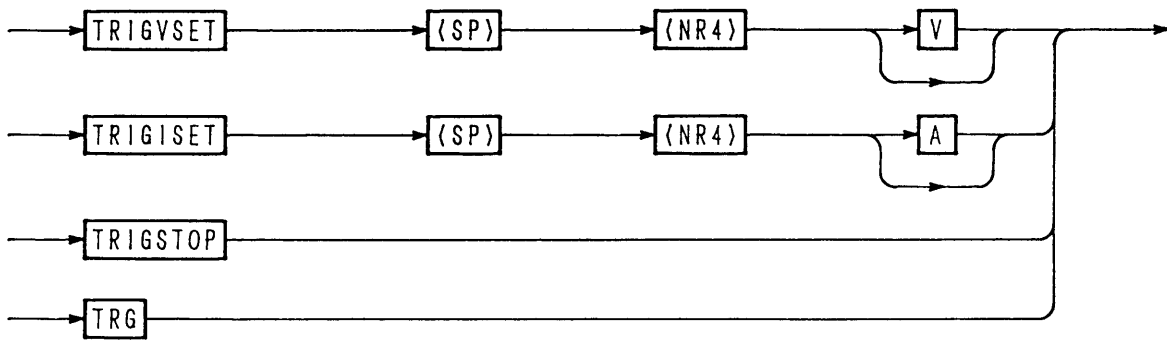

Header	Data	Action	Remarks
TRIGVSET	Real number [V]	Set the voltage to be output to the trigger buffer	
TRIGISET	Real number [A]	Set the current to be output to the trigger buffer	
TRIGSTOP	/	Clear the contents of trigger buffer	
TRIG	/	Execute the contents of trigger buffer	

NOTE

- The contents of the trigger buffer will be cleared if the trigger buffer is set by the **TRIGxxx** command and then another command is executed before executing the **TRG** command.
- Nothing will occur even when the **TRG** command is given if the trigger buffer is empty.
- When execution of the **TRG** command is over, the trigger buffer will become empty.
- Because there is only one trigger buffer, only one setting is done per one **TRG** command.
- The **TRIGVSET** + **TRG** and **TRIGISET** + **TRG** commands do not have the function that the Fine value automatically becomes zero.
- For the operation procedures, refer to Section 4.7 "Examples of Remote Programming," [6] "Example of program for MCB path address designation and simultaneous operation."

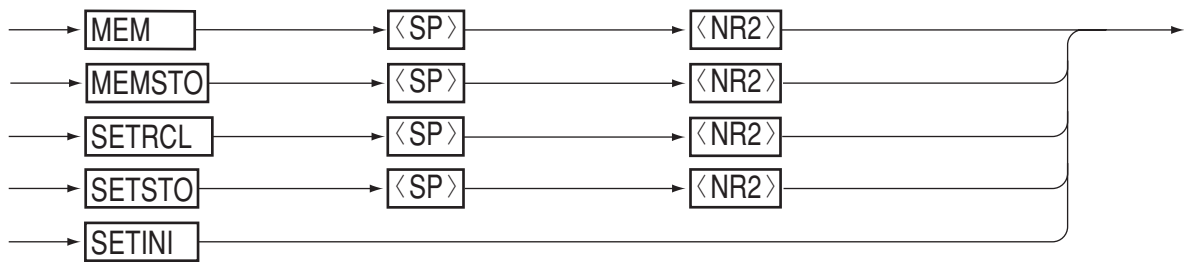
[3] Memory operation, and setup functions

Header	Data	Action	Remarks
MEM	1 to 4	Set the voltage and current with data stored in specified memory (1 for A, 2 for B, 3 for C, and 4 for D)	
MEMSTO	1 to 4	Store the currently existing voltage and current setup data onto memory	
SETRCL	0 to 9	Recall the setup file from specified memory	
SETSTO	0 to 9	Store the setup data into setup file of specified memory.	
SETINI		Initialize the setup to the factory-defaults.	

NOTE

- For the operation procedures, refer to Section 4.7 "Examples of Remote Programming," [4] "Example of program utilizing the memory function."

[4] Protection Commands

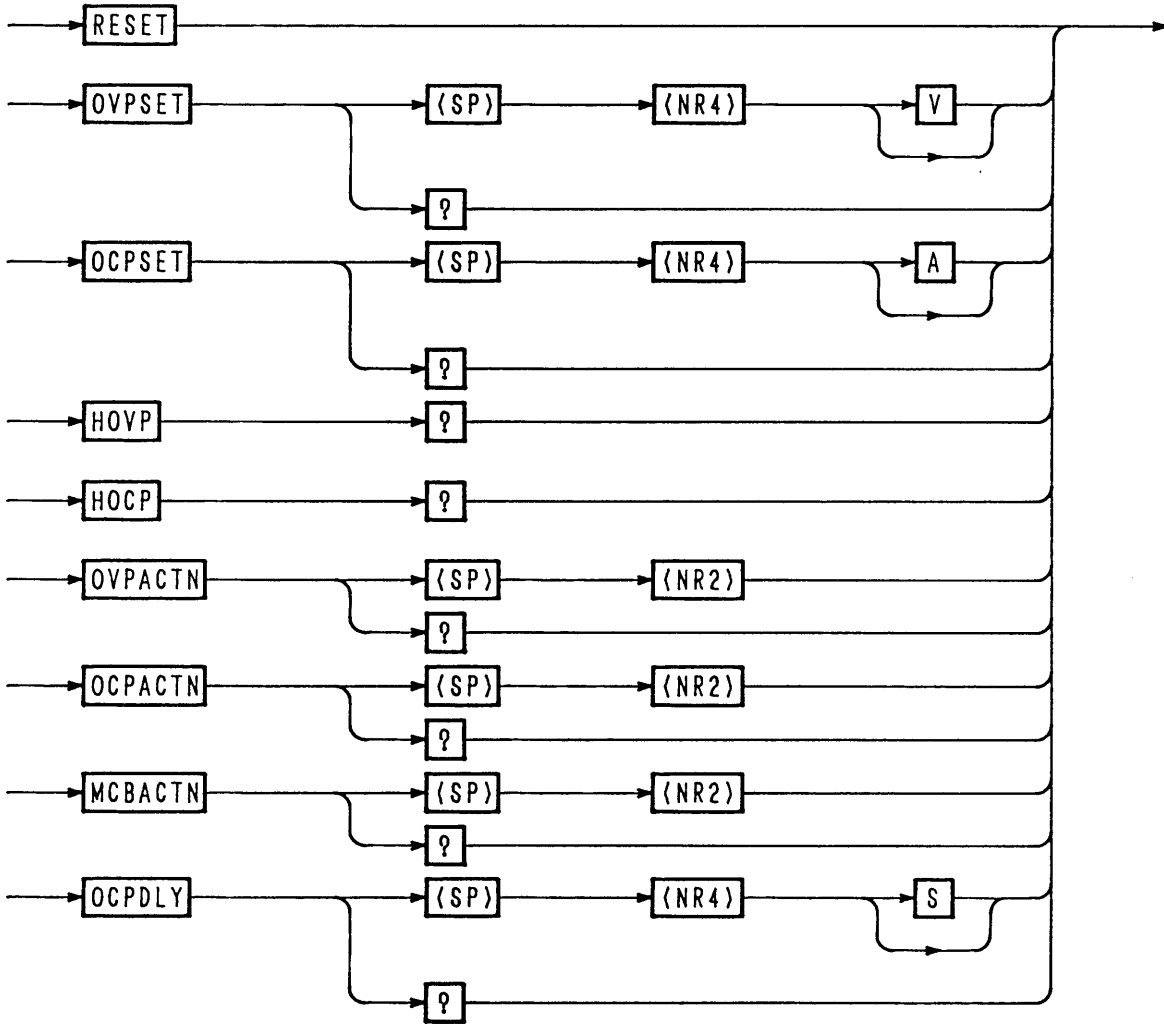

Header	Data	Action	Remarks
RESET		Reset from alarm status	
OVPSET	Real number [V]	Set the software OVP value	
OVPSET?		Return the set software OVP value	
OCPSET	Real number [A]	Set the software OCP value	
OCPSET?		Return the set software OCP value	
HOVP?		Return the hardware OVP value	
HOCP?		Return the hardware OCP value	
OVPACTN	1	Set to <OUTPUT OFF>	
	2	Set to <POWER OFF>	
	3	Set to <CROWBAR ON>	
OVPACTN?		Return 1, 2, or 3	
OCPACTN	1	Set to <OUTPUT OFF>	
	2	Set to <POWER OFF>	
OCPACTN?		Return 1 or 2	
MCBACTN	1	Disable MCB protection	
	2	Enable MCB protection	
MCBACTN?		Return 1 or 2	
OCPDLY	0.05 to 9.99 [s]	Set the delay time for OCP	
OCPDLY?		Return the OCP delay time	

[5] Sequence commands (1/2)

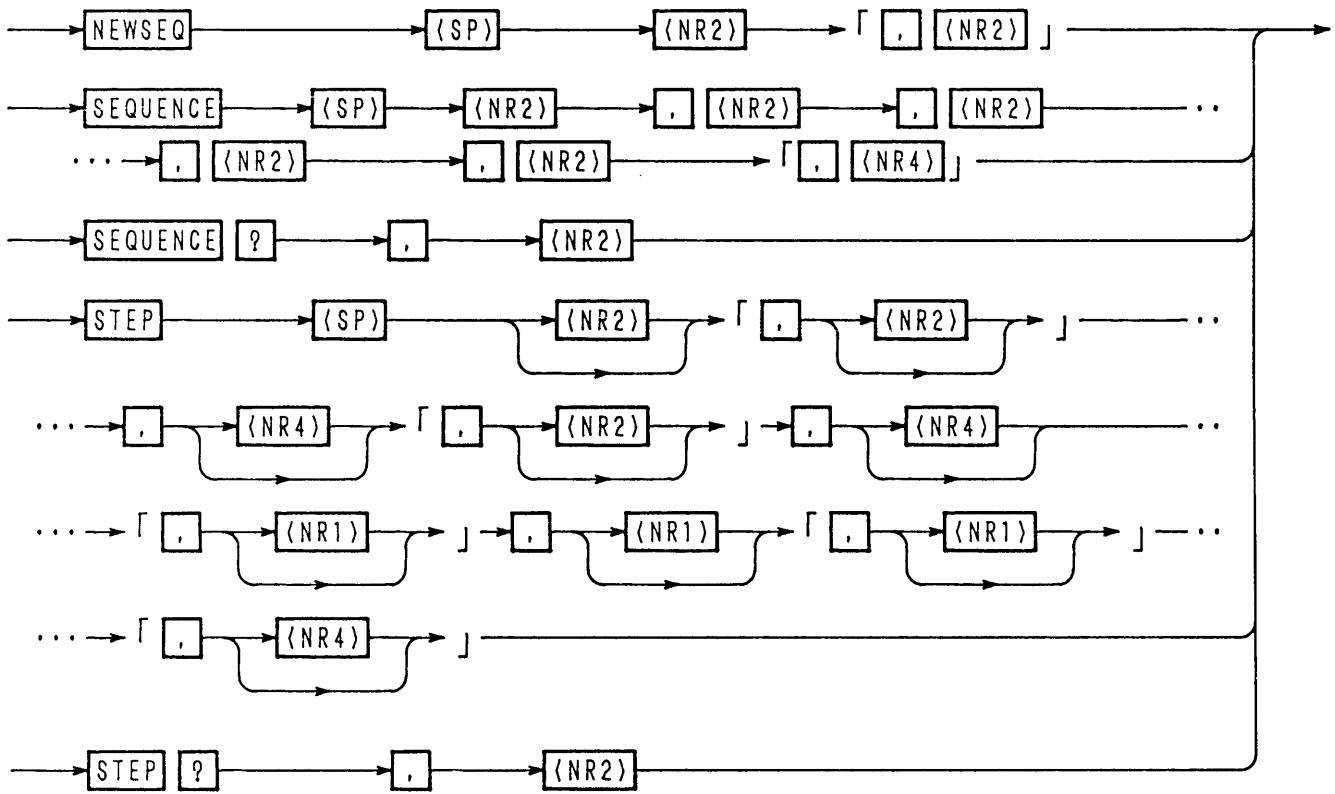

Header	Data	Action	Remarks	
NEWSEQ *2nd program data ② is not needed for FV and FI modes.	①	1	Set to NV mode	
		2	Set to NI mode	
		3	Set to NVI mode	
		10	Set to FV mode	
		11	Set to FI mode	
	②	1	Set the time unit to msec	
		2	Set the time unit to sec	
		3	Set the time unit to minute	
		4	Set the time unit to hour	
	SEQUENCE *6th program data ⑥ is not needed for NV, NI, and NVI mode.	①	1-8	
②		1-16	Specify the program to be run	
③		1-9999	Specify the number of loops (9999 for infinitive repetitions)	
④		0, 1-8	Specify the sequence number for not needed chain destination (0 for no chain)	
⑤		0, 1-16	Specify the end program number (0 for no end designation)	
⑥		0, 1- [ms]	Execution time in FV/FI mode	
SEQUENCE?		1-8	Return the parameter of specified sequence number	
STEP *No.2,4,7,8, and 9 program data ②, ④, ⑦, ⑧, and ⑨ are not needed for FV and FI modes.	①	1-256 (1024)	Specify the step number Up to 1024 for FV or FI mode (Default: Preceding step No. + 1)	*1 *2
		②	0	
	1		Specify rampwise change of output voltage	
	③	Real number [V]	Set the voltage value	
	④	0	Specify stepwise change of output current	
		1	Specify rampwise change of output current	
	⑤	Real number [A]	Specify the current value	
	⑥	0 (OFF)	Set the trigger output to OFF	
		1 (ON)	Set the trigger output to ON	
	⑦	0 (OFF)	Set the output to OFF	
		1 (ON)	Set the output to ON	
	⑧	0 (OFF)	Set the PAUSE to OFF	
		1 (ON)	Set the PAUSE to ON	
	⑨	Real number [s]	Set time data (in the unit of [sec] regardless of the time unit set by NEW SEQ)	
STEP?	1-256 (1024)	Return the parameter of the specified step number		

*1: Dummy value when in NI mode; not required when in FI mode.

*2: Dummy value when in NV mode; not required when in FV mode.

NOTE

- Program data of [STEP] command may be omitted. When omitted, no overwriting is made on the step parameter.
- For the operating method, refer to Section 4.7 "Examples of Remote Programming," [7] and [8] "Example of program for sequence operation."

[6] Sequence commands (2/2)

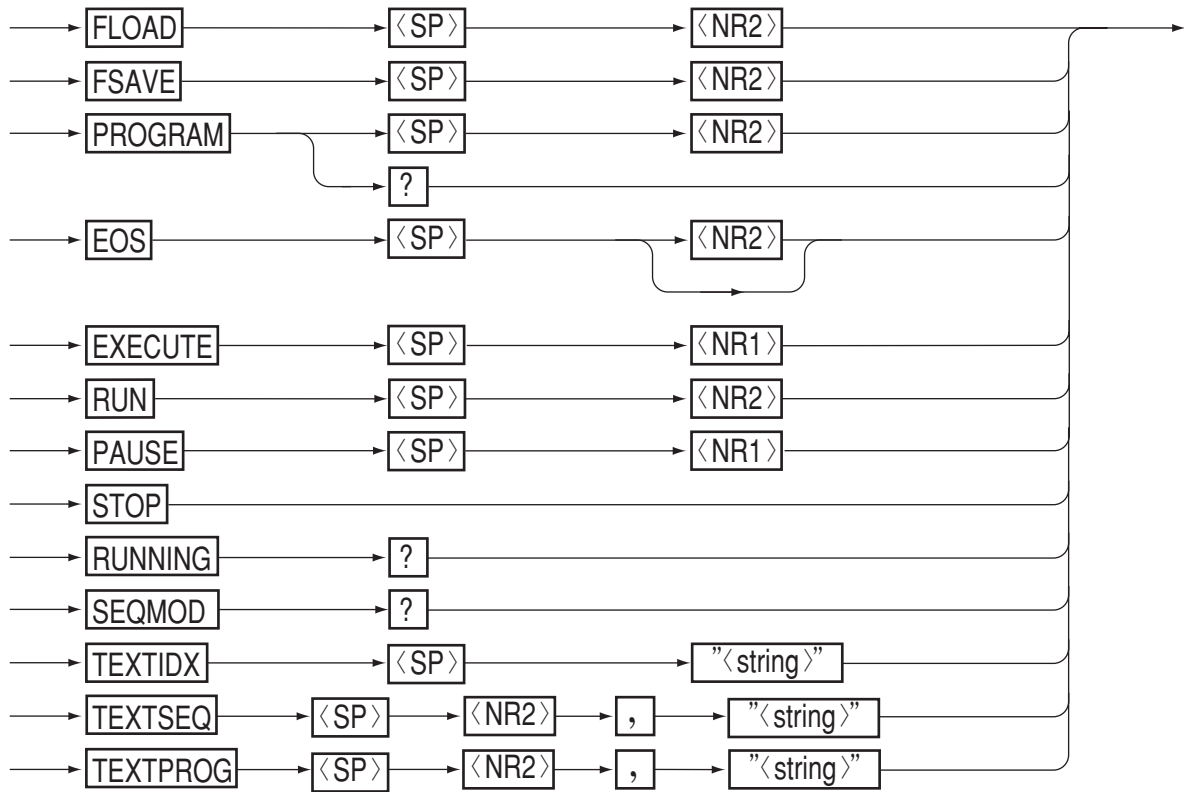

Header	Data	Action	marks
FLOAD	0-	Load the specified file to sequence execution memory	
FSAVE	0-	Save the sequence execution memory contents into the specified file	
PROGRAM	1-16	Specify the program number (Hereafter, effective for STEP and EOS commands)	
PROGRAM?		Return the specified program number	
EOS	1-1024 (256)	Set the final step number of the (256) specified program (Default: previous step number + 1)	
EXECUTE	1 (ON)	Set to the execute mode (RUN, STOP, PAUSE enabled)	*1
	0 (OFF)	Release from the execute mode	
RUN	1-8	Run the specified sequence number	
PAUSE	1 (ON)	Pause the sequence	
	0 (OFF)	Release the pause	
STOP		Stop the sequence forcibly	
RUNNING? <SEQ. NO>,		Return the sequence run status data (<STOP:1, RUN:2, PAUSE:3>, <SEQ.NO>, <PROG.NO>, <LOOP>, <STEP NO>)	
SEQMODE?		Return sequence mode data (<NV, NI, NVI, FV, FI>)	
TEXTIDX	Train of chara.	Provide an index with a train of up to six characters, for execution sequence memory	
TEXTSEQ	① 1-8	Specify the sequence number	
	② Train of chara.	Write a comment with a train of up to six characters, for the specified sequence number	
TEXTPROG	① 1-16	Specify the program number	
	② Train of chara.	Write a comment with a train of up to six characters, for the specified program number	

*1: During the EXECUTE mode, other program commands than **RUN**, **STOP**, **PAUSE**, and **RESET** are ineffective. When in the state released from the EXECUTE mode, the **RUN**, **STOP**, and **PAUSE** commands are ineffective.

[7] Utility commands

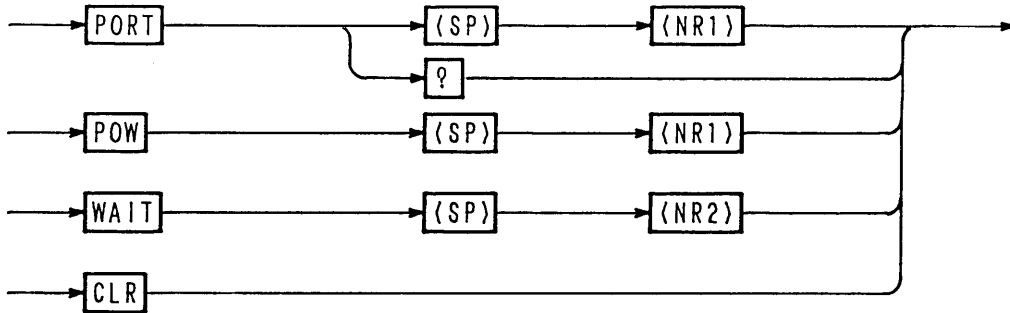

Header	Data	Action	Remarks
PORT	1(ON)	Turn ON (make closed) between digital common terminal and option terminal of J2 connector on rear panel	
	0(OFF)	Turn OFF (make open) between digital common terminal and option terminal of J2 connector on rear panel	
PORT?		Return 0 or 1	
POW	/		
	0(OFF)	Turn OFF the POWER switch	
WAIT	1-5	Wait for the <specified> period by doing nothing	
CLR	/	Clear the buffer, etc.	

NOTE

- The option terminal that is ON/OFF-controlled by the **PORT** command provides an open collector output of $I_c=50mA$ $V_{CE(SAT)}=0.5V$ (equivalent to Toshiba 2SC1815).

[8] Commands for MCB only

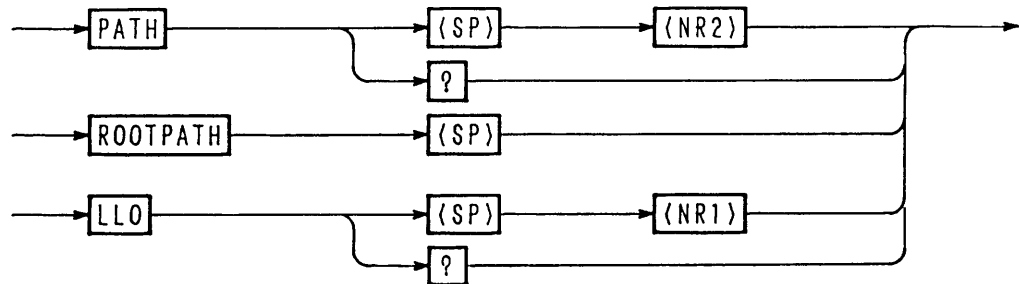

Header	Data	Action	Remarks
PATH	Address (0-15, 16)	Set the MCB path address (path address 16: for all addresses)	
PATH?		Return the MCB path address	
ROOTPATH		Set the path address to 0	
LLO	1 (ON)	Set to local lockout	
	0 (OFF)	Release from local lockout	
LLO?		Return 0 or 1	

Caution

- For the MCB path address, specify an address which actually exists. When you have specified an address which does not actually exist, send <DCL> to GPIB. The path address will be set to 0 (master).
- For answer to the query message on path address 16, data of path address 0 (master) will be returned.

NOTE

- For the operation procedures, refer to Section 4.7 "Examples of Remote Programming," [6] "Example of program for MCB path address designation and simultaneous operation."

[9] Commands and control codes for RS-232C only

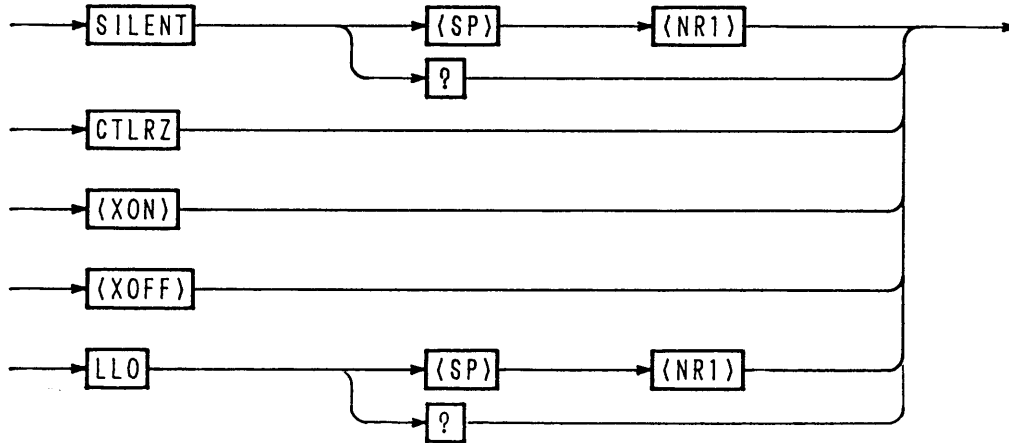

Header	Data	Action	Remarks
SILENT	1 (ON)	Do not return the acknowledge message	
	0 (OFF)	Return the acknowledge message	
SILENT?		Return 1 or 0	
CTRLZ		Return the code (1Ah)	
<XON> (11h)		Resume transmission from RS-11 (Refer to Section "Flow Control.")	
<XOFF> (13h)		Stop transmission from RS-11 (Refer to Section "Flow Control.")	
LLO	1 (ON)	Set to local lockout	
	2 (OFF)	Release from local lockout	
LLO?		Return 0 or 1	

[10] System commands

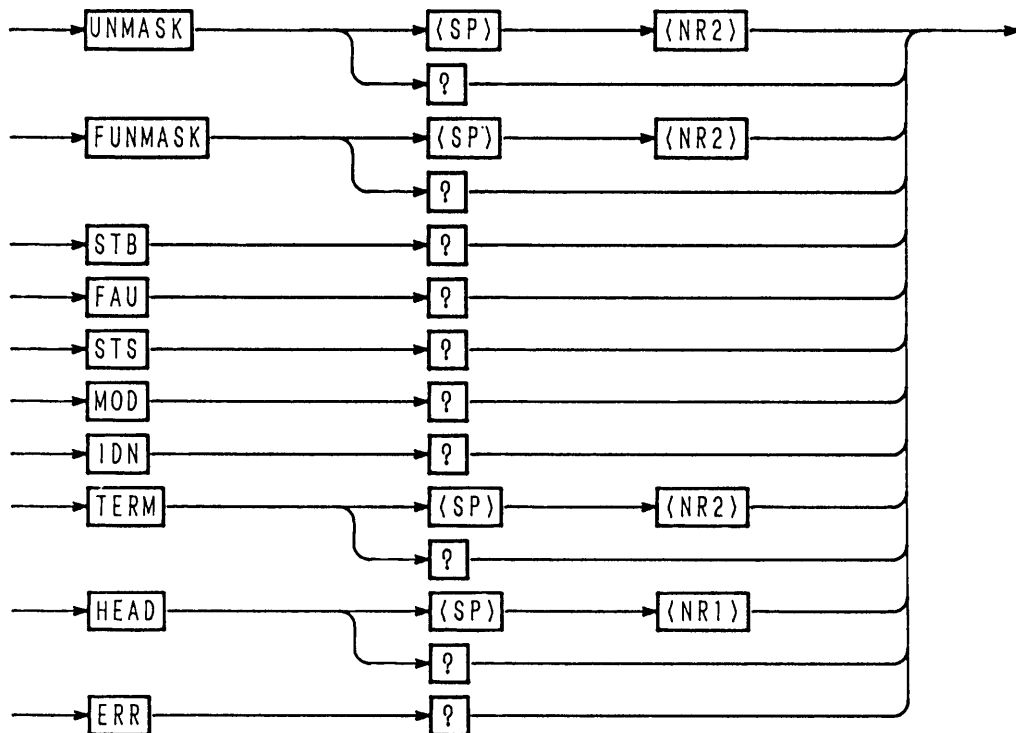

Header	Data	Action	Remarks
UNMASK	0-255	Set the unmask register	
UNMASK?		Return the UNMASK value in decimal	
FUNMASK	0-255	Set the fault unmask register	
FUNMASK?		Return the FUNMASK value in decimal	
STB?		Return the status byte register value in decimal	
FAU?		Return the fault register value in decimal	
STS?		Return the status fault register value in decimal	
MOD?		Return the mode register value in decimal	
IDN?		Return the model and ROM version number	
TERM	0	Set the response terminator to "CrLf"	
	1	Set the response terminator to "Cr"	
	2	Set the response terminator to "Lf"	
	3	Set the response terminator to "EOI"	
TERM?		Return 0, 1, 2 or 3	
HEAD	1 (ON)	Add a query header to the query message	
	0 (OFF)	Add no query header to the query message	
HEAD?		Return 0 or 1	
ERR?		Return error code (Refer to 4.6 "Table of Error Codes.")	

NOTE

- *For bit assignment of each of the registers, refer to Section 4.4 "Bit Assignment of Registers."*
- *For the operation procedures, refer to Section 4.7 "Examples of Remote Programming," [5] "Examples of program for setting of registers, call out, and SRQ."*

[11] Commands and special codes for GPIB only

Multiline message <DCL>: To set the MCB path address to 0. To clear the error message.

Multiline message <SDC>: The same as above.

Multiline message <GET>: The same as the **TRG** command.

"@" (40h): The "@" code (40h) suffixed to a program command is for hold off until execution of the message ends. However, in the event of a command message terminator with only EOI, use "@@".

Example

```

call Tx("VSET 5.0V")           ' Get message into the input buffer
                                ' and then proceed to the next

call Tx("VSET 5.0V@")         ' Execute "VSET 5.0V" and then
                                ' proceed to the next
    
```

4.4 Bit Assignment of Registers

[1] Status byte register

MSB				LSB			
7	6	5	4	3	2	1	0
X	RQS	X	MCB	ERR	SE	PON	FAU

Bit 0 [FAU] : Means that one of the fault register bits is "true."

Bit 1 [PON] : Means the power-on status.

Bit 2 [SE] : Means that the sequence is over.

Bit 3 [ERR] : Means that a syntax error has occurred.

Bit 4 [MCB] : Means that an SRQ is coming from MCB.

Bit 5 [X] : Undefined

Bit 6 [RQS] : Means that an SRQ is originated.

Bit 7 [X] : Undefined

NOTE

- Bit 1 [PON] and bit 6 [RQS] are effective for the IB11 interface board only.
- Bit 3 [ERR] can be reset with the **ERR?** query, **CLR** command, <DCL>, or <SDC>.
- Bit 6 [RQS] can be reset by serial polling of GPIB.
- Bit 1 [PON] and bit 2 [SE] are undefined for the **STB?** query.

[2] Unmask register

MSB				LSB			
7	6	5	4	3	2	1	0
0	0	0	MCB	ERR	SE	0	FAU

Bit 0 [FAU] : To originate an SRQ when one of the register bits is "true."

Bit 1 [0] : Not used

Bit 2 [SE] : To originate an SRQ when the sequence is over.

Bit 3 [ERR] : To originate an SRQ when a syntax error or other error has occurred.

Bit 4 [MCB] : To originate an SRQ as requested via MCB.

Bit 5 [0] : Not used

Bit 6 [0] : Not used

Bit 7 [0] : Not used

NOTE

- For the bits which are not used, set "0."

[3] Fault register

MSB				LSB			
7	6	5	4	3	2	1	0
X	OC	CC	CV	X	OHP	OCP	OVP

- Bit 0 [OVP] : OVP action
- Bit 1 [OCP] : OCP action
- Bit 2 [OHP] : OHP action
- Bit 3 [X] : Undefined
- Bit 4 [CV] : CV action
- Bit 5 [CC] : CC action
- Bit 6 [OC] : LIMIT action
- Bit 7 [X] : Undefined

NOTE • Each bit of the fault register has a latch function. It holds its set state until it is read by a [FAU?] query.

[4] Fault unmask register

MSB				LSB			
7	6	5	4	3	2	1	0
0	OC	CC	CV	0	OHP	OCP	OVP

- Bit 0 [OVP] : Enables the OVP bit of fault register.
- Bit 1 [OCP] : Enables the OCP bit of fault register.
- Bit 2 [OHP] : Enables the OHP bit of fault register.
- Bit 3 [0] : Not used
- Bit 4 [CV] : Enables the CV bit of fault register.
- Bit 5 [CC] : Enables the CC bit of fault register.
- Bit 6 [OC] : Enables the OC bit of fault register.
- Bit 7 [0] : Not used

NOTE • For the bits which are not used, set "0".

[5] Status register

MSB				LSB			
7	6	5	4	3	2	1	0
X	OC	CC	CV	X	OHP	OCP	OVP

- Bit 0 [OVP] : OVP action
- Bit 1 [OCP] : OCP action
- Bit 2 [OHP] : OHP action
- Bit 3 [X] : Undefined
- Bit 4 [CV] : CV action
- Bit 5 [CC] : CC action
- Bit 6 [OC] : LIMIT action
- Bit 7 [X] : Undefined

[6] Mode register

MSB

LSB

7	6	5	4	3	2	1	0
ERL1	ERL0	TIM1	TIM0	X	EOFF	CRW	FST

Bit 0 [FST] : For Fast mode "1" or Normal mode "0".

Bit 1 [CRW]: "1" when crowbar option is set.

Bit 2 [EOFF]: "1" when the output ON/OFF control of analog remote control terminal J2 on rear panel is set to OFF (short).

Bit 3 [X] : Undefined

Bit 4 [TIM0]: ON/OFF timing code 0 *1

Bit 5 [TIM1]: ON/OFF timing code 1 *1

Bit 6 [ERL0]: External remote status code 0 *2

Bit 7 [ERL1]: External remote status code 1 *2

*1: Table of ON/OFF

	TIM1	TIM0
Normal	0	0
CV mode	1	0
CC mode	1	1

*2: Table of external remote timing codes status codes

	ERL1	ERL0
Local	0	0
CV remote	0	1
CC remote	1	0
CV, CC remote	1	1

4.5 Relationships Among SRQ, Status Bytes, and Registers

The power supply has registers which are used to notify to the controller the events occurred in the supply. This section explains the relationships among SRQ, status bytes, and registers.

Relationships among SRQ, status bytes, and registers

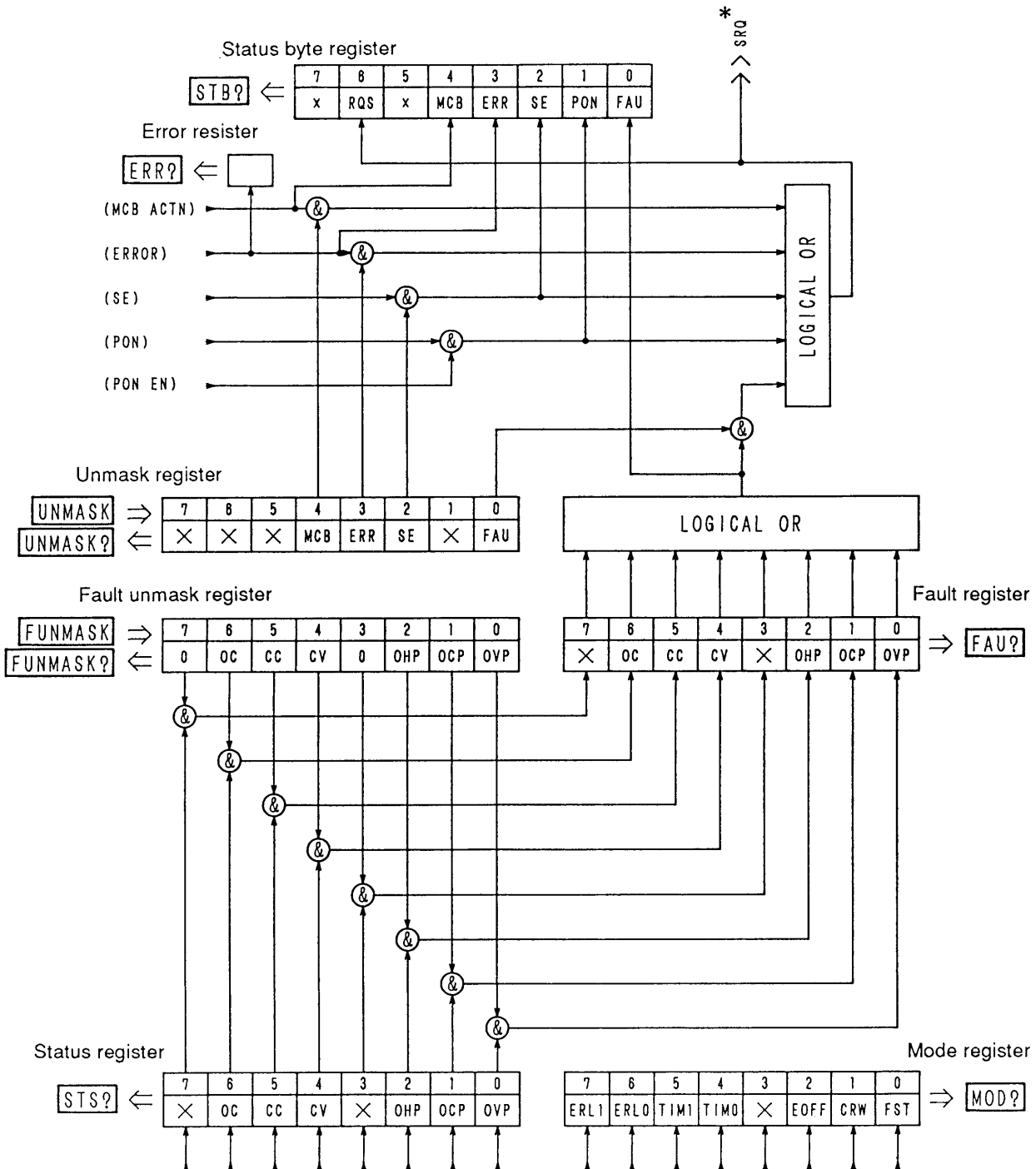

*SRQ is for GPIB only.

4.6 Table of Error Codes

Error code	Panel display
1	I/F Syntax Error.
2	I/F Argument Error.
51	Parity Error.
52	Framing Error.
53	RX Buff Overflow.
54	TX Buff Overflow.
60	I/F Invaild Data.
61	I/F Can't Execute.
62	I/F No Answer.
63	I/F Warning Data.
79	Data Clip.
80	Predication OVP.
81	Predication OCP.

NOTE

- Each time an error occurs, it is written onto the error register. Thus, the error code returned in response to the `ERR?` query is of the error which occurred latest. The error register is cleared when the `ERR?` query, `CLR` command, `<DCL>`, or `<SDC>` is given.
- For details of errors, refer to Appendix 1 "Table of Error Messages."

4.7 Examples of Remote Programming

4.7.1 Initializing the Interface Board

First of all, set the parameters of the interface board. The items to be set are as shown below. For the setting procedure, refer to Section 3.5.1 "Configuration".

GPIB interface board (IB11):

- GPIB device address
- Power-on service request

RS-232C interface board (RS11):

- Data transmission rate (bps)
- Data bit length
- Stop bit length
- Parity bit (Even/Odd/None)

MCB slave interface board (MC11S)

- MCB device address

4.7.2 Examples of Application Programs

Sample code (Visual Basic 6.0)

The sample program to be described later assumes Microsoft Visual Basic 6.0 for the development platform and VISA library (VISA COM) for the I/O library.

You can use the following either VISA libraries.

- Kikusui Corp.: KI-VISA
(VER.3.0.x or later, Downloadable from <http://www.kikusui.co.jp/download/>)
- National Instruments: NI-VISA
(VER.3.0 or later, Windows 2000 and Windows XP: VER.3.2 or later)
- Agilent Technologies: Agilent VISA
(Agilent IO Libraries M01.00 or later)

VISA Session Acquisition and Communication Setup

The codes listed below are common to all of the sample programs to be described later. They should be executed before holding a communication with this product.

The syntax of the VISA resource string to be substituted for variable `strVisaAddress` varies depending on GPIB and RS232C.

With GPIB, the use of device address 1 is supposed.

With RS232C, the communication parameters are supposed to be the factory-shipped parameters.

- Communication rate: 9600 bps
- Data length: 8 bits
- Stop bit: 1 bit
- Parity: NONE
- Flow control: XFlow
- Communication port: COM 1
- Terminator: CR+LF

The communication parameter setups of the program are described using the above values. Therefore, if the product condition is different from the factory-shipped condition, it is required to reset the product to the factory-shipped condition.

See "[4] Initialization" in section "3.3.3 Setup Function".

Common Modules

1. Communication IO open/close module

The GPIB or RS232C IC open/close module is a basic operation for communication and should be included in the standard module. After calling the comm_open function at the start of the program, be sure to call the comm_close function to close the communication port before the end of the program.

2. Setting/inquiry command send/receive module [Function Tx(send_data As String)]

After sending of a command that contains "?" in the command string, the reception operation is executed and the received data is saved in global variable [g_strRxd].

<<Include the following in the standard module>>

```
Option Explicit
Public Declare Sub Sleep Lib "kernel32" (ByVal dwMilliseconds As Long) 'sleep function for use with the API wait time.
'The following variables are required for control of VISA COM.
Public rm As VisaComLib.IResourceManager
Public io As VisaComLib.IMessage
Public serial As VisaComLib.ISerial
Public g_strRxd As String 'Global variable for receive data save
Public m_session_INTFC As VisaComLib.IGpibIntfc 'Library for use with GPIB interface commands
Public Const trg_on = "1" 'Sequence step trigger ON
Public Const trg_off = "0" 'Sequence step trigger OFF

'-----
Function comm_open()
'*****
' * Communication IO open module
' * The communication port is fixed as follows.
' * GPIB address: 1
' * RS232C port: COM1
' *
' * GPIB and RS232C are switched according to the string substituted for strVisaAddress.
' * This module sets READ to OFF after opening the communication port.
'*****
Dim strVisaAddress As String 'Specifies VISA address in the strVisaAddress variable.
'strVisaAddress = "ASRL1::INSTR" 'RS232C port setting * When RS232C is enabled, GPIB should be a comment.
strVisaAddress = "GPIB0::1::INSTR" 'GPIB address setting *When GPIB is enabled, RS232C should be a comment.

'Create a Resource Manager object.
'(Begin creation using the VISA Global Resource Manager; If this fails, try creation using the Agilent Resource Manager.)

On Error Resume Next
Set rm = CreateObject("VISA.GlobalRM")
If rm Is Nothing Then
Set rm = CreateObject("AgilentRM.SRMcls")
End If
On Error GoTo 0

'Open a VISA session.
Set io = rm.Open(strVisaAddress, NO_LOCK)

'Set RS232C-specific communication parameters.
```



```

If io.HardwareInterfaceType = INTF_ASRL Then      'When IO resource is RS232C, execute following settings.
    Set serial = io                               'RS232C
    serial.BaudRate = 9600                        'Baud rate 9600 bps
    serial.DataBits = 8                          'Data length 8 bits
    serial.StopBits = ASRL_STOP_ONE              'Sets stop bit to 1 bit.
    serial.Parity = ASRL_PAR_NONE                'Sets parity bit to NONE.
    serial.FlowControl = ASRL_FLOW_XON_XOFF      'Sets flow control Xon/off.
    serial.Timeout = 5000                        'Sets timeout to 5 sec. (The default without this setting is 2 sec.)

ElseIf io.HardwareInterfaceType = INTF_GPIB Then 'Only when GPIB is used.
    Set m_session_INTFC = rm.Open("GPIB0::INTFC") 'Enables interface message.
End If

    Call Tx("HEAD OFF")                          'Sets HEAD OFF.
End Function

'-----
Function comm_close()
    '*****
    '* Communication IO close module
    '* Close communication port and INTFC (multi-line message, etc.).
    '*****

    'Close the VISA session
    If rm Is Nothing Then Exit Function
    io.Close
    If m_session_INTFC Is Nothing Then Exit Function
    m_session_INTFC.Close
End Function

'-----
Function Tx(send_data As String)
    '*****
    '* Send/receive module
    '* Send method: call ("ascii code string")+CR+LF
    '* With this module, terminator CR+LF is added after the string.
    '*
    '* Receive operation is executed with a query command that contains (?).
    '* Receive data is saved in global variable g_strRxd.
    '*****

    On Error Resume Next
    io.WriteString send_data + vbCrLf           'Sends command+CR+LF

    If InStr(send_data, "?") Then               'Identifies a query command.
        g_strRxd = io.ReadString(256)          'Receive data is substituted for global variable q_strRxd.
    End If
End Function

```

Sample Program

To use the following sample program, create a form, provide an optimum command button and use function call.

• Example:

```
Private Sub Command1_Click()
    Call comm_open           'Opens communication port.
    Call example001         'Executes sample program 001.
    Call comm_close        'Closes communication port.
End Sub
```

[1] Example of voltage setup and monitor read-back

```
Sub example001()
    'Sample program 1
    '[1] Example of voltage setup and monitor read-back
    'Data format (The unit is omitted, and v, index, mV and KV can be used.)
    'Set voltage query value is substituted for global variable g_strRxd.
    '<<VSET,VSET?,VOUT?,ISET/ISET?,IOUT?>>
    Dim dVoltMeasure As Double           'Measured voltage variable: Double type
    Call Tx("VSET 5.00")                 'Sets voltage to 5.00 V.
    Call Tx("OUT ON")                   'Output ON
    dVoltMeasure = Meas_vout             'Set voltage query/output voltage query
    Call Tx("VSET 0.00V")               'Sets voltage to 0.00 V.
    dVoltMeasure = Meas_vout             'Set voltage query/output voltage query
    Call Tx("VSET 4.75E+0")             'Sets voltage to 4.75 V.
    dVoltMeasure = Meas_vout             'Set voltage query/output voltage query
    Call Tx("VSET 5250mV")              'Sets voltage to 5.25 V.
    dVoltMeasure = Meas_vout             'Set voltage query/output voltage query
    Call Tx("VSET 0.005KV")             'Sets voltage to 5.00 V.
    dVoltMeasure = Meas_vout             'Set voltage query/output voltage query
    '-----

    Dim dVoltset As Double
    Dim dVoltMeasure As Double

    dVoltMeasure = Meas_vout             'Substitutes output voltage for variable dVoltMeasure.
    dVoltset = Val(g_strRxd)            'Substitutes set voltage for variable dVolset.

    Dim dCurrentset As Double
    Dim dCurrMeasure As Double
    dCurrMeasure = Meas_Iout             'Substitutes output current for variable dCurrMeasure.
    dCurrentset = Val(g_strRxd)         'Substitutes set current for variable dCurrentset.

    Call Tx("OUT OFF")                  'Output OFF
End Sub
'-----

Function Meas_vout() As Double
    'Set voltage query/output voltage query function
    Dim dVoltMeasure As Double           'Measured voltage variable: Double type
    Sleep (1000)                         'Sets rise delay time to 1 sec.
    Call Tx("VOUT?")                     'Saves output voltage query value in q_strRxd.
    dVoltMeasure = Val(g_strRxd)         'Converts character data into Double type numerical data.
    Meas_vout = dVoltMeasure
    Call Tx("VSET?")                     'Set voltage query
End Function
'-----
```

```

Function Meas_Iout() As Double
    'Set voltage query/Output voltage query
    Dim dCurrentMeasure As Double
    Sleep (1000)
    Call Tx("IOUT?")
    dCurrentMeasure = Val(g_strRxd)
    Meas_Iout = dCurrentMeasure
    Call Tx("ISET?")
End Function

```

' Measured current variable: Double type
 ' Sets rise delay time to 1 sec.
 ' Saves output current query value in g_strRxd.
 ' Converts character data into Double type numerical data.
 ' Set current query

[2] Example of protection operation

```

Sub example002()
    'Sample program 2
    '[2] Example of protection operation
    'Query value is substituted for global variable g_strRxd.
    '<<Protection>>
    '-----Settings-----
    Call Tx("OVPSET 5.5;OCPSET 8.5")

    Call Tx("OVPACTN 1;OCPACTN 2;OCPDLY 1.5S")

    '-----Query value save variable-----
    Dim dOVP_Data As Double
    Dim dOCP_Data As Double

    Dim ioVPaction_Data As Integer
    Dim ioCPaction_Data As Integer
    Dim dOCPDLY_Data As Double

    Dim dHOPV_Data As Double
    Dim dHOCP_Data As Double

    '-----Query-----
    Call Tx("OVPSET?")
    dOVP_Data = Val(g_strRxd)

    Call Tx("OCPSET?")
    dOCP_Data = Val(g_strRxd)

    Call Tx("OVPACTN?")
    ioVPaction_Data = Val(g_strRxd)

    Call Tx("OCPACTN?")
    ioCPaction_Data = Val(g_strRxd)

    Call Tx("OCPDLY?")
    dOCPDLY_Data = Val(g_strRxd)

    Call Tx("HOVP?")
    dHOPV_Data = Val(g_strRxd)

    Call Tx("HOCP?")
    dHOCP_Data = Val(g_strRxd)
End Sub

```

' Sets OVP/OCP value.
 ' Action 1 during protection: 1: OUT OFF 2:PWR OFF
 ' Sets limit delay time to 1.5 sec. (Setting range: 0.05-9.9 sec.)
 ' OVP set data save variable
 ' OCP set data save variable
 ' OVP action set data save variable
 ' OCP action set data save variable
 ' OCP delay data save variable
 ' Hardware OVP data save variable
 ' Hardware OCP data save variable
 ' OVP set value query
 ' Converts query data into numerical data.
 ' OCP set value query
 ' Converts query data into numerical data.
 ' OVP action set data query
 ' Converts query data into numerical data.
 ' OCP action set data save variable query
 ' Converts query data into numerical data.
 ' OCP delay set data query
 ' Converts query data into numerical data.
 ' Hardware + voltage limit value query
 ' Converts query data into numerical data.
 ' Hardware - voltage limit value query
 ' Converts query data into numerical data.

[3] Example of fine adjustment setting

```

Sub example003(d_setvoltage As Double)
  'Sample program 3
  '[3] Example of find adjustment setting: call example003(12.000V)
  'This sample fine adjusts the output voltage to ±1 mV of the set value.
  'To reach the set value quickly, the previously calculated fine setting value is sent and then subjected to fine adjustment.
  'Software Auto Fine function
  'FINE setting range: -128 to 127
  'Command syntax: VFINE <set value>
  '<<Fine>>

  Dim d_fine_dif_val As Double          ' Variable of the difference between set and output values.
  Dim volt_fine As Integer              ' FINE set value variable
  volt_fine = 0
  Call Tx("VSET" & Str$(d_setvoltage))
  Call Tx("OUT ON")                    ' Output ON

  d_fine_dif_val = d_setvoltage - Wait_ReadBack ' Calculates the difference between set and output values.
  volt_fine = d_fine_dif_val / 0.0006        ' Calculates expected FINE set value (calculation for reducing processing time).
                                              ' (Constant, which is 0.0006 in this example, varies depending on product.)

  If volt_fine <= -128 Then              ' If FINE set value is below negative limit:
    volt_fine = -128                     ' Sets FINE set value to -128.
    MsgBox "The - setting limit of FINE is exceeded." ' Message
  ElseIf volt_fine >= 127 Then           ' If FINE set value is above positive limit:
    volt_fine = 127                       ' Sets FINE set value to 127.
    MsgBox "The + setting limit of FINE is exceeded." ' Message
  End If
  Call Tx("VFINE " & Format(volt_fine))   ' Sets coarse FINE value.

  Do                                     ' Sets FINE value fine adjustment.
    DoEvents
    d_fine_dif_val = d_setvoltage - Wait_ReadBack ' Calculates the difference between set and output values.
    Debug.Print d_fine_dif_val
    If Abs(d_fine_dif_val) > 0.0011 Then      ' Executes FINE operation if the difference between set and output values is 1.1 mV or more.
      If d_fine_dif_val < 0 Then             ' If output voltage is higher than set value --> FINE-.
        'FINE_minus process
        If volt_fine < -128 Then Exit Do     ' Exits if FINE_minus is lower than minimum value.
        Call Tx("VFINE " & Format(volt_fine)) ' Sets FINE.
        volt_fine = volt_fine - 1
      Else                                   ' If output voltage is lower than set value --> FINE+.
        'FINE_plus process
        volt_fine = volt_fine + 1
        If volt_fine > 127 Then Exit Do     ' Exits if FINE_plus is larger than maximum value.
        Call Tx("VFINE " & Format(volt_fine)) ' Sets FINE.
      End If
    Else
      Exit Do
    End If
  Loop
End Sub

'-----
Function Wait_ReadBack() As Double
  Sleep (1000)                            ' Sets rise delay time to 1 sec.
  Call Tx("VOUT?")                         ' Saves output voltage query value in g_strRxd.
  Wait_ReadBack = Val(g_strRxd)            ' Converts character data into Double type numerical data.
End Function

```

[4] Example of use of memory function

```

Sub example004()
  'Sample program 4
  '[4] Example of use of memory function
  'Frequently used settings can be stored in memory (A, B, C and D).
  'Settings stored in memory can be recalled later.
  'The voltage and FINE set values are stored together.

  'This sample program stores the 4.750 V FINE setting in memory A.
  'This sample program stores the 5.000 V FINE setting in memory B.
  'This sample program stores the 5.250 V FINE setting in memory C.
  'This sample program stores the 0.000 V FINE setting in memory D.
  'Memories A, B, C and D are read in 1 sec. after storage. The recall interval is set to 1 sec.
  'STORE command syntax: MMSTO <1-4>
  'RECALL command syntax: MEM <1-4>
  '<<MEMORY STO/RCL>>

  Dim d_setvoltage As Double           'Set voltage variable
  Dim icount As Integer                'Counter variable

  d_setvoltage = 4.5                  'Initial voltage setting value

  For icount = 1 To 4                 '1:A 2:B 3:C 4:D

    If icount = 4 Then                'Sets 0.000 if icount = 4(D).
      d_setvoltage = 0
    Else
      d_setvoltage = d_setvoltage + 0.25 'Voltage set value +0.25 V
    End If

    Call example003(d_setvoltage)      'Calls voltage FINE setting function.
    Call Tx("MEMSTO" + Str$(icount)) 'Memory storage
  Next

  Call Tx("VSET 0.000")               'Resets voltage setting to 0.00 V.
  MsgBox "Memory storage operation is completed." 'Debugging message

  For icount = 1 To 4
    DoEvents
    Call Tx("MEM" + Str$(icount))     'Memory recall (of memory A, B, C)
    Call Wait_ReadBack                 'Reads output voltage.
    Sleep (1000)                       'Waits for 1 sec.
  Next
  MsgBox "Memory recall operation is completed." 'Debugging message
End Sub

```

[5] Examples of register settings/recalling and SRQ operation

```

Sub example005()
  'Sample program 5 [Valid only in GPIB communication]
  '[5] Example of register settings/recalling and SRQ operation
  'This sample program activates the current limit and generates SRQ at the Delayed Limit bit of FAU register bit 1 [DLIM].
  'This sample program checks the operation of SRQ by means of serial polling.
  'Related registers:
  ' STS? (Status register): Read-only register
  ' FUNMASK (Fault unmask register): Read/write register
  ' FUN? (Fault register): Read-only register (which is cleared after being read.)
  ' UNMASK (Unmask register): Read/write register
  ' STB? (Status byte register): Read-only register (which is cleared after being read.)
  ' Serial poll register (Status byte register): Read-only register
  ' The RQS bit is cleared after readout. If the SRQ factor remains in the cause register, the factor is not cleared.
  ' With OVP, alarm is generated after OVP detection. This alarm is reset by sending the RESET command.
  ' After resetting the alarm, it is required to read and then clear the FAU and serial poll registers.

  'Service requests
  '<<SRQ>>
  Dim vset As Double
  vset = 15
  On Error Resume Next
  Call Tx("UNMASK 1;FUNMASK 1")           ' Sets unmask register and fault unmask register.
  Call Tx("OVPSET 17.5;ISET 1.50")       ' Sets OVP to 17.5 V and current limit to 1.5 A.
  Call Tx("OVPACTN 1")                   ' Action 1 when limited: OUT OFF, Delay time 0.05 sec.
  Call Tx("VSET" + Str$(vset))           ' Sets voltage to 15.0 V.
  Call Tx("OUT ON")                       ' Turns output ON.
  Call Tx("CLR")                          ' Clears registers.

  Dim retVal As Integer

  Do
    DoEvents
    Call Tx("VSET" + Str$(vset))
    retVal = io.ReadSTB                    ' Serial polling
    'Debug.Print retVal
    Sleep (200)                            ' Delay

    vset = vset + 0.1
  Loop Until retVal > 64                   ' Loops until SRQ rises.

  Dim spoll_result As String
  spoll_result = SRQ_analyze(retVal)       ' Calls service request analysis.
  MsgBox spoll_result + vbCrLf + vbCrLf + "generated." ' Displays analysis result.

  -----
  Call Tx("RESET")                        ' Resets alarm.
  Call Tx("SETINI")                       ' Restores settings to factory-shipped settings.
  Call Tx("FAU?")                          ' Clears fault register after alarm reset.
  retVal = io.ReadSTB                      ' Clears serial poll register after alarm reset.
End Sub

' -----
Function SRQ_analyze(spoll_data As Integer) As String
  'Service request analysis
  'After serial polling, the contents of the status byte register are analyzed.
  'If summary bit is ON, the contents of the register corresponding to the summary bit is queried and analyzed.
  Dim i As Integer
  Dim STBreg(7) As Integer

```

```

Dim FAUreg(7) As Integer
Dim ERRreg(7) As Integer

'-----Status byte register analysis-----
For i = 7 To 0 Step -1
    If spoll_data - 2 ^ i < 0 Then
        STBreg(i) = 0
    Else
        spoll_data = spoll_data - 2 ^ i
        STBreg(i) = 1
    End If
Next
If STBreg(0) = 1 Then SRQ_analyze = "FAU"
If STBreg(1) = 1 Then SRQ_analyze = "PON"
If STBreg(2) = 1 Then SRQ_analyze = "SEQ END"
If STBreg(3) = 1 Then SRQ_analyze = "ERR"
If STBreg(4) = 1 Then SRQ_analyze = "MCB"
If STBreg(6) = 1 Then SRQ_analyze = "RQS"
'-----Fault register analysis-----
If STBreg(0) = 1 Then
    Call Tx("FAU?")
    spoll_data = Val(g_strRxd)

    For i = 7 To 0 Step -1
        If spoll_data - 2 ^ i < 0 Then
            FAUreg(i) = 0
        Else
            spoll_data = spoll_data - 2 ^ i
            FAUreg(i) = 1
        End If
    Next

    If FAUreg(0) = 1 Then SRQ_analyze = "OVP"
    If FAUreg(1) = 1 Then SRQ_analyze = "OCP"
    If FAUreg(2) = 1 Then SRQ_analyze = "OHP"
    If FAUreg(4) = 1 Then SRQ_analyze = "CV"
    If FAUreg(5) = 1 Then SRQ_analyze = "CC"
    If FAUreg(6) = 1 Then SRQ_analyze = "OC"
End If
'-----Error register analysis-----
If STBreg(3) = 1 Then
    Call Tx("ERR?")
    spoll_data = Val(g_strRxd)

    Select Case spoll_data

        Case 0
            SRQ_analyze = "No error."
        Case 1
            SRQ_analyze = "I/F syntax error."
        Case 2
            SRQ_analyze = "I/F argument error."
        Case 51
            SRQ_analyze = "Parity error."
        Case 52
            SRQ_analyze = "Franning error."
        Case 53
            SRQ_analyze = "RX Buff overflow."
        Case 54
            SRQ_analyze = "RX Buff overflow."
    End Select

```

```

'Decomposes query into 8 bits.
'Substitutes 0 and 1 for STBreg(0) to STBreg(7).

'If serial poll register bit 0 is 1, FAU is returned.
'If serial poll register bit 1 is 1, PON is returned.
'If serial poll register bit 2 is 1, SE is returned.
'If serial poll register bit 3 is 1, ERR is returned.
'If serial poll register bit 4 is 1, MCB is returned.
'If serial poll register bit 6 is 1, RQS is returned.

'Fault register summary bit ON
'Fault register query
'Converts FAU? query into numerical data.

'Decomposes query into 8 bits.
'0 and 1 are substituted for FAUreg(0) to FAUreg(7).

'If bit 0 is 1, OVP is returned.
'If bit 1 is 1, OCP is returned.
'If bit 2 is 1, OHP is returned.
'If bit 4 is 1, CV is returned.
'If bit 5 is 1, CC is returned.
'If bit 6 is 1, OC is returned.

'Error register summary bit ON
'Fault register query

```

```

Case 60
    SRQ_analyze = "I/F invalid data."
Case 61
    SRQ_analyze = "I/F can't execute."
Case 62
    SRQ_analyze = "I/F No answer."
Case 63
    SRQ_analyze = "I/F warning data."
Case 79
    SRQ_analyze = "Data clip."
Case 80
    SRQ_analyze = "Prediction V Limit"
Case 81
    SRQ_analyze = "Prediction V Limit"
Case Else
    SRQ_analyze = "Other error."
End Select
End If

If STBreg(4) = 1 Then SRQ_analyze = "MCB"           ' MCB ATCM bit ON

End Function

```

[6] Example of MCB path address specification and simultaneous operations

```

Sub example006()
    'Sample program 6 [Common to GPIB/RS232C]
    '[6] Example of MCB bus address specification and simultaneous operations
    'This sample program controls multiple PAX units at the same timing. The second and later PAXs need option boards.
    'Set the slave device address of the MCB11S option board to one of 1 to 15 using the configuration function of the main body.
    'Set the trigger voltage to multiple PAXs to let them output voltages simultaneously according to the GET or TRG command.
    'MCB master address: Fixed at 0, MCB slave address: 1 to 15
    'Specifying MCB address to 16 selects all MCBs.
    'The GET interface message can be used only in GPIB communication. The TRG command should be used in RS232C communication.
    '<<MCB>>
    Call Tx("PATH 0")           ' Specifies master address.
    Call Tx("VSET 0;OUT ON;TRIGVSET 5@") ' Sets trigger voltage to 5 V.

    '-----The following part of program remains a comment except when MCB is connected.-----
    'Call Tx("PATH 1")           ' Specifies slave address.
    'Call Tx("VSET 0;OUT ON;TRIGVSET 12@") ' Sets trigger voltage to 12V.
    '-----

    Call GET_operation           ' Issues GET command (valid only with GPIB; TRG command is used with RS232C.)
    'Call Tx("TRG")             ' In case of RS232C
    Sleep (5000)                 ' Wait time of 5 sec.
    Call Tx("PATH 16;TRIGVSET 0@") ' Sets trigger voltages of all devices to 0 V.
    Call Tx("TRG")               ' Issues TRG command (both GPIB/RS232C).
End Sub

'-----
Sub GET_operation()
    Dim buff_ary(5) As Byte
    Dim count As Long
    Dim retVal As Long
    Dim GPIB_ADDRESS As Integer

```



```

GPIB_ADDRESS = 1
buff_ary(0) = &H3F                                'UNL
buff_ary(1) = &H40                                'TA
buff_ary(2) = &H20 + GPIB_ADDRESS                 'MLA1
buff_ary(3) = &H8                                 'GET
count = 4                                          'Sent byte count
retVal = m_session_INTFC.Command(buff_ary, count)
End Sub

```

[7] Example 1 of sequence operation [NVI mode]

```

Sub example007()
' Set the short piece on rear panel to NORMAL.
' Sample program 7 [Normal sequence registration]
' This sample program registers a new sequence.
' (1) Sequence mode setting
' NEWSEQ <Mode,TimeUnit> [1:NV 2:NI],[1:TimeUnit ms 2:TimeUnit sec 3:TimeUnit minute 4:TimeUnit hour]
' Mode query command: SEQMODE? query is answered in numerical data. [1:NV 2:NI]
'
' (2) Sequence setting
' SEQUENCE <SEQ_No,PROG_No,LOOP_value,Chain_SEQ_No,End_prog_No>
' SEQ_No <1-8> PROG_No <1-8>
' Sequence query command: SEQUENCE?, <1-8> query is answered, for example, as "1,1,10,2,0".
'
' (3) PROGRAM number setting
' PROGRAM <1-16>
' Program number query command: PROGRAM? query is answered in 1-16.
'
' (4) Step setting [Maximum number of steps in NV and NI modes: 256 steps]
' STEP <Step_No,Lamp_on_off,VoltSet_value,Lamp_on_off,CurrentSet_value,TRG_on_off,Out_on_off,Pause_on_off,time>
' Step_No <1-256>
' Voltage lamp <ON,OFF>
' Voltage set value
' Current lamp <ON,OFF>
' Current set value
' Trigger output <1:ON 0:OFF>
' Pause setting ON/OFF <1:ON 0:OFF>
' Execution time setting
' Step query command: STEP?, <Step number> query is answered, for example, as "1,1,1,2,16".
'
' (5) Program final line specification
' EOS <Step number> If step number is omitted, data is written in the step of the last step number + 1.

' Example 1 of sequence operation (NVI mode)
' <<NORMAL SEQUENCE SAMPLE>>

' ----- Mode -----
Call Tx("EXECUTE 0")                                'Exits sequence execution mode.
Call Tx("NEWSEQ 3,1")                              'Specifies normal sequence [NVI] mode.
' ----- Sequence -----
Call Tx("SEQUENCE 1,1,1,2,16")
Call Tx("SEQUENCE 2,2,2,3,16")
Call Tx("SEQUENCE 3,3,1,0,16")
' ----- Program -----
Call Tx("PROGRAM 1")                                'Specifies PROGRAM 1.
Call Tx("STEP 1,0,0.00V,0,5.0A,0,1,0,50ms")
Call Tx("EOS")                                       'Sends EOS.

```

```

Call Tx("PROGRAM 2") ' Specifies PROGRAM 2.
  Call Tx("STEP 1,1,10.00V,0,5.0A,1,1,0,10ms")
  Call Tx("STEP 2,0,10.00V,0,5.0A,0,1,0,20ms")
  Call Tx("STEP 3,1,16.00V,0,5.0A,0,1,0,30ms")
  Call Tx("STEP 4,1, 0.00V,0,5.0A,0,1,0,40ms")
Call Tx("EOS") ' Sends EOS.

Call Tx("PROGRAM 3") ' Specifies PROGRAM 3.
' If STEP number is omitted, last step number + 1 is set.
  Call Tx("STEP 1,0, 5.00V,0,5.0A,0,1,0,30ms")
  Call Tx("STEP ,0,15.00V,0,5.0A,0,1,0,20ms")
  Call Tx("STEP ,1, 0.00V,0,5.0A,0,1,0,50ms")
Call Tx("EOS") ' Sends EOS.

Call Tx("PROGRAM 16") ' Specifies PROGRAM 16.
Call Tx("STEP 1,0, 0.00V,0,5.0A,0,0,0, 1ms")
Call Tx("EOS") ' Sends EOS.

'----- SAVE to EEPROM -----
Call Tx("FSAVE 0@") ' Saves file.
Call Sequence_RUN ' Executes sequence.

```

End Sub

[8] Example 2 of sequence operation (FV mode)

```

Sub example008()
' Set the short piece on rear panel to FAST.
' Sample program 8 [Fast sequence registration]
' This sample program registers a new sequence.
' (1) Sequence mode setting
' NEWSEQ <10|11> [10: FV 11:FI]
' Mode query command: SEQMODE? query is answered in numerical data. [10: FV 11:FI]
'
' (2) Sequence setting
' SEQUENCE <SEQ_No,PROG_No,LOOP_value,Chain_SEQ_No,End_prog_No,time>
' SEQ_No <1-8> PROG_No <1-8>
' Sequence query command: SEQUENCE?, <1-8> query is answered, for example, as "1,1,100,0,0,0.0001".
'
' (3) PROGRAM number setting
' PROGRAM <1-16>
' Program number query command: PROGRAM? query is answered in 1-16.
'
' (4) Step setting [Maximum number of steps in FV and NI modes: 1024 steps]
' STEP <Step_No,Set_value,TRG_on_off> TRG_on_off
' Step_No <1-1024> Set_value <Voltage/current set values> TRG_on_off<1:ON 0:OFF>
' Step query command: STEP?, <Step number> query is answered, for example, as "1,0.00,0".
'
' (5) Program final line specification
' EOS <Step number> If step number is omitted, data is written in the step of the last step number + 1.
'
' This program takes about 2 minutes till the end of sequence write.
' Example 2 of sequence operation (CV operation, FV mode)
' <<Fast Speed SEQUENCE SAMPLE (Sine wave)>>
Dim VA As Double
Dim PI As Double
Dim V As Double
Dim i As Integer

```

```

Dim loop_count As String
Dim SEQ_NO As String
Dim PROG_NO As String
Dim END_PROG_NO As String
Dim Chain_prog_NO As String
Dim time_set As String

SEQ_NO = "SEQUENCE 1"           ' Specifies SEQUENCE number.
PROG_NO = "1"                   ' Specifies PROGRAM number.
loop_count = "100"              ' Specifies LOOP count.
Chain_prog_NO = "0"             ' Specifies chain program. 0: No chain
END_PROG_NO = "0"               ' 0: No end
time_set = "100uS"              ' Sets FV/FI mode execution time to 100 _s or more.
VA = 20
PI = 3.1415
'----- Mode -----
Call Tx("EXECUTE 0")            ' Exits sequence execution mode.
Call Tx("NEWSEQ 10")           ' Specifies fast sequence [FV] mode.
'----- Sequence -----
Call Tx(SEQ_NO + "," + PROG_NO + "," + loop_count + "," + Chain_prog_NO + "," + END_PROG_NO + "," + time_set) '
'----- Program -----
Call Tx("PROGRAM 1")           ' Specifies PROGRAM 1.

For i = 1 To 1024                ' Writes 1024 steps of data.
  DoEvents
  V = VA / 2 * (Sin(2 * PI * i / 1024) + 1) ' Calculates sine curve voltage data.
  Call Tx("STEP" + Str$(i) + "," + Str$(V) + "," + trg_off) ' Sends STEP data. trg_off="0"
Next
Call Tx("EOS")                  ' Sends EOS.
Call Tx("FSAVE 0@")            ' Saves file.
Call Sequence_RUN               ' Executes sequence.
End Sub

```

[9] Execution of sequence operation

```

Sub Sequence_RUN()
  'Sample program 9 [Sequence execution]
  'This sample program executes a sequence.
  '(1) Program number specification: PROGRAM <1-16> * This can be omitted if the program number has been set immediately before.
  '
  '(2) Sequence execution mode setting
  'EXECUTE <1,0> [1:Execute mode 0:Edit mode]
  'Sequence execution mode query: EXECUTE? query is answered in 1 or 0.
  '
  '(3) Execution/stop/pause
  'RUN <Sequence number 1-8>
  'STOP
  'PAUSE <1,0> [1:ON 0:OFF]
  '
  'Sequence executing status query command: RUNNING?
  'Query is returned as "<STOP:1,RUN:2,PAUSE:3>,<SEQ.NO>,<PROG.NO>,<STEP.NO>".
  '<<Fast Speed SEQUENCE Execute>>

  Dim retVal As Integer
  Call Tx("CLR")                 ' Clears register.
  Call Tx("PROGRAM 1")          ' Specifies PROGRAM 1.
  Call Tx("UNMASK 4")           ' Sets SE bit of unmask register.

```

```

Call Tx("SEQMODE?")
If Val(g_strRxd) > 9 Then
    Call Tx("OUT 1@")
End If
'----- Execute-----
Call Tx("EXECUTE 1")
Call Tx("RUN 1")
'----- SEQUENCE STOP detection----
Do
    DoEvents
    Call Tx("RUNNING?")
    retVal = io.ReadSTB
    Sleep (100)
Loop Until retVal <> 0

Dim spoll_result As String
spoll_result = SRQ_analyze(retVal)
MsgBox spoll_result + vbCrLf + vbCrLf + "SRQ is generated."
Call Tx("EXECUTE 0")
End Sub

```

```

'Sequence mode query
'Fast sequence judgment
'Sends output ON.

'Sends sequence execution mode ON.
'Sends sequence execution.

'Sequence execution status query
'Serial polling
'Delay
'Loops until SRQ rises.

'Calls service request analysis.
'Displays analysis result.
'Sends sequence execution mode OFF.

```

4.7.3 Table of Command Headers

A table of command headers is shown below. The index numbers shown in the table conform with those used in Section 4.3.2 "Structures of Commands."

Header Name	Index No	Header Name	Index No	Header Name	Index No
CLR	[7]	OCPSET	[4]	TEXTPROG	[6]
CTRLZ	[9]	OUT	[1]	TEXTSEQ	[6]
EOS	[6]	OVPACTN	[4]	TRG	[2]
ERR	[10]	OVPSET	[4]	TRIGISET	[2]
EXECUTE	[6]	PATH	[8]	TRIGSTOP	[2]
FAU	[10]	PAUSE	[6]	TRIGVSET	[2]
FLOAD	[6]	PORT	[7]	TRTF	[1]
FSAVE	[6]	POW	[7]	UNMASK	[10]
FUNMASK	[10]	PROGRAM	[6]	VFINE	[1]
HEAD	[10]	RESET	[4]	VOUT	[1]
HOCF	[4]	ROOTPATH	[8]	VSET	[1]
HOVP	[4]	RUN	[6]	WAIT	[7]
IDN	[10]	RUNNING	[6]	<XOFF>	[9]
IFINE	[1]	SEQMODE	[6]	<XON>	[9]
IOUT	[1]	SEQUENCE	[5]		
ISSET	[1]	SETINI	[3]		
LLO	[8],[9]	SETRCL	[3]		
MCBACTN	[4]	SETSTO	[3]		
MEM	[3]	SILENT	[9]		
MEMSTO	[3]	STB	[10]		
MOD	[10]	STEP	[5]		
NEWSEQ	[5]	STOP	[6]		
OCPACTN	[4]	STS	[10]		
OCPDLY	[4]	TERM	[10]		
		TEXTIDX	[6]		

Chapter 5

PANEL DESCRIPTION

This chapter describes the functions of the switches, keys, indicators, and other panel items on the front and rear panels of the power supply.

Contents	Page
5.1 Front Panel	5-2
5.2 Rear Panel	5-6

5.1 Front Panel

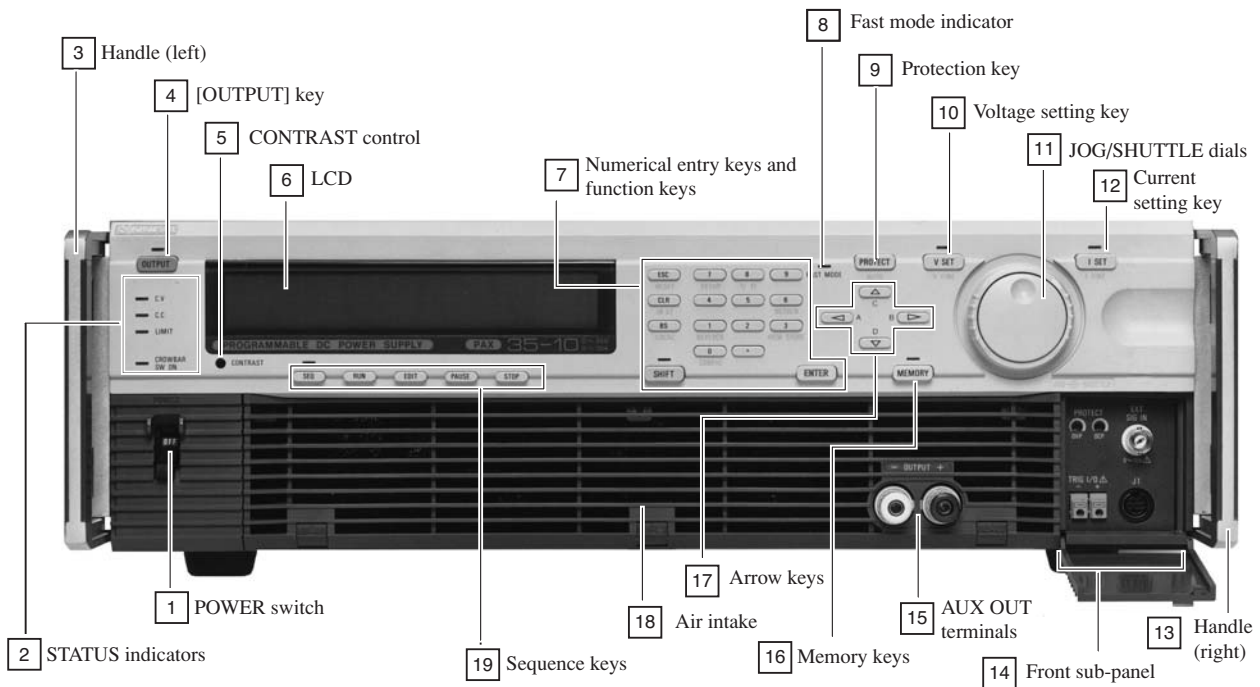

An example of Front Panel of PAX35-10

1 POWER switch

Turns ON/OFF the AC input power of the power supply.

For approximately 2 seconds after the POWER switch is turned ON, the power supply performs self test. During this power-on test period, other functions of the power supply are suppressed.

2 STATUS indicators

Indicate the statuses of the power supply.

CV Illuminates to indicate that the power supply is in the constant-voltage mode.

CC Illuminates to indicate that the power supply is in the constant-current mode.

LIMIT Illuminates to indicate that one of the protectors (OVP, OCP, and OHP) has tripped.

CROWBAR SW ON

Of a power supply which is incorporated with the crowbar option, this indicator illuminates to indicate that the OVP action is set to <Crowbar switch ON>.

3 Handle (left)

4 [OUTPUT] key

Each time as you press this key, the output is turned ON/OFF. When the output is ON, the LED illuminates. When the output is OFF, the output circuit exhibits a high impedance (several killo-ohms).

5 CONTRAST control

Adjusts contrast of the LCD.

6 LCD

A liquid crystal display which shows voltage and current settings, parameters, menus, messages, and other information and data.

7 Numerical entry keys and function keys

These keys are used to enter numeric data and to select menu items and functions.

[ESC]	To cancel the currently proceeding procedure and return to the preceding menu.
[CLR]	To clear the typed value.
[BS]	To clear only one letter that was typed latest.
[9] - [0]	To type a numeric value or to select a menu item.
[.]	To type a decimal point.
[SHIFT]	To be pressed to select the function marked with blue letters below a key. The <SHIFT> LED will illuminate when the shift is effected.
[ENTER]	To enter the typed value.

Table of blue-letter functions

RESET ([SHIFT]+[ESC])

To reset from the error status or alarm status.

IBST ([SHIFT]+[CLR])

To display the GPIB status.

LOCAL ([SHIFT]+[BS])

To return to the LOCAL mode from the interfaced remote mode.

Tr Tf ([SHIFT]+[8])

To select Tr Tf in CV or CC mode (for Fast mode only).

SETUP ([SHIFT]+[7])

To display a setup file menu.

RESOLN ([SHIFT]+[6])

To set a click resolution for [V SET] or [I SET] (setting with JOG dial or [▲] [▼] keys). If selected when in [V SET] mode, the [V SET] resolution can be set; if selected when in [I SET] mode, the [I SET] resolution can be set. The range of resolution is from 0.001 to about one-half of the rated voltage or current.

MEM STORE ([SHIFT]+[3])

To store the currently existing setup data (a pair of voltage and current) onto memory area [A], [B], [C], or [D].

Example: [SHIFT]+[6] MEM STORE +[A] is for store onto memory A.

KEYLOCK ([SHIFT]+[1])

To lock the keys on the front panel. The locked keys can be released by pressing the [SHIFT]+[1] KEYLOCK keys.

CONFIG ([SHIFT]+[0])

To call out the configuration menu for setting the conditions the power supply should assume when its POWER switch is turned on.

8 Fast mode indicator

Illuminates to indicate that the power supply is the Fast speed mode.

9 Protection key

[PROTECT] To set the software OVP or software OCP, and to select the actions to be done when OVP or OCP has tripped. Also to check the set limit of hardware OVP or hardware OCP.

AUTO ([SHIFT]+[PROTECT])

For automatic setting of software OVP and software OCP limit in percentage. The percentages are selectable on the configuration menu.

10 Voltage setting key

[V SET] To select the output voltage setting mode (the LED illuminates to indicate the mode). The value can be set with the numeric entry keys, JOG and SHUTTLE dials, or [▲] [▼] keys.

V FINE ([SHIFT]+[V SET])

To select the Fine output voltage setting mode. The value can be set with the JOG/SHUTTLE dials.

11 JOG/SHUTTLE dials

To change numeric values or to scroll menus.

12 Current setting key

[I SET] To select the current setting mode (the LED illuminates to indicate the mode). The value can be set with the numeric entry keys, JOG and SHUTTLE dials, or [▲] [▼] keys.

I FINE ([SHIFT]+[I SET])

To select the Fine output current setting mode. The value can be set with the JOG/SHUTTLE dials.

13 Handle (right)

14 Front sub-panel

Accommodates the following controls and connectors:

PROTECT

OVP Potentiometer for hardware OVP setting

OCP Potentiometer for hardware OCP setting

TRIG I/O Terminal for trigger signal input/output

EXT SIG IN Terminal of external signal input for analog remote control

J1 Terminal to hook up the dedicated-type remote controller (optional)

Caution

- Before connecting wires to or disconnecting wires from the terminals, be certain that the POWER switch is OFF.

15 AUX OUT terminals

The auxiliary output terminals on the front panel are provided only for the models whose rated output current is not greater than 30A.

The rated output current of the power supply is the sum of the current that is delivered through these terminals plus that delivered through those output terminals on the rear panel.

NOTE

- *The performance specifications is not applicable to these auxiliary output terminals on the front panel.*

16 Memory keys

[MEMORY] The setup (a pair of voltage setting and current setting) can be recalled from the memory with the [A], [B], [C] or [D] key or with the JOG dial and the [ENTER] key. When in the memory recall mode, the LED illuminates.

17 Arrow keys

To increment/decrement a numerical value or to scroll a menu.

18 Air intake

To intake cooling air.

Caution

- *Periodically clean the air filter.*
- *Pay attention so that the air intake is not blocked.*

19 Sequence keys

To edit sequence files and to control sequence actions.

[SEQ]	Selects the sequence mode. The LED illuminates to indicate the sequence mode.
[RUN]	Executes the selected sequence file.
[EDIT]	To edit the sequence file.
[PAUSE]	To pause the sequence file being executed or to resume the paused sequence.
[STOP]	To stop the sequence that is being executed or has been paused.

5.2 Rear Panel

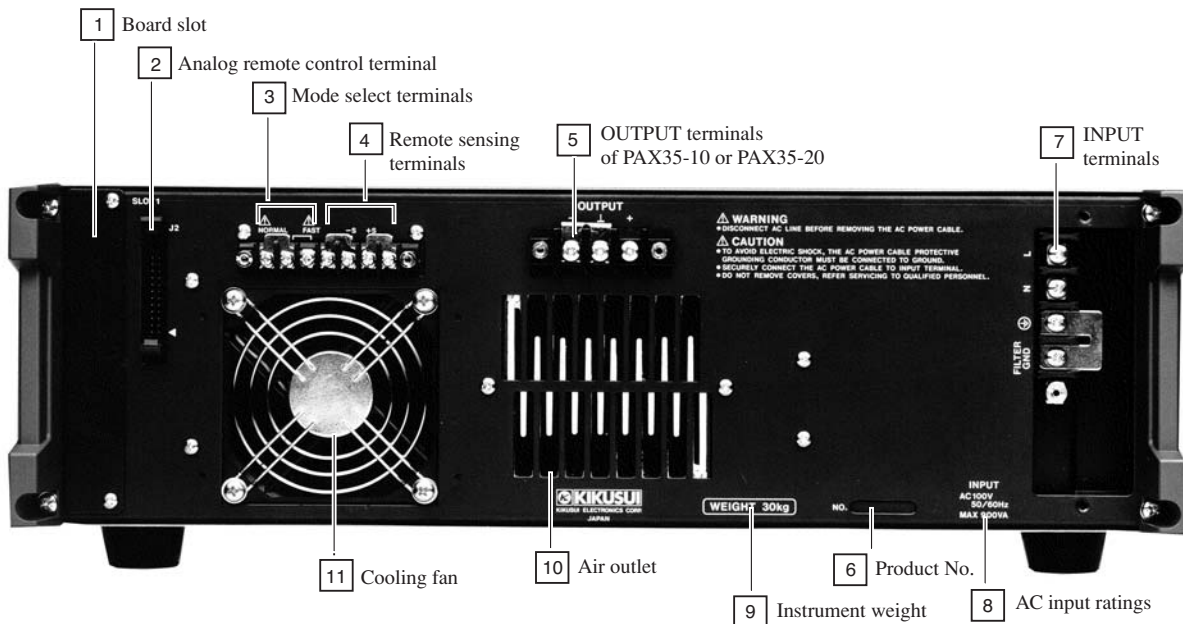

Note: Items 2, 3, 4, 5 and 7 are as they appear when their covers are removed.

An example of Front Panel of PAX35-10

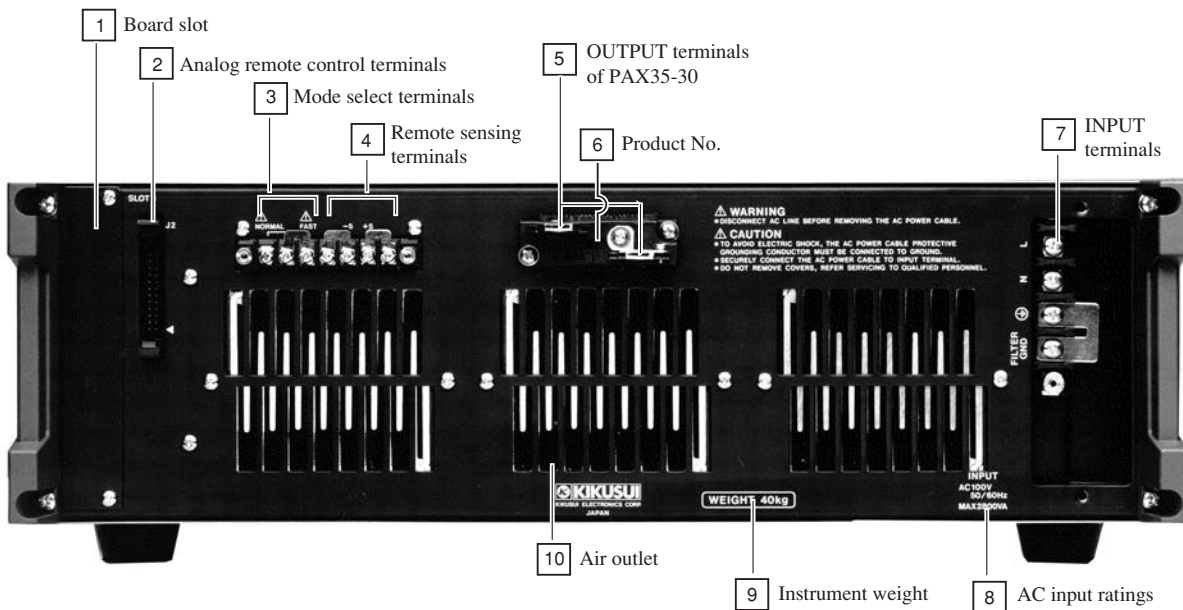

Note: Items 2, 3, 4, 5 and 7 are as they appear when their covers are removed.

An example of Front Panel of PAX35-30

1 Board slot

To install one of the following three types of optional interface board.

- IB11 (GPIB interface board)
- RS11 (RS-232C interface board)
- MC11S (MCB interface board)

Caution

- Before inserting/removing an interface board or connecting/disconnecting the cables, be certain that the POWER switch has been turned OFF.

2 Analog remote control terminals

This terminal is for remote control of the output with an external analog signal.

The functions served by this terminal are as follows:

- Output voltage control with a voltage signal
- Output voltage control with a resistance signal
- Output current control with a voltage signal
- Output current control with a resistance signal
- Output ON/OFF-control
- Shut down of POWER switch
- Delivery of CV monitor signal
- Delivery of CC monitor signal
- Delivery of status monitor signals

Caution

- *Before connecting/disconnecting the connectors or cables, be certain that the POWER switch has been turned OFF.*
- *Be certain that the terminal cover has been put on. Do not operate the power supply with the terminal cover removed.*

3 Mode select terminals

To select either the Fast speed mode or the Normal speed mode by changing the short piece to the corresponding position.

Caution

- *Before changing the short piece, be certain that the POWER switch has been turned OFF.*
- *Be certain that the terminal cover has been put on. Do not operate the power supply with the terminal cover removed.*

4 Remote sensing terminals

To connect the remote sensing wires. The remote sensing is to compensate for voltage drops that are caused by the load-connection wiring resistances and contact resistances.

Caution

- *Be sure to securely connect the sensing wires. Note that, if the sensing circuit is made open, an abnormal voltage may develop in the power supply and its load may be damaged.*
- *Be certain that the terminal cover has been put on. Do not operate the power supply with the terminal cover removed.*

5 OUTPUT terminals

Delivers the output of the power supply. Normally, connect the "+" or "-" output terminal to the chassis ground. Note that, if none of them is grounded, the performance of the power supply may not meet the specifications.

WARNINGS

- *Be certain that the terminal cover has been put on. Do not operate the power supply with its terminal cover removed.*

6 Product No.

Indicates the serial number of the power supply.

7 INPUT terminals

The terminals of the AC input power circuit of the power supply.

L	Live
N	Neutral
GND	Ground
FILTER GND	Noise filter ground

WARNINGS

- *In order to prevent electric shock hazards, be sure to ground the GND terminal of the power supply by connecting to it the GND wire (green) of the AC input power cable which accompanies the power supply.*
- *Unless the power supply is grounded, electric shock hazards can result. Make it double sure that the power supply is securely grounded.*
- *Do not touch the AC power input terminals.*
- *The task of connecting the AC input power cable to the power supply and to a power distribution panel involves danger. The task must be undertaken only by qualified electronics personnel.*
- *Be certain that the terminal cover has been put on. Do not operate the power supply with its terminal cover removed.*

8 AC input ratings**9 Instrument weight****10 Air outlet**

An outlet of cooling air. Note that hot exhaust air (room temperature + up to approximately 40°C) comes of the outlet.

Caution

- *Do not touch the air outlet. Do not block the hot air flow that comes out of the outlet.*
- *The exhaust air temperature may become high (room temperature + up to approximately 40°C) depending on the load. Do not put behind the power supply any objects which are not heat resistant.*

11 Cooling fan

Chapter 6

MAINTENANCE

AND CALIBRATION

This chapter elaborates the maintenance, inspection, and calibration methods of the power supply.

Contents	Page
6.1 Maintenance and Inspection	6-2
6.2 Calibration	6-4
6.2.1 Preparation	6-4
6.2.2 Calibration Instruments	6-4
6.2.3 Calibration Setups	6-4
6.2.4 Calibration Procedures	6-5

It is most recommendable to render maintenance and calibration service for the power supply at certain scheduled intervals.

6.1 Maintenance and Inspection

WARNINGS

- Before starting maintenance service for the power supply, be sure to disconnect its AC input power cable from its power source (AC line outlet or distribution panel).

(A) Cleaning the front panel and dust filter

(a) Cleaning the front panel

To clean the front panel, wipe it lightly with a soft cloth moistened with thin neutral soapsuds.

Caution

- Do not use benzine, thinner, or other detergent. Detergent may cause discoloration of the panel surface, erasure of printed characters and marks, and clouding of the display screen.

(b) Cleaning the dust filter

If the filter is clogged with dust, the cooling efficiency will be degraded and troubles may result or the life of the power supply may be shortened. It is most recommendable to clean the filter periodically at certain scheduled intervals. To take out the filter to clean it, remove the louver as shown below.

- Removing the louver

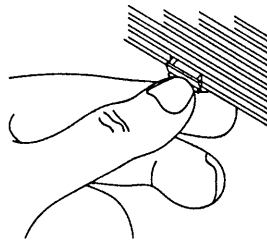

Push down the three nails.

- Installing the louver

Put back the louver by mating its top protrusions into the indents of the power supply, and fix the louver by pushing up the three nails.

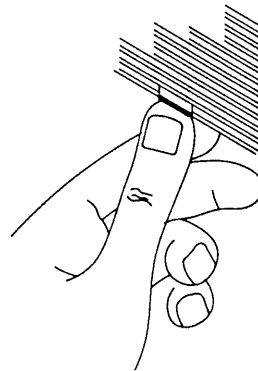
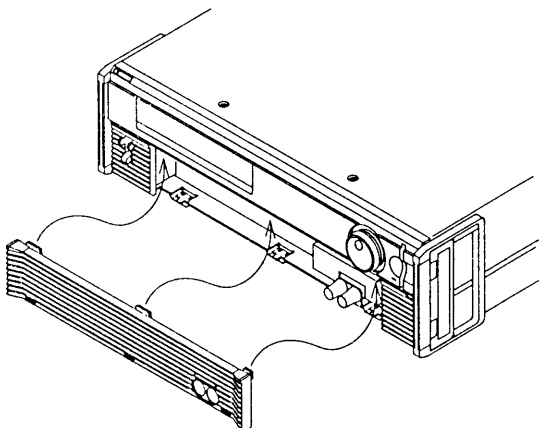

(B) Inspecting the AC input power cable

Inspect the AC input power cable for any signs of abnormality. Check that its sheath is not damaged, and that its plug is not cracked and has no loose screws.

(C) Order for overhaul

Certain internal components (such as electrolytic capacitors and cooling fan motor) of the power supply are wearable components and should be replaced when a certain period has elapsed. The period typically is 10,000 running hours, although it differs depending on the conditions of use of the power supply. You are recommended to order, when such period has elapsed, your Kikusui agent for overhaul of your power supply.

WARNINGS

- *Before cleaning or moving the power supply, be certain that its AC input power cable has been disconnected from its power source (AC line outlet or distribution panel).*
- *Never open the casing of the power supply.*

6.2 Calibration

The power supply is calibrated before shipment by the vendor warranting that it meets its performance specifications. Later, however, due to changes in environments and due to aging by a long run of use, the supply may become unable to meet the specified setting accuracies of the output voltage, output current, OVP, and OCP. When this is the case, calibrate the power supply following the instructions given in this section.

6.2.1 Preparation

Before start calibrating the power supply, allow a stabilization period (warm up period with the POWER switch ON) of 20 minutes or more. This will eliminate the calibration errors that could be caused by initial drifts.

Before start calibrating the power supply, turn the OVP and OCP potentiometers on the front panel to their full clockwise positions. Return them to the required positions after the calibration is over.

6.2.2 Calibration Instruments

To calibrate the power supply, you need the following instruments:

- DC voltmeter (DVM), accuracy 0.02% or better
- Shunt resistor, accuracy 0.1% or better

6.2.3 Calibration Setups

The calibration setup differ between voltage calibration and current calibration as shown below.

(a) Voltage calibration

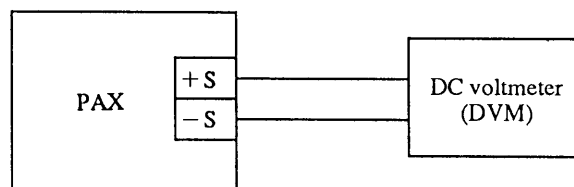

(b) Current calibration

The current can be known by calculation from the voltage developed across the shunt resistor.

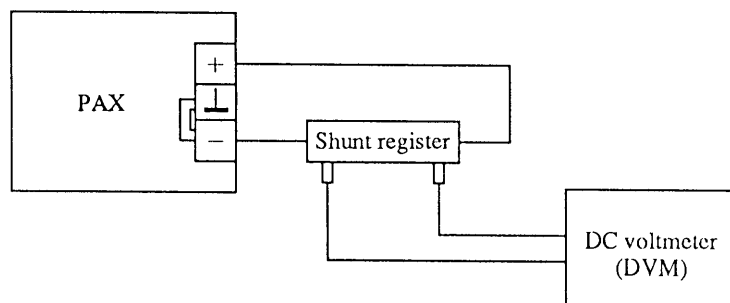

Caution

- For the calibration setup wiring, use wires of sufficiently large current ratings.
 - You may use the Fast mode to speed up the automatic OVP calibration process-
- ing.

6.2.4 Calibration Procedures

This section describes the calibration procedures, taking the PAX35-20 as an example.

Caution

- *When calibrating your power supply, observe strictly the instructions given below. If you do not, your power supply may not meet the performance specifications.*

(A) Voltage Calibration

The items which are subject to voltage calibration are as follows:

- Offset voltage
- Full scale voltage
- Software OVP offset voltage
- Software OVP full-scale voltage
- Hardware OVP offset voltage
- Hardware OVP full-scale voltage

Calibration of OVP is automatically done by using the calibration values of offset voltage and full-scale voltage. Thus, calibration of offset voltage and that of full-scale voltage only are needed for voltage calibration.

For offset voltage calibration, adjust so that the output voltage becomes 0.000V. For full-scale voltage calibration, enter the readback value of the actual output voltage with the numeric entry keys.

Example of voltage calibration

- ① Press the **[SHIFT] + [0] CONFIG, [9]** keys in this order to select [calibration].

```
>9: Calibration
   ID Code ?   3520
```

- Enter a calibration ID code of 4 digits with the numeric entry keys.
- For the calibration ID codes, refer to Appendix 6 "Table of ID Codes."



```
>1: Voltage
   2: Current
```

- The display indicates the calibration mode.
- Check the connections when in this state.

- ② Press the **[1]** key to select the voltage calibration mode.

```
Start Calibration
Ready ?
```

- ③ After checking the connections, press the **[ENTER]** key to start voltage calibration (offset voltage calibration in this example).

With the JOG dial, adjust the DVM reading to within the offset voltage calibration value range.

```
Adjust to 0V
Ready ?
```

- The output voltage is 0V.
- For the offset voltage calibration values, refer to Appendix 6 "Offset Calibration Values."

- ④ Press the **[ENTER]** key to terminate the offset voltage calibration.
Next, calibrate the full scale voltage.

```
Reading Voltage ?
      V
```

- The output voltage is approximately 100% of the rated output voltage.

- ⑤ Enter the DVM reading with the numeric entry keys. For example, press the **[3]**, **[4]**, **[.]**, **[6]**, **[9]**, **[2]**, and **[ENTER]** keys in this order.

```
Reading Voltage ?
      34.692V
```



```
OVP Calibrating
```

- Automatic execution of software and hardware OVP calibration



When about two seconds has elapsed

```
Save Data
Sure ?
```

- The voltage calibration is over. The calibration value will be stored onto the non-volatile memory.
- The calibration value will not be stored if you press the **[ESC]** key.

- ⑥ Press the **[ENTER]** key to store the calibration value.

```
>1: Voltage
  2: Current
```

(B) Current Calibration

The items which are subject to current calibration are as follows:

- Offset current
- Full scale current
- Software OCP offset current
- Software OCP full-scale current
- Hardware OCP offset current
- Hardware OCP full-scale current

Calibration of software OCP is automatically done by using the calibration values of offset current and full-scale current.

For offset current calibration, adjust so that the output current becomes 0.000A. For full-scale current calibration, enter the readback value (converted value) of the actual output current with the numeric entry keys.

For calibration of hardware OCP offset current and hardware OCP full scale current, adjust the OCP potentiometer on the front sub-panel in conformity with the value indicated on the front panel display.

Example of current calibration

① Press the **[SHIFT] + [0] CONFIG, [9]** keys in this order to select [calibration].

```
>9: Calibration
   ID Code ?   3520
```

- Enter a calibration ID code of 4 digits with the numeric entry keys.
- For the calibration ID codes, refer to Appendix 6 "Table of ID Codes."



```
>1: Voltage
   2: Current
```

- If you are going to do a current calibration following a voltage calibration, start it with this state.
- Check the connections when in this state.

② Press the **[2]** key to select the current calibration mode.

```
Start Calibration
Ready ?
```

③ After checking the connections, press the **[ENTER]** key to start current calibration (offset current calibration in this example). With the JOG dial, adjust the output current to within the offset current calibration value range.

```
Adjust to 0A
Ready ?
```

- The output current is 0A.
- For the offset current calibration values, refer to Appendix 6 "Offset Calibration Values."

- ④ Press the **[ENTER]** key to terminate the offset current calibration.
Next, calibrate the full scale current.

Reading Current ?
A

- The output current is approximately 100% of the rated output current.

- ⑤ Wait until the voltage detected by the shunt resistor is stabilized.
Then enter the DVM reading with the numeric entry keys. For example, press the **[1]**, **[9]**, **[.]**, **[6]**, **[8]**, **[3]**, and **[ENTER]** keys in this order.

Reading Current
19.683A

- Conversion formula

$$\text{Actual current} = \text{DVM reading} \times \frac{\text{Rated current of shunt resistor}}{\text{Rated voltage drop across shunt resistor}}$$



OCP Calibrating

- Execution of software OCP



When about two seconds has elapsed

Turn round VR. ←CCW←

- ⑥ Next, calibrate the hardware OCP offset current by turning the OCP potentiometer.

Turn round VR. ←CCW←

- Turn the OCP potentiometer counter clockwise.

Turn round VR. →CW→

- Turn the OCP potentiometer clockwise.

Turn round VR. =OK=

- The OCP potentiometer is within the valid calibration range.

- ⑦ When [=OK=] is displayed, set the potentiometer at that position and press the **[ENTER]** key. Next, perform hardware OCP full-scale calibration.

Turn round VR. ←CCW←

- Turn the OCP potentiometer counter-clockwise.

Turn round VR. →CW→

- Turn the OCP potentiometer clockwise.

Turn round VR. =OK=

- The OCP potentiometer is within the valid calibration range.

- ⑧ When [=OK=] is displayed, set the potentiometer at that position and press the **[ENTER]** key.

OCP Calibrating

- Automatic execution of software and hardware OCP calibration

▼ When about two seconds has elapsed

Save Data
Sure ?

- The current calibration is over. The calibration value will be stored onto the non-volatile memory.
- The calibration value will not be stored if you press the **[ESC]** key.

- ⑨ Press the **[ENTER]** key to store the calibration value.

>2: Current
1: Voltage

- ⑩ Press the **[ESC]** key twice.

OUT 0.001V - 0.01A

- The root display will resume.

Chapter 7

SPECIFICATIONS

This chapter provides tables of electrical specifications, mechanical specifications, accessories, and optional items.

Contents	Page
7.1 Electrical Specifications	7-2
7.2 Dimensions and Weights	7-11
7.3 Accessories	7-12
7.4 Optional Items	7-13

7.1 Electrical Specifications

- Unless otherwise specified, the following conditions are assumed for the specifications:
 - The loads are resistive.
 - The remote sensing function is not employed.
 - The "-" output terminal is connected to the chassis ground terminal by using the short piece that accompanies the power supply.
- The "typ" values (typical values) are only for information. They are not included in the warranted electrical performance specifications of the power supply.
- The AUX OUT terminals do not meet the warranted electrical performance specifications of the power supply.

Item		PAX35-10	PAX35-20	PAX35-30	Unit		
AC line requirements	Voltage and frequency	100V ±10%, 50/60 Hz, 1 φ (110, 120, 200, 220, 240V are factory options.)					
	Input current (at 100V, with full load)	8.5A	17.5A	25A			
	Inrush current *1	13A (at V(in) =AC110V)					
Output setting	Voltage setting	Setting range	0 - 35.00	0 - 35.00	0 - 35.00	V	
		Resolution	1	1	1	mV	
	Output voltage	Output accuracy *2	±40	±40	±40	mV typ.	
		Temperature coefficient	100 (35 typ.)			ppm/°C	
	Current setting	Setting range	0 - 10.00	0 - 20.00	0 - 30.00	A	
		Resolution	1	1	1	mA	
	Output current	Output accuracy *2	±40	±60	±90	mA typ.	
		Temperature coefficient	150 (50 typ.)			ppm/°C	
Display	Digital meter	Output voltage	Display accuracy *3	0.07%+10	0.07%+10	0.07%+10	mV typ.
			Temperature coefficient	100			ppm/°C typ.
	Output current	Display accuracy *3	0.3%+30	0.3%+30	0.3%+40	mA typ.	
		Temperature coefficient	150			ppm/°C typ.	

*1: The supply can be operated from a nominal 110V, 120V, 200V, 220V or 240V single-phase ac power source with addition of factory options.

Input current

Item		PAX35-10	PAX35-20	PAX35-30
Input voltage 50/60 Hz	110V	7.7A	15.9A	22.7A
	120V	7.1A	14.6A	20.8A
	200V	4.3A	8.8A	12.5A
	220V	3.9A	8.0A	11.4A
	240V	3.5A	7.3A	10.4A

Inrush current

110V:14.3A, 120V:15.6A, 200V:25.9A, 220V:28.5A, 240V:31.1A (These are common specification.)

$\text{Inrush current} \leq (\text{Nominal voltage} \times \sqrt{2} \times 1.1) \div 12$

(Inrush current: The transient current that the power supply draws from the AC line within 2 seconds after the POWER switch is turned on)

*2: Accuracy of the output voltage with respect to the setting, at a temperatures within ±5°C of that when at calibration, (excluding the measuring errors when at calibration and when at evaluation)

*3: Accuracy of the displayed value with respect to the output, at a temperatures within ±5°C of that when at calibration, as expressed in terms of ±(□□% + □□), (excluding the measuring errors when at calibration and when at evaluation)

Item		PAX35-10	PAX35-20	PAX35-30	Unit			
CV characteristics	Normal mode	Ripple	RMS *4	0.2	0.4	0.4	mV(RMS)	
			P-P *5	3	3	3	mV(P-P) typ.	
		Load effect	*6	1	2	2	mV	
		Source effect	*7	1	1	1	mV	
		Transiential response	*8	50	50	50	μ s typ.	
		Rise up	*9	50			ms typ.	
		Fall down	*10	50			ms typ.	
	Fast mode	Ripple	RMS *4	2	2	3	mV(RMS)	
			P-P *5	10	10	10	mV(P-P) typ.	
		Load effect	*6	1	2	2	mV	
		Source effect	*7	1	1	1	mV	
		Transiential response	*8	100	150	200	μ s typ.	
		Rise up	*9	50 μ s	50			μ s typ.
				500 μ s	500			μ s typ.
				5ms	5			ms typ.
		Fall down	*10	50 μ s	50			μ s typ.
				500 μ s	500			μ s typ.
				5ms	5			ms typ.

*4: 5Hz to 1MHz, (at output terminals on rear panel)

*5: DC to 20MHz, (at output terminals on rear panel)

*6: Against 0 to 100% change of output current, (at remote sensing terminals)

*7: Against $\pm 10\%$ change of AC input voltage, (at remote sensing terminals)

*8: Period the output voltage takes to recover to its original voltage with a tolerance of "(0.05% of rated output voltage) + 10mV" in response to stepwise output current change of from 10% to 100% or from 100% to 10%, (at remote sensing terminals)

*9: Period the output voltage takes to rise up from 10% to 90% of the rated output voltage in response to output voltage setting change from 0 to the rated value.

*10: Period the output voltage takes to fall down from 90% to 10% of the rated output voltage in response to output voltage setting change from the rated value to 0.

Item		PAX35-10	PAX35-20	PAX35-30	Unit			
CC characteristics	Normal mode	Ripple	RMS *11	2	2	3	mA(RMS)	
			Load effect	*12	7	7	7	mA
		Source effect	*13	1	2	3	mA	
		Rise up	*14	50			ms typ.	
		Fall down	*15	50			ms typ.	
	Fast mode	Ripple	RMS *11	3	6	10	mA(RMS)	
			Load effect	*12	10	10	10	mA
		Source effect	*13	1	2	3	mA	
		Rise up	*14	50 μ s	50			μ s typ.
				500 μ s	500			μ s typ.
				5ms	5			ms typ.
		Fall down	*15	50 μ s	50			μ s typ.
				500 μ s	500			μ s typ.
				5ms	5			ms typ.

*11: 5Hz to 1MHz

*12: Against 10 to 100% change of output voltage

*13: Against $\pm 10\%$ change of AC input voltage

*14: Period the output current takes to rise up from 10% to 90% of the rated output current in response to output current setting change from 0 to the rated value.

*15: Period the output current takes to fall down from 90% to 10% of the rated output current in response to output current setting change from the rated value to 0.

Item		PAX35-10	PAX35-20	PAX35-30	Unit	
Protections	Software OVP	Setting range	3.5 - 38.5	3.5 - 38.5	3.5 - 38.5	V
		Trip accuracy *16 set value \pm	0.4	0.4	0.4	V typ.
		Temperature coefficient	200			ppm/°C typ.
	Software OCP	Setting range	1-11	2-22	3 - 33	A
		Trip accuracy *16 set value \pm	0.2	0.4	0.6	A typ.
		Temperature coefficient	300			ppm/°C typ.
	OCP delay time	Setting range	0.05~9.99 (0.01sec. Step)			sec
		Timing accuracy set value \pm	0.05			sec typ.
	Hardware OVP	Setting range	3.5 - 38.5	3.5 - 38.5	3.5 - 38.5	V
		Trip accuracy *16 set value \pm	0.4	0.4	0.4	V typ.
		Temperature coefficient	400			ppm/°C typ.
	Hardware OCP	Setting range	1-11	2-22	3 - 33	A
		Trip accuracy *16 set value \pm	0.2	0.4	0.6	A typ.
		Temperature coefficient	500			ppm/°C typ.
	Trigger	Input	Voltage	5 - 6 V / 10 m A		
Pulse width			≥ 100 ms			
Output		Output impedance	Approx. 15k Ω			(floating output)
		Pulse	Approx. 2.5V / 10 μ s			
Insulation resistance and Withstanding voltages	Insulation resistance	Input to chassis	≥ 30 M Ω , with 500VDC			
		Output to chassis	≥ 20 M Ω , with 500VDC			
	Withstanding voltages	Input to output	1500V AC , for 60 sec			
		Input to chassis	1500V AC , for 60 sec			
Ambient conditions	Operating temperature range		0 to + 40°C (32 to 104°F)			
	Operating humidity range *17		30 to + 80% RH			
	Storage temperature		-20 to + 70°C (-4 to 158°F)			
	Storage humidity *17		20 to + 80% RH			

*16: Accuracy of trip point of the protector with respect to the set point, at a temperatures within $\pm 5^{\circ}\text{C}$ ($\pm 9^{\circ}\text{F}$) of that when at calibration, (excluding the measuring errors when at calibration and when at evaluation)

*17: There shall be no condensation

Input current vs. output voltage characteristics (typical)

Input voltage AC 100V

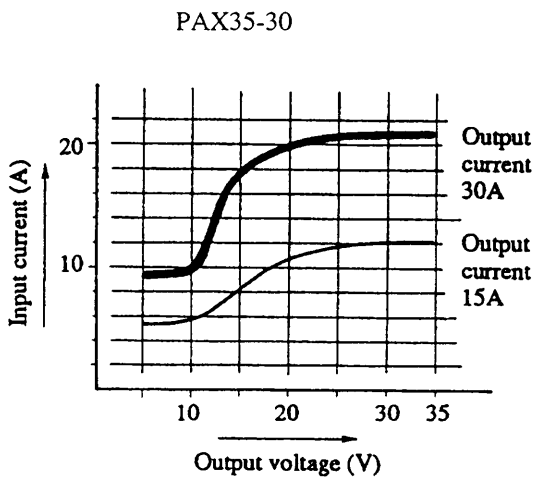
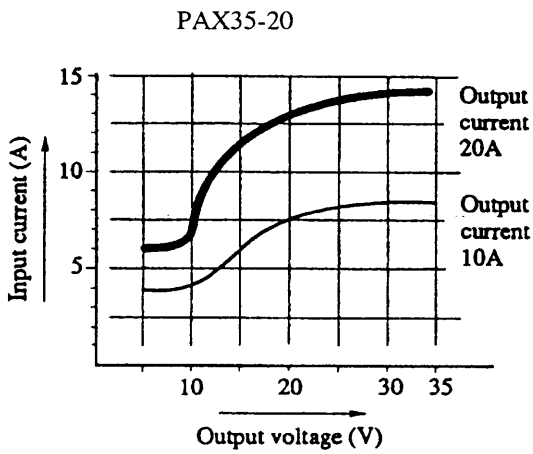
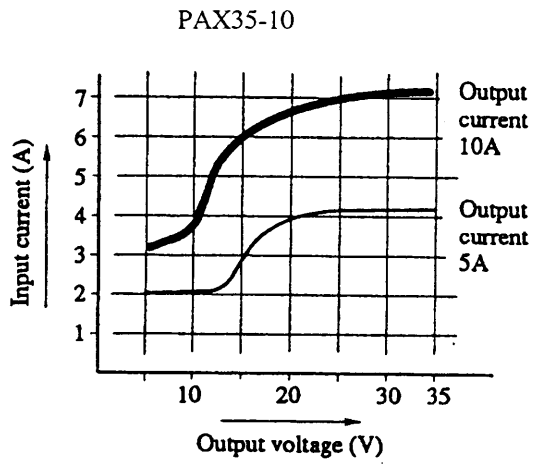

Input current vs. output voltage characteristics (typical)

Input voltage AC 110V

PAX35-10

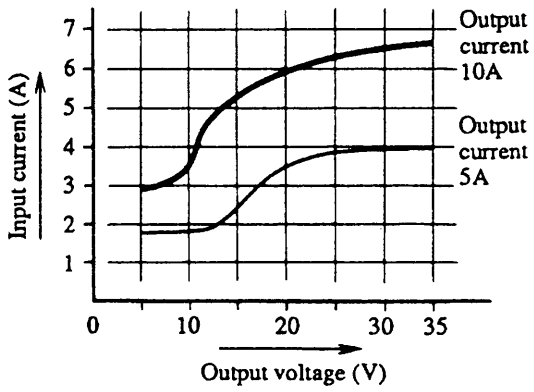

PAX35-20

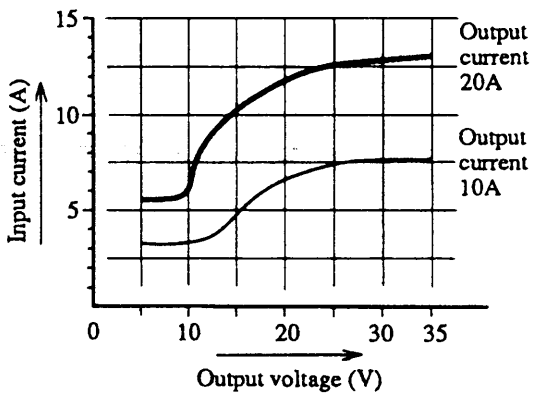

PAX35-30

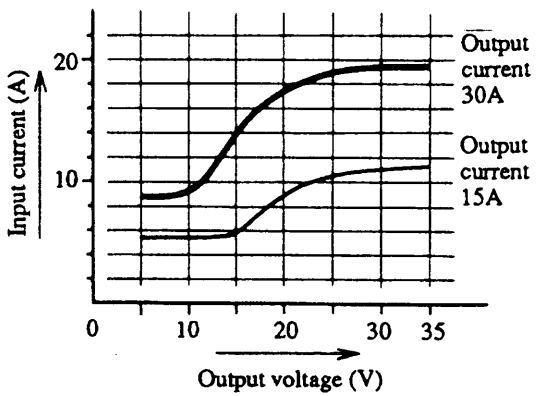

Input current vs. output voltage characteristics (typical)

Input voltage AC 120V

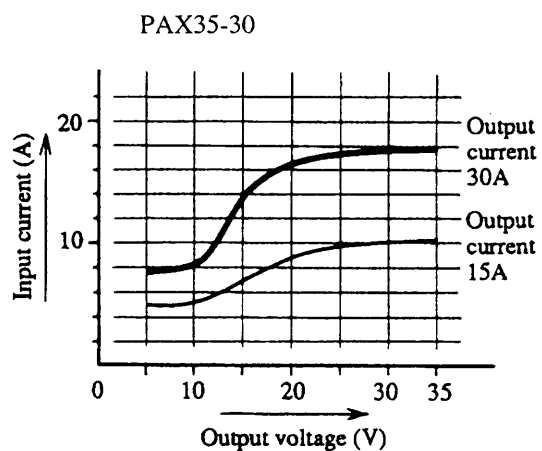
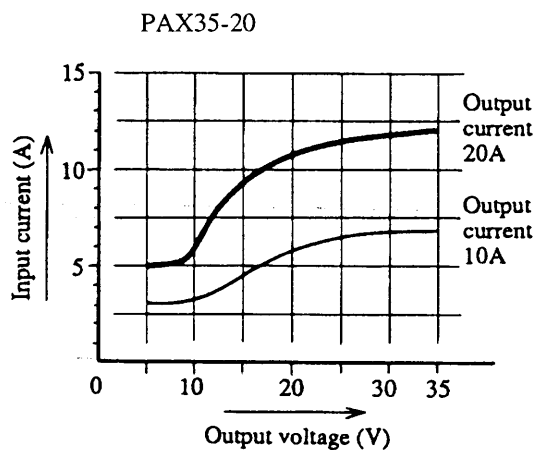
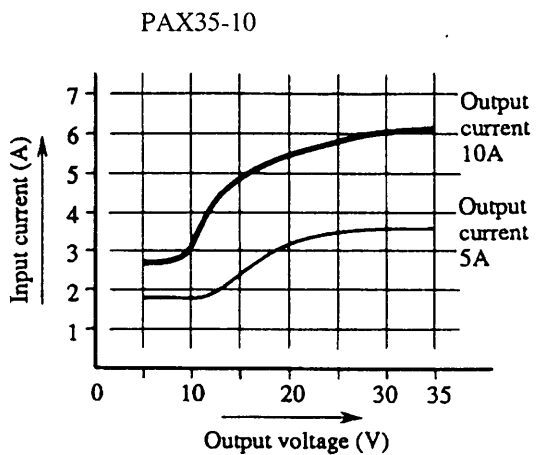

Input current vs. output voltage characteristics (typical)

Input voltage AC 200V

PAX35-10

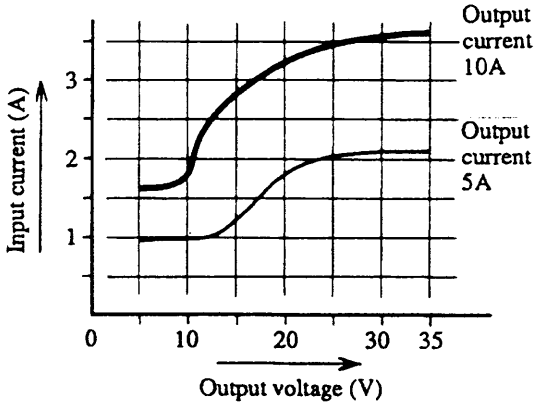

PAX35-20

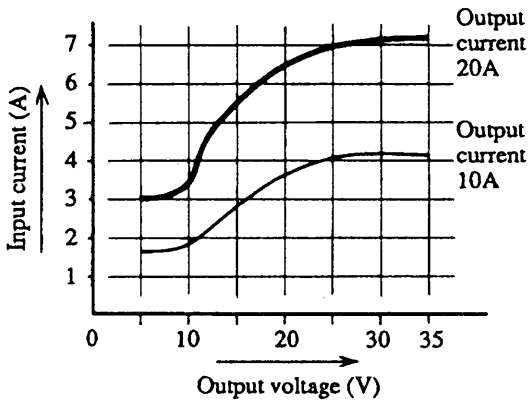

PAX35-30

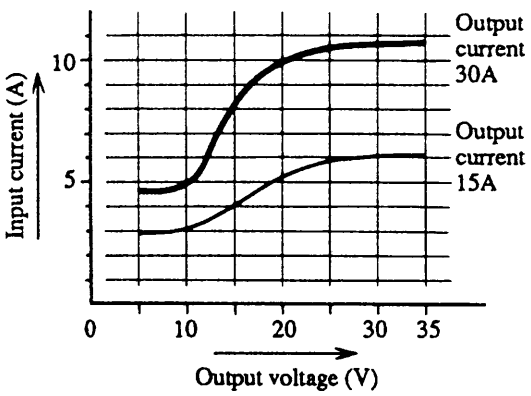

Input current vs. output voltage characteristics (typical)

Input voltage AC 220V

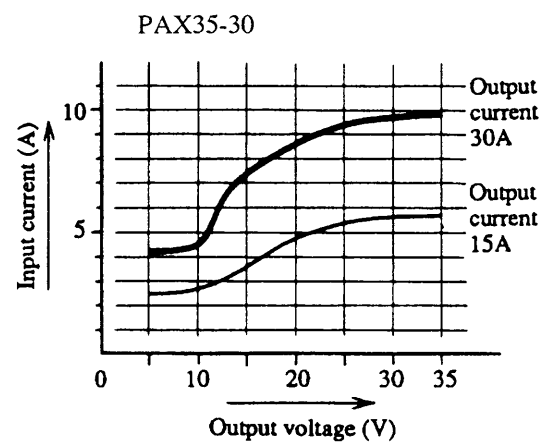
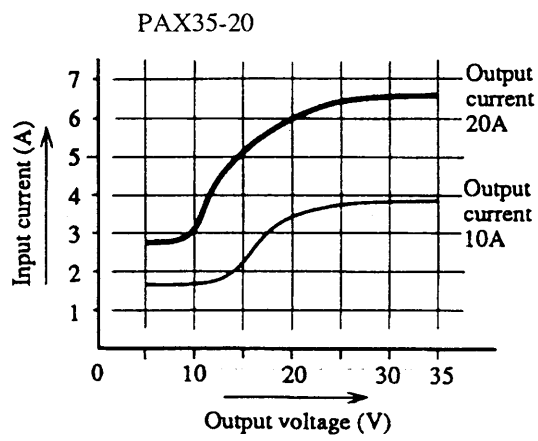
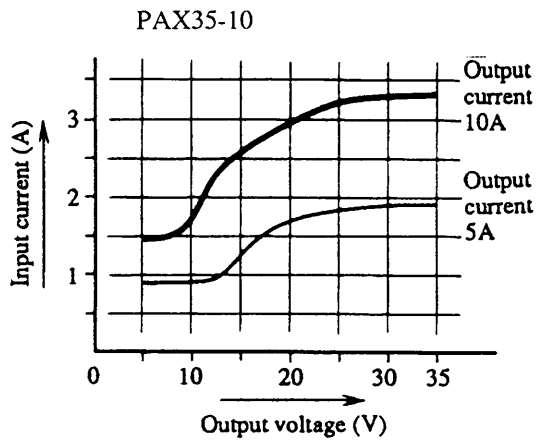

Input current vs. output voltage characteristics (typical)

Input voltage AC 240V

PAX35-10

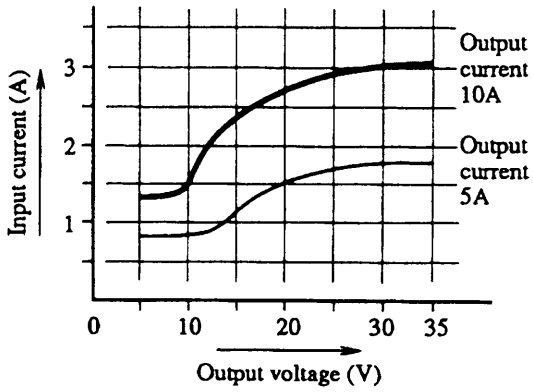

PAX35-20

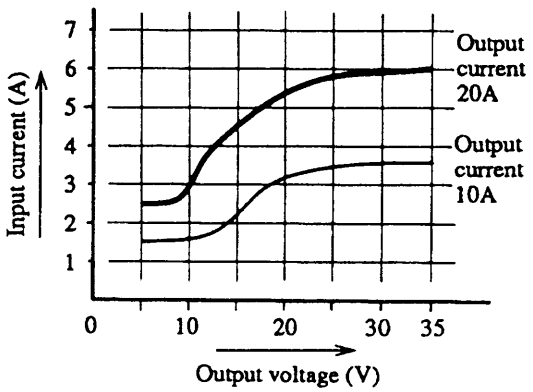

PAX35-30

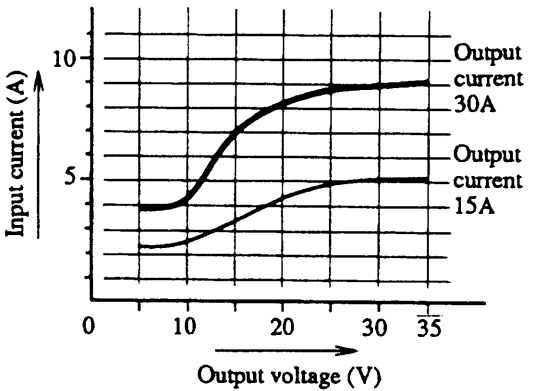

7.2 Dimensions and Weights

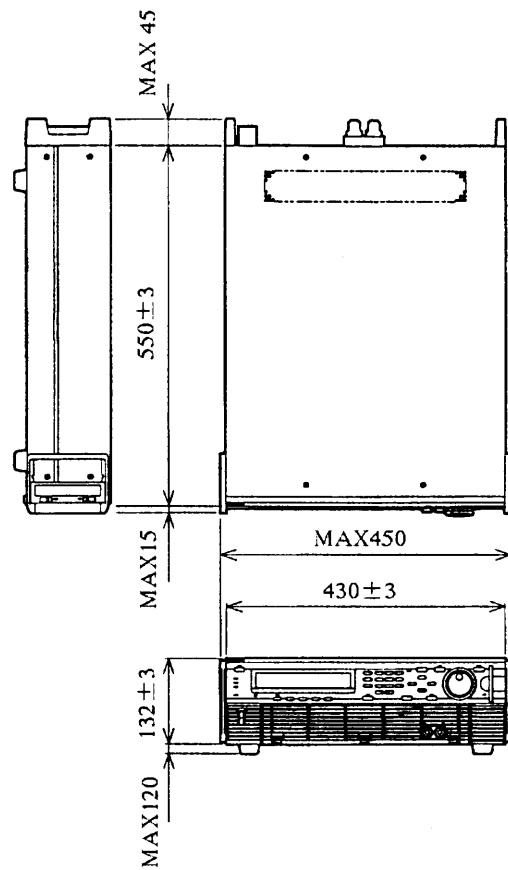

- PAX35-20 *1 Approx. 33kg
- PAX35-30 Approx. 40kg

unit : mm

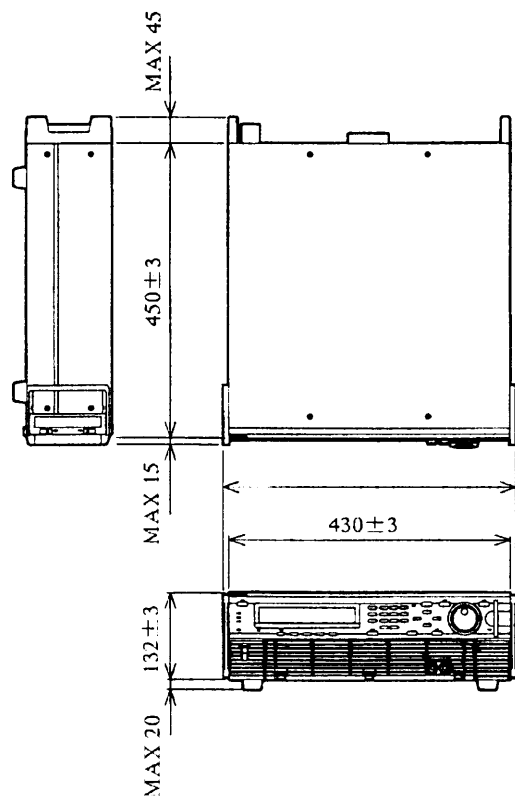

- PAX35-10 *1 Approx. 26kg

unit : mm

*1: The output terminals of these models are of a screw binding™ post type. (Those of other models are of a bar terminal type.)

7.3 Accessories

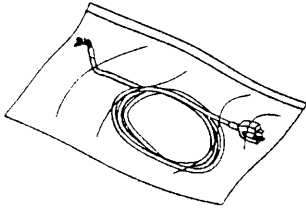

- AC input power cable (1)

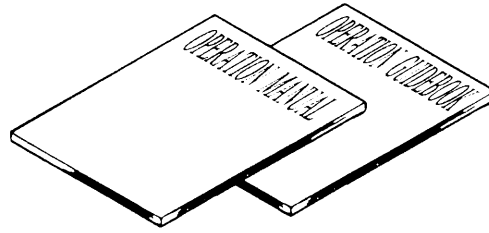

- Operation manual (1 copy)
- Sequence operation guidebook (1 copy)



- Terminals for analog remote control (20)

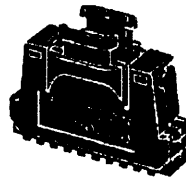

- Hood cover (1 set)

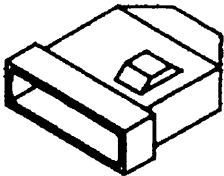

- Output terminal cover (1)
- Seals (2 sheets)

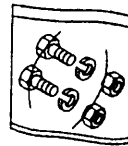

- Output terminal connection bolts (2)
- Nuts (2)
- Spring washers (2)

NOTE

- *The output terminal cover, bolts, nuts, and spring washers are supplied for Model PAX35-30 only.*

7.4 Optional Items

Exclusive Remote Controller

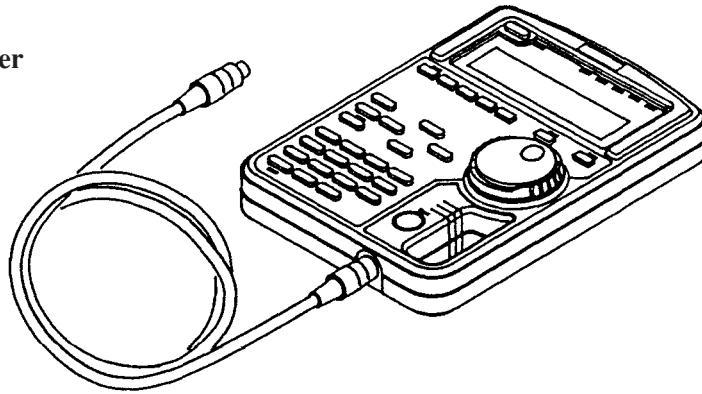

RC02-PAX

Interface Boards

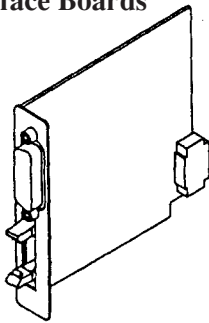

IB11
(GPIB)

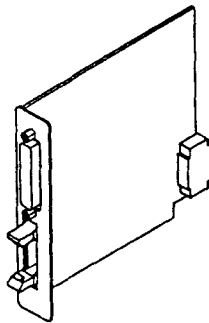

RS11
(RS-232C)

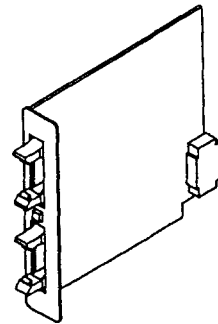

MC11S
(MCB: Multichannel bus)

Rack Mount Brackets

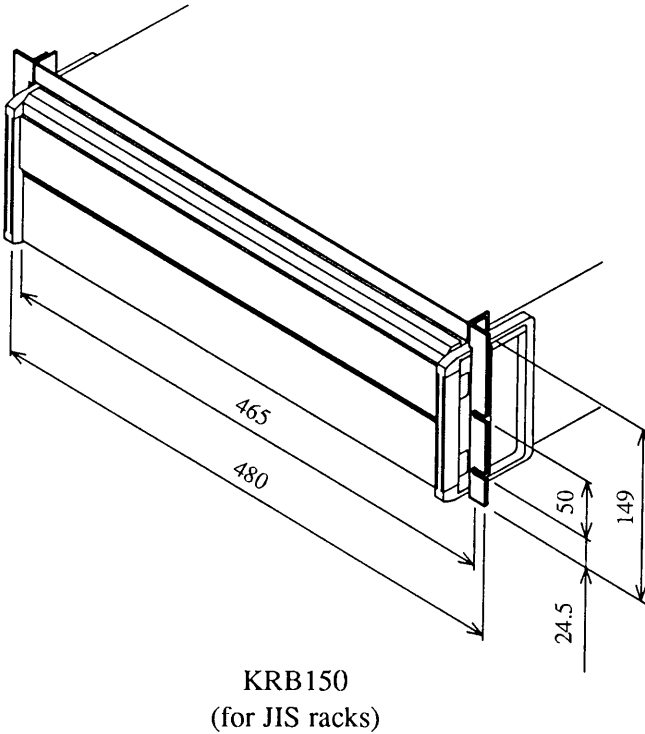
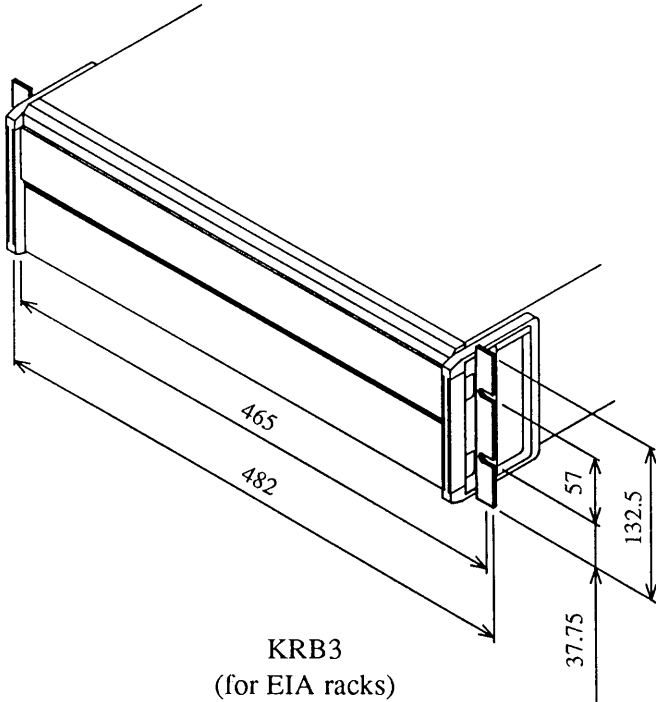

unit : mm

APPENDICES

The appendices on the following pages provide an error message table, a troubleshooting chart, a table of factory-defaults, a menu configuration chart, sequence coding sheets, and a table of ID codes and offset calibration values.

Contents	Page
Appendix 1. Table of Error Messages.....	A-2
Appendix 2. Troubleshooting Chart	A-5
Appendix 3. Table of Factory-Defaults.....	A-7
Appendix 4. Menu Charts	A-8
Appendix 5. Sequence Coding Sheets.....	A-13
Appendix 6. Table of ID Codes and Offset Calibration Values	A-16

Appendix 1. Table of Error Messages

Error Message	Causes and Remedies
CC CAL Data Error.	Error in CC calibration data. Repeat calibration. If the same error persists, order your Kikusui agent for repair.
CONF Data Error.	Error in configuration data. Check the settings.
CONF Data is broken.	Configuration data stored on the internal non-volatile memory is broken. Repeat configuration settings.
CV CAL Data Error.	Error in CV calibration data. Repeat calibration. If the same error persists, order your Kikusui agent for repair.
Can't Cal.Mode CV. Can't Cal.Mode CC. Can't Cal.OVP. Can't Cal.OCP.	Calibration is unsuccessful. Check the wiring and load impedance.
Can't Change L/R.	When the output is ON, you cannot change the modes between Remote and Local.
Can't Change TrTf.	When the output is ON, you cannot change Tr Tf.
Can't Delete.	You cannot delete sequence file "#0".
Can't Edit.	The steps required for editing a new program have not been secured.
Can't Run.	You cannot run a sequence which has not been edited yet.
Data Clip.	The sequence data is greater than the rated output value and the amount of excess is clipped.
EEP Data is broken.	Data stored on EEP ROM has been broken. (The EEP ROM stores default values.) It must be set again.

Error Message	Causes and Remedies
EEP ROM W Error. EEP ROM R Error.	Access to EEP ROM is unsuccessful. Order your Kikusui agent for repair.
ERROR OCP	The overcurrent protector has tripped when at power-on. This will occur if the OCP potentiometer on the front sub-panel is set at a fully counter-clockwise position.
ERROR OHP	The overheat protector has tripped when at power-on. Cool off the power supply and then re-start it.
ERROR OVP	The overvoltage protector has tripped when at power-on. Check for that the OVP potentiometer on the front sub-panel is not set at a fully counter-clockwise position and that no external voltage higher than the OVP trip voltage is applied to the output terminal.
Framing Error.	A framing error has occurred. Check the settings.
I/F Can't Execute	The I/F cannot execute the command given. (For example , a "RUN" command is given when in the "EXECUTE 0" state.) Correctly set the operating mode.
I/F Invalid Data.	An argument of the interface program is invalid. Check the argument of the program.
I/F Syntax Error.	There is a syntax error in a message from the interface.
I/F Warning Data.	An output clip, OVP or OCP warning occurred when execution of sequence was attempted from the interface.
ICAL Data is broken.	The CC calibration data stored on the internal nonvolatile memory has been broken. Repeat calibration.
Invalid TrTf.	You cannot specify TrTf when in the Normal mode.

Error Message	Causes and Remedies
Parity Error.	A parity error has occurred. Check the settings.
Prediction OCP.	A sequence data value is greater than the OCP limit value.
Prediction OVP.	A sequence data value is greater than the OVP limit value.
RX Buff Overflow.	An overflow of the receive buffer occurred.
SEQ Data Error.	An error in sequence data occurred. Check the data of sequence file "#0."
SEQ Data is broken.	Sequence data stored on the internal non-volatile memory is broken. The memory stores the default values. Repeat the settings.
SET Data Error.	An error in setup data occurred. Check the data of setup memory "#0."
SET Data is broken.	Setup data stored on the internal non-volatile memory is broken. The memory stores the default values. Repeat the settings.
System Error.	The internal memory has failed. Order your Kikusui agent for repair.
TX Buff Overflow.	An overflow of the transmit buffer occurred.
VCAL Data is broken.	The CV calibration data stored on the internal nonvolatile memory has been broken. Repeat calibration.

Appendix 2. Troubleshooting Chart

This appendix is to provide you with very basic types of troubleshooting information. The troubleshooting chart given here consists of three types of items, namely, [Symptoms], [Check Items], and [Causes].

When you have verified that the power supply is malfunctioning, immediately stop using the power supply, disconnect the AC input power cable of the power supply from the AC line source (receptacle or power distribution panel), and order your Kikusui agent for repair.

Caution

- Provide a means to prevent the use of the failed power supply (for instance, put an "OUT OF ORDER" tag on the power supply).

WARNINGS

- Never open the casing of the power supply.

[Symptoms]

Even when the POWER switch is turned on, it does not operate and nothing appears on the display.

- [Check Item 1] Is the AC input power fed to the AC input terminal of the power supply?
[Causes] Incorrect connection or open-circuiting of the AC input power cable

- [Check Item 2] Cases to which Check Item 1 does not apply.
[Causes] Circuit failure

[Symptoms]

The AC input power switch cannot be turned ON.

- [Check Item 1] Is not pin ⑦ of the analog remote control terminal (J2) connected to common pin ③?
[Causes] The external contact signal for Power-OFF control is in the ON state.

- [Check Item 2] Is the circuit between pins ① and ② (alarm signal contact) of the analog remote control terminal (J2) closed (for about 60ms)?
[Causes] The OVP has tripped. Check that no external overvoltage is applied to the output terminal.

- [Check Item 3] Cases to which Check Items 1 and 2 do not apply.
[Causes] Circuit failure

[Symptoms]

The power supply does not deliver its output even when its OUTPUT key is pressed.

[Check Item 1] Check that the AC line voltage fed to the input terminal meets the specifications.
[Causes] Has been reset by trip of the input protector.

☞ Check that the specified AC line requirements are met.

[Check Item 2] Cases to which Check Item 1 does not apply.
[Causes] Circuit failure

[Symptoms]

The OVP trips as you press the OUTPUT key to turn ON the output.

[Check Item 1] Is not the voltage setting higher than the software or hardware OVP setting?
 (Check the values with the **[PROTECT]** key.)

[Causes] The voltage setting is higher than the OVP setting.

☞ Lower the voltage setting.

[Check Item 2] Cases to which Check Item 1 does not apply.
[Causes] Circuit failure

[Symptoms]

The output is unstable.

[Check Item 1] Is the remote sensing (if employed) correct?
[Causes] Wrong connections or open-circuiting of the remote sensing wiring

[Check Item 2] Is the analog remote control (if employed) correct?
[Causes] Unstable external control voltage or resistance signal, or incorrect wiring

[Check Item 3] Check that the AC line voltage fed to the input terminal meets the specifications.
[Causes] If the line voltage is low, ripple on the output will increase.

[Check Item 4] Cases to which Check Items 1 through 3 do not apply.
[Causes] Circuit failure

Appendix 3. Table of Factory-Defaults

Operating Mode Select

FAST/NORMAL	FAST (fast speed mode)
-------------	------------------------

Default Setup

OUTPUT	OFF	
V SET	0V	
V FINE	0	
V RESOLN (resolution)	0.1V	
I SET	Rated current	
I FINE	0	
I RESOLN (resolution)	0.1A	
Software OVP	110% of rated output voltage	
OVP Protection Action	Output OFF	
Software OCP	110% of rated output current	
OCP DELAY	2s	
OCP Protection Action	Output OFF	
Tr Tf	50 μ s	
MEM A	V SET	0V
MEM B	V FINE	0
MEM C	I SET	Rated current
MEM D	I FINE	0

Hardware Protection

Hardware OVP	Maximum
Hardware OCP	Maximum

Appendix 4. Menu Charts

This appendix provides protection menu, setup menu, configuration menu, and sequence menu charts.

Protection Menu

[PROTECT]

Initial menu of protectors

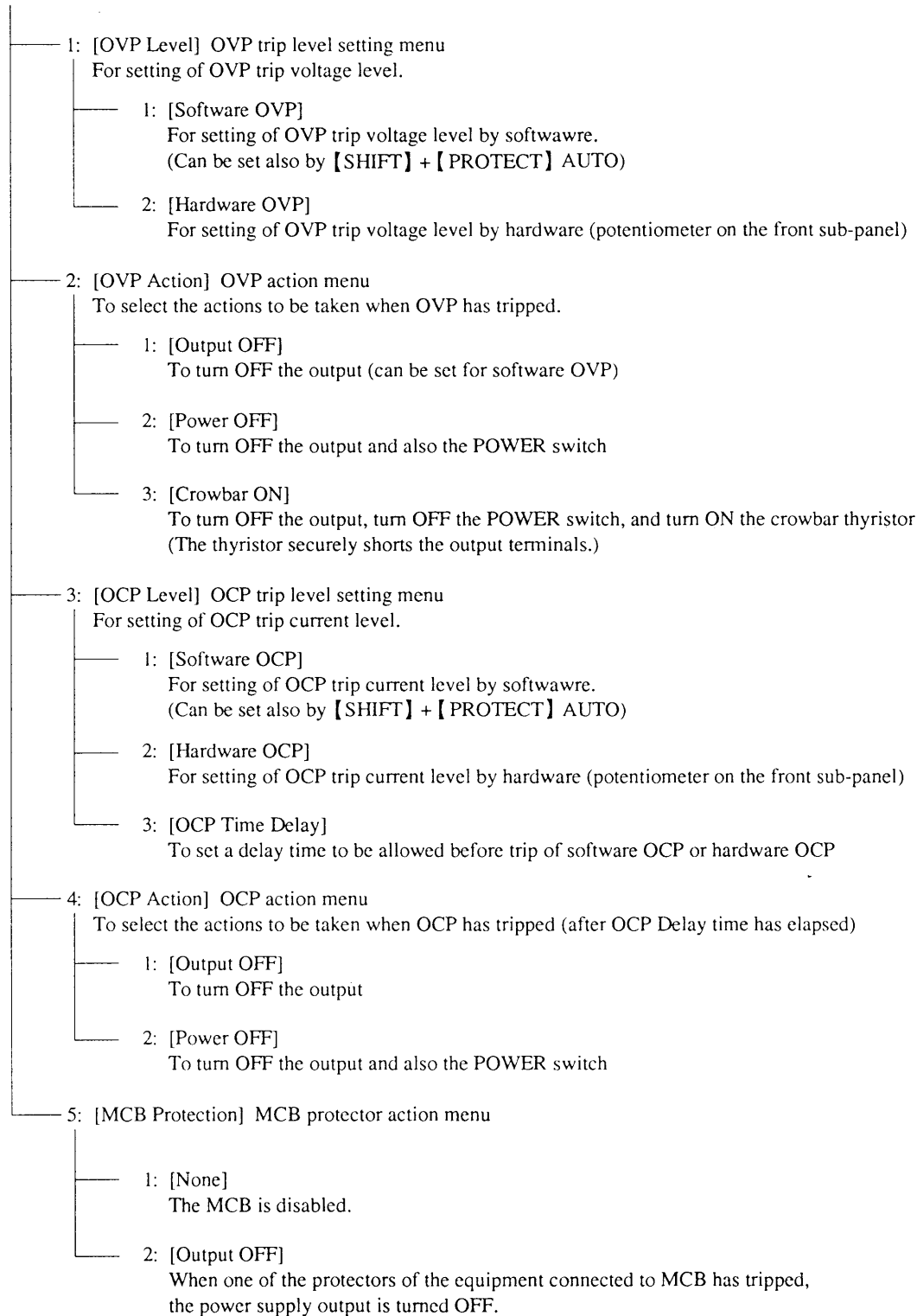

Setup Menu

SETUP
([SHIFT] + [7])

Setup Menu

- 1: [Recall] : To recall the setup data from the specified setup memory.
- 2: [Store] : To save the setup data in the specified setup memory.
- 3: [Store to #0] : To save the setup data in setup memory #0.
- 4: [Initialize] : To initialize the settings.

Items of setup

V SET (voltage setting)
I SET (current setting)
V FINE
I FINE
V RESOLN
I RESOLN
TrTf
Software OVP level
OVP protection action
Software OCP level
OCP protection action
OCP delay time
MCB action
Memory A
Memory B
Memory C
Memory D

Sequence Menu

【SEQ】

Initial sequence menu

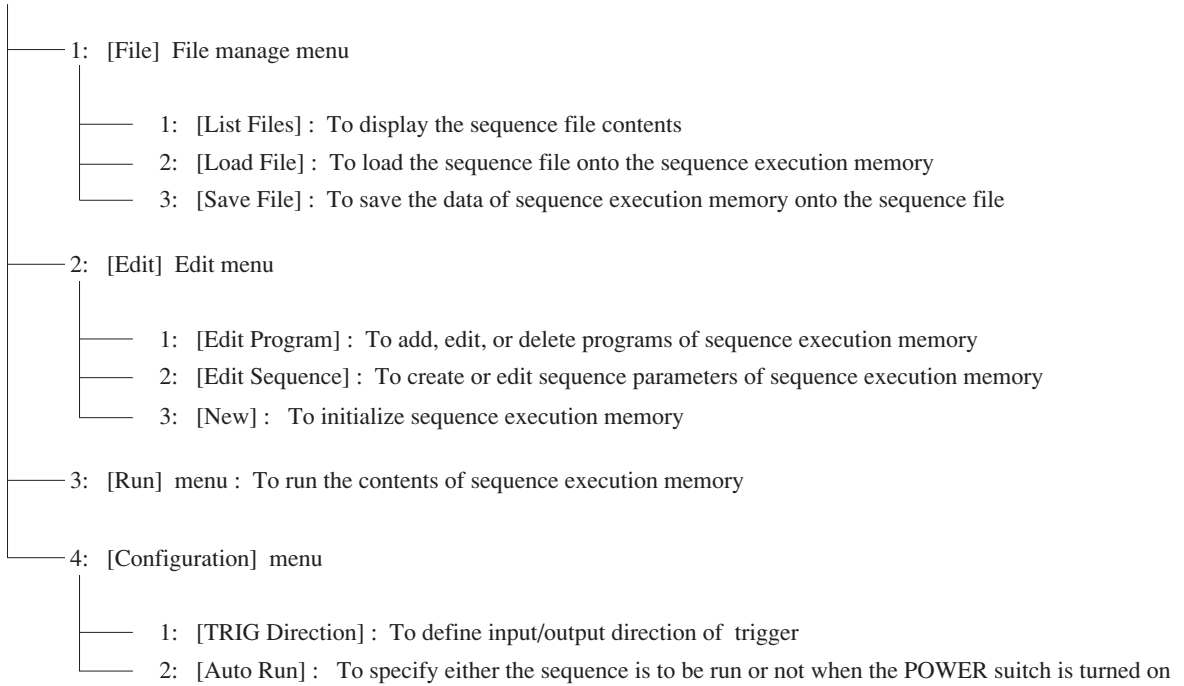

Configuration Menu

CONFIG
(**[SHIFT]** + **[0]**)

Configuration Menu

- 1: [Local/Remote]: Menu to select the local control or the remote control with an external analog signal.
 - 1: [CV, CC Local]: Both voltage and current are locally controlled.
 - 2: [CV Remote]: Voltage alone is remote-controlled with an external analog signal via EXT SIG IN terminal or others
 - 3: [CC Remote]: Current alone is remote-controlled with an external analog signal via EXT SIG IN terminal or others
 - 4: [CV, CC Remote]: Both voltage and current are remote-controlled. (The control signal for voltage is applied via EXT SIG IN terminal or others; that for current is applied via the analog remote control terminal on the rear panel.)
- 2: [Start Up]: Start up menu
 - 1: [Output]: To turn ON or OFF the **[OUTPUT]** key when the power supply is started up
 - 1: [OFF]: The **[OUTPUT]** key is OFF.
 - 2: [ON]: The **[OUTPUT]** key is ON.
 - 2: [Key Lock]: To lock or unlock the keys when the power supply is started up
 - 1: [OFF]: Unlock the keys.
 - 2: [ON]: Lock the keys.
- 3: [ON/OFF Timing]: To select ON/OFF timing
 - 1: [Normal Mode]: Regular mode of operation
 - 2: [CV Mode]: OUTPUT turn ON and OFF with CV operation
 - 3: [CC Mode]: OUTPUT turn ON and OFF with CC operation
- 4: NULL
- 5: [Auto Fine]: Auto Fine menu
 - 1: [CV Auto Fine]: ON/OFF setting of CV Auto Fine
 - 1: [OFF]
 - 2: [ON]
 - 2: [CC Auto Fine]: ON/OFF setting of CC Auto Fine
 - 1: [OFF]
 - 2: [ON]
- 6: [Auto Protection]: To select an auto-protection level for OVP or OCP
 - 1: [110%]
 - 2: [120%]
 - 3: [130%]

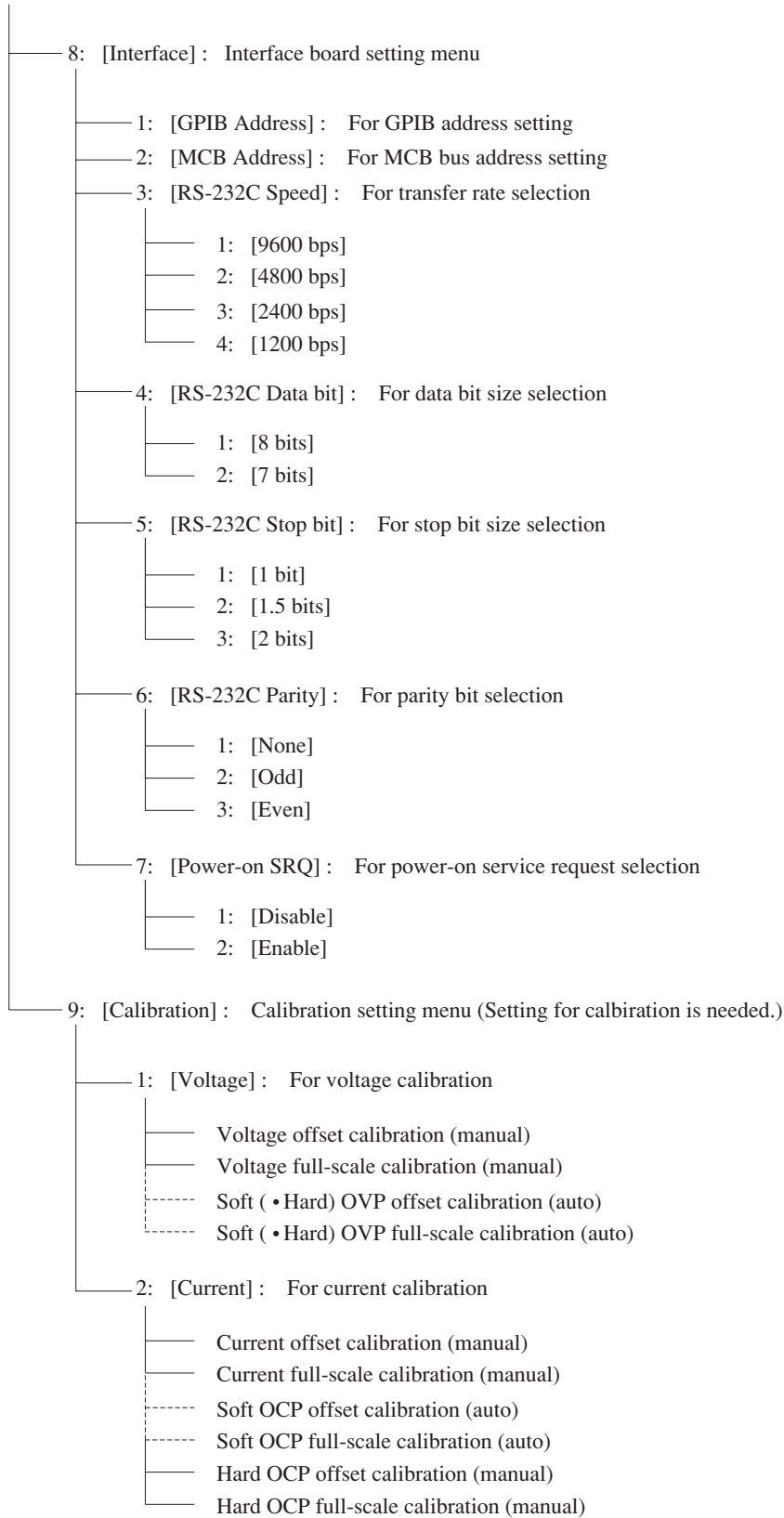

Appendix 5. Sequence Coding Sheets

Coding Sheet (for Normal speed sequence)

Date: _____ Name: _____

Title: _____ Description: _____

Mode : NV NI NVI

Time unit: msec sec minute hour

Sequence

No.	Execute Program	Loop	Chain Sequence	End Program	Comments
S01	P__	L_____	C_	E__	
S02	P	L	C	E	
S03	P	L	C	E	
S04	P	L	C	E	
S05	P	L	C	E	
S06	P	L	C	E	
S07	P	L	C	E	
S08	P	L	C	E	

Program

NO.	Step No.	S/R	CV [V]	S/R	CC [A]	Trig	Out	Pause	Time []	Comments

Coding Sheet (for Fast speed sequence)

Date: _____ Name: _____

Title: _____ Description: _____

Mode : FV FI

Sequence

No.	Execute Program	Loop	Chain Sequence	End Program	Time [msec]	Comments
S01	P_	L_	C_	E_		
S02	P	L	C	E		
S03	P	L	C	E		
S04	P	L	C	E		
S05	P	L	C	E		
S06	P	L	C	E		
S07	P	L	C	E		
S08	P	L	C	E		

Program

NO.	Step No.	CV [V]	CC [A]	Trig	Comments

Examples of Sheet Entry

Date: *date* Name: *Kikusui*

Title: *SAMPLE SEQ.*

Description:

Mode : NV NI (NVI)

Time unit: (msec) sec minute hour

Sequence

No.	Execute Program	Loop	Chain Sequence	End Program	Comments
S01	P01	L0001	C_2	E_16	Start state
S02	P02	L0002	C 3	E 16	Main sequence
S03	P03	L0001	C *	E16	End state
S04	P	L	C	E	
S05	P	L	C	E	
S06	P	L	C	E	
S07	P	L	C	E	
S08	P	L	C	E	

Program

NO.	Step No.	S/R	CV [V]	S/R	CC [A]	Trig	Out	Pause	Time []	Comments
01	001	S	0.00	S	5.00	•	0	•	050	Start Test 1
	002	R	10.00	S	5.00	T	0	•	10	
	003	S	10.00	S	5.00	•	0	•	20	
	004	R	16.00	S	5.00	•	0	•	30	
03	001	S	5.00	S	5.00	•	0	•	30	Test 2
	002	S	15.00	S	5.00	•	0	•	20	
	003	R	0.00	S	5.00	•	0	•	50	
16	001	S	0.00	S	5.00	•	•	•	001	Output off

Appendix 6. Table of ID Codes and Offset Calibration Values

Model	Calibration ID code	Voltage offset calibration value	Current offset calibration value
PAX35-10	3510	0 ~ -0.7mV	0 ~ -0.2mA
PAX35-20	3520	0 ~ -0.7mV	0 ~ -0.4mA
PAX35-30	3530	0 ~ -0.7mV	0 ~ -0.6mA

Index

Alphabetic order

,	4-9
2-terminal variable resistor	3-67, 3-69
3-terminal variable resistor	3-68, 3-70
?	4-9

(A)

AC input power cable	VI, 2-5, 6-3, 7-12
AC input ratings	5-8
AC line requirements	III
Accessories	VI, 7-12
Acknowledge message	4-7
Address	4-30
Air intake	5-5
Air outlet	5-8
Alarm handling actions	3-16
Alarm reset	3-29
Alarm state	1-4
Ambient conditions	7-4
Analog common line	3-67, 3-69
Analog remote control	1-4, 3-65
Analog remote control of output voltage ..	3-67
Analog remote control terminal	5-7
Analog remote control terminal (J2)	3-65
Application programs	4-31
Arrow keys	5-5
AUTO	5-4
AUTO function	1-4, 3-17
Auto protect level in percentage	3-63
Auto protection menu	3-54
Auto run	3-51
AUX OUT terminals	5-5

(B)

Bit assignment of registers	4-25
Board slot	5-6
BS	3-6, 5-2

(C)

Cable clamp	2-6
Calibration	1-4, 6-4

Calibration ID codes and offset	
calibration values	A-16
Calibration instruments	6-4
Calibration procedure	6-5
Calibration setting menu	3-55
Call out and SRQ operation example	4-33
Caution and Warning signs	IV
CC	5-2
CC characteristics	7-3
CC mode	3-60, 3-12
CC remote	3-57
Chain sequence number	3-35
Chassis ground	IV
Click resolution	3-30
CLR	3-6, 5-3
Coding sheet (for Fast speed sequence) ...	A-14
Coding sheet (for Normal	
speed sequence)	A-13
Commands	4-6
Commands and control codes for	
RS-232C only	4-22
Commands and special codes for	
GPIB only	4-24
Commands for MCB only	4-21
Common mode noise	2-7
Compound message	4-6
Conceptual diagram of sequence	
operation	3-39
CONFIG	5-3, A-11
Configuration	3-54
Configuration menu	3-39
Configuration menu	3-54, A-11
Connecting the AC input power cable	2-5
Contact remover	3-66
Contrast control	5-2
Control with external analog signal	3-56
Cooling fan	5-8
CR	4-3, 4-4
Crimping connection tools	3-66
Crimping tool	3-66
Crowbar	5-2
Crowbar thyristor	1-4, 7-8
Current calibration	6-4
Current calibration procedure	6-7
Current monitor	3-71
Current setting keys	5-4
CV	5-2
CV characteristics	7-3

CV mode	3-60, 3-12
CV remote	3-57
CV, CC remote	3-57
CV/CC ON/OFF timing setting	3-60

(D)

Data	4-9
DC voltmeter	6-4
Default setup	A-7
Description of commands	4-9
Digital common line	3-70, 3-71
Dimensions and weights	7-11
Direct setting with numeric entry keys	3-6
Display during sequence operation	3-53
Do not open the casing	II
Dust filter	6-2

(E)

Earth ground	IV
Edit	5-5
Editing menu	3-40
Electrical specifications	7-2
End program	3-38
End program number	3-35
Enter	5-3
Environments	2-2
EOI	4-3
Error codes	4-29
Error messages	A-2
Error register	4-29
ESC	5-3
Example of program for MCB path address designation and simultaneous operation	4-40
Example of program for sequence operation	4-41
Example of program for setting of Fine adjust value	4-36
Example of sequence operation (Normal speed mode)	3-38
Examples of alarm displays	3-19
Examples of program utilizing the memory functions	4-37
Examples of remote programming	4-30
Examples of sequence operation	3-33
Exclusive Remote Controller	7-13
Execution program number	3-35

EXT SIG IN	5-4
------------------	-----

(F)

Factory defaults	3-28
Fast mode	1-3, 2-10
Fast mode indicator	5-3
Fast speed mode	3-33, 3-34
Fast speed sequence	1-3
Fault register	4-26, 4-28
Fault unmask register	4-26, 4-28
FI mode	3-33
File manage menu	3-39
File save, load file	3-48
Fine setting	3-13
Fine voltage setting	3-13
Flow control	4-8
Front panel	3-2, 5-2, 6-2
Front sub-panel	5-4
Function keys	5-3
Functions indicated with black letters	3-6
Functions indicated with blue letters	3-6
FV mode	3-33

(G)

GND	5-7
GPIB interface	4-3
GPIB interface board	4-30
Ground	II, 2-5

(H)

Handle	III
Handle (left)	5-2
Handle (right)	5-4
Hardware OCP	3-14
Hardware OVP	3-14
Hardware protection	3-14, A-7
Hazardous area	II
Header	4-9
High impedance	2-13
Holdoff	4-7
Hood cover	VI, 7-12
How to use the handles	2-4
Humidity range for guaranteed performance	2-2

(I)

I FINE	5-4
I SET	5-4
IB ST	5-3
IB11	7-13
Increase/decrease with arrow keys	3-7
Increase/decrease with JOG dial	3-7
Increase/decrease with SHUTTLE dial ...	3-7
Initial menu of protectors	3-15
Initial setting of interface	4-3
Initialize	3-28
Initialize sequence execution memory	3-39
Initializing the interface board	4-30
Input current vs. output current characteristics	7-5
Input terminal cover	2-5
Input terminals	II, 2-5, 5-8
Inrush current	7-2
Installation	2-2
Instrument weight	5-8
Interface board	1-3, 7-13
Interface board setting menu	3-55
Interface status display	3-32

(J)

J1	5-4
JOG/SHUTTLE	5-4

(K)

Keylock	3-58, 5-3
Keylock function	3-29
KRB3	7-14
KRB150	7-14

(L)

L	5-8
LCD	1-3
Leak current	2-7
LF	4-3, 4-4
Limit	5-2
Load cable	3-20
Load connection	2-14
Load connections	2-12
Local	5-3
Lock switches	2-4

Louvers	6-2
---------------	-----

(M)

Maintenance and inspection	6-2
Mark for inhibition of disassembly or removal	IV
Mark to refer to operation manual	IV
MC11S	7-13
MCB address setting	4-5
MCB interface	4-5
MCB protector action menu	3-15
MCB slave interface board	4-30
MEM Store	5-3
Memory	5-5
Memory functions	3-21
Memory key	5-5
Memory operation, and setup functions ...	4-13
Menu configuration and functions of protectors	3-15
Menu selection	3-8
Menu to select control with external analog signal	3-54
Mode register	4-27, 4-28
Mode select	A-7
Mode select terminals	5-7
Monitor readback	4-31

(N)

N	5-8
Names of panel items	3-2
NI mode	3-33
Noise	2-10
Noise filter	2-7
Noise filter ground	5-7
Normal mode (ON/OFF timing)	3-60
Normal mode (operating mode)	1-3, 2-10
Normal speed mode	3-33, 3-34
Normal speed sequence	1-3
NR1	4-9
NR2	4-9
NR3	4-9
NR4	4-9
Number of loops	3-35
Numeric entry keys	5-3
Nuts	VI, 7-12
NV mode	3-33
NVI mode	3-33

(O)

OCP	5-4
OCP action menu	3-15
OCP trip level setting menu	3-15
ON disable	3-58
ON enable	3-58
ON/OFF control of output	3-70
ON/OFF timing menu	3-54
Operating mode	1-3
Operating mode select terminal	2-11, 5-7
Operating mode selection	2-10
Operation manual	VI, 7-12
Optional items	7-13
Output	5-2
Output change	3-36
Output current control with external resistance signal	3-69, 3-70
Output current control with external voltage signal	3-67
Output key	5-2
Output ON/OFF	3-10, 3-9
Output setting	7-2
Output SW	3-58
Output terminal connection bolts	VI, 7-12
Output terminal cover	VI, 2-12, 7-12
Output terminals	5-7
Output voltage control with external resistance signal	3-67, 3-68
Output voltage control with external voltage signal	3-67
Overhaul	6-3
OVP	5-4
OVP action menu	3-15
OVP trip level setting menu	3-15
OVP/OCP trip level setting with AUTO function	3-17

(P)

Packaging materials	VII
Packing for re-shipment	VII
Panel operating method	3-6
PAUSE	5-5
Pause	3-37
Peak current	2-13
Phase compensation	2-10, 2-13
Phase rotation	2-10, 2-13
POWER switch	3-5, 5-2, 3-71

Power amplifier system	1-2
Power-on test	2-8
Precautions for moving the power supply	2-4
Primary protector	3-14
Procedures for sequence operation	3-40
Product No.	5-8
Program edit	3-42
Program edit display	3-43
Program messages	4-6
Program run	3-52
Programming format	4-6
Programs	3-36
Prompt circulating along menu items	3-8
Protect	5-4, A-8
Protection key	5-4
Protection menu	A-8
Protections	7-4
Protective actions	3-14, 4-31
Protective functions	1-4
Protective provisions	4-14

(Q)

Query message	4-6
---------------------	-----

(R)

Rack mount bracket	7-14
Ramp change	3-36
Re-shipment	VII
Rear panel	3-3, 5-6
Recall	3-25
Recall setting data from memory	3-22
Receiving inspection	VI
Recommendable wire gauges	2-14, 2-5
Relationships among SRQ, status bytes, and registers	4-28
Release from keylock	3-29
Remote controller	1-4
Remote sensing function	3-20
Remote sensing terminals	5-7
Request to send	4-8
Request to stop sending	4-8
Reset	3-6, 5-3
Reset from protection alarm status	3-18
RESOLN (resolution)	5-3
Response message	4-7, 4-9
Response message terminator setting	4-3

- Response terminator 4-31
- Rise/fall time setting 3-31
- Rise/fall waveform 3-12
- ROM Version Number I
- Root display 2-8, 3-5
- RS-232C interface 4-4
- RS-232C interface board 4-30
- RS-232C protocol setting 4-4
- RS-232C terminal to RS11 transmission control 4-8
- RS11 7-13
- RS11 to RS-232C terminal transmission control 4-8
- Run 5-5
- Run menu 3-39
- (S)**
- Seals VI
- Secondary protector 3-14
- Sensing terminals 3-20
- SEQ 5-5, A-10
- Sequence 3-36, 3-42
- Sequence coding sheets A-13
- Sequence commands 4-16, 4-18
- Sequence control 1-3
- Sequence edit 3-45
- Sequence edit display 3-45
- Sequence execution memory 3-39, 3-40
- Sequence file configuration 3-34
- Sequence file for Fast speed mode 3-35
- Sequence file for Normal speed mode 3-35
- Sequence keys 5-5
- Sequence menu A-10
- Sequence operation 3-33
- Sequence operation menu structure and functions 3-39
- Sequence operation modes 3-33
- Sequence operation parameter setting 3-40
- Sequence operation parameters 3-36
- Sequence operation setting 3-39
- Sequence run 3-52
- Setting of auto-protect level 3-62
- Setting of operation parameters for interface board 3-64
- Setting of power-on parameters 3-58
- Setting of registers 4-33
- Setting of trigger and auto run 3-50
- Setting procedure for auto-run 3-51
- Setting the GPIB address 4-3
- Setting the OVP trip voltage 3-16
- Setting the power-on SRQ 4-3
- Setup 5-3
- Setup function 3-23
- Setup function concept diagram 3-23
- Setup function display 3-24
- Setup function menu structure and actions 3-23
- Setup memory 3-23
- Setup memory recall 3-25
- Setup memory save 3-26
- Setup menu 3-23, A-9
- Shielded wires 3-20
- Shift 3-6, 5-3
- Short piece 2-6, 2-11
- Shunt resistor 6-4
- Sign-on display 2-8, 3-5
- Signs and marks IV
- Software OCP 3-14
- Software OVP 3-14
- Software protectors 3-14
- sp 4-9
- Spring washers VI, 7-12
- SRQ 4-28
- Startup menu 3-54
- Status byte 4-28
- Status byte register 4-25, 4-28
- Status indicator 5-2
- Status output signals 3-72
- Status register 4-26, 4-28
- Step add/delete 3-46
- Step change 3-36
- Step delete 3-46
- Step insert 3-46
- Steps 3-36
- Stop 5-5
- Store 3-26
- Store setting data in memory 3-21
- Store to #0 3-27
- "string" 4-9
- Structure and functions of configuration menu 3-54
- Structures of commands 4-10
- SW ON 5-2
- Switchover time 3-12
- System commands 4-23

(T)

Table of blue-letter functions	5-3
Table of command headers	4-45
Table of factory defaults	A-7
Temperature range for guaranteed performance	2-2
Terminal cover	2-11
Terminal for analog remote control	VI, 7-12
Time unit	3-35
To display the remote-controlled value	3-57
To escape from procedure	3-9
To increase/decrease a numeric entry value	3-6
To initialize sequence execution memory	3-40
To initialize the settings	3-28
To load a file	3-48
To recall voltage and current setting data from memory	3-22
To save a setup in setup memory #0	3-27
To select a function	3-6
To select with arrow keys	3-8
To select with JOG dial	3-8
To select with numeric entry keys	3-8
To store voltage and current data in memory	3-13
Tr Tf	5-3
TRIG I/O	5-4
Trigger	7-4
Trigger input	3-37
Trigger input/output setting	3-50
Trigger output	3-37
Troubleshooting	A-5
Twisted pair wires	3-20
Type of data	4-9

(U)

Unmask register	4-25, 4-28
Utility commands	4-20

(V)

V FINE	5-4
V SET	5-4
Voltage calibration	6-4
Voltage calibration procedure	6-5
Voltage click resolution	3-30
Voltage monitor	3-71

Voltage setting	3-10
Voltage setting keys	5-4
Voltage, current, and output control commands	4-10, 4-12
Voltage/current setting	4-31

(W)

Warning and caution signs	IV
Warnings, cautions and notes	V