

USER'S MANUAL

Regulated DC Power Supply PAS Series

350W Type

PAS 10-35	PAS 80-4.5
PAS 20-18	PAS 160-2
PAS 40-9	PAS 320-1
PAS 60-6	PAS 500-0.6

700W Type

PAS 10-70	PAS 80-9
PAS 20-36	PAS 160-4
PAS 40-18	PAS 320-2
PAS 60-12	PAS 500-1.2

1000W Type

PAS 10-105	PAS 80-13.5
PAS 20-54	PAS 160-6
PAS 40-27	PAS 320-3
PAS 60-18	PAS 500-1.8

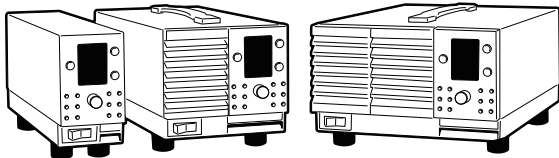

About the Documentation

These manuals are intended for users of the Regulated DC Power Supply and their instructors. It is assumed that the reader has knowledge about electrical aspects of regulated DC power supplies.

Documentation Structure

■User's manual (This manual, PDF)

This manual is intended for first-time users of this product. It provides an overview of the product and notes on usage. It also explains how to configure the product, operate the product, perform maintenance on the product, and so on.

To effectively use the product features, read this manual from beginning to end.

This manual is designed to be read from beginning to end. We recommend that you read it thoroughly before using this product for the first time.

If you forget how to use the product or if a problem occurs, we recommend that you refer to this manual again.

■Setup Guide

This guide is intended for first-time users of the product. It gives an overview of the product, connecting procedures, etc. Please read through and understand this guide before operating the product.

■Quick Reference

The quick reference briefly explains the panel description and the basic operation of the product.

■Connecting & Programming Guide (HTML, PDF)

This manual contains details about remote control.

This is written for readers with sufficient basic knowledge of how to control instruments using a personal computer.

■Safety information

This document contains general safety precautions for this product. Keep them in mind and make sure to observe them.

If you find any misplaced or missing pages in the manuals, they will be replaced. If the manual gets lost or soiled, a new copy can be provided for a fee. To replace or purchase a manual, please contact your Kikusui agent or distributor. At that time, inform your agent or distributor of the "Part No." written on the front cover of this manual.

Every effort has been made to ensure the accuracy of this manual. However, if you have any questions or find any errors or omissions, please contact your Kikusui agent or distributor.

After you have finished reading this manual, store it so that you can use it for reference at any time.

Firmware versions that this manual covers

This manual covers firmware versions 1.0X. When contacting us about the product, please provide us with:

- The model (marked in the top section of the front panel)

- The firmware version (see page P-1)

- The serial number (marked on the rear panel)

Trademarks

Microsoft, Windows, and Visual Basic are registered trademarks of Microsoft Corporation in the United States and/or other countries.

All company names and product names used in this manual are trademarks or registered trademarks of their respective companies.

Copyrights

The contents of this manual may not be reproduced, in whole or in part, without the prior consent of the copyright holder.

The specifications of this product and the contents of this manual are subject to change without prior notice.

PDF and HTML are included on attached CD-ROM.

Adobe Reader is required to view the PDF files. Microsoft Internet Explorer or Google Chrome is required to view the HTML files.

© 2011 Kikusui Electronics Corporation

Safety Symbols

For the safe use and safe maintenance of this product, the following symbols are used throughout this manual and on the product. Understand the meanings of the symbols and observe the instructions they indicate (the choice of symbols used depends on the products).

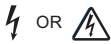

Indicates that a high voltage (over 1,000 V) is used here. Touching the part causes a possibly fatal electric shock. If physical contact is required by your work, start work only after you make sure that no voltage is output here.

DANGER

Indicates an imminently hazardous situation which, if ignored, will result in death or serious injury.



Indicates a potentially hazardous situation which, if ignored, could result in death or serious injury.



Indicates a potentially hazardous situation which, if ignored, may result in damage to the product and other property.



Shows that the act indicated is prohibited.



Is placed before the sign “DANGER,” “WARNING,” or “CAUTION” to emphasize these. When this symbol is marked on the product, see the relevant sections in this manual.



Indicates a protective conductor terminal.



Indicates a chassis(frame) terminal.

Safety Precautions

The following safety precautions must be observed to avoid fire hazard, electrical shock, accidents, and other failures. Keep them in mind and make sure that all of them are observed properly. Using the product in a manner that is not specified in this manual may impair the protection functions provided by the product.



Users

- This product must be used only by qualified personnel who understand the contents of this manual.
- If it is handled by disqualified personnel, personal injury may result. Be sure to handle it under supervision of qualified personnel (those who have electrical knowledge.)
- This product is not designed or produced for home-use or use by general consumers.



Purposes of use

- Do not use the product for purposes other than those described in the manual.

**Line
Voltage**

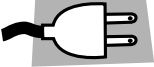

Input power

- Use the product with the specified input power voltage.
- For applying power, use the AC power cord provided. Note that the provided power cord is not use with some products that can switch among different input power voltages or use 100 V and 200 V without switching between them. In such a case, use an appropriate power cord. For details, see the relevant page of this manual.



Cover

- There are parts inside the product which may cause physical hazards. Do not remove the external cover.

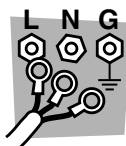

Installation

- When installing products be sure to observe "1.2 Precautions for installation" described in this manual.
- To avoid electrical shock, connect the protective ground terminal to electrical ground (safety ground).
- When applying power to the products from a switchboard, be sure work is performed by a qualified and licensed electrician or is conducted under the direction of such a person.
- When installing products with casters, be sure to lock the casters.



Relocation

- Turn off the power switch and then disconnect all cables when relocating the product.
- Use two or more persons when relocating the product which weights more than 18 kg. The weight of the products can be found on the rear panel of the product and/or in this manual.
- Use extra precautions such as using more people when relocating into or out of present locations including inclines or steps. Also handle carefully when relocating tall products as they can fall over easily.
- Be sure the manual be included when the product is relocated.



Operation

- Check that the AC input voltage setting and the fuse rating are satisfied and that there is no abnormality on the surface of the AC power cord. Be sure to unplug the AC power cord or stop applying power before checking.
- If any abnormality or failure is detected in the products, stop using it immediately. Unplug the AC power cord or disconnect the AC power cord from the switchboard. Be careful not to allow the product to be used before it is completely repaired.
- For output wiring or load cables, use connection cables with larger current capacity.
- Do not disassemble or modify the product. If it must be modified, contact Kikusui agent/distributor.



Maintenance and checking

- To avoid electrical shock, be absolutely sure to unplug the AC power cord or stop applying power before performing maintenance or checking.
- Do not remove the cover when performing maintenance or checking.
- To maintain performance and safe operation of the product, it is recommended that periodic maintenance, checking, cleaning, and calibration be performed.



Service

- Internal service is to be done by Kikusui service engineers. If the product must be adjusted or repaired, contact Kikusui agent/distributor.

Contents

Safety Symbols	I
Safety Precautions	II

Preface

About this manual	P-1
Outline of the PAS series	P-2
Options	P-3

Chapter1 Setup

1.1 Checking at unpacking	1-1
1.2 Precautions for installation	1-3
1.3 Connecting the AC power cord	1-3

Chapter2 Before Using the Unit

2.1 Inrush Current	2-1
2.2 Load	2-1
2.2.1 When Load Current Has Peaks or Is Pulse-Shaped	2-1
2.2.2 When the Load Generates a Reverse Current to the Power Supply	2-2
2.2.3 When the Load Has Accumulated Energy Such as Batteries	2-3
2.3 CV Power Supply and CC Power Supply	2-4
2.4 Alarm	2-7
2.5 Grounding the Output Terminal	2-10

Chapter3 Basic Operation

3.1 Turning on the Power	3-1
3.2 Basic Operation	3-2
3.2.1 Setting the Output	3-3
3.2.2 Setting the OVP (Overvoltage Protection) Trip Point	3-4
3.2.3 Setting the OCP (Overcurrent Protection) Trip Point	3-6
3.2.4 Unit Configuration (CONFIG)	3-7
3.2.5 Using the Unit as a Constant Voltage Power Supply	3-11
3.2.6 Using the Unit as a Constant Current Power Supply	3-12
3.3 Connecting the Load	3-13
3.3.1 Load Cable	3-13
3.3.2 Connecting to the Output Terminals	3-15
3.4 Switching the Power Display	3-18
3.5 LOCK Function	3-19
3.6 Remote Sensing	3-19

Chapter4 Remote Control

4.1	Analog Remote Control	4-1
4.1.1	About the J1 Connector	4-2
4.1.2	Controlling the Output Voltage Using External Voltage	4-5
4.1.3	Controlling the Output Voltage Using External Resistance	4-8
4.1.4	Controlling the output current using external voltage	4-11
4.1.5	Controlling the Output Current Using External Resistance	4-14
4.1.6	Controlling the Output ON/OFF Using External Contact	4-17
4.1.7	Controlling the Output Shutdown Using External Contact	4-19
4.2	Remote Monitoring	4-21
4.2.1	External Monitoring of the Output Voltage and Output Current	4-21
4.2.2	External Monitoring of the Operation Mode	4-22
4.3	Digital Remote Control	4-23
4.3.1	Connecting of the Power Supply Controller and Device messages	4-23

Chapter5 Parallel and Series Operation

5.1	Master-Slave Series Operation	5-2
5.1.1	Functions during Master-Slave Series Operation	5-2
5.1.2	J1 Connector Connection (Series Operation)	5-4
5.1.3	Load Connection for Series Operation	5-5
5.1.4	Master-Slave Series Operation Setup	5-6
5.1.5	Master-Slave Series Operation Procedure	5-7
5.2	Master-Slave Parallel Operation	5-8
5.2.1	Functions during Master-Slave Parallel Operation	5-8
5.2.2	J1 Connector Connection (Parallel Operation)	5-10
5.2.3	Load Connection for Parallel Operation	5-11
5.2.4	Master-Slave Parallel Operation Setup	5-13
5.2.5	Master-slave parallel Operation Procedure	5-14

Chapter6 Names and Functions of Controls

6.1	Front Panel	6-1
6.2	Rear Panel	6-5

Chapter7 Maintenance

7.1	Cleaning	7-1
7.1.1	Cleaning the Panels	7-1
7.1.2	Cleaning the Dust Filter	7-2
7.2	Inspection	7-8
7.3	Calibration	7-8
7.3.1	Test Equipment Required	7-8

7.3.2	Environment	-----	7-9
7.3.3	Calibration Mode	-----	7-10
7.3.4	Calibration Procedure	-----	7-11
7.4	Malfunctions and Causes	-----	7-17

Chapter8 Specifications

Common Specifications	-----	8-2
350W Type Specifications	-----	8-8
700W Type Specifications	-----	8-14
1000W Type Specifications	-----	8-20

Index

This page has been intentionally left blank.

Preface

About this manual

The PAS series is classified into three types depending on the output capacity.

This manual describes the following models.

350W type



PAS10-35, PAS20-18, PAS40-9, PAS60-6, PAS80-4.5
PAS160-2, PAS320-1, PAS500-0.6

700W type



PAS10-70, PAS20-36, PAS40-18, PAS60-12, PAS80-9
PAS160-4, PAS320-2, PAS500-1.2

1000W type

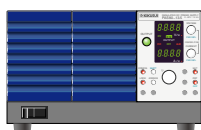

PAS10-105, PAS20-54, PAS40-27, PAS60-18,
PAS80-13.5, PAS160-6, PAS320-3,
PAS500-1.8

For details on the Power Supply Controller, see the operation manual of the respective product. For connection to a Power Supply Controller and device messages, refer to the “Connecting & Programming Guide” [Index.html] in the CD-ROM.

Applicable firmware version of the PAS

This manual applies to PASs with firmware version 1.0x.

When contacting us about the product, please provide us the version number and the manufacturing number that is affixed to the rear panel.

For the procedure for checking the version, see "3.1 Turning on the Power" .

Outline of the PAS series

The PAS series is a regulated DC power supply with a constant voltage/current automatic crossover function utilizing a switching regulator system. It is equipped with communication functions.

■ Features

Power-factor improvement circuit

The power-factor improvement circuit reduces the effects of harmonic currents on the power line.

High efficiency

The high power conversion efficiency reduces the cost of power and the cost of heat radiation design during system configuration.

Communication functions

Equipped with a digital remote control function through TP-BUS (Twist Pair-BUS) communication. (Total length of TP-BUS is 200 m.)

By combining with Kikusui's PIA4800 Series Power Supply Controller, systemization for applications such as an automatic tester is possible.

Master-slave operation

Output voltage or output current can be expanded by connecting multiple power supplies of the same model in series or in parallel and controlling them with a single master device.

Options

Below are options available for the PAS series.

For details on the options, contact your Kikusui agent or distributor.

Rack adapter

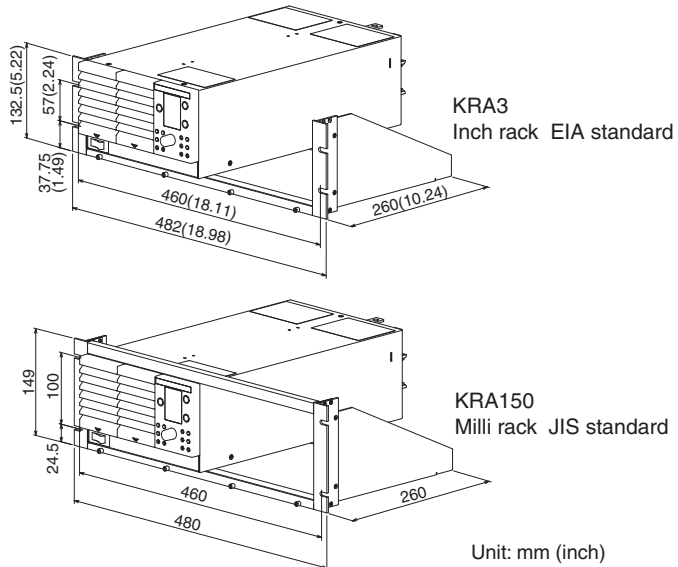

Fig.P-1 Rack adapter

For information on rack adapter mounting, see the KRA3 or KRA150 operation manual.

Remove the handle and rubber feet before you mount the PAS series to a rack.

We recommend that you keep all pieces that you have removed from the PAS series. You will need these pieces if you remove the PAS series from the rack adapter.

If you remove the PAS series from the rack, re-attach the original rubber feet.

NOTE

- To reinstall the handle that has been removed, use screw locking agent (e.g., 1401B by ThreeBond International, Inc.) to prevent screws from loosening.
-

Analog Remote Control Connector Kit (OP01-PAS)

A kit for connecting to the J1 connector on the rear panel.

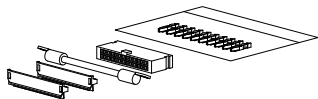

Component	Quantity
Socket	1 pc.
Pins	10 pcs.
Protection cover	1 set
Chassis connection wire	1 pc.

Fig.P-2 Analog remote control connector kit

This chapter describes the necessary procedure from unpacking to preparation before use.

1.1 Checking at unpacking

When you receive the product, check that all accessories are included and that the accessories have not been damaged during transportation. If any of the accessories are damaged or missing, contact your Kikusui agent /distributor.

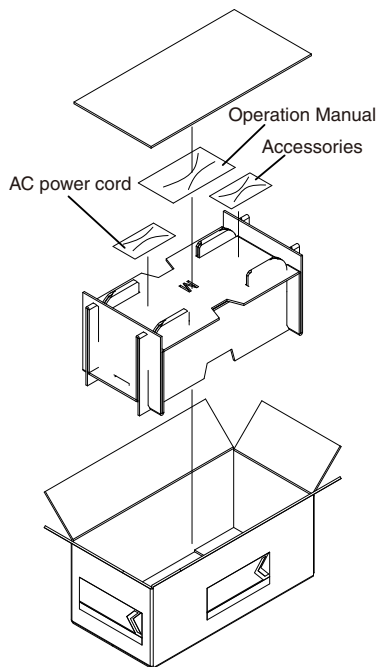
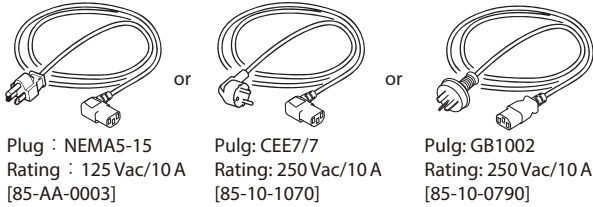

Fig.1-1 Packing/Unpacking (example for 700W type)

NOTE • We recommend that all packing materials be saved, in case the product needs to be transported at a later date.



The power cord that is provided varies depending on the destination for the product at the factory-shipment.

- Power cord for the 350W/700W type (approx. 2.5 m)

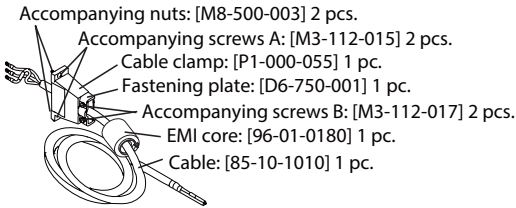

For products with CE Marking (CE mark on the top cover), an EMI core [96-01-0180] is embedded in the AC power cord.

- Power cord for the 1000W type (with cable clamp, no plug and approx. 2.5 m)

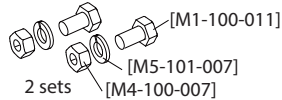

- OUTPUT terminal cover

- M8 output terminal screws

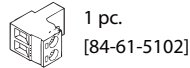

- M4 output terminal screws

- TP-BUS connector

- CD-ROM (1 pc.)

- Safety information (1 pc.)

- Setup Guide (1 pc.)

- Quick Reference
 English 1 pc., Japanese 1 pc.

These parts are installed in body.

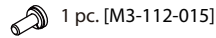
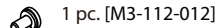
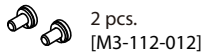

- M3 sensing terminal screws

- M3 screws for chassis connection wire



- J1 protection socket

- J1 lock lever

Fig.1-2 Accessories

1.2 Precautions for installation

When installing this product, be sure to observe the precautions provided in the Safety information manual. Items specific to this product are given below.

■ **When installing this product, be sure to observe the temperature and humidity ranges indicated below.**

Operating temperature range: 0 °C to +50 °C (+32 °F to +122 °F)

Operating humidity range: 20 % to 85 % RH
(no dew condensation is allowed)

■ **When storing this product, be sure to observe the temperature and humidity ranges indicated below.**

Storage temperature range: -25 °C to +70 °C (-13 °F to +158 °F)

Storage humidity range: 90 % RH or less
(no dew condensation is allowed)

1.3 Connecting the AC power cord

The AC power cord provided with the product varies depending on the type.

For the connection procedure, see the respective section for each type.

350W and 700W types

⚠ WARNING Risk of electric shock.

- The PAS series conforms to IEC Safety Class I (equipment that has a protective conductor terminal). Be sure to earth ground the product to prevent electric shock.
- The PAS series is grounded through the power cord ground wire. Connect the protective conductor terminal to earth ground.

NOTE

- Use the supplied power cord to connect to the AC line. If the supplied power cord cannot be used because the rated voltage or the plug shape is incompatible, have a qualified engineer replace it with an appropriate power cord that is 3 m or less in length. If obtaining a power cord is difficult, contact your Kikusui agent or distributor.

- Do not use the AC power cord provided with the product as a AC power cord for other instruments.
 - The power cord with a plug can be used to disconnect the PAS series from the AC power line in an emergency. Connect the plug to an easily accessible power outlet so that the plug can be removed from the outlet at any time.
 - Secure adequate space around the power plug. Do not insert the power plug to an outlet where accessibility to the plug is poor. And, do not place objects near the outlet that would result in poor accessibility to the plug.
-

Connection procedure

- 1. Check that the supply voltage is within the line voltage range of the power supply.**

Input voltage range: 100 VAC to 240 VAC

Frequency range: 50 Hz to 60 Hz

- 2. Turn OFF the POWER switch.**
- 3. Connect the AC power cord to the AC INPUT connector on the rear panel.**

Use the provided power code or power code that is selected by qualified personnel.

- 4. Plug in the AC power cord.**

1000W type

The AC power cord that is included with the 1000W type can be used on either a 100-VAC or 200-VAC system.

⚠ WARNING Risk of electric shock.

- Before you connect the power cord, turn off the switchboard breaker (a switch that cuts off the power supply from the switchboard).
- The PAS series is an IEC Safety Class I equipment (equipment with a protective conductor terminal). Be sure to ground the product to prevent electric shock.
- Connect the ground terminal to earth ground.
- Be sure to have a qualified engineer connect the power cable to the switchboard.
- The switchboard breaker must meet the requirements shown below.

⚠ CAUTION • Inside the power supply, an appropriate protective circuit is connected to the input terminal. Be sure to connect the wires correctly by matching the U, V, W, and ⊕ (GND) between the switchboard and the PAS series.

-
- NOTE**
- Use the supplied power cord to connect to the AC line.
 - In an emergency, turn off the switchboard breaker to disconnect the PAS series from the AC power line.
-

The PAS series is a piece of equipment that conforms to IEC Over-voltage Category II (equipment that consumes energy supplied from a fixed installation).

■ Switchboard breaker requirements

- Rated current: 20 A (100 V system)/ 10 A (200 V system)
For safety, breakers whose rated current exceeds the specified current cannot be used.
- Only use the breaker with the PAS series.
- Keep the breaker readily accessible at all times.
- Indicate that the breaker is dedicated for use with the PAS series and that it is used to disconnect the product from the AC power line.

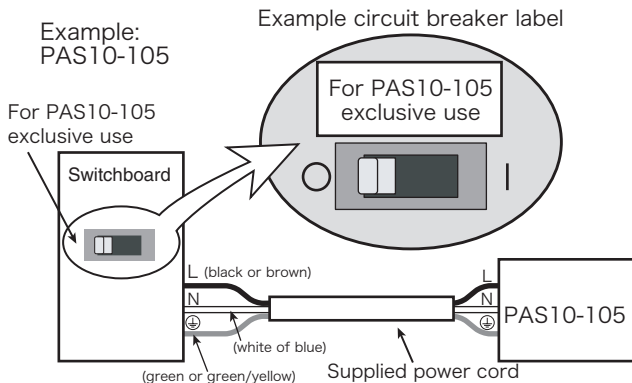

Fig.1-3 Connecting to the switchboard (Example: PAS10-105)

Connection procedure

1. Check that the supply voltage is within the line voltage range of the power supply.
Input voltage range: 100 VAC to 240 VAC
Frequency range: 50 Hz to 60 Hz
2. Turn OFF the POWER switch.
3. Connect the provided AC power cord to the AC INPUT terminal board as shown in Fig.1-4.
4. Attach crimp terminals to the AC power source side of the AC power cord.
5. Turn OFF the switchboard.
6. Connect the AC power cord to match the L, N, and GND of the switchboard.

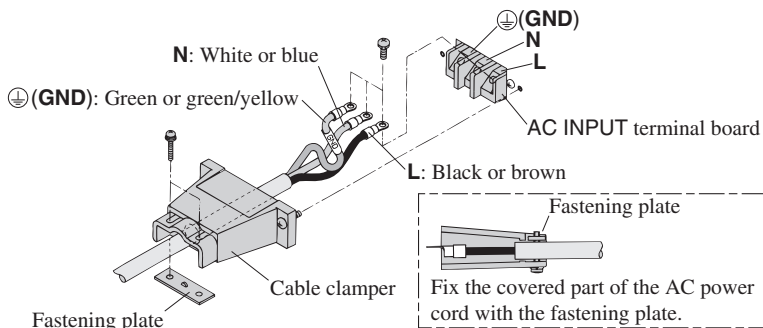



Fig.1-4 Connection of the AC power cord on the unit side

Before using the unit, users are requested to thoroughly understand the following matters.

2.1 Inrush Current

An inrush current flows when the POWER switch is turned on. If you are planning to use several sets of the unit in a system and turn on their POWER switches simultaneously, check that the AC power source or the switchboard is of sufficient capacity.

For details on the inrush current of each model, see Chapter8 "Specifications".

 **CAUTION** • Allow at least 10 seconds between power cycles. Repeated on/off of the POWER switch at short intervals can cause malfunction of the inrush current limiting circuit and shorten the service life of the input fuse and POWER switch.

2.2 Load

Note that the output will become unstable if the following types of loads are connected.

1. When Load Current Has Peaks or Is Pulse-Shaped
2. When the Load Generates a Reverse Current to the Power Supply
3. When the Load Has Accumulated Energy Such as Batteries

2.2.1 When Load Current Has Peaks or Is Pulse-Shaped

The current meter on the unit indicates only mean values. Even when the indicated value is less than the preset current value, the peak values may actually exceed the preset current value. In such case, the unit is instantaneously put into constant-current operation mode, and the output voltage drops accordingly.

For these types of loads, you must increase the preset current value or increase the current capacity.

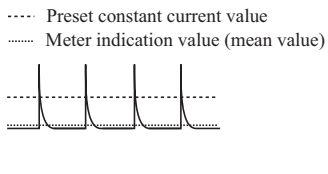

Fig.2-1 Load current with peaks

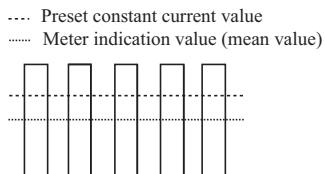

Fig.2-2 Pulse-shaped load current

2.2.2 When the Load Generates a Reverse Current to the Power Supply

The unit cannot absorb a reverse current from a regenerative load such as an inverter, converter, or transformer that supplies current to a power supply. Consequently, the output voltage will increase and the output will fluctuate.

For these types of loads, connect a resistor R_D as shown in Fig.2-3 to bypass the reverse current. However, the current capacity to the load decreases by I_{rp} .

CAUTION • For resistor R_D , select an appropriate resistor rated for the power (allowing sufficient margin). If a resistor with insufficient rated power for the circuit is used, it may burn out.

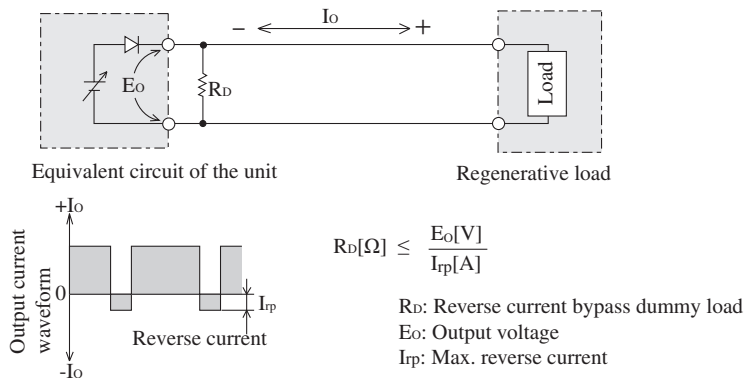

Fig.2-3 Remedy for regenerative load

2.2.3 When the Load Has Accumulated Energy Such as Batteries

Connecting a load with accumulated energy, such as a battery, to the unit may cause current to flow from the load to the internal circuit of the unit. This current may damage the unit or reduce the life of the load.

For this type of loads, connect a reverse-current-prevention diode (DRP) between the unit and the load in series as shown in Fig.2-4.

-
- ⚠ CAUTION**
- To protect the load and the unit, select DRP according to the following criteria.
 1. Reverse voltage withstand capacity: At least twice the rated output voltage of the unit.
 2. Forward current capacity: Three to ten times the rated output current of the unit.
 3. A diode with small loss.
 - Be sure to take into account the heat generated by DRP. DRP may burn out with inadequate heat dissipation.
 - Cannot be used in combination with remote sensing.
-

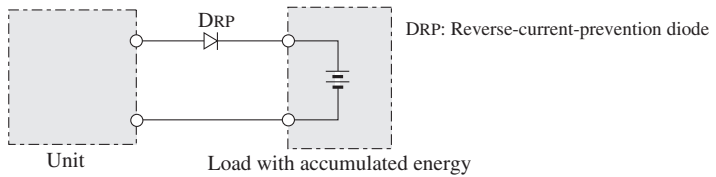

Fig.2-4 Remedy against load with accumulated energy

2.3 CV Power Supply and CC Power Supply

This unit is capable of both constant voltage and constant current operation. This section describes these operations.

An ideal constant voltage power supply has zero output impedance at all frequencies and maintains a constant voltage against all types of load current variations. An ideal constant current power supply has infinite output impedance at all frequencies and maintains constant current by absorbing the load resistance variations by changing the voltage.

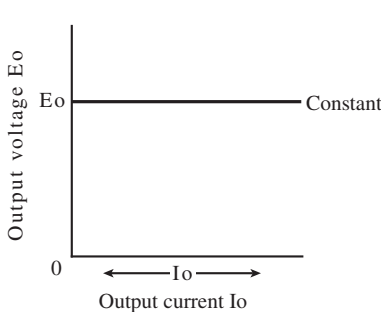

Fig.2-5 Ideal constant voltage power supply

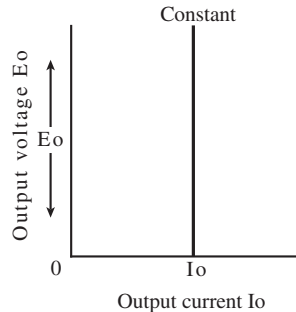

Fig.2-6 Ideal constant current power supply

However, the output impedance of an actual constant voltage or constant current power supply is neither zero nor infinite and has a frequency response. In addition, since the output has limitations in terms of maximum voltage and maximum current, power supplies are unable to maintain a constant voltage or current for all types of load current variations and load resistance variations. The following describes the relationship between the basic operations in constant voltage (CV) and constant current (CC) modes and the limit setting of the unit.

The following description assumes a power supply with a DC output of 100 V and 10 A (maximum rated output voltage of 100 V and maximum rated output current of 10A) as an example.

A resistive load of 10 Ω is connected to the output terminals of the power supply, and the output current limit is set to 5 A. In this condition, the output voltage is raised gradually from 0 V. At this point, the power supply is operating in the constant voltage (CV) mode. The

output current increases as the output voltage increases. When the output voltage reaches 50 V (that is, the output current has reached 5 A), the output voltage no longer increases even if you attempt to raise it. This is because the output current is limited to 5 A specified initially, causing the power supply to switch to the constant current (CC) operation mode. In this way, the power supply automatically switches from the constant voltage to constant current operation to prevent an overcurrent from flowing. (The point at which the operation mode switches is called the "crossover point".) If the current limit is raised in this condition, the power supply returns to the previous constant voltage operation, allowing you to increase the output voltage further. If the current limit is increased from 5 A to 9 A in Fig.2-7, a voltage of up to 90 V can be output.

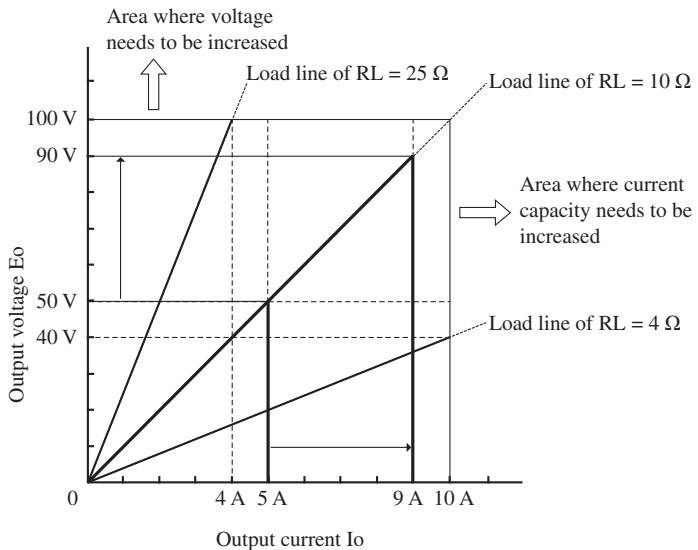

Fig.2-7 Constant voltage operation and constant current operation

Next, let's assume the case in which a load resistance of 4Ω is used. The output current limit is considered to be the rated maximum output current. If you increase the output voltage from 0 V, the output current reaches the output current limit when the output voltage reaches 40 V; the power supply cannot output a voltage above 40 V. This is the limit even though the power supply is generating less than half its output capacity in terms of power. If you wish to increase the

output voltage further, the unit needs to be replaced by a model having larger current capacity. Particularly for loads into which a transient peak current flows, the current must be set such that its peak does not reach (or exceed) the current limit. If the unit enters constant current operation mode even when the current is set to the rated output current, the current capacity needs to be raised.

Next, we consider a case in which a load resistance of $25\ \Omega$ is used. In this case, if the output current limit is set to 4 A or more, the power supply can output voltages from 0 V to the rated maximum output voltage in the constant voltage operation mode. The output voltage limit is set to the rated maximum output voltage under this load condition, and the output current is gradually increased from 0 A. At this point, the power supply is operating in the constant current (CC) mode. The output voltage increases as the output current increases. When the output voltage reaches 100 V, the output current no longer increases even if you attempt to raise it. If you wish to increase the current flow further in this condition, the unit needs to be replaced by a model having higher output voltage. Particularly for loads that generate transient surge voltage, the voltage must be set so that the surge voltage does not reach (or exceed) the voltage limit.

2.4 Alarm

The unit is equipped with the following protection function. When the protection function is activated, "ALM" on the front panel display lights, and the OUTPUT is turned off or the POWER switch is shut down. However, the only action available when OHP is activated is turning off the OUTPUT. (See Fig.2-8.)

In addition, an ALARM signal is output to pin 20 of the J1 connector when the protection function is activated. (See Fig.2-9.)

For details on selecting whether to turn off the OUTPUT or shut down the POWER switch when an alarm is activated, see "3.2.4 Unit Configuration (CONFIG)".

When POWER switch shutdown is selected, the illumination of "ALM" and the ALARM signal output is held for approximately 0.5 s.

Recovery from an alarm

- When POWER switch shut down is selected
After clearing the abnormal condition that caused the alarm, turn on the POWER switch.
- When OUTPUT OFF is selected
Turn off the POWER switch, clear the abnormal condition that caused the alarm, and turn on the POWER switch.

■ Protection Function

- OVP (overvoltage protection)

The overvoltage protection function protects a load from unexpectedly high voltage. The function is activated when the voltage exceeds a preset voltage (OVP trip point).

Selectable range: 10 % to 110 % of the rated output voltage.

If the OVP function is activated when CONFIG is set to OUTPUT OFF, the voltage display shows "OVP."

For details, see "3.2.2 Setting the OVP (Overvoltage Protection) Trip Point".

- OCP (overcurrent protection)

The overcurrent protection function protects a load from unexpectedly high current. The function is activated when the current exceeds a preset current (OCP trip point).

Selectable range: 10 % to 110 % of the rated output current.

If the OCP function is activated when CONFIG is set to OUTPUT OFF, the voltage display shows "OCP."

For details, see "3.2.3 Setting the OCP (Overcurrent Protection) Trip Point".

- OHP (Overheat Protection)

This function is activated when the internal temperature of the unit raises abnormally.

This function protects the unit from the following conditions.

- When the unit is used in an environment exceeding the operation temperature range
- When the unit is used with the inlet or exhaust port blocked
- When the fan motor stops

If the OHP function is activated, the voltage display shows "OHP".

If the condition that caused the OHP to be activated is not corrected, the OHP function is activated again when the POWER switch is turned on.



Fig.2-8 ALARM indication example (OHP)

- SHUT (Shutdown)

The OUTPUT or the POWER switch can be turned OFF by applying a shutdown signal to the J1 connector on the rear panel. If the shutdown signal is applied when CONFIG is set to OUTPUT OFF, the voltage display shows "SHUT."

For details, see "4.1.7 Controlling the Output Shutdown Using External Contact".

■ Alarm Signal

Since the alarm signal output uses an open-collector photocoupler, it is isolated from other terminals.

Maximum voltage: 30 V

Maximum current: 8 mA

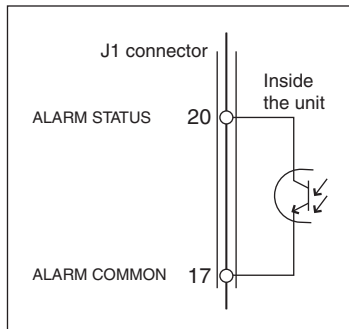

Fig.2-9 ALARM signal

2.5 Grounding the Output Terminal

⚠ WARNING

• For safety reasons, even if the output terminal is grounded, make sure the insulation capacity of the output terminal (including the sensing terminal) is greater than the isolation voltage of the unit.

If you cannot obtain a cable with sufficient rated voltage, secure adequate withstand voltage such as by passing the cable through an insulation tube with a withstand voltage greater than the isolation voltage of the unit.

If adequate insulation measures are not taken against the isolation voltage of the unit, electric shock may occur when grounding is poor.

• If the unit is to be remotely controlled through an external voltage source (Vext), do not ground the Vext output (leave it floating). If the Vext output is grounded in the example shown in Fig.2-11, the output is short-circuited (which can cause accidents).

The output terminal of the unit is isolated from the protective grounding terminal. By connecting the GND wire of the AC power cord to the ground terminal of the switchboard, the chassis of the unit is set to ground potential (see Fig.2-10).

Consequently, the cable and load that are connected to the output terminal (including the sensing terminal) must have an insulation capacity that is greater than the isolation voltage of the unit with respect to the chassis.

In addition, pins 3 through 9 of the J1 connector on the rear panel (for analog remote control and output monitoring) are at approximately the same potential as the - (neg.) output terminal of the unit. Therefore, cables and devices that are connected to these pins must also have an insulation capacity that is greater than the isolation voltage of the unit.

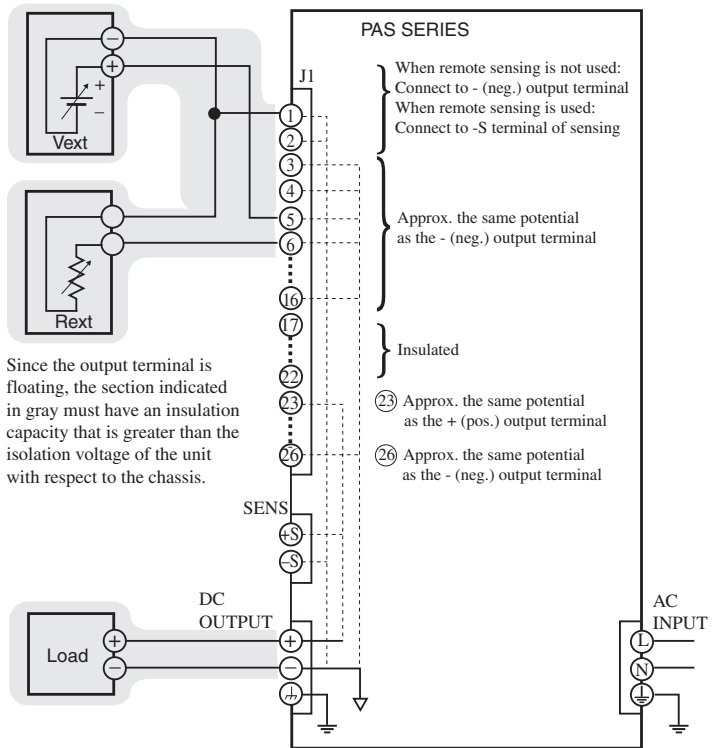

Fig.2-10 When the output terminal is not grounded

Next, let's consider the case when the output terminal is grounded.

Fig.2-11 shows the case when the + (pos.) output terminal is connected to the chassis terminal. In this case, the + (pos.) output terminal is at ground potential. Therefore, the cable and load that are connected to the output terminal (including the sensing terminal) only require an insulation capacity that is greater than the maximum output voltage of the unit with respect to the chassis.

The same holds true when the - (neg.) terminal is connected to the chassis terminal. The cable and load require an insulation capacity that is greater than the maximum output voltage of the unit.

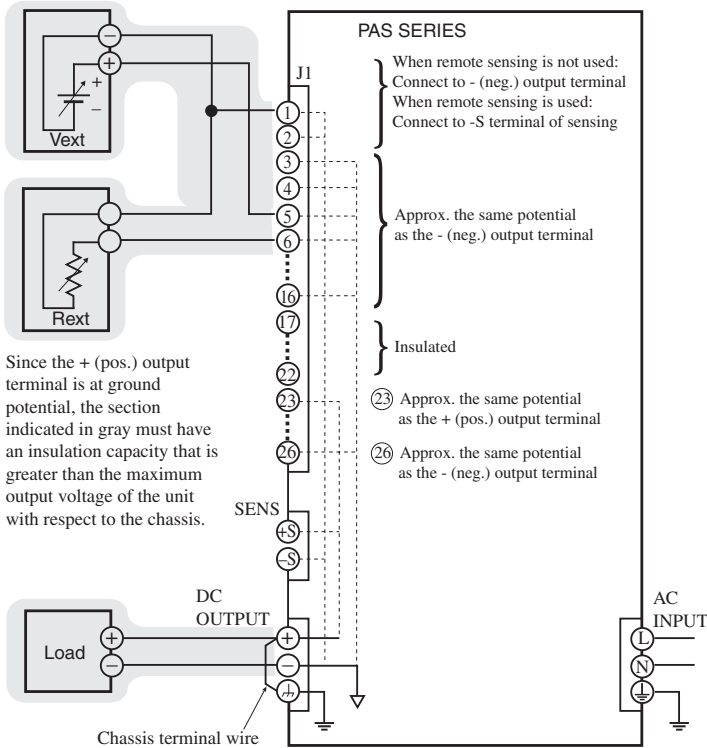

Fig.2-11 When the + (pos.) output terminal is grounded

For safety reasons, connect either output terminal to the chassis terminal unless your application requires the output terminal to be floating.

This chapter describes how to turn on the power and the basic operations that you can carry out from the front panel.

3.1 Turning on the Power

-
- ⚠ CAUTION** • Allow at least 10 seconds between power cycles. Repeated on/off of the POWER switch at short intervals can cause malfunction of the inrush current limiting circuit and shorten the service life of the input fuse and POWER switch.
-

Power up procedure

1. Check that the POWER switch is turned OFF.
2. Check that the AC power cord is correctly connected.
3. Turn on the POWER switch.

The voltage and current displays show the version number of the unit for a few seconds (see Fig.3-1).

After a few seconds, the unit is ready for operation (displays the output value).

Now, the unit is ready for use.



Fig.3-1 Version display example at power up

The display that appears when the POWER switch is turned on for the first time corresponds to factory default settings.

The unit stores the panel settings (excluding OUTPUT ON/OFF condition) immediately before the POWER switch is turned off. The previous panel settings are used the next time the POWER switch is turned on.

For factory default settings, see below.

Factory default settings

Output voltage : 0 V
Output current : Maximum preset current
(105 % of the rated output current)

OVP (overvoltage protection): 110 % of the rated output voltage

OCP (overcurrent protection): 110 % of the rated output current

CONFIG settings

CV control : 0 (Panel control)
CC control : 0 (Panel control)
Remote sensing : 0 (OFF)
PWR ON OUTPUT : 0 (OFF at startup)
Master-slave operation : 0 (MASTER/LOCAL)
EXT OUTPUT : 0 (HIGH=ON)
TERMN : 0 (OFF)
POWER switch trip : 0 (Enable)

3.2 Basic Operation

First, the procedure for setting the output and the protection function trip point will be explained. Next, the procedure for using the unit as a constant voltage or constant current power supply will be described.

For details on the display sections and switches, see Chapter6 "Names and Functions of Controls".

3.2.1 Setting the Output

Here, we will look at an example in which the output is set to 35 V and 7.5 A using the PAS40-9.

Setting the output of the PAS40-9 to 35 V and 7.5 A

1. Check that the LOCK switch is turned off.

You cannot set the output if this switch is illuminated.

2. Check that OUTPUT OFF in the display section is illuminated.

If OUTPUT ON is illuminated, press the OUPUT switch to turn it OFF.

3. Check that the SET switch is illuminated.

If it is not, press the SET switch to turn it on.

If this switch is not illuminated, the actual output value is displayed on the panel.

NOTE

- If you turn the dial when the OUTPUT switch is off, the SET switch is automatically illuminated even if it is not, and the unit enters the setup condition.
- If you turn on the OUTPUT switch, the SET switch automatically turns off even if it is on, and the panel displays the output value.

-
4. Press the VOLTAGE switch to select Coarse or Fine (preset digit).

You can also switch between Coarse and Fine by pressing the dial. (The digit that is displayed brightly is the digit that you are setting. The Coarse and Fine digits vary depending on the model.)

5. Turn the dial to set the value to "35.00."

We are done setting the voltage. Next, we will set the current. Proceed to step 6 .

6. Press the CURRENT switch to select Coarse or Fine (preset digit).

You can also switch between Coarse and Fine by pressing the dial. (The digit that is displayed brightly is the digit that you are setting. The Coarse and Fine digits vary depending on the model.)

7. Turn the dial to set the value to "7.5."

We are done setting the current.

3.2.2 Setting the OVP (Overvoltage Protection) Trip Point

The OVP function protects a load from unexpectedly high voltage. When OVP is activated, "ALM" on the display lights, and the OUTPUT is turned off or the POWER switch is tripped. (Selectable range: 10 % to 110 % of the rated output voltage)

For details on setting whether to turn off the OUTPUT or trip the POWER switch when OVP is activated, see "POWER switch trip when the protection circuit is activated (DEGIT H)" in "3.2.4 Unit Configuration (CONFIG)".

If the POWER switch trip is set to enable when the protection circuit is activated in CONFIG, the illumination of "ALM" and the ALARM signal output is held for approximately 0.5 s.

To release the alarm when the POWER switch is not set to trip when the protection circuit is activated in CONFIG, turn off the POWER switch once.

NOTE

- The OVP trip point is factory-preset to approximately 110 % of the rated output voltage of the unit. When using the unit, set an appropriate OVP trip point for the load.
 - When checking the OVP operation, the unit must be started with the OUTPUT turned off. Therefore, check that PWR ON OUTPUT in the CONFIG settings is set to "0." For details on CONFIG settings, see "3.2.4 Unit Configuration (CONFIG)".
 - The OVP function of the unit operates against the output terminal voltage. If you wish to operate the function against the voltage across the load, set the OVP trip point by considering the voltage drop of the load cable.
-

Setting the OVP trip point

1. Check that no load is connected to the output terminal.
Since we will check the OVP operation by actually outputting a voltage after setting the OVP trip point, remove the load.
2. Turn on the POWER switch.
3. Check that the OUTPUT OFF is illuminated.

4. Press the OVP switch.
The voltage display shows the preset value, and the current display shows "OVP."
5. Press the VOLTAGE switch to select Coarse or Fine (preset digit).
You can also switch between Coarse and Fine by pressing the dial. (The digit that is displayed brightly is the digit that you are setting. The Coarse and Fine digits vary depending on the model.)
6. Turn the dial to set the OVP trip point.
Next, we will check the operation. Proceed to step 7 .
7. Press the OVP switch to escape from the OVP setup mode.
8. Press the SET switch to enter the output setup mode.
SET switch lights.
9. Press the VOLTAGE switch and set the output voltage to a value significantly less than the OVP trip point voltage.
10. Press the OUTPUT switch to illuminate OUTPUT ON.
11. Gradually turn the dial clockwise, and check that the OUTPUT turns off or the POWER switch trips when the output voltage reaches the preset OVP trip point voltage.
When the POWER switch is not set to trip when the protection circuit is activated in CONFIG, ALM lights in the display section and the voltage display shows "OVP."

We are done setting the OVP trip point.

You can set or confirm the OVP trip point even when OUTPUT is turned on. In this case, if the OVP trip point voltage is set lower than the preset output voltage, OVP is activated and the OUTPUT turns off or the POWER switch trips.

The following conditions activate the OVP function.

- When the preset voltage is higher than the OVP trip point voltage.
- When the sensing wire comes loose.
- When the load is abnormal.
- When the unit is abnormal.

If you turn on the POWER switch without correcting the cause, OVP is activated again.

3.2.3 Setting the OCP (Overcurrent Protection) Trip Point

The OCP function protects a load from unexpectedly high current. When OCP is activated, "ALM" on the display lights, and the OUTPUT is turned off or the POWER switch is tripped. (Selectable range: 10 % to 110 % of the rated output current)

For details on setting whether to turn off the OUTPUT or trip the POWER switch when OCP is activated, see "POWER switch trip when the protection circuit is activated (DEGIT H)" in "3.2.4 Unit Configuration (CONFIG)".

If the POWER switch is set to trip when the protection circuit is activated in CONFIG, the illumination of "ALM" and the ALARM signal output is held for approximately 0.5 s.

To release the alarm when the power switch is not set to trip when the protection circuit is activated in CONFIG, turn off the POWER switch once.

NOTE • The OCP trip point is factory-preset to approximately 110 % of the rated output current of the unit. When using the unit, set an appropriate OCP trip point for the load.

Setting the OCP trip point

1. Turn on the POWER switch.
2. Check that the OUTPUT OFF is illuminated.
3. Press the OVP switch while pressing the SHIFT switch.
The voltage display shows "OCP," and the current display shows the preset value.
4. Press the CURRENT switch to select Coarse or Fine (preset digit).
You can also switch between Coarse and Fine by pressing the dial. (The digit that is displayed brightly is the digit that you are setting. The Coarse and Fine digits vary depending on the model.)
5. Turn the dial to set the OCP trip point.

We are done setting the OCP trip point.

You can set or confirm the OCP trip point even when OUTPUT is turned on. In this case, if the OCP trip point voltage is set lower than the preset output current, OCP is activated and the OUTPUT turns off or the POWER switch trips.

The following conditions activate the OCP function.

- When the preset current is higher than the OCP trip point voltage.
- When the load is abnormal.
- When the unit is abnormal.

If you turn on the POWER switch without correcting the cause, OCP is activated again.

3.2.4 Unit Configuration (CONFIG)

To change various settings of the unit, use the voltmeter and ammeter, the CONFIG switch, and the dial on the front panel.

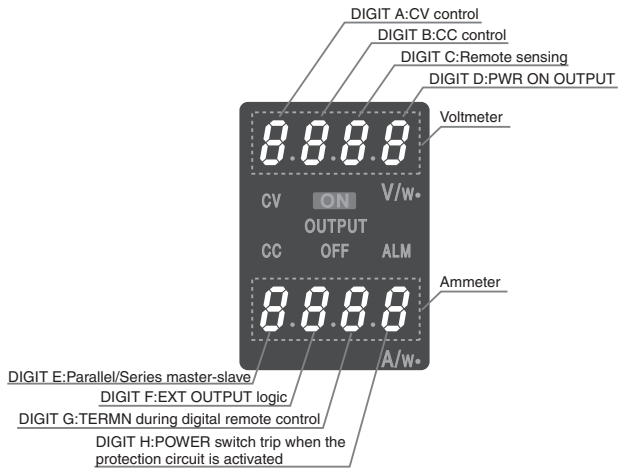

Fig.3-2 CONFIG display

Table 3-1 CONFIG settings

Voltmeter				
	DIGIT A	DIGIT B	DIGIT C	DIGIT D
Preset value	CV control	CC control	Remote sensing	PWR ON OUTPUT
0	Panel control	Panel control	OFF	OFF at startup
1	External voltage control	External voltage control	ON	ON at startup
2	External resistance control 10 kΩ → MAX OUT	External resistance control 10 kΩ → MAX OUT	——	——
3	External resistance control 10 kΩ → 0 OUT (FAIL SAFE)	External resistance control 10 kΩ → 0 OUT (FAIL SAFE)	——	——

Ammeter				
	DIGIT E	DIGIT F	DIGIT G	DIGIT H
Preset value	Parallel/Series master-slave	EXT OUTPUT logic	TERMN during digital remote control	POWER switch trip when the protection circuit is activated
0	MASTER/LOCAL	HIGH=ON	OFF	Enable(shutdown)
1	Parallel slave	LOW=ON	ON	Disable(not shutdown)
2	Series slave	——	——	——
3	——	——	——	——

■ Descriptions of setting items

CV control (DEGIT A)

Select the constant voltage control from panel control, external voltage, external resistance, and external resistance (FAIL SAFE).

For details on external control, see "4.1 Analog Remote Control".

CC control (DEGIT B)

Select the constant current control from panel control, external voltage, external resistance, and external resistance (FAIL SAFE).

For details on external control, see "4.1 Analog Remote Control".

Remote sensing (DEGIT C)

Set "0" to disable remote sensing, "1" to enable it.

For details on remote sensing, see "3.6 Remote Sensing".

PWR ON OUTPUT (DEGIT D)

Set "0" to start up the unit with the OUTPUT turned off when the POWER switch is turned on, "1" to start up the unit with the OUTPUT turned on.

Master-slave series/parallel function (DEGIT E)

Set the master and slave units when using series or master-slave parallel function. Set "0" to make the unit a maser when the master-control connection is made to the J1 connector.

Set "2" to make the unit a slave during series operation, "1" during parallel operation.

For details on master-slave series/parallel operation, see Chapter5 "Parallel and Series Operation".

EXT OUTPUT logic (DEGIT F)

When controlling the on/off of the output through an external contact (J1 connector), set "1" to turn on the OUTPUT with a low signal, "0" to turn on the OUTPUT with a high signal.

For details on the on/off control of the output using external contacts, see "4.1.6 Controlling the Output ON/OFF Using External Contact".

TERMN during digital remote control (DEGIT G)

When performing digital remote control, TERMN (termination) is set on the unit at each end of the bus.

For details on digital remote control, see "4.3 Digital Remote Control".

POWER switch trip when the protection circuit is activated (DEGIT H)

Set "0" to trip (turn off) the POWER switch when OVP (overvoltage protection), OCP (overcurrent protection), or SHUT (shut-down) is activated, "1" not to trip the POWER switch.

If set to "1" the OUTPUT is turned off when the above protection circuits are activated.

NOTE

- Precautions when setting PWR ON OUTPUT to "1"
To check the OVP operation, set the PWR ON OUTPUT to "0" (off at startup) first. Or, check the OVP operation first, and then set PWR ON OUTPUT to "1" (on at startup).
If you check the OVP operation with PWR ON OUTPUT set to "1" (on at startup) when the POWER switch trip is set to

"0" (enable), the POWER switch may turn OFF every time you turn ON the POWER switch after the initial OVP activation. This is because OVP is activated every time the power is turned on. In such case, redo the CONFIG settings.

Setup procedure

1. Turn off the POWER switch.
2. While pressing the CONFIG switch, turn on the POWER switch.

Keep pressing the CONFIG switch until the CONFIG switch lights up (CONFIG setting mode, Fig.3-2) after the version is displayed.

3. Press the VOLTAGE or CURRENT switch to move between the digits, and use the dial to enter a value between 0 and 3. The digit that is displayed brightly is the digit that is modified. You can also move between the digits by pressing the dial.

For the relationship between the position of the entered digit and the value, see table 3-1, "CONFIG settings"

(All values are factory-preset to "0.")

4. When you done with the setup, turn off the POWER switch and then turn it on again.

CONFIG settings take effect by rebooting the unit.

To escape from the CONFIG setting mode even if you are not making changes, turn off the POWER switch once.

We are done with the CONFIG settings of the unit.

You can check the settings by pressing the CONFIG switch. If you press the CONFIG switch again, the unit returns to the previous display.

3.2.5 Using the Unit as a Constant Voltage Power Supply

This section describes the procedure for using the unit as a constant voltage power supply.

1. Check that the POWER switch is turned OFF.
2. Connect the load to the output terminal.
For details on connecting the load, see "3.3 Connecting the Load".
3. Turn on the POWER switch.
4. Check that the OUTPUT OFF is illuminated.
5. Press the SET switch to enter the voltage/current setup mode.
6. Press the CURRENT switch to select Coarse or Fine for setting the current.
7. Turn the dial to set the value of the current that can flow to the load.

The value entered here becomes the current limit.

8. Press the VOLTAGE switch to select Coarse or Fine for setting the voltage.
9. Turn the dial to set the desired voltage.
10. Press the OUTPUT switch to illuminate OUTPUT ON.
11. Voltage is output to the output terminal.

OUTPUT ON and CV light up, and the voltage display shows the actual output voltage.

You can set the voltage while checking the actual output voltage even when OUTPUT ON is illuminated.

The current limit must be changed by pressing the SET switch.

-
- NOTE** • If the output current exceeds the current limit that was specified in step 7 due to load fluctuations when the unit is operating in constant voltage mode, the unit switches to constant current mode. When the unit switches to constant current mode, CC lights up.
-

3.2.6 Using the Unit as a Constant Current Power Supply

This section describes the procedure for using the unit as a constant current power supply.

1. Check that the POWER switch is turned OFF.
2. Connect the load to the output terminal.
For details on connecting the load, see "3.3 Connecting the Load".
3. Turn on the POWER switch.
4. Check that the OUTPUT OFF is illuminated.
5. Press the SET switch to enter the voltage/current setup mode.
6. Press the VOLTAGE switch to select Coarse or Fine for setting the voltage.
7. Turn the dial to set the value of the voltage that can be applied to the load.

The value entered here becomes the voltage limit.

8. Press the CURRENT switch to select Coarse or Fine for setting the current.
9. Turn the dial to set the desired current.
10. Press the OUTPUT switch to illuminate OUTPUT ON.
11. Current flows to the output terminal.

OUTPUT ON and CC light up, and the current display shows the actual output current.

You can set the current while checking the actual output current even when OUTPUT ON is illuminated.

The voltage limit must be changed by pressing the SET switch.

NOTE • If the output voltage exceeds the voltage limit that was specified in step 7 due to load fluctuations when the unit is operating in constant current mode, the unit switches to constant voltage mode. When the unit switches to constant voltage mode, CV lights up.

3.3 Connecting the Load

This section describes the load cable used to connect the unit and the load and the connection to the output terminal.

3.3.1 Load Cable

-
-  **WARNING**
- To prevent the possibility of fire, use a load cable with sufficient current capacity with respect to the rated output current of the unit.
 - To prevent the possibility of electric shock, use a load cable with a higher voltage rating than the isolation voltage of the unit.
For details on the isolation voltage of each model, see Chapter 8 "Specifications".
-

Current capacity of load cables

Load cables must be rated to carry the maximum rated output current of the unit. If their current rating exceeds the maximum rated output current, the cable will remain intact even if the load is short-circuited.

The allowable current of a wire is determined by the maximum allowable temperature of the cable insulation, which in turn is governed by a current-caused resistance loss, ambient temperature, and thermal resistance to the outside. The allowable currents in table 3-2 show the capacity of current flowing through a heat-resistant PVC wire (single wire) having a maximum allowable temperature of 60 °C when the wire is stretched horizontally in the air at an ambient temperature of 30 °C. If the condition is such that PVC wires with lower heat-resistant temperature are used, ambient temperature exceeds 30 °C, or the wires are bundled resulting in low heat radiation, the current capacity needs to be reduced.

Based on this consideration, it is better to make heat radiation as great as possible to allow a larger current to flow, as long as wires having the same heat-resistant temperature are used. For measures against noise in the load cables, however, installing the + (pos.) and - (neg.) output lines side by side or bundling them together is more effective against unwanted noise. The Kikusui-recommended currents shown in table 3-2 are allowable current values that have been reduced in consideration of the potential bundling of load cables. Use these values as a guideline when installing load wires.

Because wires have resistance, voltage drop in wires becomes greater as the wire becomes longer or the current becomes larger. This causes the voltage applied at the load end to be smaller. The PAS series power supplies have a sensing function that compensates for this voltage drop. Compensation of up to approximately 0.6 V is available for a single line. If the voltage drop exceeds this level, wires having a greater cross-sectional area should be used.

Table 3-2 Nominal cross-sectional area of cables and allowable currents

Nominal cross-sectional area [mm]	AWG	(Reference cross-sectional area) [mm]	Allowable current*1 [A] (Ta = 30°C)	Current recommended by Kikusui [A]
2	14	(0.28)	27	10
3.5	12	(3.31)	37	-
5.5	10	(5.26)	49	20
8	8	(8.37)	61	30
14	6	(13.3)	88	50
22	4	(21.15)	115	80
30	2	(33.62)	139	-
38	1	(42.41)	162	100
50	1/0	(53.49)	190	-
60	2/0	(67.43)	217	-
80	3/0	(85.01)	257	200
100	4/0	(107.2)	298	-
125	-	-	344	-
150	-	-	395	300
200	-	-	469	-

*1. Excerpts from Japanese laws related to electrical equipment.

Withstand voltage of load cables

For load cables, use cables with a higher voltage rating than the isolation voltage of the unit. In particular, if the rated voltage of load cables is lower than the isolation voltage of the power supply having a rated output voltage of 40 V or more, electric shock may occur.

For details on the isolation voltage and the insulation, see "2.5 Grounding the Output Terminal"

3.3.2 Connecting to the Output Terminals

⚠ WARNING • Possible electric shock. Be sure to turn the POWER switch off before touching the output terminal on the rear panel. Be sure to attach the OUTPUT terminal cover after wiring the load.

The chassis connection wire is not included. If you are using the chassis connection wire that comes with the analog remote control connector kit (OP01-PAS), you can use it immediately as it is already assembled.

1. Turn the POWER switch off.
2. Connect the chassis terminal to either the - (neg.) or + (pos.) output terminal using the chassis connection wire.

The output terminal has an M3 hole used to connect the chassis connection wire.

If you are not using the optional OP01-PAS, attach a crimping terminal to a wire of AWG18 or higher to make the connection.

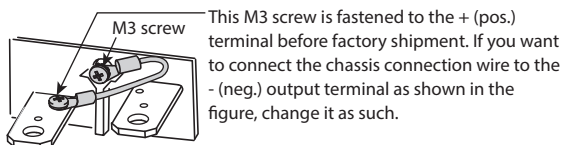

Fig.3-3 Connection of the chassis connection wire
(example in which the - (neg.) output terminal is connected)

3. Attach crimping terminals to the load wires.

The output terminal on the rear panel has M4- (with taps) and M8-sized holes for connecting the load wires. Attach the crimping terminal that matches the screws.

Use crimping terminals that are less than equal to 5.5 mm² with the M4-sized holes.

4. Connect the load wire to the output terminal on the rear panel.

If you are using M8 screws, pay attention to the direction of the screws.

Connection using M4 screws

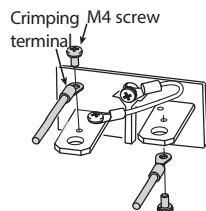

Do not fasten M4 screw without attaching the load wire. Otherwise the threads of the output terminal may be damaged.

Connection using M8 screws

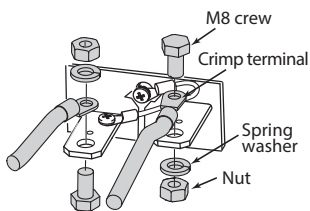

If you do not connect the wire as shown, the OUTPUT terminal cover may hit the M8 screw.

Fig.3-4 Connecting the load wire to the output terminal on the rear panel

Attaching the OUTPUT terminal cover

There are two types of OUTPUT terminal covers: bottom cover and top cover.

1. Insert the hook of the bottom cover into the hole located above and to the left of the output terminal.

The bottom cover is the one without screws.

2. Align the hook of the bottom cover to the groove located to the side of the output terminal.
3. Align the bottom cover with the top cover, and fix them in place using the screws attached to the top cover.

Check that the screws are securely fastened.

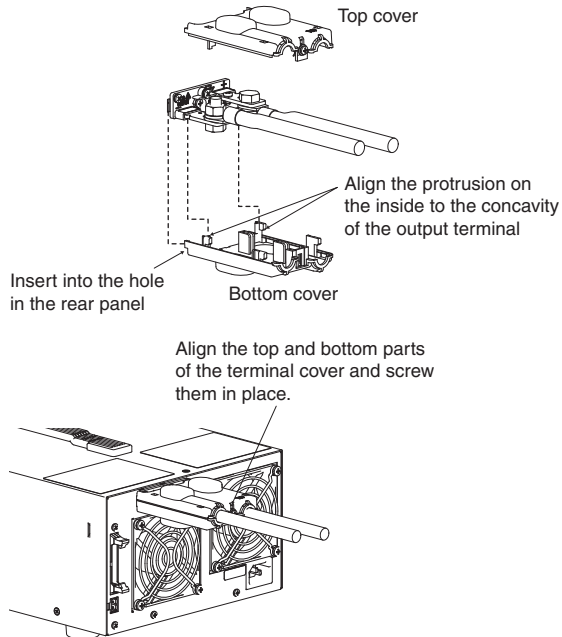

Fig.3-5 Attachment of the OUTPUT terminal cover

3.4 Switching the Power Display

The PAS series power supply allow you to vary the output voltage or output current while checking the output power.

When varying the output voltage while checking the power

If you press the SHIFT+CURRENT switch (press the CURRENT switch while pressing the SHIFT switch) when the OUTPUT is on, the current display shows the output power.

The LED to the right of the unit lights up when power is being displayed.

In this condition, select Coarse or Fine using the VOLTAGE switch and vary the voltage using the dial.

To clear the power display, press the SHIFT+CURRENT (or SET) switch again.

When varying the output current while checking the power

If you press the SHIFT+VOLTAGE switch (press the VOLTAGE switch while pressing the SHIFT switch), the voltage display shows the output power.

The LED to the right of the unit lights up when power is being displayed.

In this condition, select Coarse or Fine using the CURRENT switch and vary the voltage using the dial.

To clear the power display, press the SHIFT+VOLTAGE (or SET) switch again.

Switching the display position

Once the power is displayed, you can switch the power display position using the VOLTAGE or CURRENT switch.

3.5 LOCK Function

A LOCK switch is provided as a function to prevent inadvertently changing the settings.

When the panel lock is enabled (LOCK switch lights up), the switches on the front panel (excluding the OUTPUT switch) and the dial do not function.

Panel lock procedure

1. Configure necessary all settings such as the output voltage.
2. Press the LOCK switch.

The LOCK switch lights up, and the panel lock is enabled.

To clear the panel lock, press the LOCK switch again.

3.6 Remote Sensing

The remote sensing function is used to reduce the influence of voltage drops due to the load cable resistance and stabilize the output voltage across the load.

The remote sensing function of this unit can compensate up to approximately 0.6 V for a single line. Select a load cable with sufficient current capacity so that the voltage drop of the load cable does not exceed the compensation voltage.

To perform remote sensing, an electrolytic capacitor is required at the sensing point (load terminal).

-
- NOTE** • The voltage drop compensation is approximately 0.6 V for a single line. However, if remote sensing is performed near the maximum output voltage, the output of the unit is limited by the maximum voltage (105 % of the rated output voltage).
-

Sensing wire connection procedure

-
- ⚠ WARNING** • Never connect wires to the sensing terminals while the POWER switch is turned on. Such acts can cause electric shock or damage to the internal circuitry.
-

1. Press the POWER switch while pressing the CONFIG switch to enter the CONFIG setting mode.

Turn on remote sensing through CONFIG setting.

For details on CONFIG settings, see "3.2.4 Unit Configuration (CONFIG)".

2. Turn off the POWER switch.
3. As shown in Fig.3-6, connect the sensing wires between the sensing terminals and the load cable by using the screws provided.

To decrease output ripple voltages resulting from inductive effects, use a 2-core shielded wire for the sensing wires. Connect the shield to the - (neg.) terminal.

If you cannot use shielded wires, twist the + (pos.) and - (neg.) wires thoroughly.

⚠ WARNING

- For sensing cables, use cables with a higher voltage rating than the isolation voltage of the unit. For details, see "2.5 Grounding the Output Terminal" Protect the uncovered section of the shielded wire by using insulation tubes with a withstand voltage greater than the isolation voltage of the unit.
- To turn on/off the power supplied to a load using a mechanical switch, provide additional switches between the sensing wires as shown in Fig.3-7 and turn on/off the power and remote sensing cables simultaneously. Be sure to turn off the OUTPUT switch or POWER switch before turning on/off the mechanical switch.

⚠ CAUTION

- If the sensing wires come loose, the output voltage across the load cannot be stabilized and may cause excessive voltage to be applied to the load. Securely connect the sensing wires such as by using crimp terminals.
-

4. As necessary, connect an electrolytic capacitor (C) between 0.1 μ F to several hundred μ F across the load terminals.

⚠ CAUTION • Use a capacitor (C) whose withstand voltage is greater than or equal to 120 % of the unit's rated voltage.

- NOTE**
- If the wiring to a load is long, the phase shift caused by the inductance and capacitance of the wiring becomes non-negligible, thereby causing oscillation. In such case, the capacitor (C) prevents oscillation.
 - If the load current changes suddenly to pulse form, the output voltage may increase due to the effects from the inductance component of the wiring. In such case, the capacitor (C) also prevents variations in output.
 - In addition, twisting the load wires reduces the inductance component, thereby stabilizing the output.
-

5. Check the sensing wire connection and CONFIG settings again.

⚠ CAUTION • When you are done using the remote sensing function, remove the sensing wires, and be sure to turn off remote sensing in the CONFIG settings.

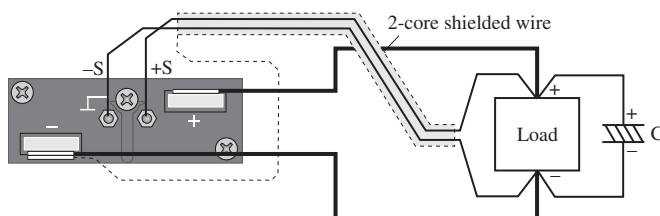

Fig.3-6 Remote sensing connection

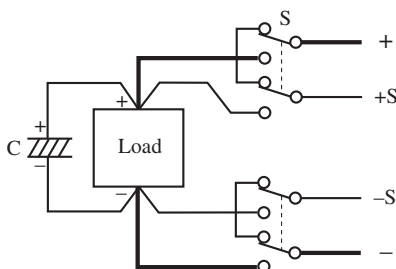

Fig.3-7 Power on/off using mechanical switches

This page has been intentionally left blank.

This chapter describes the remote control function of the unit. Please read the warnings and cautions thoroughly before operation. There are two main methods for remotely controlling the unit.

- Analog remote control
- Digital remote control

In analog remote control, the power supply and contacts that are connected to the J1 connector on the rear panel are used to control the unit.

In digital remote control, the PIA4830, PIA4850 or PIA4810 Power Supply Controller that is connected to the TP-BUS connector on the rear panel is used to control the unit.

For details on the PIA4800 series Power Supply Controller, see the manual of the respective product. For connection to a Power Supply and device messages, refer to the “Connecting & Programming Guide” in the CD-ROM that came with the PIA4800 series.

If you are using the PIA3200 Power Supply Controller, contact your Kikusui agent/distributor.

4.1 Analog Remote Control

The J1 connector on the rear panel can be used to control the unit in the following manner.

- Control the output voltage using external voltage
- Control the output current using external voltage
- Control the output voltage using external resistance
- Control the output current using external resistance
- On/off control of the output using external contact
- Shutdown control using external contact
(turn off the OUTPUT or POWER switch)

4.1.1 About the J1 Connector



- The J1 connector contains pins that are at the same electric potential as the output terminal. If you are not using the J1 connector, to prevent the possibility of electric shock, be sure to insert the protective socket provided.
- To prevent the possibility of electric shock, be sure to use the protective cover on the sockets.

The connector parts needed to connect the J1 connector (standard MIL connector) are not provided. table 4-1 shows the tools and parts that are needed.

For information on how to obtain the tools and parts, contact your Kikusui agent or distributor.

An optional OP01-PAS Analog Remote Control Connector Kit is available for making the connection.

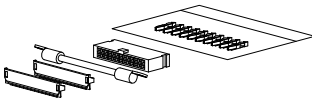

Fig.4-1 OP01-PAS

Table 4-1 Connector parts by Omron needed to connect the J1 connector

Product	Model	Kikusui Parts No.	Notes
Single contact connection tool	XY2B-7006	Y2-070-001	—
Contact removal tool	XY2E-0001	Y2-070-002	—
Pin (contact)	XG5W-0031	84-49-0100	Recommended wire size AWG24 (UL-1061)
Socket	XG5M-2632-N	84-49-0160	MIL standard type socket
Protection cover	XG5S-1301	84-49-0161	—

For details on how to use the tools, read the catalog by Omron.

Table 4-2 J1 connector arrangement

Pin No.	Signal Name	Description
1	A COM	Connected to the negative electrode (-S) of the sensing input when remote sensing is used; connected to - (neg.) output when remote sensing is not used.
2	D COM	Connected to the negative electrode (-S) of the sensing input when remote sensing is used; connected to - (neg.) output when remote sensing is not used.
3	OUT ON/OFF CONT	OUTPUT ON/OFF Output off at LOW (or HIGH) level The internal circuit is pulled up to + 5 V through 10 k Ω .
4	EXT-V CV CONT	External voltage control of the output voltage (0 % to 100 % of the rated output voltage in the range of 0 V to 10 V)
5	EXT-V CC CONT	External voltage control of the output current (0 % to 100 % of the rated output current in the range of 0 V to 10 V)
6	EXT-R CV CONT	External resistance control of the output voltage (1) 0 % to 100 % of the rated output voltage in the range of 0 k Ω to 10 k Ω or (2) 100 % to 0 % of the rated output voltage in the range of 0 k Ω to 10 k Ω
7	EXT-R CC CONT	External resistance control of the output current (1) 0 % to 100 % of the rated output current in the range of 0 k Ω to 10 k Ω or (2) 100 % to 0 % of the rated output current in the range of 0 k Ω to 10 k Ω
8	VMON	Output voltage monitor (Outputs the 0 % to 100 % range of the rated voltage using 0 V to 10 V)
9	IMON	Output current monitor (Outputs the 0 % to 100 % range of the rated current using 0 V to 10 V)
10	SHUT DOWN	Shutdown OUTPUT or POWER switch off at LOW level The internal circuit is pulled up to + 5 V through 10 k Ω .
11	SER IN+	Positive electrode input terminal during master-slave series operation.
12	PRL IN+	Positive electrode input terminal during master-slave parallel operation.
13	SER IN-	Negative electrode input terminal during master-slave series operation.
14	PRL IN [COMP IN] *1	Negative electrode input terminal during master-slave parallel operation. [Compensation signal input terminal during master-slave parallel operation]
15	NEXT PRL OUT+	Positive electrode output terminal to the next device during master-slave parallel operation.
16	NEXT PRL OUT- [NEXT COMP OUT] *1	Negative electrode output terminal to the next device during master-slave parallel operation. [Compensation signal output terminal to the next device during master-slave parallel operation]
17	STATUS COM	Common for status signals from pin 18 through 22.

Pin No.	Signal Name	Description
18	CV STATUS	Turns ON during CV operation (open collector output by a photo-coupler) *2
19	CC STATUS	Turns ON during CC operation. (open collector output by a photo-coupler) *2
20	ALM STATUS	Turns on when OVP, OCP, or OHP is activated or when a shutdown signal is input.,(open collector output by a photocoupler, held for approx. 0.5 s when the POWER switch is turned off) *2
21	OUT ON STATUS	Turns on when OUTPUT is turned on. (open collector output by a photocoupler) *2
22	PWR OFF STATUS	Turns on when the internal sub power supply is activated with the POWER switch turned off. (open collector output by a photocoupler, held for approx. 0.5 s) *2
23	SER OUT+	Positive electrode output terminal during master-slave series operation.
24	PRL OUT+	Positive electrode output terminal during master-slave parallel operation.
25	SER OUT-	Negative electrode output terminal during master-slave series operation.
26	PRL OUT- [COMP OUT] *1	Negative electrode output terminal during master-slave parallel operation. [Compensation signal output terminal during master-slave parallel operation]

*1. Items inside brackets are for the 160 V, 320 V, and 500 V models.

*2. Open collector output (maximum voltage of 30 V and maximum current of 8 mA).
It is insulated from the control circuit.

4.1.2 Controlling the Output Voltage Using External Voltage

This method is used to control the output voltage using an external voltage (V_{ext}) in the range 0 V to approx. 10 V.

To control the output voltage using external voltage, you must set CV control of CONFIG settings to "1." For details on CONFIG settings, see "3.2.4 Unit Configuration (CONFIG)".

Press the SET switch to check the preset voltage.



WARNING • The insulation of the external voltage source (V_{ext}) and the cable connecting it should be greater than the isolation voltage of the unit. For details on the isolation voltage of each model, see Chapter8 "Specifications".

In addition, leave the output of the external voltage source (V_{ext}) floating. For details, see "2.5 Grounding the Output Terminal".

- When using shielded wires for connection, protect the uncovered section of the shielded wire by using insulation tubes with a withstand voltage greater than the isolation voltage of the unit.
-

The output voltage (E_o) varies in the range of 0 to rated output voltage by setting the external voltage (V_{ext}) in the range of 0 V to 10 V.

$$E_o = E_{rtg} \cdot V_{ext} / 10 \text{ [V]} \qquad V_{ext} = 10 \cdot E_o / E_{rtg} \text{ [V]}$$

E_{rtg} : Rated output voltage [V]

For a portion of the 10 V, 20 V, 40 V, 60 V, and 80 V models, the products may be manufactured under the following specifications. See also Chapter8 "Specifications".

The output voltage (E_o) varies in the range of 0 to rated output voltage by setting the external voltage (V_{ext}) in the range of approx. 0 V [0.5 V] to 10 V [9.5 V]. (The value inside brackets is the design value.)

$$E_o = E_{rtg} \cdot (V_{ext} - 0.5) / 9 \text{ [V]} \qquad V_{ext} = (E_o / E_{rtg} \cdot 9) + 0.5 \text{ [V]}$$

$$0.5 \leq V_{ext} \leq 9.5 \text{ [V]}$$

E_{rtg} : Rated output voltage [V]

-
- CAUTION**
- Make sure the polarity of Vext is correct. Otherwise, damage to the unit may result.
 - Do not apply voltage or reverse voltage exceeding 10.5 V across the external voltage control pins. Otherwise, damage to the unit may result.
-

- NOTE**
- The input impedance across the external voltage control pins is approximately 30 k Ω .
 - Use a low-noise and stable voltage source for Vext. The noise in Vext is multiplied by the amplification factor of the unit and appears at the unit's output. Thus, the output ripple noise may not meet the unit's specifications.
 - To minimize the influence of noise on the output, use a 2-core shielded wire or a twisted-pair wire to connect the control terminals and Vext. Make the wires as short as possible. Susceptibility to the effects of noise increases as the wires get longer. When wires are long, proper operation may be hindered even if a cable with anti-noise measures is used. When using a shielded cable, connect the shield to the - (neg.) output terminal. If the shield needs to be connected to the Vext side, see next page "Connecting the Shield to the Vext Side".
-

External voltage source (Vext) connection

Pins 1 and 4 of the J1 connector are used.

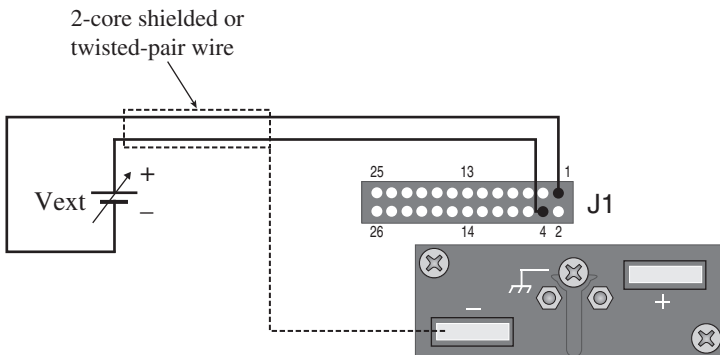

Fig.4-1 Connection of the output voltage control using external voltage

Connecting the Shield to the Vext Side

⚠ CAUTION • If you are connecting the shield to the Vext side when using external voltage control, do not connect the shield to the - (neg.) output terminal of the unit.

When using shielded wires, some external voltage sources may require that the shield be connected to the external voltage source (Vext). In such case, the grounding method used for Vext and the unit creates a condition in which the output is short-circuited, as shown in Fig.4-2. Thus, do not connect the shield to the - (neg.) output terminal of the unit.

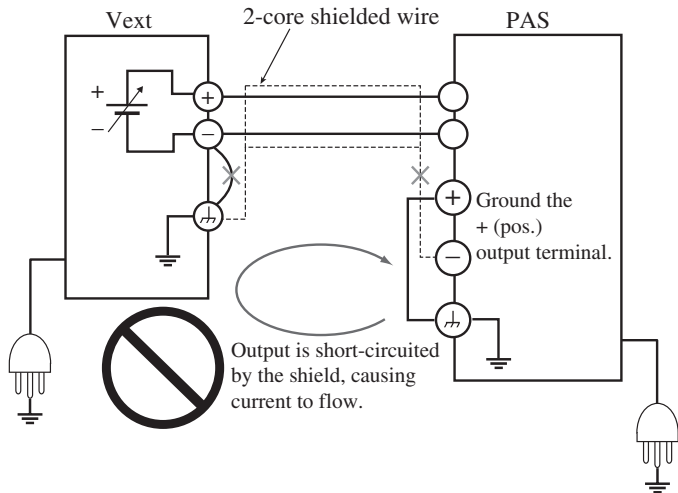

Fig.4-2 A connection in which the output is short-circuited by the shield

⚠ WARNING • Leave the output of the external voltage source (Vext) floating. The potential of the J1 connector is nearly equal to the - (neg.) output terminal, and short-circuit current flows to the signal line even without the shield.

4.1.3 Controlling the Output Voltage Using External Resistance

This method is used to control the output voltage using an external resistance (R_{ext}) in the range 0 k Ω to approx. 10 k Ω .



- The insulation of the external resistor (R_{ext}) and the cable connecting it should be greater than the isolation voltage of the unit. For details on the isolation voltage of each model, see Chapter8 "Specifications".
 - When using shielded wires for connection, protect the uncovered section of the shielded wire by using insulation tubes with a withstand voltage greater than the isolation voltage of the unit.
-

You can select the following two types of modes through CONFIG settings. For details on CONFIG settings, see "3.2.4 Unit Configuration (CONFIG)".

Press the SET switch to check the preset voltage.

10 k Ω → MAX OUT CV mode

The output voltage (E_o) varies in the range of 0 to rated output voltage by setting the external resistance (R_{ext}) in the range of 0 k Ω to 10 k Ω .

$$E_o = E_{rtg} \cdot R_{ext} / 10 \text{ [V]} \quad R_{ext} = 10 \cdot E_o / E_{rtg} \text{ [V]}$$

E_{rtg} : Rated output voltage [V]

10 k Ω → 0 OUT CV mode (FAIL SAFE)

The output voltage (E_o) varies in the range of rated output voltage to 0 by setting the external resistance (R_{ext}) in the range of 0 k Ω to 10 k Ω .

$$E_o = E_{rtg} \cdot (10 - R_{ext}) / 10 \text{ [V]} \quad R_{ext} = 10 \cdot (E_{rtg} - E_o) / E_{rtg} \text{ [V]}$$

E_{rtg} : Rated output voltage [V]

For a portion of the 10 V, 20 V, 40 V, 60 V, and 80 V models, the products may be manufactured under the following specifications. See also Chapter8 "Specifications".

10 kΩ → MAX OUT CV mode

The output voltage (E_o) varies in the range of 0 to rated output voltage by setting the external resistance (R_{ext}) in the range of approx. 0 kΩ [0.5 kΩ] to 10 kΩ [9.5 kΩ]. (The value inside brackets is the design value.)

$$E_o = E_{rtg} \cdot (R_{ext} - 500) / 9000 \text{ [V]} \quad R_{ext} = (E_o / E_{rtg} \cdot 9000) + 500 \text{ [Ω]}$$
$$500 \leq R_{ext} \leq 9500 \text{ [Ω]}$$

E_{rtg} : Rated output voltage [V]

10 kΩ → 0 OUT CV mode (FAIL SAFE)

The output voltage (E_o) varies in the range of rated output voltage to 0 by setting the external resistance (R_{ext}) in the range of approx. 0 kΩ [0.5 kΩ] to 10 kΩ [9.5 kΩ]. (The value inside brackets is the design value.)

$$E_o = E_{rtg} \cdot (9500 - R_{ext}) / 9000 \text{ [V]} \quad R_{ext} = 9500 - (E_o / E_{rtg} \cdot 9000) \text{ [Ω]}$$
$$500 \leq R_{ext} \leq 9500 \text{ [Ω]}$$

E_{rtg} : Rated output voltage [V]

-
- ⚠ CAUTION**
- If R_{ext} comes loose when using the 10 kΩ → MAX OUT CV mode, excessive voltage may be applied to the load. For your safety, it is recommended that fail-safe 10 kΩ → 0 OUT CV mode be used.
 - If you are using fixed resistors for R_{ext} and controlling the output voltage by switching through them, use a short-circuit or continuous type switch.
-

- NOTE**
- For R_{ext} , use a 1/2 W or larger metal film or wire-wound resistor with good temperature coefficient and small aging effect.
 - To minimize the influence of noise on the output, use a 2-core shielded wire or a twisted-pair wire to connect the control terminals and R_{ext} . Make the wires as short as possible. Susceptibility to the effects of noise increases as the wires get longer. When wires are long, proper operation may be hindered even if a cable with anti-noise measures is used. When using a shielded cable, connect the shield to the - (neg.) output terminal.
-

■ External resistor (R_{ext}) connection

Pins 1 and 6 of the J1 connector are used.

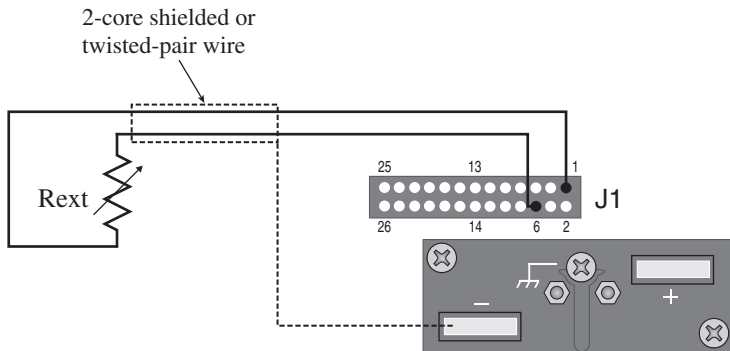

Fig.4-3 Connection of the output voltage control using external resistance

4.1.4 Controlling the output current using external voltage

This method is used to control the output current using an external voltage (V_{ext}) in the range 0 V to approx. 10 V.

To control the output current using external voltage, you must set CC control of CONFIG settings to "1." For details on CONFIG settings, see "3.2.4 Unit Configuration (CONFIG)".

Press the SET switch to check the preset current.

-
- ⚠ WARNING** • The insulation of the external voltage source (V_{ext}) and the cable connecting it should be greater than the isolation voltage of the unit. For details on the isolation voltage of each model, see Chapter8 "Specifications".
- In addition, leave the output of the external voltage source (V_{ext}) floating. For details, see "2.5 Grounding the Output Terminal".
- When using shielded wires for connection, protect the uncovered section of the shielded wire by using insulation tubes with a withstand voltage greater than the isolation voltage of the unit.
-

The output current (I_o) varies in the range of 0 to rated output current by setting the external voltage (V_{ext}) in the range of 0 V to 10 V.

$$I_o = I_{rtg} \cdot V_{ext} / 10 \text{ [A]} \qquad V_{ext} = 10 \cdot I_o / I_{rtg} \text{ [V]}$$

I_{rtg} : Rated output current [A]

For a portion of the 10 V, 20 V, 40 V, 60 V, and 80 V models, the products may be manufactured under the following specifications. See also Chapter8 "Specifications".

The output current (I_o) varies in the range of 0 to rated output current by setting the external voltage (V_{ext}) in the range of approx. 0 V [0.5 V] to 10 V [9.5 V]. (The value inside brackets is the design value.)

$$I_o = I_{rtg} \cdot (V_{ext} - 0.5) / 9 \text{ [A]} \qquad V_{ext} = (I_o / I_{rtg} \cdot 9) + 0.5 \text{ [V]}$$

$$0.5 \leq V_{ext} \leq 9.5 \text{ [V]}$$

I_{rtg} : Rated output current [A]

-
- ⚠ CAUTION** • Make sure the polarity of V_{ext} is correct. Otherwise, damage to the unit may result.

- If Vext comes loose, erroneous operation may result due to external noise. Securely connect the wires to the J1 connector.
- Do not apply voltage or reverse voltage exceeding 10.5 V across the external voltage control pins. Otherwise, damage to the unit may result.

NOTE

- The input impedance across the external voltage control pins is approximately 30 kΩ.
- Use a low-noise and stable voltage source for Vext. The noise in Vext is multiplied by the amplification factor of the unit and appears at the unit's output. Thus, the output ripple noise may not meet the unit's specifications.
- To minimize the influence of noise on the output, use a 2-core shielded wire or a twisted-pair wire to connect the control terminals and Vext. Make the wires as short as possible. Susceptibility to the effects of noise increases as the wires get longer. When wires are long, proper operation may be hindered even if a cable with anti-noise measures is used. When using a shielded cable, connect the shield to the - (neg.) output terminal. If the shield needs to be connected to the Vext side, see next page "Connecting the Shield to the Vext Side".

External voltage source (Vext) connection

Pins 1 and 5 of the J1 connector are used.

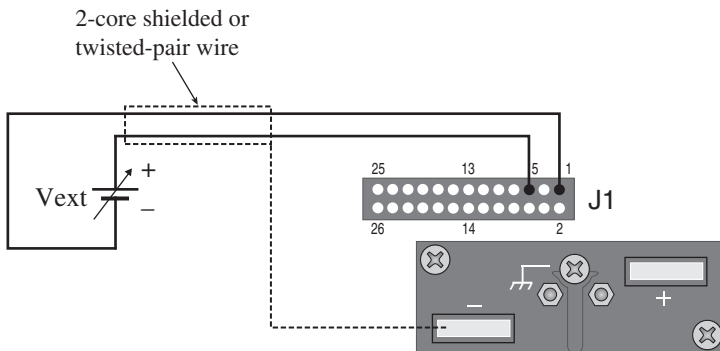

Fig.4-4 Connection of the output current control using external voltage

Connecting the Shield to the Vext Side

⚠ CAUTION • If you are connecting the shield to the Vext side when using external voltage control, do not connect the shield to the - (neg.) output terminal of the unit.

When using shielded wires, some external voltage sources may require that the shield be connected to the external voltage source (Vext). In such case, the grounding method used for Vext and the unit creates a condition in which the output is short-circuited, as shown in Fig.4-5. Thus, do not connect the shield to the - (neg.) output terminal of the unit.

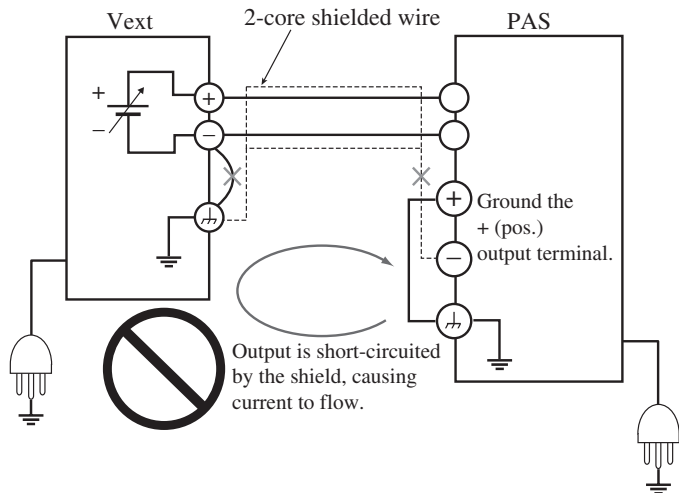



Fig.4-5 A connection in which the output is short-circuited by the shield

⚠ WARNING • Leave the output of the external voltage source (Vext) floating. The potential of the J1 connector is nearly equal to the - (neg.) output terminal, and short-circuit current flows to the signal line even without the shield.

4.1.5 Controlling the Output Current Using External Resistance

This method is used to control the output current using an external resistance (R_{ext}) in the range 0 k Ω to approx. 10 k Ω .

Press the SET switch to check the preset current.

-
-  **WARNING** • The insulation of the external resistor (R_{ext}) and the cable connecting it should be greater than the isolation voltage of the unit. For details on the isolation voltage of each model, see Chapter 8 "Specifications".
- When using shielded wires for connection, protect the uncovered section of the shielded wire by using insulation tubes with a withstand voltage greater than the isolation voltage of the unit.
-

You can select the following two types of modes through CONFIG settings. For details on CONFIG settings, see "3.2.4 Unit Configuration (CONFIG)".

10 k Ω → MAX OUT CC mode

The output current (I_o) varies in the range of 0 to rated output current by setting the external resistance (R_{ext}) in the range of 0 k Ω to 10 k Ω .

$$I_o = I_{rtg} \cdot R_{ext} / 10 \text{ [A]} \qquad R_{ext} = 10 \cdot I_o / I_{rtg} \text{ [A]}$$

I_{rtg} : Rated output current [A]

10 k Ω → 0 OUT CC mode (FAIL SAFE)

The output current (I_o) varies in the range of rated output current to 0 by setting the external resistance (R_{ext}) in the range of 0 k Ω to 10 k Ω .

$$I_o = I_{rtg} \cdot (10 - R_{ext}) / 10 \text{ [A]} \qquad R_{ext} = 10 \cdot (I_{rtg} - I_o) / I_{rtg} \text{ [A]}$$

I_{rtg} : Rated output current [A]

For a portion of the 10 V, 20 V, 40 V, 60 V, and 80 V models, the products may be manufactured under the following specifications. See also Chapter8 "Specifications".

10 kΩ → MAX OUT CC mode

The output current (I_o) varies in the range of 0 to rated output current by setting the external resistance (R_{ext}) in the range of approx. 0 kΩ [0.5 kΩ] to 10 kΩ [9.5 kΩ]. (The value inside brackets is the design value.)

$$I_o = I_{rtg} \cdot (R_{ext} - 500) / 9000 \text{ [A]} \quad R_{ext} = (I_o / I_{rtg} \cdot 9000) + 500 \text{ [}\Omega\text{]}$$

$$500 \leq R_{ext} \leq 9500 \text{ [}\Omega\text{]}$$

I_{rtg} : Rated output current [A]

10 kΩ → 0 OUT CC mode (FAIL SAFE)

The output current (I_o) varies in the range of rated output current to 0 by setting the external resistance (R_{ext}) in the range of approx. 0 kΩ [0.5 kΩ] to 10 kΩ [9.5 kΩ]. (The value inside brackets is the design value.)

$$I_o = I_{rtg} \cdot (9500 - R_{ext}) / 9000 \text{ [A]} \quad R_{ext} = 9500 - (I_o / I_{rtg} \cdot 9000) \text{ [}\Omega\text{]}$$

$$500 \leq R_{ext} \leq 9500 \text{ [}\Omega\text{]}$$

I_{rtg} : Rated output current [A]

-
- ⚠ CAUTION**
- If R_{ext} comes loose when using the 10 kΩ → MAX OUT CC mode, excessive current may flow through the load. For your safety, it is recommended that fail-safe 10 kΩ → 0 OUT CC mode be used.
 - If you are using fixed resistors for R_{ext} and controlling the output voltage by switching through them, use a short-circuit or continuous type switch.
-

- NOTE**
- For R_{ext} , use a 1/2 W or larger metal film or wire-wound resistor with good temperature coefficient and small aging effect.
 - To minimize the influence of noise on the output, use a 2-core shielded wire or a twisted-pair wire to connect the control terminals and R_{ext} . Make the wires as short as possible. Susceptibility to the effects of noise increases as the wires get longer. When wires are long, proper operation may be hindered even if a cable with anti-noise measures is used. When using a shielded cable, connect the shield to the - (neg.) output terminal.
-

■ External resistor (R_{ext}) connection

Pins 1 and 7 of the J1 connector are used.

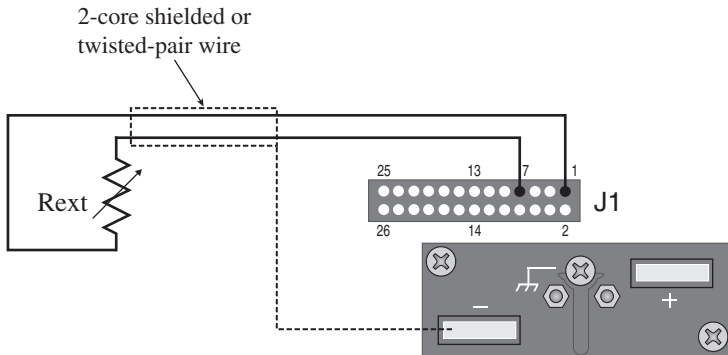

Fig.4-6 Connection of the output current control using external resistance

4.1.6 Controlling the Output ON/OFF Using External Contact

This method is used to control the output on/off status using external contacts.

You can select the following two types of modes through CONFIG settings. For details on CONFIG settings, see "3.2.4 Unit Configuration (CONFIG)".

LOW=ON mode

OUTPUT turns on when pin 3 of the J1 connector is set LOW level*¹.

HIGH=ON mode

OUTPUT turns on when pin 3 of the J1 connector is set HIGH level*².

*¹LOW level: Means shorting pins 2 and 3 of the J1 connector, or applying 0 V to pins 2 (common) and 3.

*²HIGH level: Means opening pins 2 and 3 of the J1 connector, or applying 3.5 V to 5 V to pins 2 (common) and 3.

When the external contact is in the OUTPUT ON condition, the OUTPUT switch on the front panel is valid.

If you wish to turn on the output using external contact after you have turned off the output using the OUTPUT switch on the front panel, set the external contact to the OUTPUT OFF condition once and then set it to the OUTPUT ON condition again. When the external contact is in the OUTPUT OFF condition, the OUTPUT switch on the front panel is invalid.

■ ON/OFF control connection

Pins 2 and 3 of the J1 connector are used.

Use parts with a contact rating of 5 VDC and 10 mA or more for the external contact.

To minimize the influence of noise on the output, use a 2-core shielded wire or a twisted-pair wire to connect the control terminals and the external contact. Make the wires as short as possible. Susceptibility to the effects of noise increases as the wires get longer. When wires are long, proper operation may be hindered even if a cable with anti-noise measures is used.

When using a shielded cable, connect the shield to the - (neg.) output terminal.

-
- NOTE**
- If multiple units are used under floating conditions and a single external contact is used to turn on/off the output, ground the negative outside of each power supply unit. Or, use relays or similar devices for the external contact signal to isolate the signal flowing through each unit.
-

- WARNING**
- The insulation of the external contact (S) and the cable connecting it should be greater than the isolation voltage of the unit. For details on the isolation voltage of each model, see Chapter8 "Specifications".
 - When using shielded wires for connection, protect the uncovered section of the shielded wire by using insulation tubes with a withstand voltage greater than the isolation voltage of the unit.
-

- NOTE**
- The release voltage across pins 3 and 2 is approx. $5\text{ V} \pm 5\%$ maximum, and the short circuit current is approx. $500\ \mu\text{A} \pm 5\%$ maximum. (The internal circuit is pulled up to 5 V through 10 k Ω .)
 - When wiring over a great distance, use a small relay and extend the coil side of that relay.
-

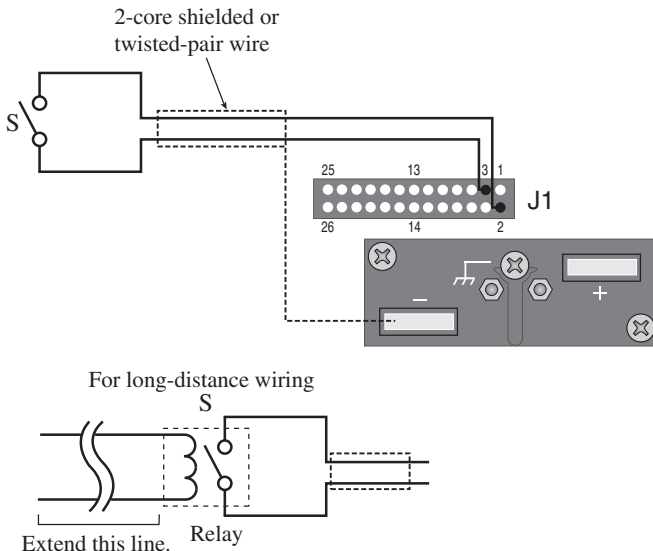

Fig.4-7 ON/OFF control connection

4.1.7 Controlling the Output Shutdown Using External Contact

This method is used to control the output shutdown using external contacts.

You can select the following two types of modes through CONFIG settings. For details on CONFIG settings, see "3.2.4 Unit Configuration (CONFIG)".

When POWER switch trip setting is enabled

The POWER switch trips when pin 10 of the J1 connector is set LOW level^{*1}.

To recover, set pin 10 HIGH level^{*2}, and turn on the POWER switch.

When POWER switch trip setting is disabled

The OUTPUT turns off when pin 10 of the J1 connector is set LOW level. (The POWER switch is not tripped.)

To recover, set pin 10 HIGH level, turn off on the POWER switch, and turn it back on.

^{*1}LOW level: Means shorting pins 2 and 10 of the J1 connector, or applying 0 V to pins 2 (common) and 3.

^{*2}HIGH level: Means opening pins 2 and 10 of the J1 connector, or applying 3.5 V to 5 V to pins 2 (common) and 3.

■ Shutdown control connection

Pins 2 and 10 of the J1 connector are used.

Use parts with a contact rating of 5 VDC and 10 mA or more for the external contact.

To minimize the influence of noise on the output, use a 2-core shielded wire or a twisted-pair wire to connect the control terminals and the external contact. Make the wires as short as possible. Susceptibility to the effects of noise increases as the wires get longer. When wires are long, proper operation may be hindered even if a cable with anti-noise measures is used.

When using a shielded cable, connect the shield to the - (neg.) output terminal.

- ⚠ WARNING**
- The insulation of the external contact (S) and the cable connecting it should be greater than the isolation voltage of the unit. For details on the isolation voltage of each model, see Chapter 8 "Specifications".
 - When using shielded wires for connection, protect the uncovered section of the shielded wire by using insulation tubes with a withstand voltage greater than the isolation voltage of the unit.

- NOTE**
- The release voltage across pins 10 and 2 is approx. $5\text{ V} \pm 5\%$ maximum, and the short circuit current is approx. $500\ \mu\text{A} \pm 5\%$ maximum.
(The internal circuit is pulled up to 5 V through 10 k Ω .)
 - When wiring over a great distance, use a small relay and extend the coil side of that relay.

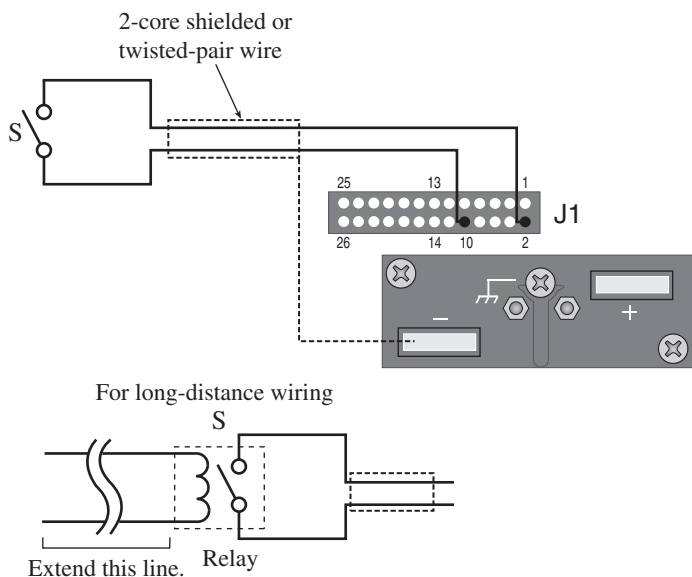

Fig.4-8 Shutdown control connection

4.2 Remote Monitoring

4.2.1 External Monitoring of the Output Voltage and Output Current

The J1 connector consists of monitor outputs for output voltage and output current.

Table 4-3 Monitor output of output voltage and output current

Pin No.	Signal Name	Description
1	A COM	Common for remote control input and output monitor
8	V MON	Monitor output of output voltage 0 to approx. 10 V for 0 to rated output voltage
9	I MON	Monitor output of output current 0 to approx. 10 V for 0 to rated output current

⚠ WARNING • Shorting V MON and I MON to A COM can cause damage to the unit.

NOTE • Monitor output rating
Output impedance: 1 k Ω or less
Maximum output current: Approx. 10 mA

- The monitor outputs are used to monitor the DC voltage (mean value). They cannot be used to accurately monitor the AC components (ripple, transient response, etc.) of the actual output voltage or current.

4.2.2 External Monitoring of the Operation Mode

The J1 connector consists of status outputs that can be used to externally monitor the operating condition of the unit. The status outputs consist of the following five items.

The outputs are open collector outputs of photocouplers; they are insulated from the internal circuits of the unit.

Table 4-4 Status output

Pin No.	Signal Name	Description	Circuit
17	STATUS COM	Common for status output Photocoupler emitter output	
18	CV STATUS	Set to low level when in constant voltage mode. Photocoupler collector output	
19	CC STATUS	Set to low level when in constant current mode. Photocoupler collector output	
20	ALM STATUS	Set to low level when a protection function is activated. Photocoupler collector output	
21	OUTON STATUS	Set to low level when OUTPUT is turned off. Photocoupler collector output	
22	PWR OFF STATUS	Output a low level signal for approximately 0.5 s when the POWER switch turned off. Photocoupler collector output	

NOTE

- Maximum rating of each signal terminal
Maximum applied voltage (to a single pin) of 30 V and maximum current of 8 mA

4.3 Digital Remote Control

In addition to operating the PAS from the front panel, you can use a power supply controller (PIA4830/PIA4850/PIA4810) to remotely control the PAS via the USB, GPIB or RS232C interface.

NOTE • Version 2.10 or later is required for the PIA4800 series. If you are using an earlier version, you need to upgrade. For details, contact your Kikusui agent/distributor.

You can confirm a version of the PIA4800 series through the IDN?.

4.3.1 Connecting of the Power Supply Controller and Device messages

The PAS and power supply controller are connected via a TP-BUS. Up to 32 devices can be connected to the TP-BUS.

To digital remotely control the unit, You must set CV control and CC control of CONFIG settings to “0” (panel control).

For details on CONFIG Setting, See "3.2.4 Unit Configuration (CONFIG)"

For connection to a Power Supply Controller and device messages, refer to the “Connecting & Programming Guide” [index.html] in the CD-ROM that came with the PIA4800 series.

The “Connecting & Programming Guide” is HTML format. Microsoft Internet Explorer or Google Chrome is required to view the HTML files.

The list of messages and connection of power supply of Connecting & Programming guide is provided in a PDF file. Adobe Reader is required to view the PDF files.

The latest version of the “Connecting & Programming Guide” can be downloaded from Web site (<http://www.kikusui.co.jp/en/download/>).

This page has been intentionally left blank.

Chapter. 5 Parallel and Series Operation

The output voltage can be increased by connecting PAS series power supplies with the same output rating in series and operating them in master-slave series mode. Additionally, the output current can be increased by connecting PAS series power supplies with the same output rating in parallel and operating them in master-slave parallel mode.

In a master-slave system, one of the connected units is made a master and all others slaves. The master is used to control the all the connected power supply units.

The maximum number of connectable units including master and slave devices varies depending on the model as follows.

Table 5-1 The maximum number of connectable units

	Series mode	Parallel mode
350W type	2 units	5 units
700W type	2 units	3 units
1000W type	2 units	2 units

⚠ WARNING • Master-slave series operation is not possible on the 320 V and 500 V models. If connected in series, the output voltage will exceed the isolation voltage creating a dangerous condition.

NOTE • During series/parallel operation, the accuracy of master and slave units is the same as that of single units. However the error in preset values between master and slave units is within approx. 3 %.

5.1 Master-Slave Series Operation

⚠ WARNING • Master-slave series operation is not possible on the 320 V and 500 V models. If connected in series, the output voltage will exceed the isolation voltage creating a dangerous condition.

5.1.1 Functions during Master-Slave Series Operation

The functions of the unit during master-slave series operation are described below.

Voltage display and current display

As shown in Fig.5-1, the current is displayed only on the master unit, and the voltage is displayed on each unit. For the total output voltage, sum the voltages of the master and slave units.



Fig.5-1 Panel display during series operation

NOTE • The power display can be switched only on the master unit. However, the power of the entire system cannot be displayed.

Remote sensing

Remote sensing function cannot be used during master-slave series operation.

Analog remote control

Analog remote control can be performed only against the master unit.

For details on the analog remote control, see "4.1 Analog Remote Control".

For details, see "4.1 Analog Remote Control".

Remote monitoring

External monitoring of output voltage (V MON)

The output voltage of each master and slave unit can be monitored.

For the total output voltage, sum the monitor values of the master and slave units.

External monitoring of output current (I MON)

The output current can be monitored only on the master unit.

Status monitors

Status of the constant voltage operation (CV STATUS), constant current operation (CC STATUS), OUTPUT ON, and POWER switch ON can be monitored on each master and slave unit.

For details on ALM STATUS, see the next section, "Alarms"

For details on the remote monitoring, see "4.2 Remote Monitoring".

Alarms

Below is the operation of the units when alarms are activated through OVP (overvoltage protection), OCP (overcurrent protection), and OHP (overheat protection).

Slave unit

An alarm is activated independently, and OUTPUT or POWER switch is turned off.

Master unit

By connecting ALM STATUS of the master unit and SHUT DOWN of the slave units as shown in Fig.5-2, the OUTPUT or POWER switch of the entire system can be turned off when an alarm on the master unit is activated.

5.1.2 J1 Connector Connection (Series Operation)

For master-slave series operation, two units are connected as shown in Fig.5-2.

The maximum output voltage during master-slave series operation is twice the rated output voltage of a single unit.

Connecting the signal wires (series operation)

The connector needed to connect the J1 connector is not provided. For detail, see "4.1.1 About the J1 Connector" .



- The J1 connector contains pins that are at the same electric potential as the output terminal. If you are not using the J1 connector, to prevent the possibility of electric shock, be sure to insert the protective socket provided.
- To prevent the possibility of electric shock, be sure to use the protective cover on the sockets.

Connection procedure

1. Decide the power supply that is to be the master unit.
2. Connect the J1 connectors on the rear panel as shown in Fig.5-2.

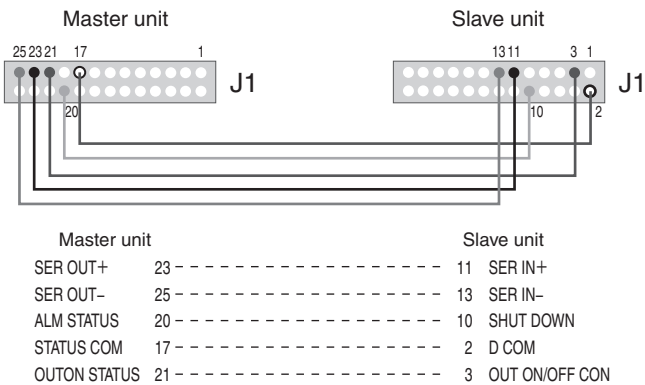

Fig.5-2 Connection for series operation

5.1.3 Load Connection for Series Operation

-
- ⚠ WARNING** • When you are done with the connection, be sure to attach the output terminal cover to prevent the possibility of electric shock.
- Securely connect the protective conductor terminal of the unit.
- ⚠ CAUTION** • Take measures to securely connect the load cable to the terminals such as by using crimp terminals.
-

Connection procedure

1. Check that the POWER switch is off on all power supply units to be connected in series.
2. Remove the output terminal cover.
3. Connect the load cable and chassis cable as shown in Fig.5-3.

Connect one of either the - (neg.) terminal or the + (pos.) terminal of the master or slave unit to the chassis terminal.

Wire the load cables connecting the power supply units as thick and as short as possible. If the voltage drop in the output cable is large, the difference in potential between power supply units and load fluctuations becomes large.

Refer to "3.3 Connecting the Load" and select a load cable with sufficient current capacity.

4. Attach the output terminal cover.

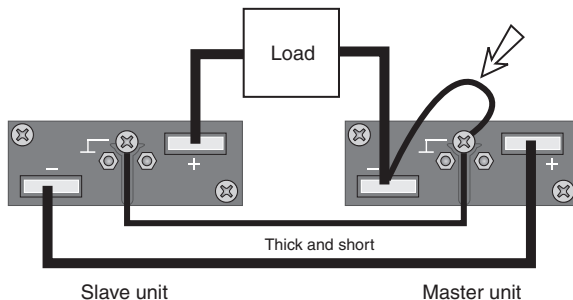

Fig.5-3 Load Connection for Series Operation
(Example in which the - (neg.) terminal of the master unit is connected to the chassis terminal)

5.1.4 Master-Slave Series Operation Setup

To perform master-slave series operation, the master and slave units as well as various protection functions must be set up.

Setting the master and slave units

Set the master and slave units through CONFIG settings.

-
- NOTE** • Set the slave units through CONFIG settings after setting the OVP trip point.
-

For details on CONFIG settings, see "3.2.4 Unit Configuration (CONFIG)".

1. While pressing the CONFIG switch, turn on the POWER switch. After displaying the version, the CONFIG switch lights up (CONFIG setting mode).
2. Press the CURRENT switch to move to the left-most digit on the current display.
3. Use the dial to set as follows according to the roles of each power supply unit.

Master unit : 0
Slave unit : 2



Fig.5-4 Setup example of a slave unit for series operation

You can check the settings by pressing the CONFIG switch. The external remote control settings are forced to local when units are set to slave mode.

OVP (overvoltage protection) setting

OVP (overvoltage protection) is set on both master and slave units according to "3.2.2 Setting the OVP (Overvoltage Protection) Trip Point".

OVP is set to 1/2 the voltage to be protected on each unit.

However, set the OVP trip point of the slave unit slightly higher than that of the master unit, so that the OVP function of the master unit is activated first. Set the trip point before specifying units to operate in slave mode through CONFIG settings.

OCP (overcurrent protection) setting

OCP (overcurrent protection) is set on both master and slave units according to "3.2.3 Setting the OCP (Overcurrent Protection) Trip Point".

Set the OCP trip point of the slave unit slightly higher than that of the master unit, so that the OCP function of the master unit is activated first.

5.1.5 Master-Slave Series Operation Procedure

NOTE

- When turning on the POWER switch, be sure to turn on the master unit first.
When turning off the POWER switch, be sure to turn on the slave units first.
 - If you don't keep the procedure, erroneous operation may result.
-

The switches on the slave units are disabled. OUTPUT on/off operation is performed on the master unit.

When you are done with the steps described in "5.1.4 Master-Slave Series Operation Setup" normal operations are performed on the master unit.

5.2 Master-Slave Parallel Operation

5.2.1 Functions during Master-Slave Parallel Operation

The functions of the unit during master-slave parallel operation are described below.

Voltage display and current display

As shown in Fig.5-5, the voltage is displayed only on the master unit, and the current is displayed on each unit. For the total output current, sum the currents of the master and slave units.



Fig.5-5 Panel display during parallel operation

-
- NOTE** • The power display can be switched only on the master unit. However, the power of the entire system cannot be displayed.
-

Remote sensing

Remote sensing function can be used only on the master unit.
For details, see "3.6 Remote Sensing".

Analog remote control

Analog remote control can be performed only against the master unit.
For details, see "4.1 Analog Remote Control".

Remote monitoring

External monitoring of output voltage (V MON)

The output voltage can be monitored only on the master unit.

External monitoring of output current (I MON)

The output current of each master and slave unit can be monitored. For the total output current, sum the monitor values of the master and slave units.

Status monitors

Status of the constant voltage operation (CV STATUS), constant current operation (CC STATUS), OUTPUT ON, and POWER switch ON can be monitored on each master and slave unit. However, slave units always output the status of the constant current operation.

For details on ALM STATUS, see the next section, "Alarms".

For details on the remote monitoring, see "4.2 Remote Monitoring".

Alarms

Below is the operation of the units when alarms are activated through OVP (overvoltage protection), OCP (overcurrent protection), and OHP (overheat protection).

Slave unit

An alarm is activated independently, and OUTPUT or POWER switch is turned off.

Master unit

By connecting ALM STATUS of the master unit and SHUT DOWN of the slave units as shown in Fig.5-6, the OUTPUT or POWER switch of the entire system can be turned off when an alarm on the master unit is activated.

5.2.2 J1 Connector Connection (Parallel Operation)

For master-slave parallel operation, two units are connected as shown in Fig.5-6.

The maximum output current during master-slave parallel operation is equal to the number of units connected in parallel multiplied by the rated output current of a single unit.

Connecting the signal wires (parallel operation)

The connector needed to connect the J1 connector is not provided. For detail, see "4.1.1 About the J1 Connector" .



- The J1 connector contains pins that are at the same electric potential as the output terminal. If you are not using the J1 connector, to prevent the possibility of electric shock, be sure to insert the protective socket provided.
 - To prevent the possibility of electric shock, be sure to use the protective cover on the sockets.
-

Connection procedure

1. Decide the power supply that is to be the master unit.
2. Connect the J1 connectors on the rear panel as shown in Fig.5-6.

When connecting more than two slave units, repeat the steps for connecting slave units 1 and 2.

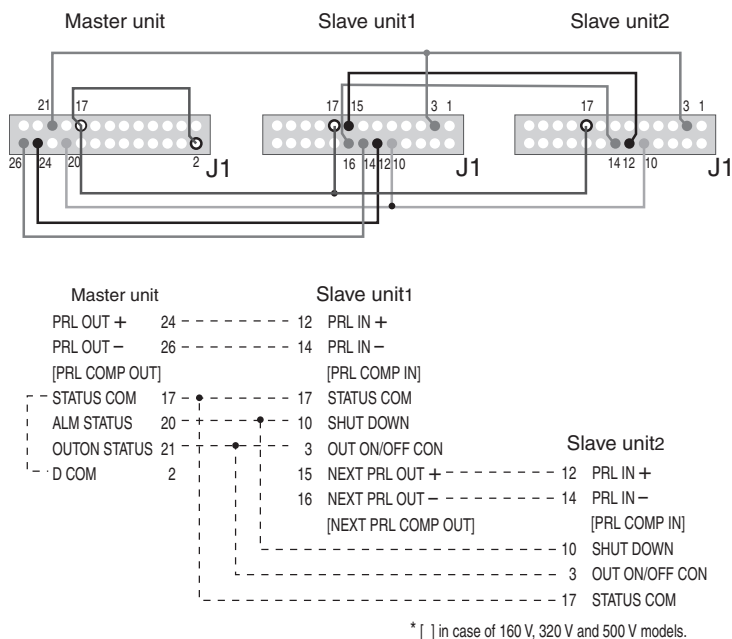

Fig.5-6 Connection for parallel operation

5.2.3 Load Connection for Parallel Operation

-
- ⚠ WARNING** • When you are done with the connection, be sure to attach the output terminal cover to prevent the possibility of electric shock.
- ⚠ CAUTION** • When connecting the output terminal to the chassis terminal, be sure that the output terminal of the same polarity (+ or -) for each unit is connected to the chassis terminal. If you connect the output terminal of different polarities for each unit, the output is short-circuited through the GND cable of the AC power cord. This will result in failure to obtain proper outputs and will burn the cable connected to the chassis.
- Take measures to securely connect the load cable to the terminals such as by using crimp terminals.
-

Connection procedure

1. Check that the POWER switch is off on all power supply units to be connected in parallel.
2. Remove the output terminal cover.
3. Connect the cables as shown in Fig.5-7.

Refer to "3.3 Connecting the Load" and select a load cable with sufficient current capacity. In addition, use the shortest load cables of the same length and cross-sectional area from each power supply to the load.

Wire the signal cable of the J1 connector and load cables as far apart as possible.

4. Attach the output terminal cover.

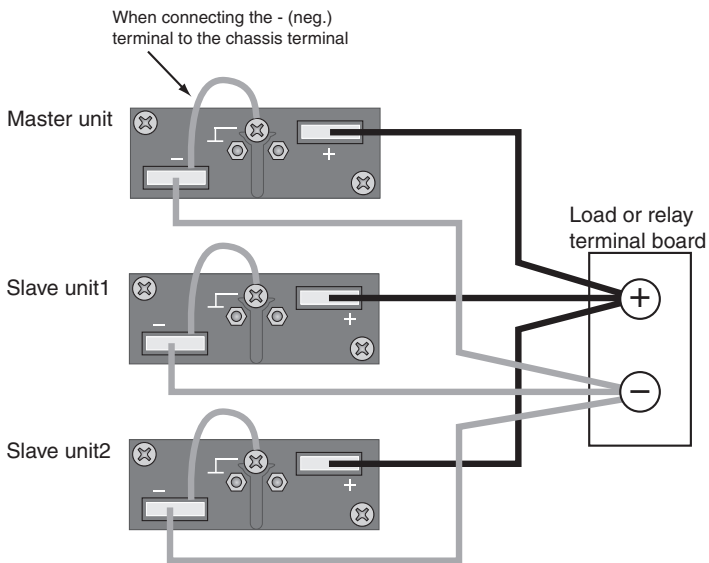

Fig.5-7 Load Connection for Parallel Operation

5.2.4 Master-Slave Parallel Operation Setup

To perform master-slave parallel operation, the master and slave units as well as various protection functions must be set up.

Setting the master and slave units

Set up the master and slave units through CONFIG settings.

NOTE • Set the slave units through CONFIG settings after setting the OVP trip point.

For details on CONFIG settings, see "3.2.4 Unit Configuration (CONFIG)".

1. While pressing the CONFIG switch, turn on the POWER switch. After displaying the version, the CONFIG switch lights up (CONFIG setting mode).
2. Press the CURRENT switch to move to the left-most digit on the current display.
3. Use the dial to set as follows according to the roles of each power supply unit.

Master unit : 0

Slave unit : 1

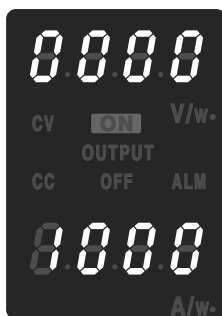

Fig.5-8 Setup example of a slave unit for parallel operation

You can check the settings by pressing the CONFIG switch. The external remote control settings are forced to local when units are set to slave mode.

OVP (overvoltage protection) setting

OVP (overvoltage protection) is set on both master and slave units according to "3.2.2 Setting the OVP (Overvoltage Protection) Trip Point".

However, set the OVP trip point of the slave unit slightly higher than that of the master unit, so that the OVP function of the master unit is activated first. Set the trip point before specifying units to operate in slave mode through CONFIG settings.

OCP (overcurrent protection) setting

OCP (overcurrent protection) is set on both master and slave units according to "3.2.3 Setting the OCP (Overcurrent Protection) Trip Point".

Set the value equal to the current to be protected divided by the number of units connected in parallel for OCP.

Set the OCP trip point of the slave unit slightly higher than that of the master unit, so that the OCP function of the master unit is activated first.

5.2.5 Master-slave parallel Operation Procedure

NOTE

- When turning on the POWER switch, be sure to turn on the master unit first.

When turning off the POWER switch, be sure to turn on the slave units first. If you don't keep the procedure, erroneous operation may result.

The switches on the slave units are disabled. OUTPUT on/off operation is performed on the master unit.

When you are done with the steps described in "5.2.4 Master-Slave Parallel Operation Setup" normal operations are performed on the master unit.

Chapter. 6 Names and Functions of Controls

This chapter describes the names and functions of switches, displays, connectors, and other parts of the front panel and rear panel.

6.1 Front Panel

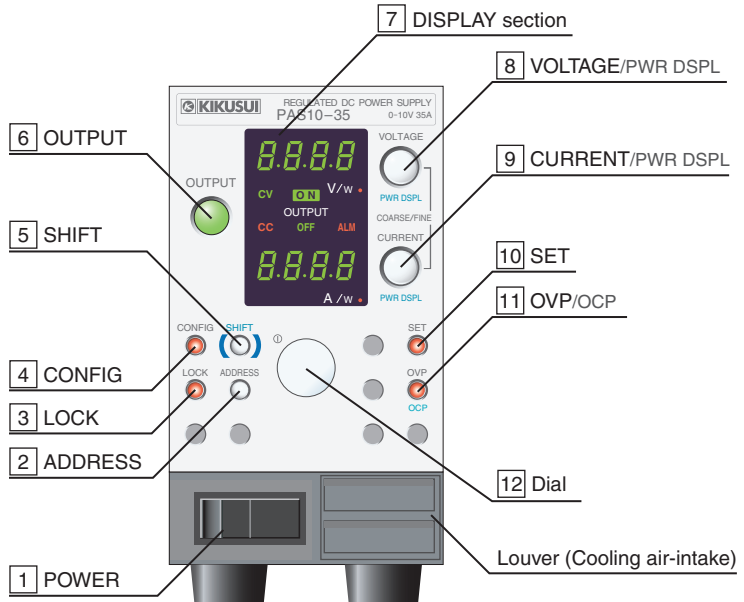

Fig.6-1 Front panel (Example:350W type)

[1] POWER

Power switch of the unit. Depress the switch to the (|) side to turn the power on, (○) side to turn it off.

[2] ADDRESS

Sets the unit's address in the range of 05 to 36 for digital remotely controlling the unit. Press the switch to set the value; press it again to release. The specified address takes effect when the unit is power cycled. For details, see “Connecting & Programming Guide” in the CD-ROM that came with the PIA4800 series.

[3] LOCK

Switch used to disable all operations except turning on/off of the OUTPUT.

The switch lights while the unit is locked.

To release, press the switch again.

For details, see "3.5 LOCK Function".

[4] CONFIG

If turn on the POWER switch while pressing the CONFIG switch, you can set the various setting of operation of the unit (CONFIG setting mode). In addition, press the CONFIG switch when the unit is turned on, the CONFIG setting can be confirmed.

For details, see "3.2.4 Unit Configuration (CONFIG)".

[5] SHIFT

Pressing a switch with blue characters while pressing this switch activates the function indicated by the blue characters.

[6] OUTPUT

Switch used to turn on/off the output. The on/off status can be confirmed on the display when the unit is turned on.

Normally, the unit powers up with the OUTPUT turned off when the POWER switch is turned on. You can set the unit so that it powers up with the OUTPUT turned on. For details, see "3.2.4 Unit Configuration (CONFIG)".

[7] DISPLAY section

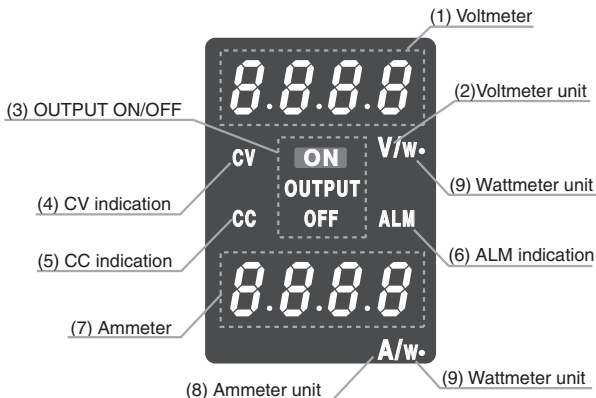

Fig.6-2 Display section

- 1) Voltmeter
Indicates the preset output voltage during setup mode when the SET switch is illuminated. Indicates the output voltage when the SET switch is not illuminated. Indicates the OVP trip point when the OVP switch is illuminated.
Indicates the power when the unit is switched to power display.
- 2) Voltmeter unit
Indicates the unit V of the displayed voltage value.
- 3) OUTPUT ON/OFF
Indicates the ON/OFF status of OUTPUT.
- 4) CV indication
Illuminates when the unit is operating in the constant voltage mode.
- 5) CC indication
Illuminates when the unit is operating in the constant current mode.
- 6) ALM indication
Illuminates when any of the protection circuits, OVP, OCP, OHP, or SHUT, is activated.
- 7) Ammeter
Indicates the preset output current during setup mode when the SET switch is illuminated. Indicates the output current when the SET switch is not illuminated. Indicates the OCP trip point if you press the OCP switch while pressing the SHIFT switch.
Indicates the power when the unit is switched to power display.
- 8) Ammeter unit
Indicates the unit A of the displayed current value.
The unit displayed on the panel is mA on the 500 V model.
- 9) Wattmeter unit
Indicates the unit W of the displayed power value.
For details on the power display, see "3.4 Switching the Power Display".

[8] VOLTAGE/PWR DSPL

Selects the digit when setting the voltage. The digit changes for each click.

Pressing the VOLTAGE switch while pressing the SHIFT switch displays the output power on the voltage display. See "3.4 Switching the Power Display".

[9] CURRENT/PWR DSPL

Selects the digit when setting the current. The digit changes for each click.

Pressing the CURRENT switch while pressing the SHIFT switch displays the output power on the current display. See "3.4 Switching the Power Display".

[10] SET

Switch used to set or check the output voltage value or output current value. When the switch is illuminated, the value can be entered. The value is indicated on the display.

When the switch is not illuminated, the display section shows the measured values of the voltage and current of the output terminals.

[11] OVP/OCP

Pressing this switch displays the OVP (overvoltage protection) trip voltage on the display section.

For details on how to set the OVP trip point, see "3.2.2 Setting the OVP (Overvoltage Protection) Trip Point".

Pressing the OVP switch while pressing the SHIFT switch illuminates the switch and displays the OCP (overvoltage protection) trip current on the display section.

For details on how to set the OCP trip point, see "3.2.3 Setting the OCP (Overcurrent Protection) Trip Point".

[12] Dial

Turn the dial (clockwise or counterclockwise) to set the voltage or current, CONFIG settings, and node address.

You can also press when set the voltage or current, the dial to change the digit.

6.2 Rear Panel

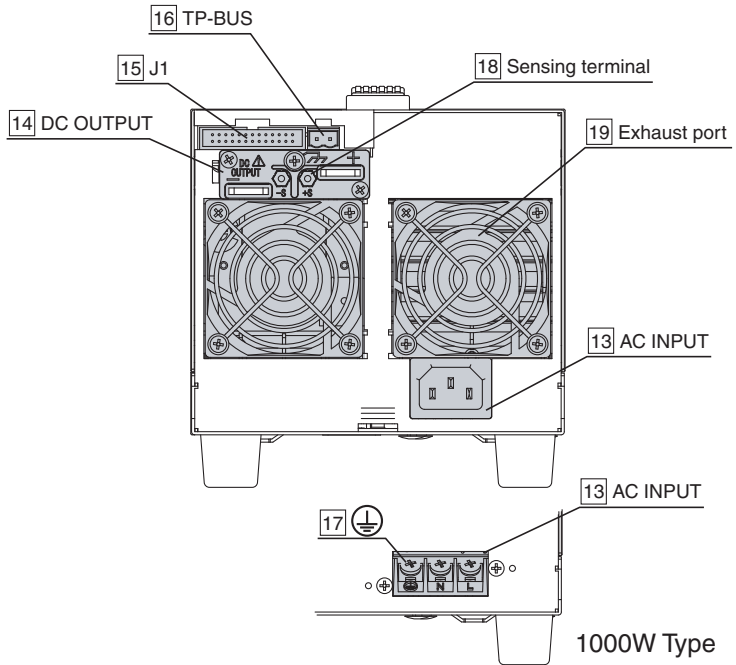

Fig.6-3 Rear panel

[13] AC INPUT ⚠

AC power cord connector (350W and 700W types) or terminal board (1000W type) used to supply power to the unit.

⚠ WARNING

• Improper handling can cause electric shock.

Be sure to follow the directions given in "1.3 Connecting the AC power cord".

• For your safety, be sure to ground the unit.

For details, see "1-4 Connection of the AC power cord on the unit side".

[14] DC OUTPUT

Output terminal.



- To prevent the possibility of electric shock, be sure to turn off the POWER switch when handling this terminal.
 - Be sure to attach the output terminal cover after wiring the load.
-

[15] J1

Connector for selecting analog remote control, parallel/series operation, and other functions. For details, see "4.1 Analog Remote Control" and "4.2 Remote Monitoring".

[16] TP-BUS

Connector used to connect to a Kikusui's PIA4800 Series Power Supply Controller using a twisted-pair cable when digital remotely controlling the unit.

For details, see "4.3 Digital Remote Control".

[17] (Protective conductor terminal)

Terminal used to ground the unit to an electrical ground (safety ground).



- To prevent the possibility of electric shock, be sure to turn off the POWER switch when handling this terminal.
-

[18] Sensing terminal

Terminal used to connect the sensing wires.

For details, see "3.6 Remote Sensing".

[19] Exhaust port

Exhaust port used to exhaust the internal heat using a fan motor.

Secure sufficient space around the exhaust port and the unit for adequate ventilation.

This chapter describes maintenance and inspection of the unit. Conduct periodic maintenance and inspection to maintain the initial performance as long as possible.

7.1 Cleaning

⚠ WARNING • When cleaning the unit, be sure to turn off the POWER switch and remove the AC power cord plug or turn off the switchboard.

7.1.1 Cleaning the Panels

If the panel needs cleaning, gently wipe using a soft cloth with water-diluted neutral detergent.

⚠ CAUTION • Do not use volatile solvents such as thinner or benzene. They may discolor the surface or erase the printed characters.

7.1.2 Cleaning the Dust Filter

A dust filter is installed on the inside of the louver on the front panel. Periodically clean the filter for prevent clogging.

⚠ CAUTION • Clogged filters hinder the cooling of the inside of the unit and can cause malfunction and shortening of the service life.

■ 350W type

Filter below the operation panel

1. As shown in Fig.7-1, pull the bottom section of the louver toward you and remove the louver from the panel.



Fig.7-1 Removing the louver

2. Remove the dust filter from the inside of the louver and clean it.

Remove the dust on the dust filter such as by using a vacuum cleaner. If the filter is extremely dirty, clean it using a water-diluted neutral detergent and dry it completely.

⚠ CAUTION • When the unit is in operation, air is sucked through the dust filter to cool the unit. If moisture is included in the dust filter, the temperature or humidity inside the unit increases and may cause a malfunction.

3. Attach the dust filter to the louver.
Be sure the direction of the louver and dust filter is correct.



Fig.7-2 Attaching the dust filter

4. Bend the filter and hold it with your fingers. Then, attach the louver to the panel.



Fig.7-3 Attaching the Louver

5. Press the filter to the back side of the panel with your finger so that the entire section below the panel is covered.



Fig.7-4 Setting the filter

■ 700W and 1000W types

Filter below the operation panel

1. As shown in Fig.7-5, pull the bottom section of the louver toward you and remove the louver from the panel.



Fig.7-5 Removing the louver

2. Remove the dust filter from the inside of the louver and clean it.

Remove the dust on the dust filter such as by using a vacuum cleaner. If the filter is extremely dirty, clean it using a water-diluted neutral detergent and dry it completely.

⚠ CAUTION • When the unit is in operation, air is sucked through the dust filter to cool the unit. If moisture is included in the dust filter, the temperature or humidity inside the unit increases and may cause a malfunction.

3. Attach the dust filter to the louver.

Be sure the direction of the louver and dust filter is correct.



Fig.7-6 Attaching the dust filter

4. Bend the filter and hold it with your fingers. Then, attach the louver to the panel. At this point, align the hook on the right side of the louver to the inside the panel as shown in Fig.7-7.



Fig.7-7 Attaching the Louver

5. Attach the louver to the panel by pressing from the front.

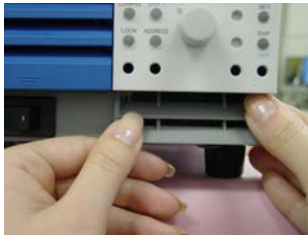

Fig.7-8 Setting the filter

6. Press the filter to the back side of the panel with your finger so that the entire section below the panel is covered.



Fig.7-9 Setting the filter

Filter on the side of the operation panel

1. As shown in Fig.7-10, pull down the top section of the louver while pulling the bottom step toward you.



Fig.7-10 Removing the louver

2. Remove the dust filter from the inside of the louver and clean it.

Remove the dust on the dust filter such as by using a vacuum cleaner. If the filter is extremely dirty, clean it using a water-diluted neutral detergent and dry it completely.

CAUTION • When the unit is in operation, air is sucked through the dust filter to cool the unit. If moisture is included in the dust filter, the temperature or humidity inside the unit increases and may cause a malfunction.

3. Attach the dust filter to the louver.

Attach it so that the dust filter fits inside the hooks of the louver.

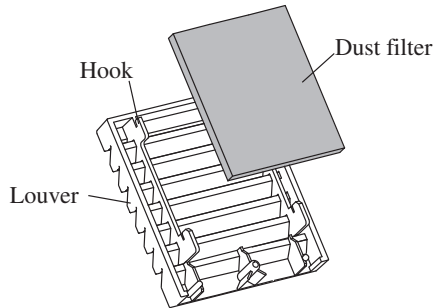

Fig.7-11 Attaching the dust filter

4. Align and set the hooks of the louver to the grooves. While pressing the fourth step from the bottom, slide the louver upward to attach it to the panel.



Fig.7-12 Attaching the Louver

7.2 Inspection

■ AC power cord

Check that the insulation coating is not broken and that the plug is not cracked or falling apart.

 **WARNING** • Breaks in the insulation coating may cause electric shock.
If a break is found, stop using the unit immediately.

To purchase accessories, contact your Kikusui agent/distributor.

7.3 Calibration

The unit is calibrated at the factory before shipment. However, periodic calibration is necessary due to changes that occur after extended use.

For calibration, contact your Kikusui agent/distributor. If you wish to calibrate the unit, follow the procedure below. The calibration procedure includes all calibration items of the unit.

7.3.1 Test Equipment Required

For calibration, the following equipment is necessary.

- DC voltmeter (DVM) with measuring accuracy of 0.02 % or better.
- Shunt resistor with accuracy of 0.1 % or better (a resistor capable of handling the rated output current of the PAS series power supply being calibrated).

Table 7-1 Recommended shunt resistor

Type		Shunt Resistor	
		Rating	Accuracy
350W Type	PAS10-35	50 A / 50 mV (1 mΩ)	0.1 % or better
	PAS20-18	20 A / 50 mV (2.5 mΩ)	
	PAS40-9	10 A / 50 mV (5 mΩ)	
	PAS60-6	10 A / 50 mV (5 mΩ)	
	PAS80-4.5	5 A / 50 mV (1 mΩ)	
	PAS160-2	5 A / 50 mV (10 mΩ)	
	PAS320-1	2 A / 50 mV (25 mΩ)	
	PAS500-0.6	1 A / 50 mV (50 mΩ)	
700W Type	PAS10-70	100 A / 50 mV (0.5 mΩ)	
	PAS20-36	50 A / 50 mV (1mΩ)	
	PAS40-18	20 A / 50 mV (2.5 mΩ)	
	PAS60-12	20 A / 50 mV (2.5 mΩ)	
	PAS80-9	10 A / 50 mV (5 mΩ)	
	PAS160-4	5 A / 50 mV (10 mΩ)	
	PAS320-2	5 A / 50 mV (10 mΩ)	
	PAS500-1.2	2 A / 50 mV (25 mΩ)	
1000W Type	PAS10-105	200 A / 50 mV (0.25 mΩ)	
	PAS20-54	100 A / 50 mV (0.5 mΩ)	
	PAS40-27	50 A / 50 mV (1 mΩ)	
	PAS60-18	20 A / 50 mV (2.5 mΩ)	
	PAS80-13.5	20 A / 50 mV (2.5 mΩ)	
	PAS160-6	10 A / 50 mV (5 mΩ)	
	PAS320-3	5 A / 50 mV (10 mΩ)	
	PAS500-1.8	2 A / 50 mV (25 mΩ)	

7.3.2 Environment

Perform calibration under the following environment.

- Ambient temperature: 23 °C ± 5 °C
- Ambient humidity: 80 % RH or less

To minimize the calibration error due to initial drift, warm up (turn on) the unit for at least 30 minutes before calibration. In addition, warm up the DVM and shunt resistor for their appropriate time.

7.3.3 Calibration Mode

To calibrate the unit, the unit must be put into calibration mode.

Turning on the POWER switch while pressing the SET switch causes the unit to enter the calibration mode after displaying the version number. The display is shown below.

To exit the calibration mode, turn off the POWER switch.

NOTE • Keep pressing the SET switch until the current display shows "CAL."

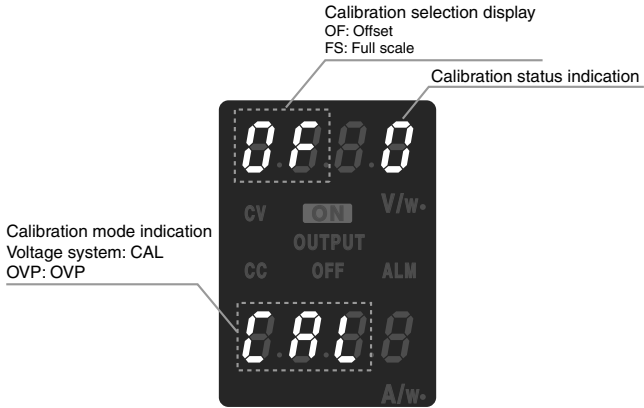

Fig.7-13Panel display of the voltage system calibration mode

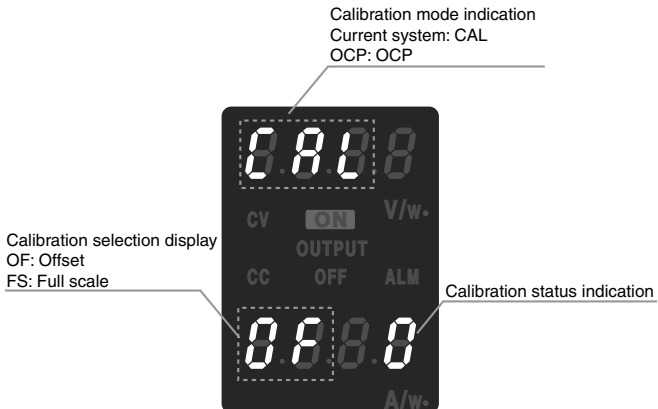

Fig.7-14Panel display of the current system calibration mode

■ Calibration status indication

The calibration status indication switches according to the calibration operation as follows:

- 0: Calibration start
- 1: Offset adjustment procedure complete
- 2: Full scale adjustment procedure complete
- 3: Offset and full scale procedure complete

7.3.4 Calibration Procedure

The following eight types of calibrated items are available.

- Output voltage offset
- Output voltage in full scale
- Output current offset
- Output current in full scale
- OVP in full scale
- OVP offset
- OCP in full scale
- OCP offset

Be sure to perform calibration on both the offset and full scale.

NOTE

- After calibrating the offset and full scale of the voltage and current, be sure to press the SET switch to exit the calibration. If you switch to a calibration of another item or turn off the POWER switch before pressing the SET switch, that calibration is invalid.
 - In the calibration mode, the unit outputs voltage or current used to calibrate the offset or full scale. The unit outputs approximately 10 % of the rated output during offset calibration and approximately the rated output during full scale calibration.
-

Voltage calibration procedure

■ Connecting the equipment

1. Turn off the POWER switch.
2. Connect a DVM to the output terminal.

Shown in Fig.7-15.

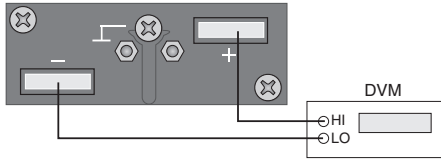

Fig.7-15 Connection for voltage system calibration

■ Warming up

3. Turn on the POWER switch while pressing the SET switch.
4. Check that the current display shows "CAL."
- If it is not, press the VOLTAGE switch.
5. Warm up the equipment including the DVM for sufficient time.

■ Output voltage offset and full scale

6. Press the VOLTAGE switch to display "OF 0" on the voltage display.
7. Turn on the OUTPUT.
Approximately 10 % of the rated output voltage is output.
8. Turn the dial so that the DVM reading is equal to 10 % of the rated output voltage.
Turning the dial while pressing the SHIFT switch increases the variable width.
9. Turn off the OUTPUT.
The voltage display shows "OF 1."
10. Press the VOLTAGE switch to display "FS 1" on the voltage display.
11. Turn on the OUTPUT.
Approximately 100 % of the rated output voltage is output.
12. Turn the dial so that the DVM reading is equal to the rated output voltage.
Turning the dial while pressing the SHIFT switch increases the variable width.

13. Turn off the OUTPUT.

The voltage display shows "FS 3."

14. Press the SET switch to store the calibration value.

The voltage display returns to "FS 0."

You are done calibrating the output voltage.

If you wish to exit from the output voltage calibration here, turn off the POWER switch.

OVP (overvoltage protection) calibration procedure

Be sure to complete the calibration of the voltage system before performing OVP calibration.

1. Turn off the POWER switch.
2. Connect a DVM to the output terminal.

Shown in Fig.7-15.

■ Warming up

3. Turn on the POWER switch while pressing the SET switch.
4. Check that the current display shows "CAL."
If it is not, press the VOLTAGE switch.
5. Warm up the equipment including the DVM for sufficient time.

■ OVP offset and full scale

6. Press the OVP switch to display "OVP" on the current display.
7. Press the VOLTAGE switch to display "OF 0" on the voltage display.
8. Turn on the OUTPUT.
Calibration starts automatically (ON blinks) and the POWER switch turns off. (This takes 30 s to 60 s.)
9. Turn on the POWER switch while pressing the SET switch.
10. Check that the current display shows "CAL."
If it is not, press the VOLTAGE switch.
11. Press the OVP switch to display "OVP" on the current display.
12. Press the VOLTAGE switch to display "FS 0" on the voltage display.
13. Turn on the OUTPUT.

Calibration starts automatically (ON blinks) and the POWER switch turns off. (This takes 30 s to 60 s.)

-
- NOTE**
- If you make a mistake in the calibration procedure or connection and the POWER switch immediately turns OFF when the OUTPUT is turned on by performing steps 8 through 13, the OVP calibration value may be off by a great extent. In such case, repeat steps 3 through 8 or 9 through 13 until the POWER switch turns off after 30 s to 60 s. (You may have to repeat the steps tens of times.)
-

You are done calibrating the OVP.

Current calibration procedure

■ Connecting the equipment

1. Turn off the POWER switch.
2. Connect a shunt resistor and a DVM to the output terminal.
Shown in Fig.7-16.

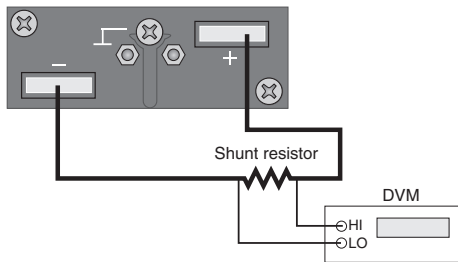

Fig.7-16 Connection for current system calibration

■ Warming up

3. Turn on the POWER switch while pressing the SET switch.
4. Check that the voltage display shows "CAL."
If it is not, press the CURRENT switch.
5. Warm up the equipment including the shunt resistor and DVM for sufficient time.

■ Output current offset and full scale

6. Press the CURRENT switch to display "OF 0" on the current display.
7. Turn on the OUTPUT.
Approximately 10 % of the rated output current is output.
8. Turn the dial so that the DVM reading is equal to 10 % of the rated output current.
Turning the dial while pressing the SHIFT switch increases the variable width.
9. Turn off the OUTPUT.
The current display shows "OF 1."
10. Press the CURRENT switch to display "FS 1" on the current display.
11. Turn on the OUTPUT.
Approximately 100 % of the rated output current is output.
12. Turn the dial so that the DVM reading is equal to the rated output current.
Turning the dial while pressing the SHIFT switch increases the variable width.
13. Turn off the OUTPUT.
The current display shows "FS 3."
14. Press the SET switch to store the calibration value.
The current display returns to "FS 0."

You are done calibrating the output current.

If you wish to exit from the output current calibration here, turn off the POWER switch.

OCP (overcurrent protection) calibration procedure

Be sure to complete the calibration of the current system before performing OCP calibration.

1. Turn off the POWER switch.
2. Connect a shunt resistor and a DVM to the output terminal.
Shown in Fig.7-16.

■ Warming up

3. Turn on the POWER switch while pressing the SET switch.
4. Check that the voltage display shows "CAL."
If it is not, press the CURRENT switch.
5. Warm up the equipment including the shunt resistor and DVM for sufficient time.

■ OCP offset and full scale

6. Press the OVP switch while pressing the SHIFT switch to display "OCP" on the voltage display.
7. Press the CURRENT switch to display "OF 0" on the current display.
8. Turn on the OUTPUT.
Calibration starts automatically (ON blinks) and the POWER switch turns off. (This takes 60 s to 90 s.)
9. Turn on the POWER switch while pressing the SET switch.
10. Check that the voltage display shows "CAL."
If it is not, press the CURRENT switch.
11. Press the OVP switch to display "OCP" on the current display.
12. Press the CURRENT switch to display "FS 0" on the current display.
13. Turn on the OUTPUT.
Calibration starts automatically (ON blinks) and the POWER switch turns off. (This takes 30 s to 60 s.)

You are done calibrating the OCP.

7.4 Malfunctions and Causes

This section describes remedies for malfunctions encountered during the use of the unit.

Six representative symptoms and their possible check items are indicated. Look for the item that corresponds to your case. In some cases, the problem can be solved quite easily.

If you find an item that corresponds to your case, follow the remedy for the item. If the remedy does not solve the problem or if your case does not match any of the items, contact your Kikusui agent/distributor.

Symptom1: The panel displays nothing.

Check Item	Cause and Remedy
<input type="checkbox"/> Wiring to the L, N, and GND of the AC IN terminal is wrong.	<ul style="list-style-type: none"> Connect the wires correctly by referring to "1.3 Connecting the AC power cord".
<input type="checkbox"/> The AC power cord is broken.	<ul style="list-style-type: none"> Replace the AC power cord with a new one.

Symptom2: "ALM" is illuminated when the OUTPUT switch is turned on.

Check Item	Cause and Remedy
<input type="checkbox"/> The OVP trip point is set to a voltage less than or equal to the output voltage.	<ul style="list-style-type: none"> The output overvoltage protection function has been activated. Set the OVP trip point to a voltage greater than or equal to the output voltage. See "3.2.2 Setting the OVP (Overvoltage Protection) Trip Point".
<input type="checkbox"/> The OCP trip point is set to a current less than or equal to the output current.	<ul style="list-style-type: none"> The output overcurrent protection function has been activated. Set the OCP trip point to a current greater than or equal to the output current. See "3.2.3 Setting the OCP (Overcurrent Protection) Trip Point".
<input type="checkbox"/> The actual output voltage is higher than the preset voltage on the panel.	<ul style="list-style-type: none"> The output overvoltage protection function has been activated. Voltage is being applied externally such as by a battery, or the unit may have malfunctioned.
<input type="checkbox"/> Remote sensing function is turned on.	<ul style="list-style-type: none"> The output overvoltage protection function may be activated. If you are not using the remote sensing function, turn off remote sensing in CONFIG. See "3.2.4 Unit Configuration (CONFIG)".

Check Item	Cause and Remedy
<input type="checkbox"/> A special load is connected.	<ul style="list-style-type: none"> The output overvoltage protection function may be activated. See "2.2 Load".
<input type="checkbox"/> The control cable for analog remote control is disconnected.	<ul style="list-style-type: none"> The output overvoltage protection function has been activated. Connect the cable correctly by referring to "4.1 Analog Remote Control".
<input type="checkbox"/> The external voltage is an overvoltage for analog remote control.	<ul style="list-style-type: none"> The output overvoltage protection function has been activated. Connect the cable correctly by referring to "4.1 Analog Remote Control".
<input type="checkbox"/> The internal temperature is abnormally high.	<ul style="list-style-type: none"> The overheat protection function has been activated. The ambient temperature may exceed the operating ambient temperature, the inlet or exhaust port may be blocked, the dust filter may be clogged, or the fan may have malfunctioned. If there is no problem in the operating environment and the alarm is activated, immediately stop the use of the instrument and request for repairs.
<input type="checkbox"/> Load cable is long while using remote sensing function.	<ul style="list-style-type: none"> The polarity of the remote sensing cable may be reversed, or the ends may be shorted. The load cable may also be too thin or too long. Set up the environment so that the voltage drop in the load cable is within the compensation voltage range (0.6 V for a single line). See "3.3.1 Load Cable" and "3.6 Remote Sensing"

Symptom3: No output is generated when the OUTPUT switch is turned on.

Check Item	Cause and Remedy
<input type="checkbox"/> Both "CV" and "CC" indications are off.	<ul style="list-style-type: none"> The VOLTAGE and CURRENT is set to 0 V and 0 A, respectively. Both LEDs may not light up depending on the internal offset adjustment. This is not a malfunction. Set the VOLTAGE and CURRENT to the required output using the dial.
<input type="checkbox"/> VOLTAGE or CURRENT is set to 0.	<ul style="list-style-type: none"> Set the VOLTAGE and CURRENT to the required output using the dial.
<input type="checkbox"/> The OUTPUT ON indication is off (OFF is illuminated).	<ul style="list-style-type: none"> See "4.1.6 Controlling the Output ON/OFF Using External Contact".
<input type="checkbox"/> The OUTPUT ON indication is on.	<ul style="list-style-type: none"> CV control setting or CC control setting in the CONFIG settings may be "1" (external control). Set it to "0" (panel control). See "3.2.4 Unit Configuration (CONFIG)"

Symptom4: The output is unstable.

Check Item	Cause and Remedy
<input type="checkbox"/> The operation mode switches from CV to CC or CC to CV.	<ul style="list-style-type: none"> Change the setting (VOLTAGE or CURRENT) that is limiting the output to a value greater than the current setting. If the preset value is at maximum, you must use a power supply with a larger output voltage or current. See "2.3 CV Power Supply and CC Power Supply".
<input type="checkbox"/> Parallel operation or series operation is enabled.	<ul style="list-style-type: none"> The performance when master-slave parallel operation or master-slave series operation is enabled is slightly lower than when the unit is operating as a standalone.
<input type="checkbox"/> Remote sensing in CONFIG is turned on.	<ul style="list-style-type: none"> If you are not using the remote sensing function, turn off remote sensing in CONFIG.
<input type="checkbox"/> 30 minutes has not elapsed since the power was turned on.	<ul style="list-style-type: none"> The output is unstable due to initial drift. Warm up (power turned on) the unit for at least 30 minutes.
<input type="checkbox"/> Both "CV" and "CC" indications are on.	<ul style="list-style-type: none"> If the output is oscillating when using remote sensing, insert a capacitor across the load. The internal circuitry may have malfunctioned. Immediately stop the use of the instrument and request for repairs.
<input type="checkbox"/> The ammeter indication is greater than the display error even without a load connected.	<ul style="list-style-type: none"> The internal circuitry may have malfunctioned.
<input type="checkbox"/> Output is generated even when the OUTPUT switch is turned off.	<ul style="list-style-type: none"> The internal circuitry may have malfunctioned.

Symptom5: The output ripple is large.

Check Item	Cause and Remedy
<input type="checkbox"/> The input voltage is outside the range.	<ul style="list-style-type: none"> Supply a voltage that is within the input voltage range.
<input type="checkbox"/> A source of strong magnetic or electrical field is nearby.	<ul style="list-style-type: none"> Being subjected to electromagnetic induction. Take measures such as moving the unit away from such generating sources and using twisted cables.
<input type="checkbox"/> External voltage noise is large during analog remote control.	<ul style="list-style-type: none"> Take measures against noise by referring to "4.1 Analog Remote Control".
<input type="checkbox"/> Remote sensing in CONFIG is turned on.	<ul style="list-style-type: none"> If you are not using the remote sensing function, turn off remote sensing in CONFIG.

Symptom6: The preset value does not match the output or the output does not match the indicated value.

Check Item	Cause and Remedy
<input type="checkbox"/> Remote sensing in CONFIG is turned on.	<ul style="list-style-type: none"> If you are not using the remote sensing function, turn off remote sensing in CONFIG.
<input type="checkbox"/> When using remote sensing, the sensing wires or load wires have poor contact or are broken.	<ul style="list-style-type: none"> Turn off the POWER switch and check the wiring.
<input type="checkbox"/> The load current has peaks or is pulse-shaped.	<ul style="list-style-type: none"> See "2.2 Load".

This chapter contains the specifications of the unit.

Unless otherwise specified, the specifications are based on the following conditions.

- The load is a pure resistance.
- After a warm-up of 30 minutes with current flowing through the load.

Common Specifications

Common Specifications			Notes
Input Specifications			
Input voltage *1		100 VAC to 240 VAC (85 VAC to 250 VAC)	100 VAC/ 200 VAC systems Operable without switching
Frequency *2		50 Hz to 60 Hz (47 Hz to 63 Hz)	—
Number of phase		Single phase	—
Hold-up time for power interruption		10 ms or more (at 50 % load), 5 ms or more (at rated load)	—
Protection Function			
OVP (Overvoltage protection)	Protection action *3	Turns off the OUTPUT or POWER switch. Turns on the ALM LED. *8	Indicates OVP in the voltmeter. *8
	Preset range	10 % to 110 % of the rated output voltage	—
	Setting error	± (Rated output voltage x 1.5 %)	—
OCP (Overcurrent protection)	Protection action *3, *4	Turns off the OUTPUT or POWER switch. Turns on the ALM LED. *8	Indicates OCP in the voltmeter. *8
	Preset range	10 % to 110 % of the rated output current	—
	Setting error	± (Rated output current x 3 %)	—
OHP (Overheat protection)	Protection action *5	Turns off OUTPUT. Turns on the ALM LED.	Indicates OHP in the voltmeter.
Display Function			
Voltage display	Maximum display	99.99 (models less than 100 V)/999.9 (100 V model or greater)	Fixed decimal point
	Display error *6	± (0.2 % of reading + 5 digits) at 23 °C ± 5 °C.	—
Current display	Maximum display	99.99 (models with rated 10 A or greater)/9.999 (models less than rated 10 A) 999.9 (models with rated 100 A or greater and PAS500 - 0.6) 9999 (PAS500 -1.2 and PAS500 -1.8)	Fixed decimal point The current display unit for the 500 V model is [mA].
	Display error *6	± (0.5 % of reading + 5 digits) at 23 °C ± 5 °C.	—

Common Specifications				Notes
Display Function (cont.)				
Power display (PWR DISP)		Displays the calculated output power in the voltmeter or ammeter. The W LED illuminates for the corresponding display section indicating the power.		Red LED
Operation display	OUTPUT on/off		ON: ON LED illuminates/ OFF: OFF LED illuminates	Green LED
	CV operation		CV LED illuminates	Green LED
	CC operation		CC LED illuminates	Red LED
	ALM operation *7, *8		ALM LED illuminates.	Red LED
Signal Output				
Monitor Signal output *9	VMON (Voltage)	At rated voltage output	10.00 V ± 0.25 V	—
		0 V At output	0.00 V ± 0.25 V	—
	IMON (Current)	At rated current output	10.00 V ± 0.25 V	—
		0 A At output	0.00 V ± 0.25 V	—

- *1. The value inside parentheses is the variable range. However, performance is guaranteed for fluctuation within ± 10 % of the nominal voltage. For the nominal voltage of 240 VAC, the upper limit of fluctuation is 250 VAC.
- *2. The value inside parentheses is the variable range.
- *3. The protection action OUTPUT off or POWER switch off is specified using BREAKER TRIP Enable/Disable in CONFIG.
The specified protection action is common to OVP and OCP. The protection action cannot be set separately for OVP and OCP.
The protection function recovers after correcting the abnormal condition and turning on the POWER switch.
- *4. Protection is not provided for the peak discharge current that is emitted from the built-in capacitor at the output end of the power supply unit caused by abrupt changes in the load.
- *5. The protection function recovers after correcting the abnormal condition and turning on the POWER switch.
- *6. ** % of reading denotes ** % of the readout value.
- *7. Illuminates when OVP (overvoltage protection), OCP (overcurrent protection), or OHP (overheat protection) is activated.
- *8. If protection action is set to POWER switch off (BREAKER TRIP of CONFIG set to Enable), the ALM LED illuminates for approximately 0.5 s. Other LEDs and displays are indefinite.
- *9. J1 connector on the rear panel. See the table 4-2 for the terminal arrangement.

Common Specifications			Notes
Signal output (cont.)			
Status signal output *1, *2	OUTON STATUS	Turns on when OUTPUT is turned on.	—
	CV STATUS	Turns on during CV operation.	—
	CC STATUS	Turns on during CC operation.	—
	ALM STATUS *3	Turns on when an alarm (OVP, OCP, OHP, or SHUT) is activated.	—
	PWROFF STATUS *4	Turns on for approximately 0.5 s after the POWER switch is turned off.	—
Control Function			
Digital control *5		TP BUS	Directly controllable from the PIA4810 or PIA4830.
External analog control *1	EXT-V CV CONT *6	0 % to 100 % of the rated output voltage in the range of 0 V to 10 V	CV external voltage control
	EXT-R CV CONT (1) *6	0 % to 100 % of the rated output voltage in the range of 0 kΩ to 10 kΩ	CV external resistance control Normal
	EXT-R CV CONT (2) *6	100 % to 0 % of the rated output voltage in the range of 0 kΩ to 10 kΩ	CV external resistance control Fail safe
	EXT-V CC CONT *6	0 % to 100 % of the rated output current in the range of 0 V to 10 V	CC external voltage control
	EXT-R CC CONT (1) *6	0 % to 100 % of the rated output current in the range of 0 kΩ to 10 kΩ	CC external resistance control Normal
	EXT-R CC CONT (2) *6	100 % to 0 % of the rated output current in the range of 0 kΩ to 10 kΩ	CC external resistance control Fail safe
	OUTPUT ON/OFF CONT	OUTPUT on at LOW level OUTPUT on at HIGH level	Select logic LOW/ HIGH using CONFIG
	SHUT DOWN *7	POWER switch off at LOW level	—
General			
Environment specifications	Operation ambient temperature	0 °C to + 50 °C (+32 °F to +122 °F)	—
	Operation ambient humidity	20 % to 85 % RH No condensation.	—
	Storage ambient temperature *8	-25 °C to + 70 °C (-13 °F to +158 °F)	—

Common Specifications				Notes
General (cont.)				
Environment specifications	Storage ambient humidity *8		90 % RH or less. No condensation.	—
Cooling system			Forced air cooling using a fan.	With thermal-sensing control (FAN control)
Grounding polarity			Negative grounding or positive grounding possible.	—
Isolation voltage			± 500 Vmax (excluding the 500 V model)/± 600 Vmax (500 V model)	—
Insulation specifications	With-standing voltage	Across the input terminals and chassis	No abnormalities at 1500 VAC for 1 minute.	—
		Across the input and output terminals	No abnormalities at 1500 VAC for 1 minute.	—
		Across the output terminals and chassis	No abnormalities at 500 VDC for 1 minute.	600 VDC for 1 minute for 160 V, 320 V, and 500 V models.
	Insulation resistance	Across the input terminals and chassis	500 VDC, 30 MΩ or more. At an ambient humidity of 70 % RH or less.	—
		Across the input and output terminals	500 VDC, 30 MΩ or more. At an ambient humidity of 70 % RH or less.	—
		Across the output terminals and chassis	500 VDC, 30 MΩ or more. At an ambient humidity of 70 % RH or less.	—

- *1. J1 connector on the rear panel. See the table 4-2 for the terminal arrangement.
- *2. Photocoupler open collector output. Maximum voltage 30 V, maximum current (sink) 8 mA. Insulated from the output and control circuits. Status signals are not mutually insulated.
- *3. If protection action is set to POWER switch off (BREAKER TRIP of CONFIG set to Enable), the output (on) is held for approximately 0.5 s.
- *4. Output when the POWER switch is turned off manually, shut down using external analog control, or turned off due to an ALM operation.
- *5. TP BUS connector on the rear panel.
- *6. The selection of (1) and (2) of EXT-V and EXT-R are made using CONFIG for both CV and CC. The selected function is enabled for each.
The input impedance EXT-V CV CONT and EXT-V CC CONT is approximately 30 kΩ.
The setting error is ± 5 % of the rated output voltage (EXT-V CV CONT, EXT-R CV CONT (1),(2)) and ± 5 % of the rated output current (EXT-V CC CONT, EXT-R CC CONT (1), (2)).
- *7. OUTPUT off when BREAKER TRIP of CONFIG is set to Disable.
- *8. Under packaged condition.

Common Specifications

General (cont.)

Accessories	Setup guide	1 pc.	
	Quick reference	Japanese: 1 pc., English: 1 pc.	
	Safety information	1 pc.	
	CD-ROM	1 pc	
	Power cord *1	350W and 700W types	SVT3 18AWG 3 P plug, with connector Cable length 2.5 m: 1 pc.
		1000W type	VCT3 3.5 mm2 plug, without connector Cable length 3 m: 1 pc. Cable clamp: 1 set Wire color: (black, white, green/yellow or green)
	Protection cover	Rear output terminal cover: 1 set Socket for analog control connector protection: 1 pc. (Attached to the J1 connector, with simple lock lever)	
	TP BUS connector	MSTB 2.5/2-ST-5.08: 1 pc.	
	Output terminal screw	M8 x 16: 2 sets (bolts, nuts, and spring washers) M4 x 8: 2 sets	
	Sensing terminal screw	M3 x 6: 2 sets (Attached to the sensing connector of the unit)	
Electromagnetic compatibility*2, *3		Complies with the requirements of the following directive and standards. EMC Directive 2014/30/EU EN 61326-1 (Class A*4) EN 55011 (Class A*4, Group 1*5) EN 61000-3-2 EN 61000-3-3 Applicable under the following conditions The maximum length of all cabling and wiring connected to the PAS must be less than 3 m.	
Safety*2		Complies with the requirements of the following directive and standard. Low Voltage Directive 2014/35/EU*3 EN 61010-1 (Class I*6, Pollution degree 2*7)	

*1. The power cord that comes standard with the unit is for a rated voltage of 125 VAC (250 VAC for the 1 000W type).

The power supply unit operates using a nominal supply voltage in the range of 100 VAC to 240 VAC without switching. However, if the 350W or 700W type is used under a supply voltage outside the 100 VAC to 120 VAC range, an appropriate rated power cord must be prepared.

The power cord included in the package may vary from the specifications due to the shipment destination.

*2. Does not apply to specially ordered or modified PASs.

*3. Limited to products that have the CE mark on their panels. Not be in compliance with EMC limits unless the ferrite core is attached on the cable for connection of J1 connector.

*4. This is a Class A equipment. The PAS is intended for use in an industrial environment. This product may cause interference if used in residential areas. Such use must be avoided unless the user takes special measures to reduce electromagnetic emissions to prevent interference to the reception of radio and television broadcasts.

- *5. This is a Group 1 equipment. The PAS does not generate and/or use intentionally radio-frequency energy, in the form of electromagnetic radiation, inductive and/or capacitive coupling, for the treatment of material or inspection/analysis purpose.
- *6. This is a Class 1 equipment. Be sure to ground the PAS's protective conductor terminal. The safety of this product is only guaranteed when the product is properly grounded.
- *7. Pollution is addition of foreign matter (solid, liquid or gaseous) that may produce a reduction of dielectric strength or surface resistivity. Pollution Degree 2 assumes that only non-conductive pollution will occur except for an occasional temporary conductivity caused by condensation.

350W Type Specifications

350W Type		PAS 10-35	PAS 20-18	PAS 40-9	PAS 60-6	PAS 80-4.5	
Output Specifications							
Power	Rated output power	350 W	360 W	360 W	360 W	360 W	
Voltage	Rated output voltage	10.00 V	20.00 V	40.00 V	60.00 V	80.00 V	
	Maximum preset voltage (typ) ^{*1}	105 % of rating					
	Accuracy of setting ^{*2}	0.1 % of rating + 10 mV ^{*3}					
	Source effect ^{*4}	0.05 % of rating + 3 mV ^{*3}					
	Load effect ^{*5}	0.05 % of rating + 5 mV ^{*3}					
	Transient response ^{*6}	1 ms					
	Ripple noise	(p-p) ^{*7}	60 mV				
		(RMS) ^{*8}	7 mV				
	Rise time (max) ^{*9}	150 ms (rated load)/ 150 ms (no load)					
	Fall time (max) ^{*10}	200 ms (rated load)/ 1500 ms (no load)					
	Temperature coefficient (max) ^{*11}	100 ppm/ °C (during analog remote control)					

350W Type (cont.)		PAS 160-2	PAS 320-1	PAS 500-0.6	—	—	
Output Specifications							
Power	Rated output power	320 W	320 W	300 W	—	—	
Voltage	Rated output voltage	160.0 V	320.0 V	500.0 V	—	—	
	Maximum preset voltage (typ) *1	105 % of rating			—	—	
	Accuracy of setting *2	0.1 % of rating + 10 mV *3			—	—	
	Power supply fluctuation *4	0.05 % of rating + 3 mV *3			—	—	
	Load fluctuation *5	0.05 % of rating + 5 mV *3			—	—	
	Transient response *6	2 ms			—	—	
	Ripple noise	(p-p) *7	60 mV	80 mV	120 mV	—	—
		(RMS) *8	10 mV	15 mV	20 mV	—	—
	Rise time (max) *9	250 ms (rated load)/ 150 ms (no load)					
	Fall time (max) *10	400 ms (rated load)/ 3000 ms (no load)					
Temperature coefficient (max) *11	100 ppm/ °C (during analog remote control)						

*1. The maximum preset voltage and maximum preset current are provided for establishing a constant voltage operation when the operation point is at [rated output voltage and rated output current]. It does not guarantee power supply to the load exceeding the rated output voltage.

To establish a constant voltage operation at the operation point [rated output voltage and rated output current], set the output current (I Set) so that rated output current < I Set ≤ maximum preset current.

Likewise, to establish constant current operation, set the output voltage (V Set) so that rate output voltage < V Set ≤ maximum preset voltage.

*2. The difference between the actual output voltage and the preset value under constant voltage operation.

*3. ** % of rating denotes ** % of the rated output voltage.

*4. Output voltage fluctuation with respect to ± 10 % fluctuation of the nominal input voltage (ex. 100 VAC) under constant voltage operation.

*5. Output voltage fluctuation when the output voltage is set to the rated output voltage and the load is changed from rated load to no load (open load) under constant voltage operation.

*6. The time it takes for the output voltage fluctuation to recover from outside 0.1 % + 10 mV of the output voltage setting to within 0.1 % + 10 mV when the output current is changed from 100 % to 50 % or 50 % to 100 % of the rating under constant voltage operation. The output voltage at 100 % output current is used as a reference.

*7. At a measurement frequency bandwidth of 10 Hz to 20 MHz.

*8. At a measurement frequency bandwidth of 5 Hz to 1 MHz.

*9. The time it takes for the output voltage to rise from 10 % to 90 % of the rating when the OUTPUT is turned on.

*10. The time it takes for the output voltage to fall from 90 % to 10 % of the rating when the OUTPUT is turned off. The time it takes for the output voltage to fall to 60 V or less is within 10 s when the POWER switch is turned off under OUTPUT on and no load condition.

*11. At an ambient temperature range of 0 °C to 50 °C.

350W Type		PAS 10-35	PAS 20-18	PAS 40-9	PAS 60-6	PAS 80-4.5
Output Specifications (cont.)						
Current	Rated output current	35.00 A	18.00 A	9.000 A	6.000 A	4.500 A
	Maximum preset current (typ) *1	105 % of rating				
	Accuracy of setting *2	0.5 % of rating + 20 mA *3				
	Source effect *4	0.1 % of rating + 10 mA *3				
	Load effect *5	0.1 % of rating + 10 mA *3				
	Ripple noise (RMS) *6	77 mA	40 mA	20 mA	13 mA	10 mA
	Temperature coefficient (max) *7	200 ppm/ °C (during analog remote control)				
Series/Parallel operation						
Master-slave parallel operation *8		Up to 5 units including the master unit (same models only)				
Master-slave series operation *9		Up to 2 units including the master unit (same models only)				
Input Specifications						
Current (max) *10		5.0 A (100 VAC)/ 2.5 A (200 VAC)				
Inrush current (max) *11		35 Apeak				
Power (max) *10		500 VA				
Power factor (typ) *12		0.980				
Efficiency (min) *13		70%				

- *1 The maximum preset voltage and maximum preset current are provided for establishing a constant current operation when the operation point is at [rated output voltage and rated output current]. It does not guarantee power supply to the load exceeding the rated output current.
To establish a constant voltage operation at the operation point [rated output voltage and rated output current], set the output current (I Set) so that rated output current < I Set ≤ maximum preset current.
Likewise, to establish constant current operation, set the output voltage (V Set) so that rated output voltage < V Set ≤ maximum preset voltage.
- *2 The difference between the actual output current and the preset value under constant current operation.
- *3 ** % of rating denotes ** % of the rated output current.
- *4 Output current fluctuation with respect to ± 10 % fluctuation of the nominal input voltage (ex. 100 VAC) under constant current operation.
- *5 Output current fluctuation when the output current is set to the rated output current and the load is changed from rated load to no load under constant current operation.

350W Type (cont.)		PAS 160-2	PAS 320-1	PAS 500-0.6	—	—
Output Specifications (cont.)						
Current	Rated output current	2.000 A	1.000 A	600.0 mA	—	—
	Maximum preset current (typ) *1	105 % of rating			—	—
	Accuracy of setting *2	0.5 % of rating + 5 mA *3			—	—
	Source effect *4	0.1 % of rating + 5 mA *3			—	—
	Load effect *5	0.1 % of rating + 5 mA *3			—	—
	Ripple noise (RMS) *6	5 mA			—	—
	Temperature coefficient (max) *7	200 ppm/ °C (during analog remote control)			—	—
Series/Parallel operation						
Master-slave parallel operation *8		Up to 5 units including the master unit (same models only)			—	—
Master-slave series operation *9		Up to 2 units including the master unit (same models only)	impossible		—	—
Input Specifications						
Current (max) *10		5.0 A (100 VAC)/ 2.5 A (200 VAC)				
Inrush current (max) *11		35 Apeak				
Power (max) *10		500 VA				
Power factor (typ) *12		0.980				
Efficiency (min) *13		70%				

*6 At a measurement frequency bandwidth of 5 Hz to 1 MHz.

*7 At an ambient temperature range of 0 °C to 50 °C.

*8 The difference in the output current between the master unit and the slave unit is within approximately 3 % of the rating.

*9 The difference in the output voltage between the master unit and the slave unit is within approximately 3 % of the rating.

*10 Under rated load.

*11 Excludes the charge current component that flows through the capacitor of the internal EMC filter circuit immediately after the POWER switch is turned on (within approximately 1 ms).

*12 Standard value at an input voltage of 100 VAC under rated load.

*13 At an input voltage of 100 VAC under rated load.

350W Type	PAS 10-35	PAS 20-18	PAS 40-9	PAS 60-6	PAS 80-4.5
General					
Weight *1	Approx. 3 kg (6.61 lbs)				
Dimensions	See outline drawing				

350W Type (cont.)	PAS 160-2	PAS 320-1	PAS 500-0.6	—	—
General					
Weight *1	Approx. 3 kg (6.61 lbs)			—	—
Dimensions	See outline drawing			—	—

*1. Unit only. Does not include accessories.

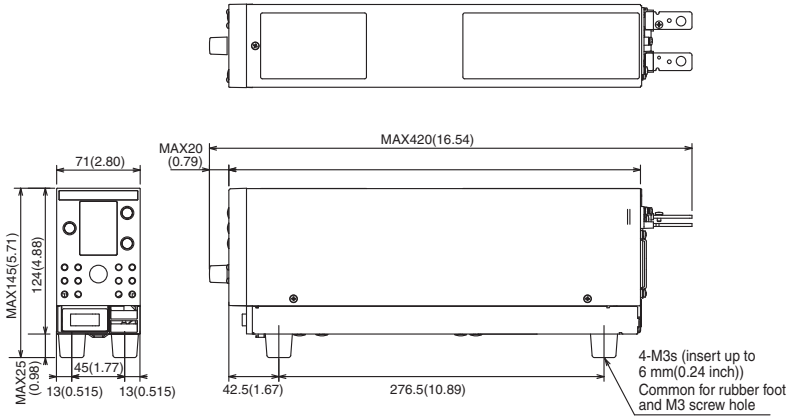

Unit: mm (inch)

Fig.8-1 350W type Outline Drawing

This page has been intentionally left blank.

700W Type Specifications

700W Type		PAS 10-70	PAS 20-36	PAS 40-18	PAS 60-12	PAS 80-9	
Output Specifications							
Power	Rated output power	700 W	720 W	720 W	720 W	720 W	
Voltage	Rated output voltage	10.00 V	20.00 V	40.00 V	60.00 V	80.00 V	
	Maximum preset voltage (typ) ^{*1}	105 % of rating					
	Accuracy of setting ^{*2}	0.1 % of rating + 10 mV ^{*3}					
	Source effect ^{*4}	0.05 % of rating + 3 mV ^{*3}					
	Load effect ^{*5}	0.05 % of rating + 5 mV ^{*3}					
	Transient response ^{*6}	1 ms					
	Ripple noise	(p-p) ^{*7}	80 mV				
		(RMS) ^{*8}	11 mV				
	Rise time (max) ^{*9}	150 ms (rated load)/ 150 ms (no load)					
	Fall time (max) ^{*10}	200 ms (rated load)/ 1500 ms (no load)					
	Temperature coefficient (max) ^{*11}	100 ppm/ °C (during analog remote control)					

700W Type (cont.)		PAS 160-4	PAS 320-2	PAS 500-1.2	—	—	
Output Specifications							
Power	Rated output power	640 W	640 W	600 W	—	—	
Voltage	Rated output voltage	160.0 V	320.0 V	500.0 V	—	—	
	Maximum preset voltage (typ) *1	105 % of rating			—	—	
	Accuracy of setting *2	0.1 % of rating + 10 mV *3			—	—	
	Power supply fluctuation *4	0.05 % of rating + 3 mV *3			—	—	
	Load fluctuation *5	0.05 % of rating + 5 mV *3			—	—	
	Transient response *6	2 ms			—	—	
	Ripple noise	(p-p) *7	80 mV	120 mV	170 mV	—	—
		(RMS) *8	15 mV	20 mV	30 mV	—	—
		Rise time (max) *9	250 ms (rated load)/ 150 ms (no load)				
		Fall time (max) *10	400 ms (rated load)/ 3000 ms (no load)				
		Temperature coefficient (max) *11	100 ppm/ °C (during analog remote control)				

*1. The maximum preset voltage and maximum preset current are provided for establishing a constant voltage operation when the operation point is at [rated output voltage and rated output current]. It does not guarantee power supply to the load exceeding the rated output voltage.

To establish a constant voltage operation at the operation point [rated output voltage and rated output current], set the output current (I Set) so that rated output current < I Set ≤ maximum preset current.

Likewise, to establish constant current operation, set the output voltage (V Set) so that rate output voltage < V Set ≤ maximum preset voltage.

*2. The difference between the actual output voltage and the preset value under constant voltage operation.

*3. ** % of rating denotes ** % of the rated output voltage.

*4. Output voltage fluctuation with respect to ± 10 % fluctuation of the nominal input voltage (ex. 100 VAC) under constant voltage operation.

*5. Output voltage fluctuation when the output voltage is set to the rated output voltage and the load is changed from rated load to no load (open load) under constant voltage operation.

*6. The time it takes for the output voltage fluctuation to recover from outside 0.1 % + 10 mV of the output voltage setting to within 0.1 % + 10 mV when the output current is changed from 100 % to 50 % or 50 % to 100 % of the rating under constant voltage operation. The output voltage at 100 % output current is used as a reference.

*7. At a measurement frequency bandwidth of 10 Hz to 20 MHz.

*8. At a measurement frequency bandwidth of 5 Hz to 1 MHz.

*9. The time it takes for the output voltage to rise from 10 % to 90 % of the rating when the OUTPUT is turned on.

*10. The time it takes for the output voltage to fall from 90 % to 10 % of the rating when the OUTPUT is turned off. The time it takes for the output voltage to fall to 60 V or less is within 10 s when the POWER switch is turned off under OUTPUT on and no load condition.

*11. At an ambient temperature range of 0 °C to 50 °C.

700W Type		PAS 10-70	PAS 20-36	PAS 40-18	PAS 60-12	PAS 80-9
Output Specifications (cont.)						
Current	Rated output current	70.00 A	36.00 A	18.00 A	12.00 A	9.000 A
	Maximum preset current (typ) *1	105 % of rating				
	Accuracy of setting *2	0.5 % of rating + 20 mA *3				
	Source effect *4	0.1 % of rating + 10 mA *3				
	Load effect *5	0.1 % of rating + 10 mA *3				
	Ripple noise (RMS) *6	185 mA	95 mA	48 mA	32 mA	24 mA
	Temperature coefficient (max) *7	200 ppm/ °C (during analog remote control)				
Series/Parallel operation						
Master-slave parallel operation *8		Up to 3 units including the master unit (same models only)				
Master-slave series operation *9		Up to 2 units including the master unit (same models only)				
Input Specifications						
Current (max) *10		10.0 A (100 VAC)/ 5.0 A (200 VAC)				
Inrush current (max) *11		70 Apeak				
Power (max) *10		1000 VA				
Power factor (typ) *12		0.980				
Efficiency (min) *13		70%				

- *1 The maximum preset voltage and maximum preset current are provided for establishing a constant current operation when the operation point is at [rated output voltage and rated output current]. It does not guarantee power supply to the load exceeding the rated output current.
To establish a constant voltage operation at the operation point [rated output voltage and rated output current], set the output current (I Set) so that rated output current < I Set ≤ maximum preset current.
Likewise, to establish constant current operation, set the output voltage (V Set) so that rated output voltage < V Set ≤ maximum preset voltage.
- *2 The difference between the actual output current and the preset value under constant current operation.
- *3 ** % of rating denotes ** % of the rated output current.
- *4 Output current fluctuation with respect to ± 10 % fluctuation of the nominal input voltage (ex. 100 VAC) under constant current operation.
- *5 Output current fluctuation when the output current is set to the rated output current and the load is changed from rated load to no load under constant current operation.

700W Type (cont.)		PAS 160-4	PAS 320-2	PAS 500-1.2	—	—
Output Specifications (cont.)						
Current	Rated output current	4.000 A	2.000 A	1200.0 mA	—	—
	Maximum preset current (typ) *1	105 % of rating			—	—
	Accuracy of setting *2	0.5 % of rating + 5 mA *3			—	—
	Source effect *4	0.1 % of rating + 5 mA *3			—	—
	Load effect *5	0.1 % of rating + 5 mA *3			—	—
	Ripple noise (RMS) *6	10 mA	5 mA		—	—
	Temperature coefficient (max) *7	200 ppm/ °C (during analog remote control)			—	—
Series/Parallel operation						
Master-slave parallel operation *8		Up to 3 units including the master unit (same models only)			—	—
Master-slave series operation *9		Up to 2 units including the master unit (same models only)	impossible		—	—
Input Specifications						
Current (max) *10		10.0 A (100 VAC)/ 5.0 A (200 VAC)				
Inrush current (max) *11		70 Apeak				
Power (max) *10		1000 VA				
Power factor (typ) *12		0.980				
Efficiency (min) *13		70%				

*6 At a measurement frequency bandwidth of 5 Hz to 1 MHz.

*7 At an ambient temperature range of 0 °C to 50 °C.

*8 The difference in the output current between the master unit and the slave unit is within approximately 3 % of the rating.

*9 The difference in the output voltage between the master unit and the slave unit is within approximately 3 % of the rating.

*10 Under rated load.

*11 Excludes the charge current component that flows through the capacitor of the internal EMC filter circuit immediately after the POWER switch is turned on (within approximately 1 ms).

*12 Standard value at an input voltage of 100 VAC under rated load.

*13 At an input voltage of 100 VAC under rated load.

700W Type	PAS 10-70	PAS 20-36	PAS 40-18	PAS 60-12	PAS 80-9
General					
Weight *1	Approx. 5 kg (11.02 lbs)				
Dimensions	See outline drawing				

700W Type (cont.)	PAS 160-4	PAS 320-2	PAS 500-1.2	—	—
General					
Weight *1	Approx. 5 kg (11.02 lbs)			—	—
Dimensions	See outline drawing			—	—

*1. Unit only. Does not include accessories.

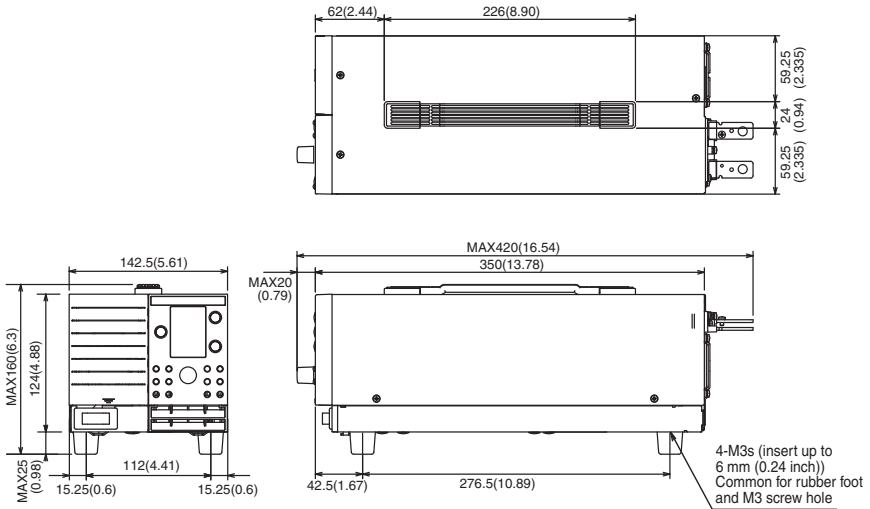

Unit: mm (inch)

Fig.8-2 700W type Outline Drawing

This page has been intentionally left blank.

1000W Type Specifications

1000W Type		PAS 10-105	PAS 20-54	PAS 40-27	PAS 60-18	PAS 80-13.5	
Output Specifications							
Power	Rated output power	1050 W	1080 W	1080 W	1080 W	1080 W	
Voltage	Rated output voltage	10.00 V	20.00 V	40.00 V	60.00 V	80.00 V	
	Maximum preset voltage (typ) ^{*1}	105 % of rating					
	Accuracy of setting ^{*2}	0.1 % of rating + 10 mV ^{*3}					
	Source effect ^{*4}	0.05 % of rating + 3 mV ^{*3}					
	Load effect ^{*5}	0.05 % of rating + 5 mV ^{*3}					
	Transient response ^{*6}	1 ms					
	Ripple noise	(p-p) ^{*7}	120 mV				
		(RMS) ^{*8}	14 mV				
	Rise time (max) ^{*9}	150 ms (rated load)/ 150 ms (no load)					
	Fall time (max) ^{*10}	200 ms (rated load)/ 1500 ms (no load)					
	Temperature coefficient (max) ^{*11}	100 ppm/ °C (during analog remote control)					

1000W Type (cont.)		PAS 160-6	PAS 320-3	PAS 500-1.8	—	—	
Output Specifications							
Power	Rated output power	960 W	960 W	900 W	—	—	
Voltage	Rated output voltage	160.0 V	320.0 V	500.0 V	—	—	
	Maximum preset voltage (typ) *1	105 % of rating			—	—	
	Accuracy of setting *2	0.1 % of rating + 10 mV *3			—	—	
	Power supply fluctuation *4	0.05 % of rating + 3 mV *3			—	—	
	Load fluctuation *5	0.05 % of rating + 5 mV *3			—	—	
	Transient response *6	2 ms			—	—	
	Ripple noise	(p-p) *7	120 mV	170 mV	240 mV	—	—
		(RMS) *8	20 mV	30 mV	40 mV	—	—
	Rise time (max) *9	250 ms (rated load)/ 150 ms (no load)					
	Fall time (max) *10	400 ms (rated load)/ 3000 ms (no load)					
	Temperature coefficient (max) *11	100 ppm/ °C (during analog remote control)					

*1. The maximum preset voltage and maximum preset current are provided for establishing a constant voltage operation when the operation point is at [rated output voltage and rated output current]. It does not guarantee power supply to the load exceeding the rated output voltage.

To establish a constant voltage operation at the operation point [rated output voltage and rated output current], set the output current (I Set) so that rated output current < I Set ≤ maximum preset current.

Likewise, to establish constant current operation, set the output voltage (V Set) so that rate output voltage < V Set ≤ maximum preset voltage.

*2. The difference between the actual output voltage and the preset value under constant voltage operation.

*3. ** % of rating denotes ** % of the rated output voltage.

*4. Output voltage fluctuation with respect to ± 10 % fluctuation of the nominal input voltage (ex. 100 VAC) under constant voltage operation.

*5. Output voltage fluctuation when the output voltage is set to the rated output voltage and the load is changed from rated load to no load (open load) under constant voltage operation.

*6. The time it takes for the output voltage fluctuation to recover from outside 0.1 % + 10 mV of the output voltage setting to within 0.1 % + 10 mV when the output current is changed from 100 % to 50 % or 50 % to 100 % of the rating under constant voltage operation. The output voltage at 100 % output current is used as a reference.

*7. At a measurement frequency bandwidth of 10 Hz to 20 MHz.

*8. At a measurement frequency bandwidth of 5 Hz to 1 MHz.

*9. The time it takes for the output voltage to rise from 10 % to 90 % of the rating when the OUTPUT is turned on.

*10. The time it takes for the output voltage to fall from 90 % to 10 % of the rating when the OUTPUT is turned off. The time it takes for the output voltage to fall to 60 V or less is within 10 s when the POWER switch is turned off under OUTPUT on and no load condition.

*11. At an ambient temperature range of 0 °C to 50 °C.

1000W Type		PAS 10-105	PAS 20-54	PAS 40-27	PAS 60-18	PAS 80-13.5
Output Specifications (cont.)						
Current	Rated output current	105.0 A	54.00 A	27.00 A	18.00 A	13.50 A
	Maximum preset current (typ) *1	105 % of rating				
	Accuracy of setting *2	0.5 % of rating + 20 mA *3				
	Source effect *4	0.1 % of rating + 15 mA *3				
	Load effect *5	0.1 % of rating + 15 mA *3				
	Ripple noise (RMS) *6	277 mA	143 mA	71 mA	48 mA	36 mA
	Temperature coefficient (max) *7	200 ppm/ °C (during analog remote control)				
Series/Parallel operation						
Master-slave parallel operation *8		Up to 2 units including the master unit (same models only)				
Master-slave series operation *9		Up to 2 units including the master unit (same models only)				
Input Specifications						
Current (max) *10		15.0 A (100 VAC)/ 7.5 A (200 VAC)				
Inrush current (max) *11		105 Apeak				
Power (max) *10		1500 VA				
Power factor (typ) *12		0.980				
Efficiency (min) *13		70%				

- *1 The maximum preset voltage and maximum preset current are provided for establishing a constant current operation when the operation point is at [rated output voltage and rated output current]. It does not guarantee power supply to the load exceeding the rated output current.
To establish a constant voltage operation at the operation point [rated output voltage and rated output current], set the output current (I Set) so that rated output current < I Set ≤ maximum preset current.
Likewise, to establish constant current operation, set the output voltage (V Set) so that rated output voltage < V Set ≤ maximum preset voltage.
- *2 The difference between the actual output current and the preset value under constant current operation.
- *3 ** % of rating denotes ** % of the rated output current.
- *4 Output current fluctuation with respect to ± 10 % fluctuation of the nominal input voltage (ex. 100 VAC) under constant current operation.
- *5 Output current fluctuation when the output current is set to the rated output current and the load is changed from rated load to no load under constant current operation.

1000W Type (cont.)		PAS 160-6	PAS 320-3	PAS 500-1.8	—	—
Output Specifications (cont.)						
Current	Rated output current	6.000 A	3.000 A	1800.0 mA	—	—
	Maximum preset current (typ) *1	105 % of rating			—	—
	Accuracy of setting *2	0.5 % of rating + 5 mA *3			—	—
	Source effect *4	0.1 % of rating + 5 mA *3			—	—
	Load effect *5	0.1 % of rating + 5 mA *3			—	—
	Ripple noise (RMS) *6	15 mA	10 mA	5 mA	—	—
	Temperature coefficient (max) *7	200 ppm/ °C (during analog remote control)			—	—
Series/Parallel operation						
Master-slave parallel operation *8		Up to 2 units including the master unit (same models only)			—	—
Master-slave series operation *9		Up to 2 units including the master unit (same models only)	impossible		—	—
Input Specifications						
Current (max) *10		15.0 A (100 VAC)/ 7.5 A (200 VAC)				
Inrush current (max) *11		105 Apeak				
Power (max) *10		1500 VA				
Power factor (typ) *12		0.980				
Efficiency (min) *13		70%				

*6 At a measurement frequency bandwidth of 5 Hz to 1 MHz.

*7 At an ambient temperature range of 0 °C to 50 °C.

*8 The difference in the output current between the master unit and the slave unit is within approximately 3 % of the rating.

*9 The difference in the output voltage between the master unit and the slave unit is within approximately 3 % of the rating.

*10 Under rated load.

*11 Excludes the charge current component that flows through the capacitor of the internal EMC filter circuit immediately after the POWER switch is turned on (within approximately 1 ms).

*12 Standard value at an input voltage of 100 VAC under rated load.

*13 At an input voltage of 100 VAC under rated load.

1000W Type	PAS 10-105	PAS 20-54	PAS 40-27	PAS 60-18	PAS 80-13.5
General					
Weight *1	Approx. 7 kg (15.43 lbs)				
Dimensions	See outline drawing				

1000W Type (cont.)	PAS 160-6	PAS 320-3	PAS 500-1.8	—	—
General					
Weight *1	Approx. 7 kg (15.43 lbs)			—	—
Dimensions	See outline drawing			—	—

*1. Unit only. Does not include accessories.

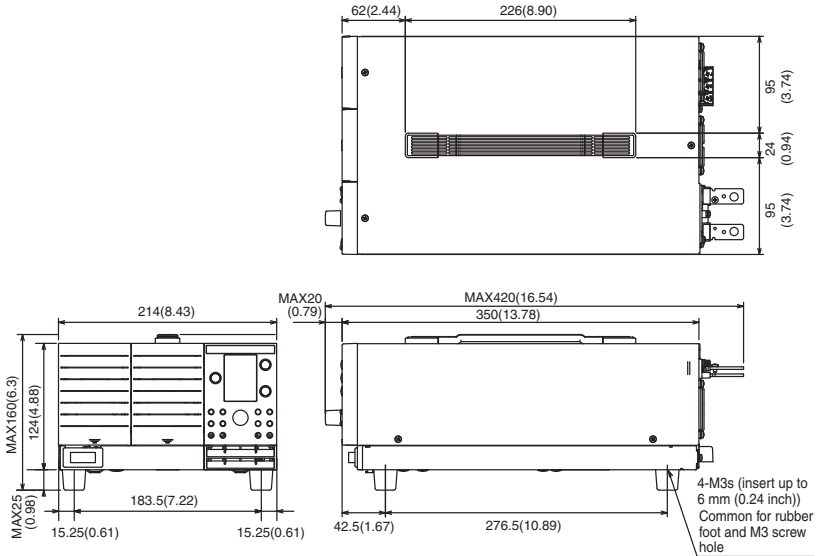

Unit: mm (inch)

Fig.8-3 1000W type Outline Drawing

Index

A

AC INPUT	6-5
AC power cord	1-3
Accessories	1-2
ADDRESS	6-1
Alarm	2-7
Alarm Signal	2-9
Analog remote control	4-1
Analog remote control connector kit	P-3

C

Calibration	7-8
Voltage	7-12
Calibration Mode	7-10
CC Power Supply	2-4
Cleaning	7-1
Cleaning the Panel	7-1
CONFIG	3-7, 6-2
Constant Current Power Supply	3-12
Constant Voltage Power Supply	3-11
CURRENT/PWR DSPL	6-4
CV Power Supply	2-4

D

DC OUTPUT	6-6
Dial	6-4
Digital remote control	4-1
Display section	6-2
Dust Filter	7-2

E

Exhaust port	6-6
EXT OUTPUT logic	3-9
External Contact	4-17, 4-19
External Monitoring	4-21

External Resistance	4-8, 4-14
External Voltage	4-5, 4-11

F

Factory default setting	3-2
firmware version	P-2

G

Grounding	1-6
-----------	-----

I

Inrush Current	2-1
Inspection	7-8
Isolation voltage	2-10

J

J1	6-6
J1 Connector	4-2

L

Load	2-1
Load Cable	3-13
Current capacity	3-13
Withstand voltage	3-14
LOCK	6-2
LOCK Function	3-19

M

Master unit	5-1
Master-Slave Parallel Operation	5-1, 5-8
Master-Slave Series Operation	5-1, 5-2
Master-slave series/parallel function	3-9

O

OCP (Overcurrent Protection)	
-----	2-8, 3-6
calibration	-----7-15
OHP (Overheat Protection)	----2-8
OP01-PAS	-----P-3
Options	-----P-3
OUTPUT	-----6-2
Output Current	
Controlling	-----4-11, 4-14
Output ON/OFF	-----4-17
Output Shutdown	-----4-19
Output Terminal	
Grounding	-----2-10
OUTPUT terminal cover	----3-17
Output Voltage	
Controlling	-----4-5, 4-8
OVP (Overvoltage Protection)	--3-4
Calibration	-----7-13
OVP/OCP	-----6-4

P

POWER	-----6-1
Power	
Turning on	-----3-1
Power Display	-----3-18
Power Supply Controller	----4-1
POWER switch	
Protection circuit is activated	3-9
PWR ON OUTPUT	-----3-9

R

Rack mount frame	-----P-3
Remote Sensing	-----3-8, 3-19

S

Sensing terminal	-----6-6
SET	-----6-4
Shield	-----4-7, 4-13
SHIFT	-----6-2

SHUT (Shutdown)	-----2-9
signal terminal	
Maximum rating	-----4-22
Slave unit	-----5-1

T

TERMN	-----3-9
TP-BUS	-----6-6

V

Version	-----P-1
version	-----P-2
VOLTAGE/PWR DSPL	-----6-4

KIKUSUI ELECTRONICS CORP.

1-1-3 Higashiyamata, Tsuzuki-ku, Yokohama,
224-0023, Japan

Tel: +81-45-593-7570 Fax: +81-45-593-7571



Website

<http://www.kikusui.co.jp/en>