

REGULATED DC POWER SUPPLY

# *PAD-L SERIES*

OPERATION MANUAL

## **PAD-L SERIES TYPE III**

**PAD16-100L**

**PAD35-50L**

**PAD35-60L**

**PAD60-35L**

**PAD110-20L**

**PAD250-8L**

## **PAD-L SERIES TYPE IV**

**PAD35-100L**

**PAD60-60L**

**PAD110-30L**

**PAD250-15L**

## **PAD-L SERIES TYPE V**

**PAD35-200L**

**PAD60-120L**

**PAD110-60L**



Part No. Z1-002-302, IB002642

Jun.2003

### **Use of Operation Manual**

Please read through and understand this Operation Manual before operating the product. After reading, always keep the manual nearby so that you may refer to it as needed. When moving the product to another location, be sure to bring the manual as well.

If you find any incorrectly arranged or missing pages in this manual, they will be replaced. If the manual it gets lost or soiled, a new copy can be provided for a fee. In either case, please contact Kikusui distributor/agent, and provide the "Kikusui Part No." given on the cover.

This manual has been prepared with the utmost care; however, if you have any questions, or note any errors or omissions, please contact Kikusui distributor/agent.

The contents of this Operation Manual may not be reproduced, in whole or in part, without the prior consent of the copyright holder.

The specifications of this product and the contents of this Operation Manual are subject to change without prior notice.

# Power Requirements of this Product

Power requirements of this product have been changed and the relevant sections of the Operation Manual should be revised accordingly. (Revision should be applied to items indicated by a check mark )

## Input voltage

The input voltage of this product is \_\_\_\_\_ VAC,  
and the voltage range is \_\_\_\_\_ to \_\_\_\_\_ VAC.

Use the product within this range only.

## Input fuse

The rating of this product's input fuse is \_\_\_\_\_ A, \_\_\_\_\_ VAC, and \_\_\_\_\_.

### **⚠ WARNING**

- To avoid electrical shock, always disconnect the AC power cord or turn off the switch on the switchboard before attempting to check or replace the fuse.
- Use a fuse element having a shape, rating, and characteristics suitable for this product. The use of a fuse with a different rating or one that short circuits the fuse holder may result in fire, electric shock, or irreparable damage.

## AC power cord

The product is provided with AC power cords described below. If the cord has no power plug, attach a power plug or crimp-style terminals to the cord in accordance with the wire colors specified in the drawing.

### **⚠ WARNING**

- The attachment of a power plug or crimp-style terminals must be carried out by qualified personnel.

### Without a power plug

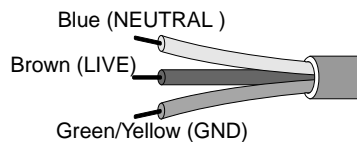

### Without a power plug

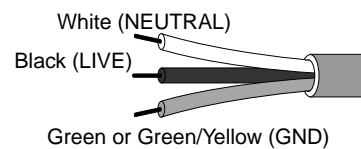

### Plugs for USA

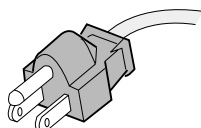

### Plugs for Europe

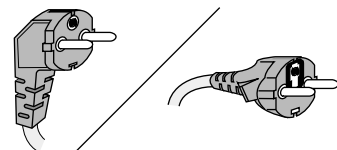

### Provided by Kikusui distributor/agent

Kikusui distributor/agent can provide you with suitable AC power cord.  
For further information, contact Kikusui distributor/agent.



# Safety Symbols

For the safe use and safe maintenance of this product, the following symbols are used throughout this manual and on the product. Understand the meanings of the symbols and observe the instructions they indicate (the choice of symbols used depends on the products).



Indicates that a high voltage (over 1,000 V) is used here. Touching the part causes a possibly fatal electric shock. If physical contact is required by your work, start work only after you make sure that no voltage is output here.

**DANGER**

Indicates an imminently hazardous situation which, if ignored, will result in death or serious injury.



Indicates a potentially hazardous situation which, if ignored, could result in death or serious injury.



Indicates a potentially hazardous situation which, if ignored, may result in damage to the product and other property.



Shows that the act indicated is prohibited.



Is placed before the sign “DANGER,” “WARNING,” or “CAUTION” to emphasize these. When this symbol is marked on the product, see the relevant sections in this manual.



Indicates an earth ground terminal.



Indicates a chassis ground terminal.

# Safety Precautions

The following safety precautions must be observed to avoid fire hazard, electrical shock, accidents, and other failures. Keep them in mind and make sure that all of them are observed properly.



## Users

- This product must be used only by qualified personnel who understand the contents of this operation manual.
- If it is handled by disqualified personnel, personal injury may result. Be sure to handle it under supervision of qualified personnel (those who have electrical knowledge.)
- This product is not designed or manufactured for general home or consumer use.

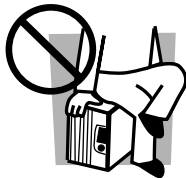

## Purposes of use

- Do not use the product for purposes other than those described in the operation manual.

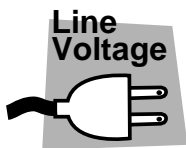

## Input power

- Use the product with the specified input power voltage.
- For applying power, use the AC power cord provided. For PAD-L series TYPE III models, the supplied AC power cord cannot be used if the input power voltage is changed to 100 V. In such a case, use an appropriate power cord. For details, see the relevant page of this operation manual.



## Fuse

- When replacing a fuse, use the one which has appropriate shape, ratings, and specifications. For details, see the relevant page of this operation manual.

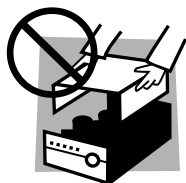

## Cover

- There are parts inside the product which may cause physical hazards. When the cover needs to be removed to make product adjustments, always follow the procedures given in the corresponding section of the Operation Manual.

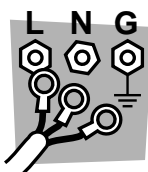

## Installation

- When installing products be sure to observe "Precautions for Installation" described in this manual.
- To avoid electrical shock, connect the protective ground terminal to electri-

cal ground (safety ground).

- When applying power to the products from a switchboard, be sure work is performed by a qualified and licensed electrician or is conducted under the direction of such a person.
- Use the caster locks or stopper bolts to secure the power supply to an installation location.



### **Relocation**

- Turn off the power switch and then disconnect all cables when relocating the product.
- Unlock the stoppers (caster locks and/or stopper bolts).
- Use two or more persons when relocating the product.
- Use extra precautions such as using more people when relocating into or out of present locations including inclines or steps. Also handle carefully when relocating tall products as they can fall over easily.
- Be sure the operation manual be included when the product is relocated.



### **Operation**

- Before starting operations, inspect for abnormalities affecting the input power voltage. Examine the exterior of the AC power cord. Cut off the power supply before performing these inspections.
- If any abnormality or failure is detected in the products, stop using it immediately. Disconnect the AC power cord from the switchboard. Be careful not to allow the product to be used before it is completely repaired.
- For output wiring or load cables, use connection cables with larger current capacity.
- Do not disassemble or modify the product. If it must be modified, contact Kikusui distributor/agent.



### **Maintenance and checking**

- To avoid electrical shock, be absolutely sure to stop applying power before performing maintenance or checking.
- To maintain performance and safe operation of the product, it is recommended that periodic maintenance, checking, cleaning, and calibration be performed.



### **Service**

- Internal service is to be done by Kikusui service engineers. If the product must be adjusted or repaired, contact Kikusui distributor/agent.

# Arrangement of this manual

This Operation Manual is made up of the following sections.

## **Preface**

Provides a brief description of the product and specifies its features.

## **Chapter 1 Setup**

Explains the preliminary procedure for using the PAD-L series, starting with unpacking.

## **Chapter 2 Precautions and Preparations for Use**

Contains essential descriptions that must be understood by the user.

## **Chapter 3 Basic Operation**

Describes the basic operations managed from the front panel of the PAD-L series.

## **Chapter 4 Applied Operation**

Describes the remote sensing, remote control, parallel operation, and series operation.

## **Chapter 5 Names and Functions of Controls**

Explains the designation and the function of the switches, indicators, terminals, and other components on the front and rear panels.

## **Chapter 6 Maintenance**



Explains the maintenance and adjustment of the PAD-L series. The chapter also describes some symptoms of possible problems encountered during use of the PAD-L series, along with appropriate remedies.

## **Chapter 7 Specifications**

Describes the electrical and mechanical specifications of the PAD-L series, as well as its accessories.



# Contents

Power Requirements of this Product	I
 Safety Symbols	III
 Safety Precautions	IV
Preface	P-1
About this manual	P-1
Outline of the PAD-L series	P-2
Options	P-2
Chapter 1 Setup	1-1
1.1 Checking at unpacking	1-2
1.2 Installation	1-3
1.3 Precautions for moving	1-6
1.4 Changing the input power voltage (TYPE III models only)	1-7
1.5 Connecting the AC power cord	1-10
1.6 Grounding	1-12
Chapter 2 Precautions and Preparations for Use	2-1
2.1 Inrush current	2-2
2.2 Negative voltage	2-2
2.3 Load	2-3
2.3.1 When load current has peaks or is pulse-shaped	2-3
2.3.2 When a load generates a reverse current to the power supply	2-4
2.3.3 In case of load with accumulated energy, such as batteries	2-5
2.4 Constant-voltage and constant-current power supplies	2-6
2.5 Protective circuits	2-8
2.6 Grounding the output terminal	2-9
Chapter 3 Basic Operation	3-1
3.1 Turning on the power	3-2
3.2 Basic operation	3-4
3.2.1 OVP (OverVoltage Protection) trip point presetting	3-4
3.2.2 Using as a constant voltage power supply	3-6
3.2.3 Using as a constant current power supply	3-7
3.3 Connecting load	3-8
3.3.1 load cables	3-8
3.3.2 Connection to the output terminals	3-10
3.4 Using the guard cap(s)	3-11

Chapter 4 Applied Operation	4-1
4.1 Remote sensing	4-2
4.2 CV mode by remote control	4-4
4.2.1 Output voltage control (I) with external resistor	4-4
4.2.2 Output voltage control (II) with external resistor	4-6
4.2.3 Output voltage control with external voltage	4-9
4.3 Output ON/OFF control	4-12
4.3.1 Output ON/OFF control (I)	4-12
4.3.2 Output ON/OFF control (II)	4-14
4.4 CC mode by remote control	4-16
4.4.1 Output current control with external resistor	4-16
4.4.2 Output current control with external voltage	4-18
4.5 Master-slave-control parallel operation	4-22
4.6 Master-slave-control series operation	4-26
4.7 Shutting off the POWER switch	4-30
4.8 Constant current charge of a battery/capacitor	4-32
Chapter 5 Names and Functions of Controls	5-1
5.1 Front panel	5-2
5.2 Rear panel	5-6
Chapter 6 Maintenance	6-1
6.1 Cleaning	6-2
6.2 Inspection	6-2
6.3 Adjustment	6-3
6.3.1 Test equipment required	6-3
6.3.2 Environment	6-3
6.3.3 Removing the cover	6-4
6.3.4 Adjustment procedure	6-6
6.4 Replacing the input fuse (TYPE III and TYPE IV models only)	6-14
6.5 Malfunctions and Causes	6-17
Chapter 7 Specifications	7-1
7.1 TYPE III models specifications	7-2
7.2 TYPE IV models specifications	7-6
7.3 TYPE V models specifications	7-10
Index	I-1

# Preface

## About this manual

The PAD-L series is classified depending on output capacity. This Operation Manual describes the PAD-L series, including the specific types named below.

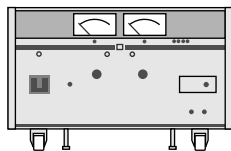

**PAD-L SERIES TYPE III**  
PAD16-100L, PAD35-50L,  
PAD35-60L, PAD60-35L,  
PAD110-20L, PAD250-8L

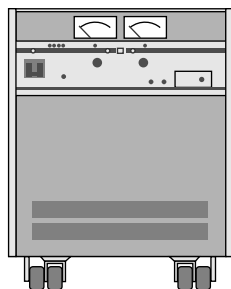

**PAD-L SERIES TYPE IV**  
PAD35-100L,  
PAD60-60L,  
PAD110-30L,  
PAD250-15L

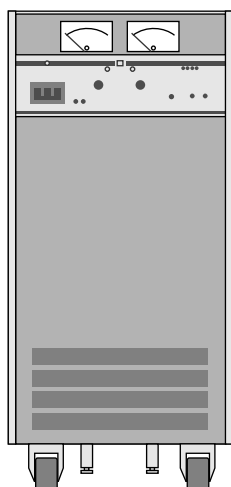

**PAD-L SERIES TYPE V**  
PAD35-200L,  
PAD60-120L,  
PAD110-60L

Fig. P-1 Models and types covered by this manual

# Outline of the PAD-L series

The PAD-L series represents a line of universal industrial-grade power supplies that provide high reliability and excellent electrical characteristics. They are ideal for use as variable power supplies in research and experiments, or as stationary power supplies for long-term aging.

The PAD-L series offers the following features:

## Improved power factors at low output voltage

The PAD-L series uses a choke input circuit in the rectifier smoothing circuit, reducing the apparent input power and improving the power factor; therefore, a smaller power transformer is realized. This is one of the reasons for the compact size and light weight of the PAD-L series.

## Superior temperature coefficient

A low-temperature drift of 50 ppm/°C (standard value) is achieved through selection of parts, circuit improvements, and handling of heat radiation by forced air cooling. (Constant voltage characteristics)

## Prompt transient response

Having a high-speed transient response characteristic of 50  $\mu$ s (standard value) (100  $\mu$ s for the TYPE V models), the PAD-L series is capable of handling abrupt changes in load.

## Other features

A 10-turn potentiometer is used to set the output voltage in fine adjustments from 0 V to the rated voltage.

Use of a CURRENT/VOLT. LIMIT switch allows a constant voltage or constant current set-value to be checked during operations in addition to presetting current and voltage.

For safety, the PAD-L series has internal voltage detection, current detection, and temperature detection circuits, as well as a standard built-in overvoltage protection (OVP) circuit that permits voltage-setting from the front panel.

The overvoltage protection (OVP) circuit found in the TYPE V models provides a preset function that allows you to check the OVP set voltage even when the power supply is in use.

## Options

For TYPE III and TYPE IV models, the following options are offered for incorporation into a rack.

---

**NOTE**

- The TYPE V models cannot be incorporated in a rack.
  - Provided with inlets for forced air cooling, the PAD-L series requires a blank panel if it is to be installed on a rack. See Fig. P-2 or Fig. P-4.
- 

For details, contact Kikusui distributor/agent.

## Options for incorporation into a rack for TYPE III models

Table P-1 Brackets and blank panels for TYPE III models

	Inch rack EIA standard	Millimeter rack JIS standard	Remarks
Bracket	BH6A	BH6AM	
Blank panel	BP191	BP1H	One-unit width, plate type
	BP191-M	BP1H-M	One-unit width, mesh type

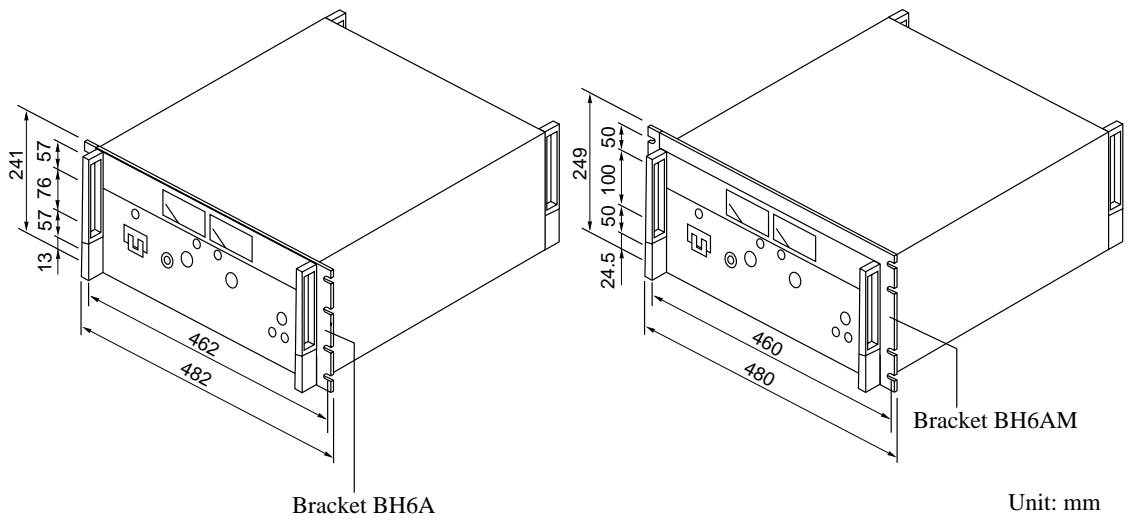
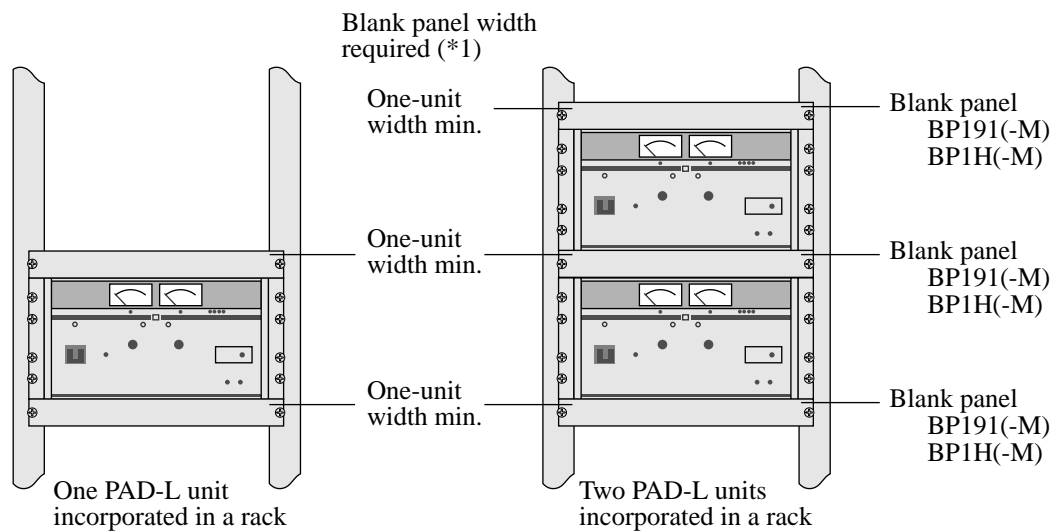

Fig. P-1 The TYPE III model with brackets



\*1: One-unit width; JIS: 50 mm, EIA: 44.45 mm

Fig. P-2 The TYPE III model with blank panels

## Options for incorporation into a rack for TYPE IV models

Table P-2 Brackets and blank panels for TYPE IV models

	Inch rack EIA standard	Millimeter rack JIS standard	Remarks
Bracket	BH12	BH12M	
Blank panel	BP191	BP1H	One-unit width, plate type
	-	BP2H	Two-unit width, plate type
	BP191-M	BP1H-M	One-unit width, mesh type
	-	BP2H-M	Two-unit width, mesh type

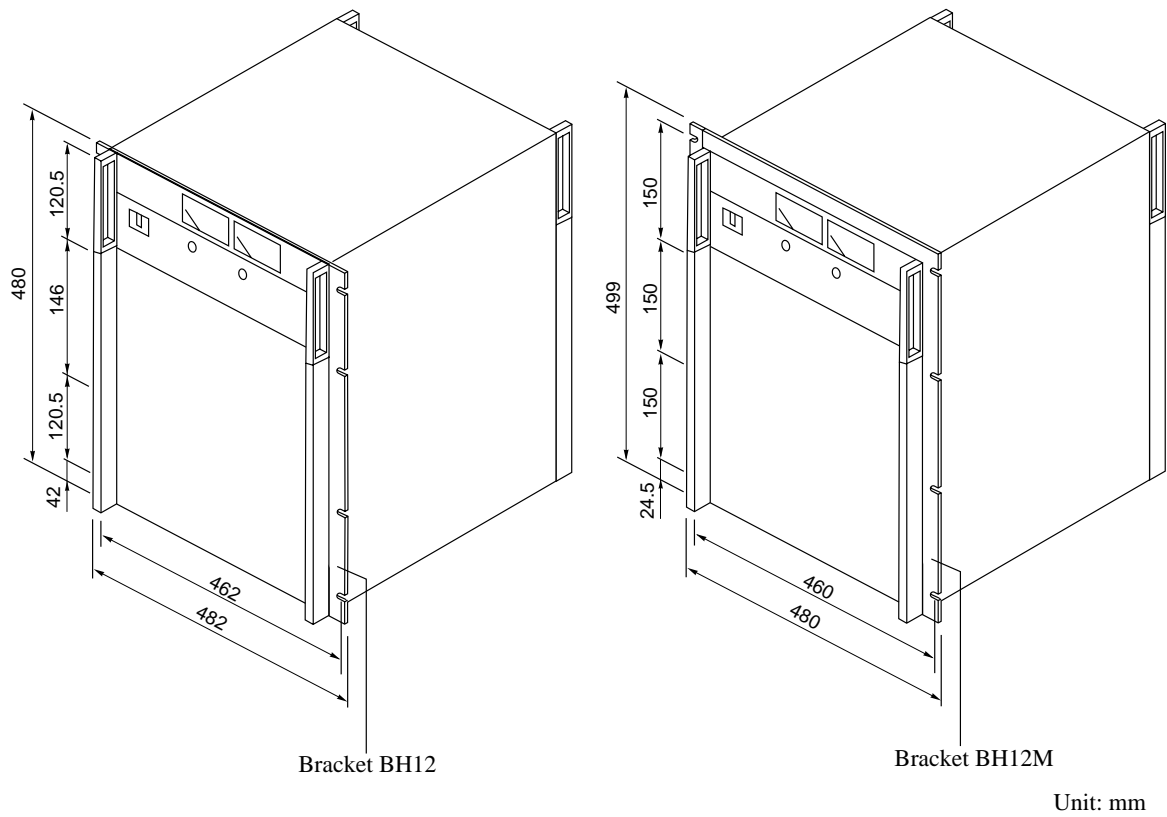
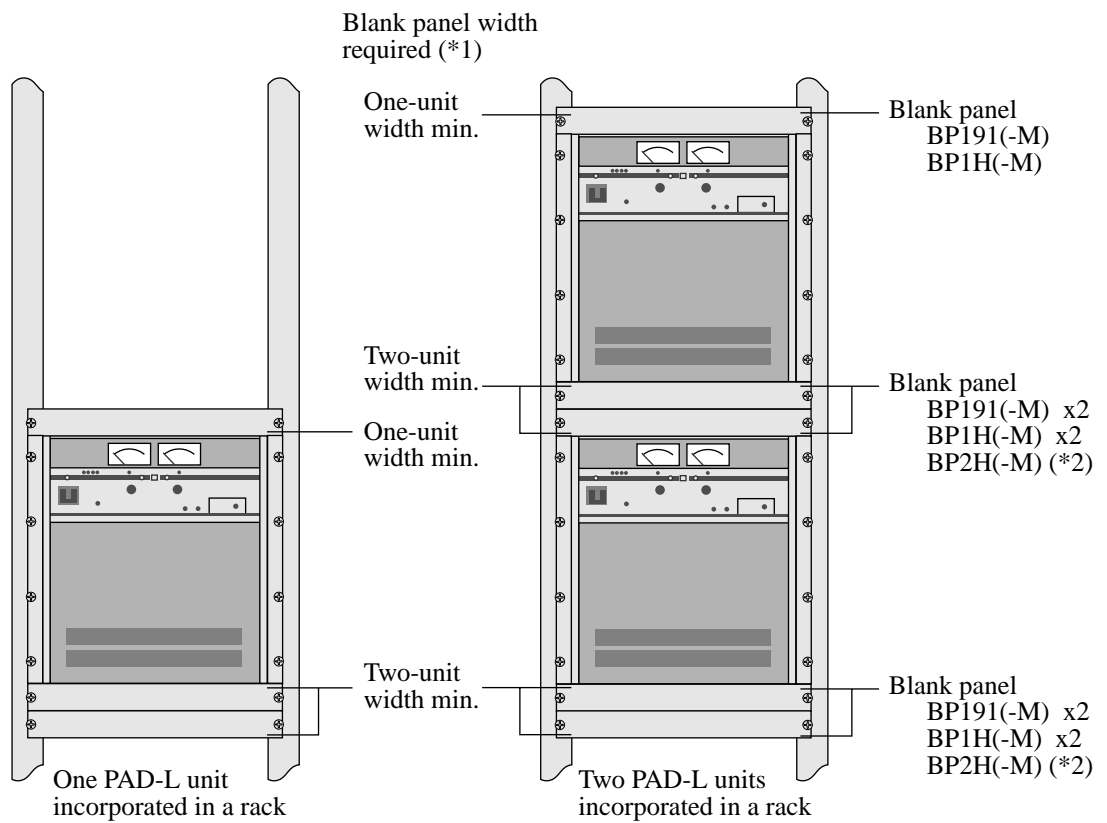

Fig. P-3 The TYPE IV model with brackets



\*1: One-unit width; JIS: 50 mm, EIA: 44.45 mm

\*2: A two-unit width BP2H (-M) can be used in a rack complying with the JIS standard.

Fig. P-4 The TYPE IV model with blank panels





# 1

## Chapter 1 Setup

Describes the necessary procedure from unpacking to preparation before use.

# 1.1 Checking at unpacking

Upon receiving this product, make sure the package contains the necessary accessories and has not been during transportation. Accessories are shown in Table 1-1.

If any part is damaged or missing, contact Kikusui distributor/agent.

Table 1-1 Accessories

Type III		PAD 16-100L	PAD 35-50L	PAD 35-60L	PAD 60-35L	PAD 110-20L	PAD 250-8L
Operation manual		1 copy (Z1-002-302)					
Input fuse (spare)	For 200 V	1 piece (30 A), (99-00-2901)					
	For 100 V	1 piece (50 A), (99-00-2902)		1 piece (60 A), (99-00-2903)		1 piece (50 A), (99-00-2902)	
Power cord		1 piece, 3-core cabtyre cable for 200 VAC input (3.5 mm <sup>2</sup> , approx. 3 m), (85-10-0401)					
Voltage check chip		2 pieces (87-12-0000)					
Guard cap (with one hexagon wrench)		1 piece (P2-000-351)			2 pieces (P2-000-351)		
Output terminal cover		1 piece (*1) (P1-070-011)					

Type IV		PAD 35-100L	PAD 60-60L	PAD 110-30L	PAD 250-15L
Operation manual		1 copy (Z1-002-302)			
Input fuse (spare)		1 piece (50 A), (99-00-2902)			
Power cord		1 piece, 3-core cabtyre cable (8mm <sup>2</sup> , approx. 4 m), (85-10-0441)			
Voltage check chip		2 pieces (87-12-0000)			
Guard cap (with one hexagon wrench)		1 piece (P2-000-351)			
Output terminal cover		1 piece (*1) (P1-070-011)			1 piece (*2) (CN)

Type V		PAD 35-200L	PAD 60-120L	PAD 110-60L
Operation manual		1 copy (Z1-002-302)		
Power cord		1 piece, 3-core cabtyre cable (14mm <sup>2</sup> , approx. 4 m), (85-10-0461)		
Voltage check chip		2 pieces (87-12-0000)		
Guard cap (with one hexagon wrench)		1 piece (P2-000-351)		
Output terminal cover		1 piece (*1) (P1-070-011)		1 piece (*2) (CN)

\*1: Mounted on the unit, with four mounting screws

\*2: Mounted on the unit, with two mounting screws

## 1.2 Installation

### Precautions for installation

Be sure to observe the following precautions when installing the power supply.

■ **Do not use the power supply in a flammable atmosphere.**

To prevent explosion or fire, do not use the power supply near alcohol, thinner, or other combustible materials, or in an atmosphere containing such vapors.

■ **Avoid locations where the power supply is exposed to high temperatures or direct sunlight.**

Do not locate the power supply near a heater or in areas subject to drastic temperature changes.

Operating temperature range: 0°C to 40°C

Storage temperature range: -10°C to +60°C

■ **Avoid humid environments.**

Do not locate the power supply in a high-humidity environment—near a boiler, humidifier, or water supply.

Operating humidity range: 10% to 90% RH  
(no dew condensation is allowed)

Storage humidity range: 70% RH or less  
(no dew condensation is allowed)

Condensation may occur even within the operating humidity range. In that case, do not start using the power supply until the location is completely dry.

■ **Do not place the power supply in a corrosive atmosphere.**

Do not install the power supply in a corrosive atmosphere or one containing sulfuric acid mist or the like. This may cause corrosion of various conductors and imperfect contact with connectors, leading to malfunction and failure, or in the worst case, a fire.

Modification may allow the unit to cope with such an atmosphere. If the unit is to be used in such an atmosphere, contact your Kikusui distributor/agent.

■ **Do not locate the power supply in a dusty environment.**

Dirt and dust in the power supply may cause electrical shock or fire.

■ **Do not use the power supply where ventilation is poor.**

The power supply employs a forced air cooling system. Air is taken in from intake ports located on the power supply's sides and front, and is exhausted from the rear. Prepare sufficient space around the power supply so that the intake ports and exhaust port are always completely unobstructed. Otherwise, heat may accumulate in the power supply, resulting in fire.

---

## Precautions for installation (continued)

■ **Do not place any object on the power supply.**

Particularly a heavy one, as doing so could result in a malfunction.

■ **Do not place the power supply on a tilted surface or in a location subject to vibrations.**

If placed on a non-level surface or in a location subject to vibration, the power supply may fall, resulting in damage and injury.

■ **Do not use the power supply in locations affected by strong magnetic or electric fields.**

Operation in a location subject to magnetic or electric fields may cause the power supply to malfunction, resulting in electrical shock or fire.

■ **Do not use the power supply in locations where highly-sensitive measuring instruments or receivers are nearby.**

Such instruments may be affected by the noise generated by the unit.

## To secure the power supply at an installation site

The PAD-L power supplies are provided with casters for easy mobility. To avoid unintended movement while the unit is in use, use the stoppers (caster locks and/or stopper bolts) to secure it to a particular location. The method of securing it in position differs from TYPE models. See Fig. 1-1.

---

**NOTE**

- To avoid possible damage to the floor when locking the power supply to a particular location with the stopper bolts, place a rubber sheet or similar material between the stopper bolt and the floor.
- 

### Locking the TYPE III models

Two stopper bolts are provided on the front panel side of the bottom face. Lock the power supply by adjusting the stopper bolts so that they just touch the floor. The casters have no locking mechanism.

### Locking the TYPE IV models

The casters on the front panel side of the bottom face are provided with a locking mechanism. Tilt the caster lever to the ON position to lock that caster.

### Locking the TYPE V models

The front and rear sides of the bottom of the power supply are provided with one stopper bolt each. To lock the unit, adjust the stopper bolts so that they just touch the floor of an installation site.

The caster on the front panel side is also provided with a locking mechanism. Tilt the caster lever to the ON position to lock that caster.

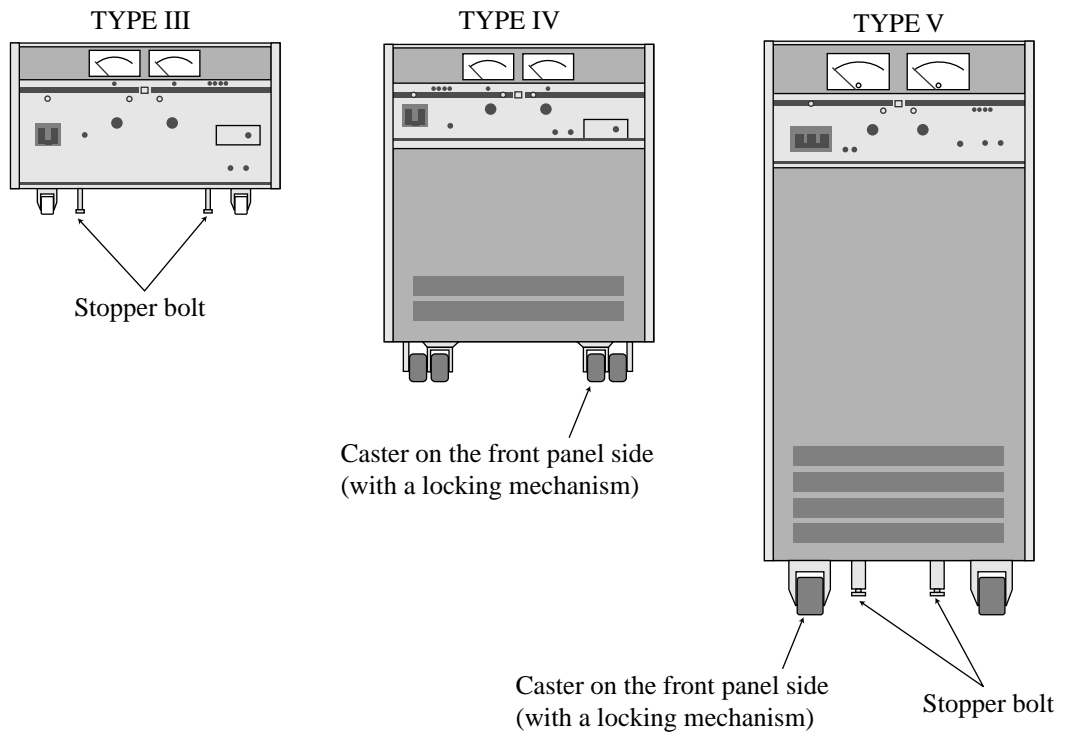

Fig. 1-1 Stopper

---

## 1.3 Precautions for moving

When moving or transporting the power supply to an installation site, observe the following precautions.

■ **Turn the POWER switch off.**

Moving the power supply with the power on may result in electrical shock or damage.

■ **Remove all wirings connected.**

Moving the power supply with cables connected may break the cables or cause the power supply to fall, resulting in injury.

■ **Unlocking the stoppers**

Before moving the power supply, you must unlock the stoppers used to secure the power supply at the installation site (caster locks and/or stopper bolts). Any attempt to move the power supply without unlocking the securing devices may cause it to topple over, resulting in injury or equipment damage.

■ **Do not move the power supply by yourself; enlist assistance.**

Even the lightest TYPE III model in the PAD-L series is approximately 60 kg in weight. Moving the power supply requires at least two persons. Never attempt to move the power supply by yourself. Watch for inclined surfaces and steps.

## 1.4 Changing the input power voltage (TYPE III models only)

The input power voltage of the TYPE III model is factory-set to 200 V. This can be changed to 100 V by modifying the connections of the input terminals of the main power transformer.

You can contact your Kikusui distributor/agent to change the input power voltage. To perform this work yourself, follow the procedure given below.

- 
- ⚠ WARNING**
- **Changing the input power voltage requires removal of the top covers of TYPE III models. This work must be carried out by qualified personnel having sufficient expertise and familiarity with the following procedures and safety precautions.**
  - **After the input power voltage is changed from 200 V to 100 V, the current capacity of the supplied AC power cord will be insufficient. The AC power cord must be replaced with a cable of the necessary current capacity.**
- 

### Input power voltage changing procedure (TYPE III models only)

1. Confirm by inspection that the AC power cord has not been connected to the input terminal board of the unit.
2. Remove the top panel. See Fig. 1-2.

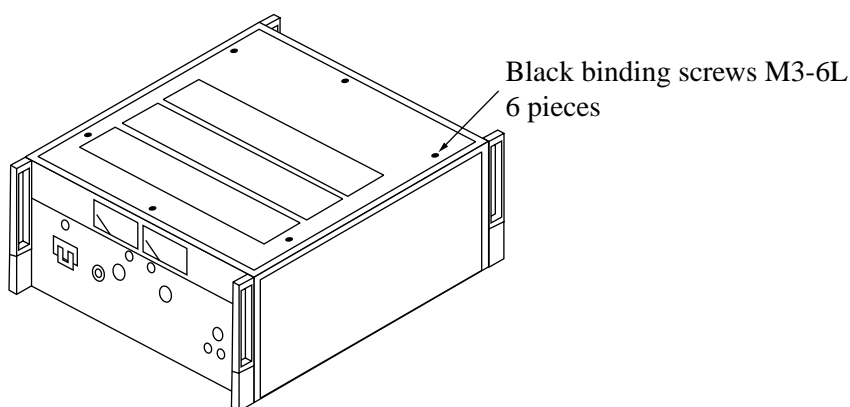

Fig. 1-2 Removing the top panel from the TYPE III model

## Input power voltage changing procedure (continued)

3. Change the connections of the input terminals of the main power transformer shown in Fig. 1-3 to the condition shown in Fig. 1-4.

The transformer's input terminals are either A or B, depending on the model.

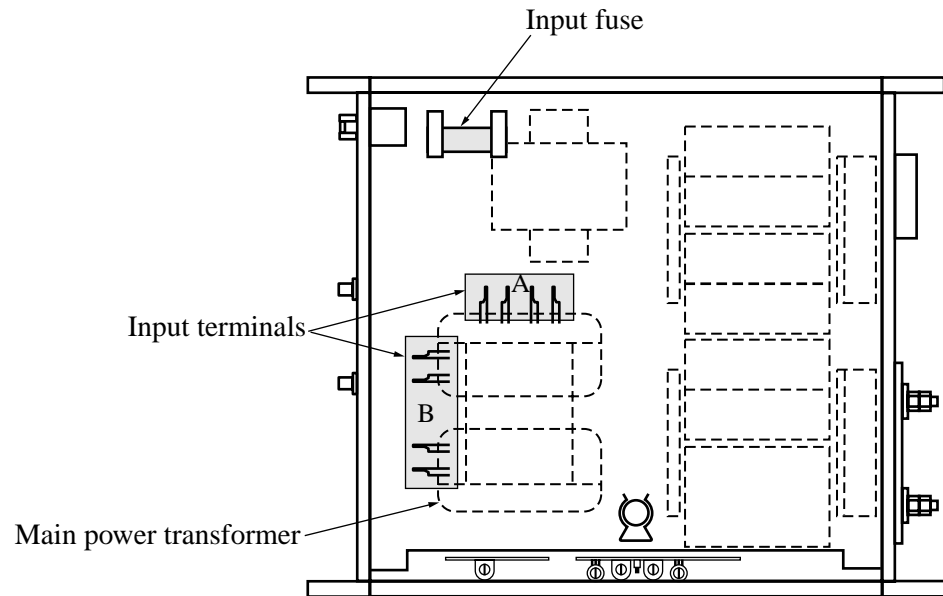

Fig. 1-3 TYPE III model interiors

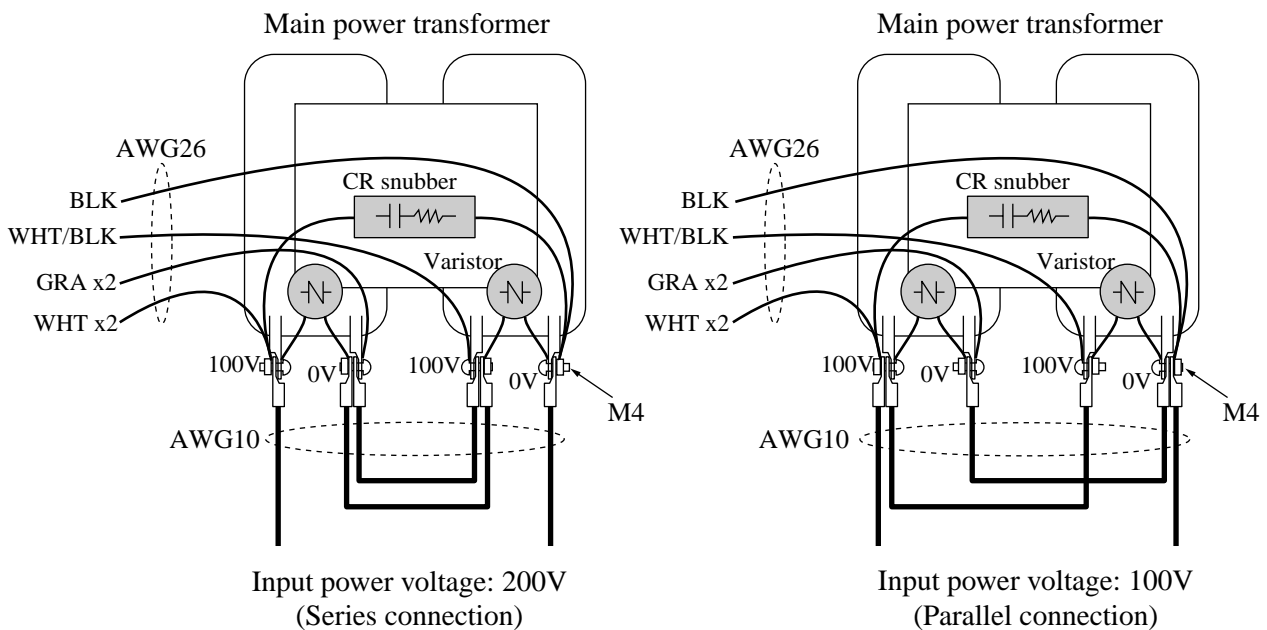

Fig. 1-4 Connections involving the input terminals of the main power transformer



- 
- ⚠ WARNING** • For connections involving the input terminals of the main power transformer, only change those of the AWG10 wiring. Do not modify the AWG26 wiring, CR snubber, or varistor mounting. Modifying the AWG26 wiring connection will destroy internal circuits such as the sub-transformer.
- 

4. Replace the input fuse with a fuse meeting the input power voltage. The input fuse must be rated to handle the input power voltage.

Table 1-2

Input fuse	PAD 16-100L	PAD 35-50L	PAD 35-60L	PAD 60-35L	PAD 110-20L	PAD 250-8L
For 200 V	30 A					
For 100 V	50 A		60 A		50 A	

5. Turn over the input voltage mark-plate on the rear panel.

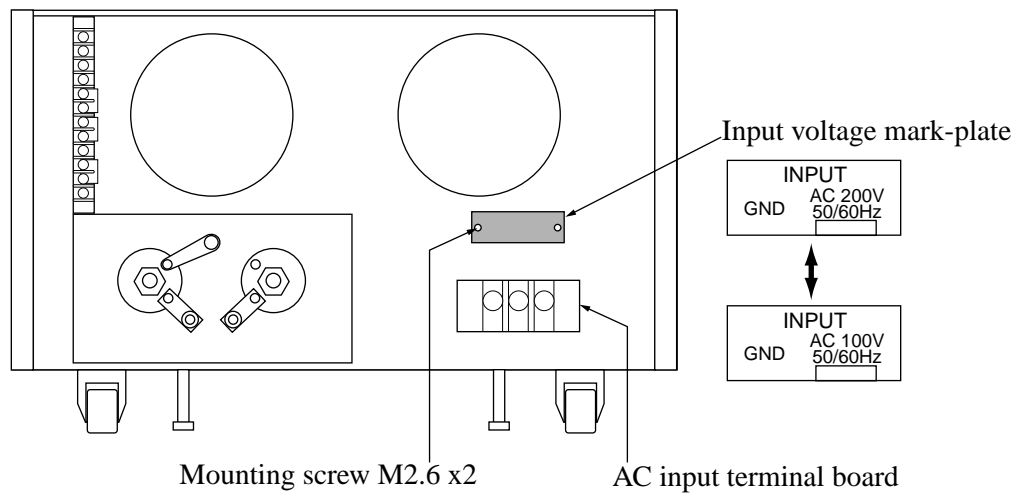

Fig. 1-5 Input voltage mark-plate

6. Replace the top panel.

---

## 1.5 Connecting the AC power cord

Connect the AC power cord to a switchboard sufficiently capable of handling the unit input current, referring to "Power consumption chart" from Chapter 7, "Specifications."

---

**⚠ WARNING**

- **Connection of the AC power cord to the switchboard must be carried out by qualified personnel.**
- **To prevent electric shock, turn off the switch on the switchboard (to cut off the power feed from the switchboard) and then connect the AC power cord.**
- **Install the AC power cord such that the distance between the power supply and the switch on the switchboard is within 3 m. This procedure facilitates operation of the switch on the switchboard in the event of emergency.**

**If the distance to the switch on the switchboard is to be 3 m or more, install the AC power cord with a separate switch provided within 3 m from the power supply. For such a switch, use one with two poles that can be disconnected simultaneously.**

**⚠ CAUTION**

- **Inside the unit, protective circuits including input fuses are connected in order to meet the input terminal rating. Confirm that the wires of the specified color are connected to the corresponding terminals (L, N, and ⊕(GND)). (This connection must be performed by qualified personnel.)**
- 

### Connecting procedure

1. Connect the supplied AC power cord to the AC input terminal board as shown in Fig. 1-6.

---

**⚠ WARNING**

- **For TYPE III model users**

**You cannot use the supplied AC power cord after changing the input power voltage to 100 V. Instead, use a 3-core cabtyre cable with a nominal sectional area of 8 mm<sup>2</sup> or greater. If you cannot obtain such a cable, contact Kikusui distributor/agent.**

**3-core cabtyre cable**

**(8 mm<sup>2</sup>, approximately 4 m) (85-10-0441)**

---

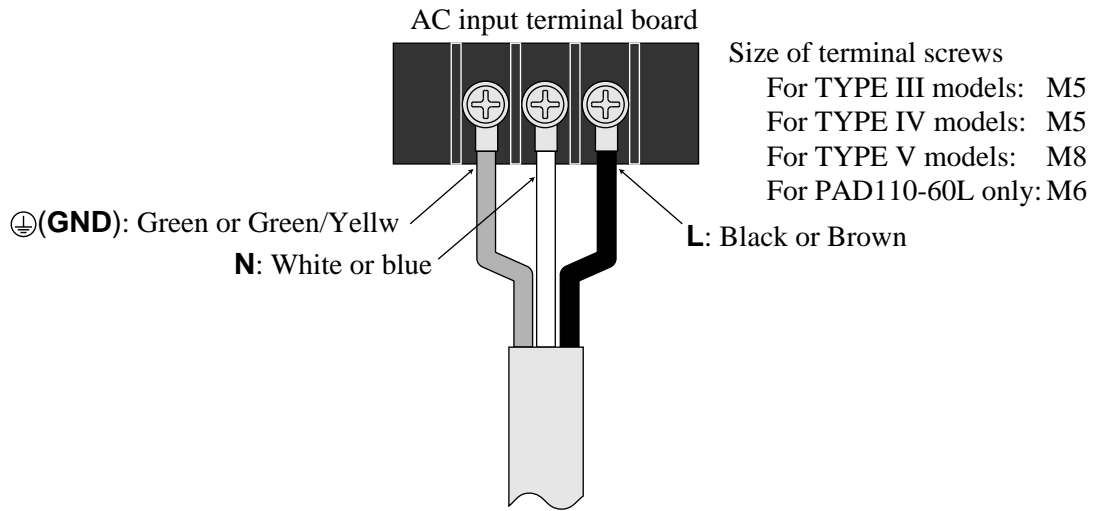

Fig. 1-6 Connection of AC input terminal board

2. Attach crimp terminals to the wires of the AC power cord.

---

**⚠ CAUTION** • Check the terminal screw on the switchboard, and crimp a terminal on each wire end suitable for the said terminal screw. (This connection must be performed by qualified personnel.)

---

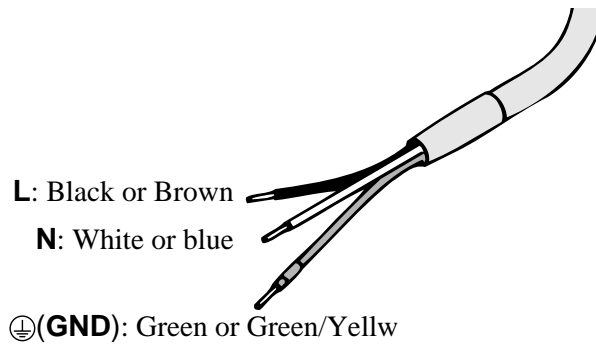

Fig. 1-7 AC power cord (switchboard side)

3. Turn off the switch on the switchboard.  
 4. Connect the AC power cord to the switchboard.

---

## 1.6 Grounding

- 
- ⚠ WARNING**
- Not grounding the power supply creates danger of electric shock.
  - Connect the ground terminal to an electrical ground (safety ground).
- ⚠ CAUTION**
- Not performing adequate grounding work on the power supply results in malfunction or the production of large noises from the power supply.
- 

Securely connect the  $\oplus$ (GND) wire of the AC power cord to the GND terminal of the switchboard.

# 2

## **Chapter 2 Precautions and Preparations for Use**

This chapter contains essential descriptions that must be understood by the user. This chapter must be read thoroughly before operation is begun.

## 2.1 Inrush current

A inrush current may flow when the POWER switch is turned on. See Table 2-1. If you are planning to use several sets of the unit in a system, and to turn on the POWER switches at the same time, check that the AC power source or the switchboard is of sufficient capacity.

Keep 3 seconds or longer interval between ON and OFF of the POWER switch. Repeated ON/OFF at a shorter interval may cause inrush current and shorten the service lives of the input fuse and power switch.

Table 2-1 Inrush current

	TYPE III models	TYPE IV models	TYPE V models
Peak current range	700 A	400 A	600 A
Half-amplitude level	2-5 ms	2-5 ms	2-5 ms

**NOTE**

- The TYPE IV and TYPE V models have a standard built-in inrush current prevention circuit that limits peak current values.

## 2.2 Negative voltage

Turning the CURRENT setting knob to the extreme counterclockwise position produces a negative output voltage of approximately 0.6 V. This voltage causes a reverse current of approximately 10 mA to flow into the load.

If this negative voltage presents a problem, set the unit to constant voltage mode and adjust the offset of the output voltage. For information on adjusting the offset, see "Voltage system adjustment procedure" described in 6.3.4, "Adjustment procedure", in Chapter 6.

## 2.3 Load

Note that the output may become unstable when one of the following loads is connected.

### 2.3.1 When load current has peaks or is pulse-shaped

The current meter on the power supply indicates only mean values. Even when the indicated value is less than the preset current value, therefore, a peak may exceed the preset current value. In such a case, the power supply is instantaneously put into constant-current operation mode, and the output voltage drops accordingly. If you look carefully, you will see the constant current (CC) indicator light up dimly.

For such a load, a larger value should be preset for the constant current, or the current capacity should be increased.

---- Constant current preset value  
..... Meter indication value  
(mean value)

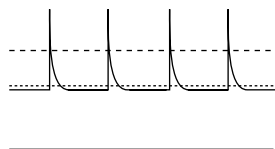

Fig. 2-1 Load current with a peak

---- Constant current preset value  
..... Meter indication value  
(mean value)

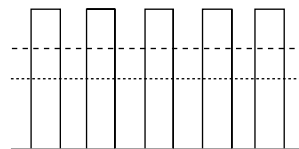

Fig. 2-2 Pulsing load current

## 2.3.2 When a load generates a reverse current to the power supply

The PAD-L series is unable to absorb a reverse current from a load. Therefore, if a power-regenerative load, such as an inverter, converter, or transformer that tends to regenerate power to the power supply, is connected, the output voltage may increase, resulting in unstable output.

To handle this type of load, connect a resistor ( $R_D$ ) to bypass reverse currents, as illustrated in Fig. 2-3. Note that, if such a resistor is used, the current capacity for the load decreases by  $I_{rp}$ .

**CAUTION** • Select  $R_D$  with sufficient rated power. Use of a resistor with insufficient rated power may burn  $R_D$ .

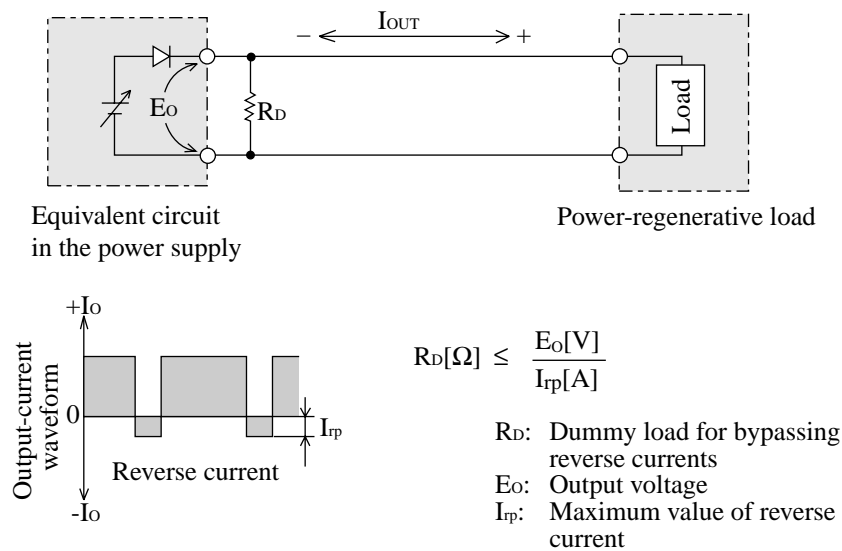

Fig. 2-3 Countermeasure against a power-regenerative load



### 2.3.3 In case of load with accumulated energy, such as batteries

When a load, such as a battery, that contains accumulated energy, is connected, the load can send a large current to the capacitor inside the power supply via the protective diode on the output control circuit inside the power supply. Such currents may damage the internal components of the power supply, and reduce the life of the load.

To handle this type of load, connect in series a diode (DRP) between the power supply and the load for reverse-current prevention.

- 
- ⚠ CAUTION**
- To protect the power supply and the load, select DRP that meets the following requirements:
    1. Reverse-voltage tolerance is at least two times the rated output voltage of the power supply.
    2. Forward current capacity is three to ten times the rated output current of the power supply.
    3. A diode with small loss
  - Be sure to take account of heat generation from DRP. DRP may burn unless adequately dissipated.
  - The remote sensing function cannot be used when the DRP is connected.
- 

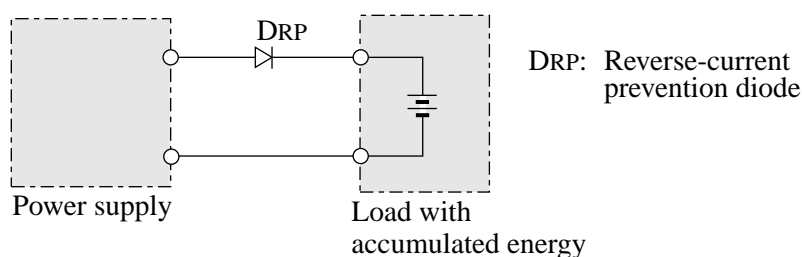

Fig. 2-4 Countermeasure against a load with accumulated energy

## 2.4 Constant-voltage and constant-current power supplies

The PAD-L series is capable of both constant voltage and constant current operation. The following describes these operations.

The ideal constant-voltage power supply has zero output impedance at all frequencies and maintains a definite constant output voltage with respect to variations in load current. The ideal constant-current power supply has infinite output impedance at all frequencies and compensates for load resistance variation by changing the voltage to maintain a constant output current.

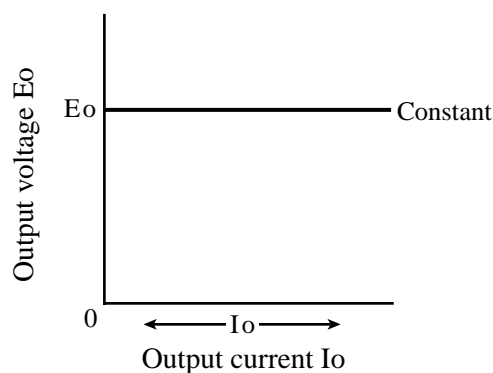

Fig. 2-5 Ideal Constant-Voltage Power Supply

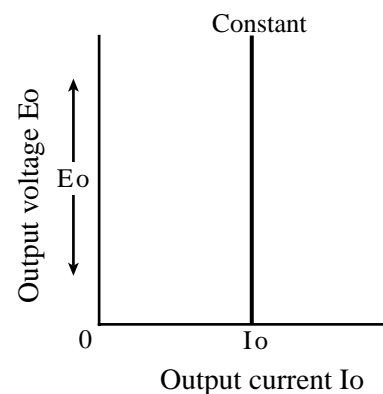

Fig. 2-6 Ideal Constant-Current Power Supply

However, the output impedance of an actual constant-voltage or constant-current power supply is neither zero nor infinite, and they have a definite frequency response. In addition, maximum voltage or maximum current constraints on output are a factor, leaving these power supplies unable to maintain constant voltage or current with respect to all changes in load current or load resistance. The following describes the relationship between the basic operations in constant voltage (CV) and constant current (CC) modes and limit setting of the unit.

The following description assumes a power supply with a DC output of 100 V and 10 A (maximum rated output voltage of 100 V, maximum rated output current of 10 A) as a model.

A resistive load of 10  $\Omega$  is connected to the output terminals of the power supply and the output current limit is set to 5 A. In this condition, output voltage is raised gradually from 0 V. In this case, the power supply operates in the constant voltage (CV) mode. The output current increases as the output voltage increases, and when the output voltage reaches 50 V (that is, the output current has reached 5 A), the output voltage no longer increases beyond 50 V even if you attempt to raise it. This is because the output current is limited to the 5 A set at the beginning of operations, causing the power supply to switch to the constant current (CC) operation mode. In this way, the power supply automatically moves from the constant-voltage to constant-current operation to prevent an overcurrent from flowing. (The point at which the operation modes switch is called the "crossover point"). If the current limit is raised in this condition, the power supply returns to the previous constant voltage

operation, allowing you to increase the output voltage further. If the current limit is increased from 5 A to 9 A in Fig. 2-7, a voltage of up to 90 V can be output.

Next, let's assume a case in which a load resistance of  $4\ \Omega$  is used. The output current limit is regarded as the rated maximum output current. When you increase the output voltage from 0 V, the output current reaches the power supply's maximum current rating when the output voltage reaches 40 V; the power supply cannot output a voltage above 40 V with the maximum current flowing. This is its limit, even though the power supply is not yet generating half its output capacity in terms of power. If you wish to increase the output voltage further, another power supply needs to be connected in parallel to the relevant unit, or the initial unit needs to be replaced by a model having larger current capacity. Particularly for loads into which a transient peak current flows, the current must be set such that its peak does not reach (or exceed) the current limit. If the unit enters constant-current operation mode even when the current is set within the rated output current, the current capacity needs to be raised.

Next, we consider a case of using a load resistance of  $25\ \Omega$ . In this case, when the output current limit is set to 4 A or more, the power supply is capable of outputting voltages from 0 V to the rated maximum output voltage while in constant-voltage operation mode. In this load condition, the output voltage limit is the rated maximum output voltage (for these conditions) and the output current is gradually increased from 0 A. At this time, the power supply is operating in the constant-current (CC) operation mode. The power supply increases the output voltage in order to source the current setting. When the output voltage reaches the supply's maximum rated output of 100 V, no more current can be sourced to this load, regardless of the current setting. If you wish to raise further the current flow in this condition, another power supply needs to be connected in series to the relevant unit or the output voltage needs to be raised. Particularly for loads where a transient surge voltage is generated, the voltage must be set so that the surge voltage does not reach (or exceed) the voltage limit.

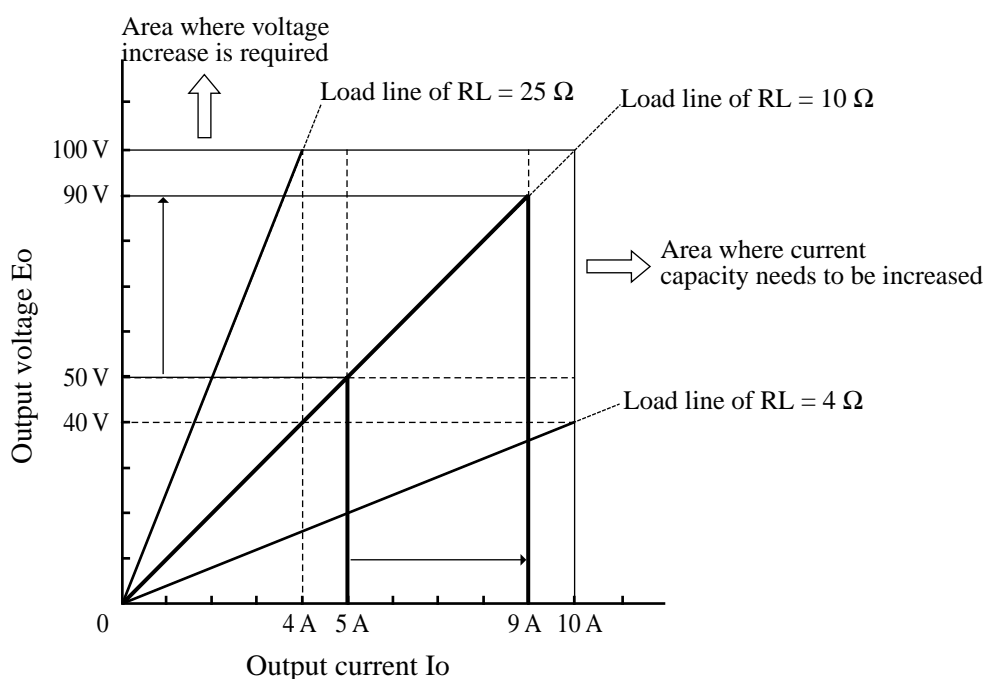

Fig. 2-7 Constant Voltage Operation and Constant Current Operation

## 2.5 Protective circuits

When selecting a regulated power supply, pay attention to important selection standards that differ slightly from those for general instruments that handle electric signals, in addition to the performance required of the power supply. Since a regulated power supply handles power, an accident caused by equipment failure or inadvertent operation will halt the entire system, and damage the power supplies and load. In the worst case, this may lead to a fire.

Because power supplies are required for all electric circuits, electronic circuits, or systems composed of such circuits, reliable operation is critical. The existence of protective circuits that prevent accidents even in the event of a failure is crucial selection standard.

Described below are protective circuits of the PAD-L series.

### **Overvoltage protection circuit**

This feature can be set up from the front panel. It shuts off the POWER switch if the output exceeds a set voltage. The action time is approximately 50 ms.

### **Voltage detection circuit**

If the voltage of the smoothing electrolytic capacitor exceeds the rated voltage due to negligent action such as failing to attach a shorting bar to the rear terminal board or a rectifier circuit failure, this circuit trips instantly to shut off the POWER switch.

### **Current detection circuit**

If the output current becomes excessive due to negligent action such as failing to attach a shorting bar to the rear terminal board or a current limiting circuit failure, this circuit cuts off the control transistor and shuts off the POWER switch or limits the output current to approximately 120% of the rated current.

### **Temperature detection circuit**

This circuit detects the temperature of the cooling package (heat sink) and shuts off the POWER switch if the fins rise above 100 °C due to an increase in ambient temperature or fan stoppage. For TYPE V models, this circuit also shuts off the POWER switch if the core temperature of the main power transformer is 130 °C or more.

### **Inrush current prevention circuit (TYPE IV and TYPE V models only)**

This circuit limits inrush current as follows when the POWER switch is turned on.

TYPE IV models 400 A (peak value) or less

TYPE V models 600 A (peak value) or less

### **Power fuse**

Limits the input current.

This current-limiting fuse has been the type approved by Japanese Industrial Standards (JIS) and complies with the Japanese Electrical Appliance and Material Control Law. It uses a porcelain insulation tube and silicate arc-extinguishing sand and does not produce a flame jet when the circuit is shut off.

### **Output fuse**

Limits the output current.

This current-limiting fuse has been the type approved by JIS and complies with the Japanese Electrical Appliance and Material Control Law. It uses a porcelain insulation tube and silicate arc-extinguishing sand and does not produce a flame jet when the circuit is shut off.

## 2.6 Grounding the output terminal

The output terminals of this unit are isolated from ground. When the GND line of the input power cord is connected to the ground terminal on the switchboard, the unit's chassis assumes a grounding potential, as shown in Fig. 2-8. Cables and loads connected to the output terminals (including the sensing terminal) must be isolated from the chassis with at least the isolation voltage of the unit (\*1, also see Table 2-2). Terminal C and terminals 0 through 6 on the control terminal board on the rear panel will have nearly equal potential on the circuit as the + (pos.) output terminal of the unit. Additionally, terminals 7 and 8 will be at almost the same potential as the + (pos.) terminal on the rectification smoothing capacitor of the unit (\*2). Accordingly, cables and devices connected to these terminals must be isolated with at least the isolation voltage of the unit.

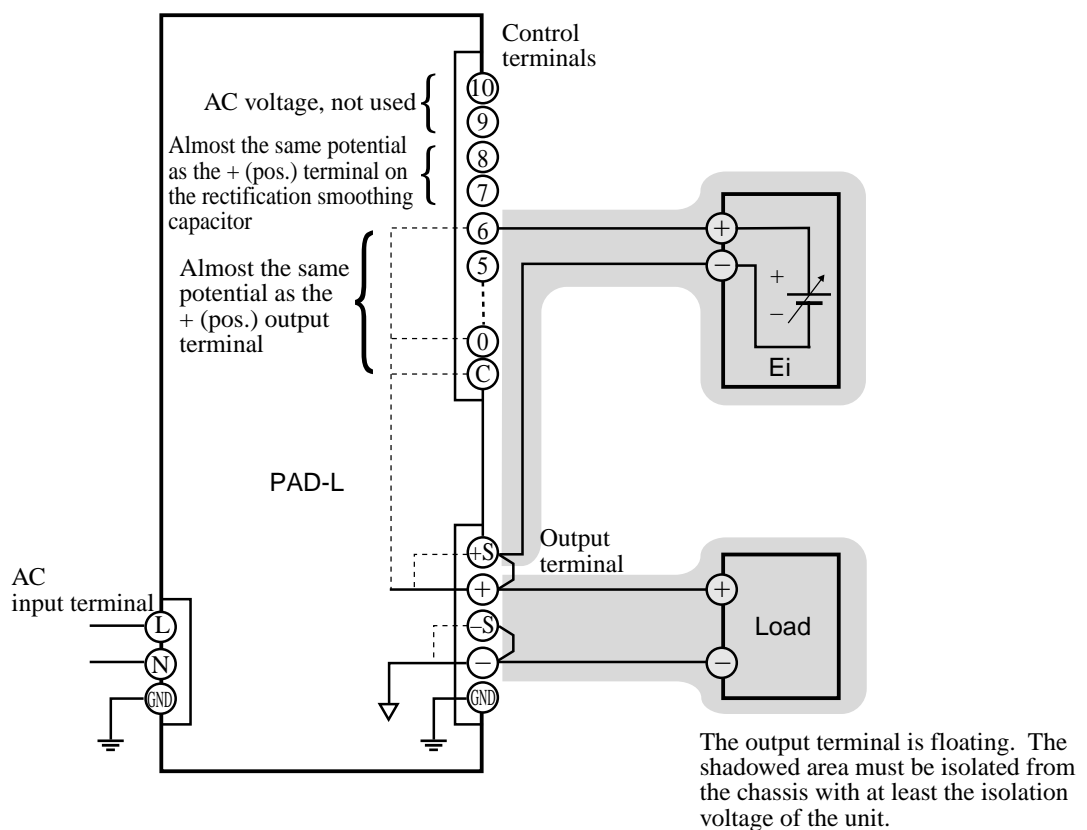

Fig. 2-8 Without grounding the output terminal

- DESCRIPTION**
- \*1 Isolation voltage: The maximum external voltage that may be applied between an output terminal on the power supply and ground (chassis).
  - \*2 Rectification smoothing capacitor: A large capacitor used to smooth secondary outputs (rectified sine waves) from the main power transformer that have been rectified by a diode. The as-yet unstabilized voltage between the capacitor terminals is greater than the output voltage.

## Grounding the output terminal (continued)

The procedure for grounding the output terminal is illustrated below.

Fig. 2-9 illustrates a connection of the - (neg.) output terminal to the GND (chassis ground) terminal. In this case, the - (neg.) output terminal is at grounding potential. For this reason, cables and loads connected to output terminals (including the sensing terminal) need to be isolated from the chassis with at least the maximum unit output voltage. The same applies to cables and devices connected to terminal C and terminals 0 through 6 on the control terminal board. Note that cables and devices connected to terminals 7 and 8 need to be isolated with at least twice the maximum unit output voltage. This is because these terminals are at almost the same potential as the + (pos.) terminal of the rectification smoothing capacitor.

When the + (pos.) output terminal is connected to the chassis ground terminal, the + (pos.) output terminal is at grounding potential. As a result, negative (minus) outputs are made to the chassis. As in the preceding case, cables and loads connected to the output terminal must be isolated from the chassis with at least the maximum unit output voltage. Cables and devices connected to terminals C through 6 are at almost the same potential as the chassis. However, they need to be isolated from the - (neg.) output terminal with at least the maximum unit output voltage. As mentioned previously, cables and devices connected to terminals 7 and 8 need to be isolated with at least twice the maximum unit output voltage.

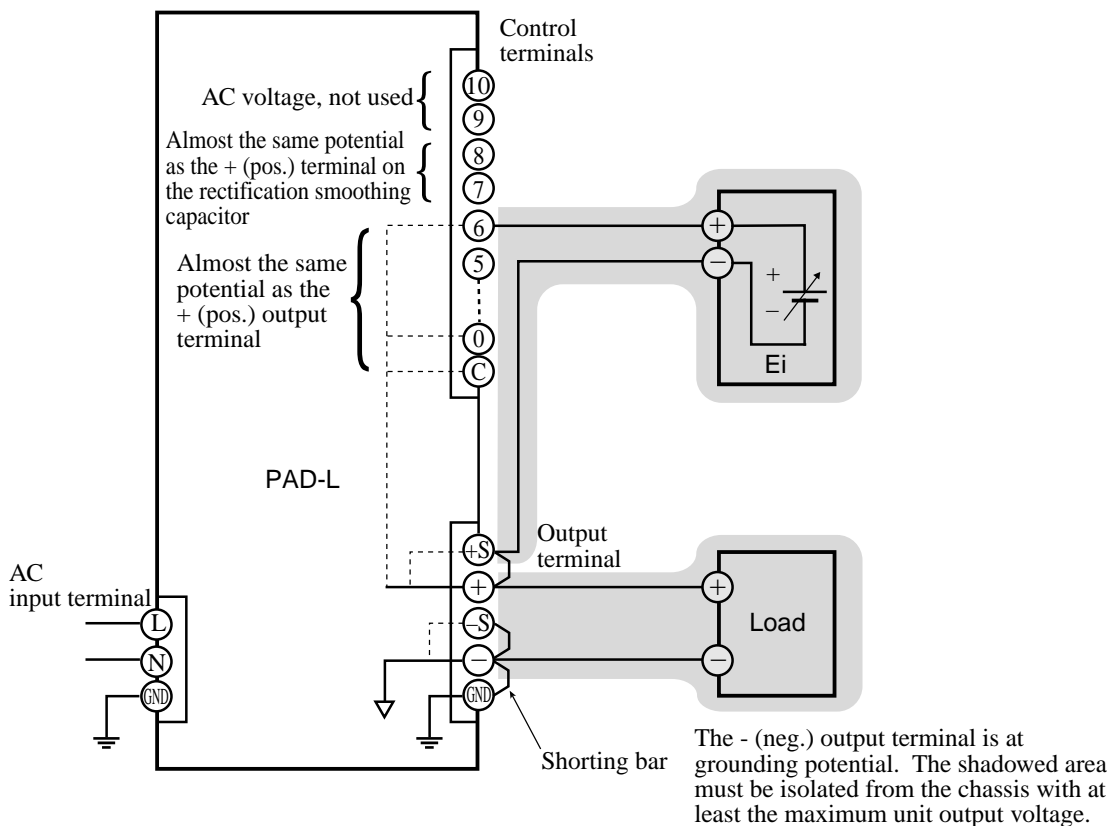

Fig. 2-9 Grounding the - (neg.) terminals

In conclusion, if there is no need to float the output terminals, ensure safety by connecting either of the output terminals to the chassis ground terminal. Otherwise, outputs may suffer larger ripples. The PAD-L series's specifications are based on the assumption that the - (neg.) terminal is connected to the chassis ground terminal.

- 
- ⚠ WARNING**
- **When grounding the output terminal, make connections securely using the accompanying shorting bar.**
  - **Even if the output terminal is grounded, it is necessary to isolate the output terminals (including the sensing terminal) and terminals C through 8 on the control terminal board with at least the isolation voltage of the unit.**  
**Incomplete connection of the shorting bar may result in electric shock and output short-circuits unless full isolation is provided with at least the isolation voltage of the unit.**  
**If no cable with the rated voltage is available, ensure the necessary withstand voltage through measures such as installing a cable in an insulating tube that can withstand the unit isolation voltage or more.**
  - **When remote-controlling the unit using an external voltage source (Ei), float Ei outputs instead of grounding them (floating). As in the example shown in Fig. 2-9, grounding Ei outputs may lead to output short-circuits.**
- 

Table 2-2 Isolation voltage value

Type III	PAD 16-100L	PAD 35-50L	PAD 35-60L	PAD 60-35L	PAD 110-20L	PAD 250-8L
Isolation voltage	± 250 V	± 250 V	± 250 V	± 250 V	± 250 V	± 500 V
Type IV	PAD 35-100L	PAD 60-60L	PAD 110-30L	PAD 250-15L		
Isolation voltage	± 250 V	± 250 V	± 250 V	± 500 V		
Type V	PAD 35-200L	PAD 60-120L	PAD 110-60L			
Isolation voltage	± 250 V	± 250 V	± 250 V			





# 3

## Chapter 3 Basic Operation

This chapter explains the basic operations of the front panel.

## 3.1 Turning on the power

In this section, the POWER switch is turned ON without a load to check the unit operating conditions.

- 
- ⚠ CAUTION**
- **Actual power is output during this procedure; do not attach a load to the output terminals.**
  - **To avoid overheating and damage to the internal circuits, leave terminals 9 and 10 of the control terminal board free. AC voltage will be output to those terminals.**
- 

### Turning on the power procedure

1. Check that the POWER switch is turned off.
2. Make sure the AC power cord is connected properly.
3. Make sure nothing is connected to the output terminals.
4. Check the connections of the shorting bars at the output terminals.  
Check that the sensing terminals are connected to the output terminals and that the GND terminal is securely connected to the - (neg.) output terminal. See Fig. 3-1.
5. Check the connections of the shorting bars at the control terminal board.  
Check that terminals 0 and 1, terminals 3 and 4, and terminals 5 and 6 are securely connected. See Fig. 3-2.
6. Turn on the switch on the switchboard.
7. Turn the VOLTAGE setting knob fully counterclockwise.
8. Turn the CURRENT setting knob fully clockwise.
9. Turn on the POWER switch.
10. Check that the POWER indication lamp and C.V lamp are functional.
11. Turn the VOLTAGE setting knob clockwise so that the voltmeter indicates the rated output voltage.

- 
- NOTE**
- If the OVP trip point is set to a level less than the rated output voltage, the POWER switch is turned off. For information on OVP, see 3.2.1 "OVP (Overvoltage protection) trip point presetting".
- 

12. Check that the ammeter pointer swings past the rated output current when the CURRENT/VOLT. LIMIT switch is pressed.
13. Turn the CURRENT setting knob to the extreme counterclockwise position to confirm that the C.C lamp lights.
14. Check that the voltmeter indicates the rated output voltage when the CURRENT/VOLT. LIMIT switch is pressed.

15. Turn the VOLTAGE setting knob fully counterclockwise.
16. Turn the CURRENT setting knob fully clockwise.
17. Turn off the POWER switch.

This concludes the operating conditions inspection.

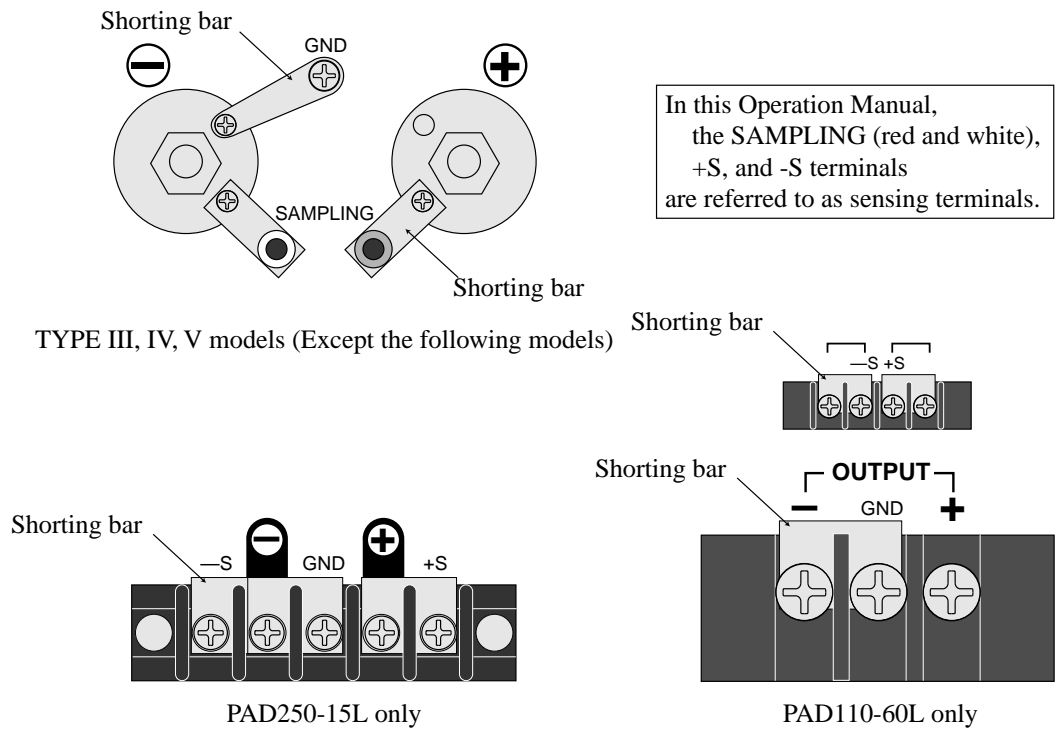

Fig. 3-1 Output terminals (Shorting bars connection at factory shipment)

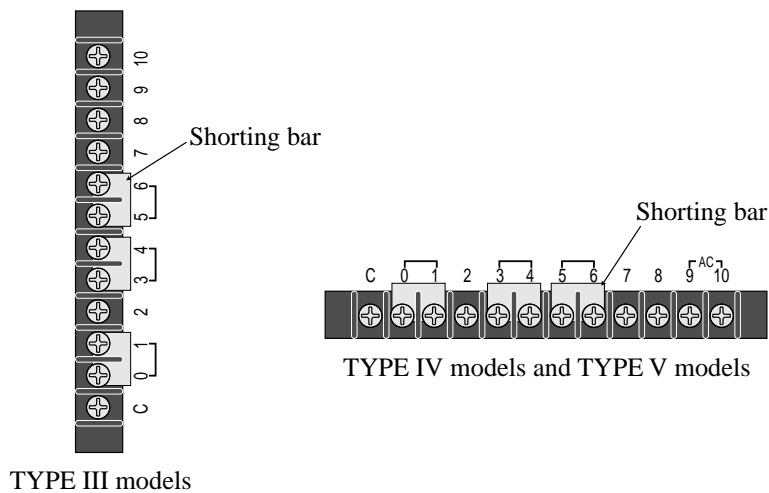

Fig. 3-2 Control terminal board (Shorting bars connection at factory shipment)

---

## 3.2 Basic operation

There are two different modes for the unit: constant voltage (CV) mode, and the constant current (CC) mode. Before starting to use the unit, determine which mode is to be employed, and select the procedure suitable for the selected operation mode.

---

**⚠ CAUTION** • To protect the load, preset the OVP trip point for either operation mode.

---

### 3.2.1 OVP (OverVoltage Protection) trip point presetting

The overvoltage protection (OVP) function protects a load from unexpectedly high voltage. If the OVP function is activated, the POWER switch is turned off. To turn on the POWER switch again, wait for at least 60 seconds, then turn on the POWER switch. In this case, lower the output voltage preset value. Otherwise, the OVP function is reactivated when the POWER switch is turned on.

---

**⚠ CAUTION** • The OVP trip point is factory-preset to approx. 110% of the rated output voltage of the unit. When using the unit, preset to an OVP trip point suitable for the load.

---

**NOTE** • To turn on the POWER switch again after OVP has been activated, wait for at least 60 seconds after cutting off the output, then turn on the POWER switch. Otherwise, the output cutoff circuit may remain latched, disabling the output.

---

### OVP trip point presetting for TYPE III and TYPE IV models

---

**⚠ CAUTION** • For TYPE III and TYPE IV models, the OVP trip point voltage is output to preset the OVP trip point. Remove any load that has been connected. After presetting the OVP trip point, always check that the OVP trips at the set voltage.

---

1. Check that nothing is connected to the unit output terminals.
2. Use a slotted head screwdriver to turn the O.V.P variable resistor to the extreme clockwise position.
3. Turn the CURRENT setting knob clockwise.  
Turning it slightly is sufficient, since no current flows at no load.
4. Turn on the POWER switch.

- 
5. Use the VOLTAGE setting knob to set a value for overvoltage to protect the unit.
  6. Slowly turn the O.V.P variable resistor counterclockwise and stop it when the POWER switch turns off.
  7. Turn the VOLTAGE setting knob counterclockwise to lower the output set voltage.
  8. Wait approximately 60 seconds, then turn on the POWER switch.
  9. Slowly turn the VOLTAGE setting knob clockwise and check that the POWER switch is turned OFF when the output voltage reaches the set OVP voltage.
  10. Turn the VOLTAGE setting knob counterclockwise to lower the output set voltage.

## OVP trip point presetting for TYPE V model

- 
-  **CAUTION** • The OVP trip point of the TYPE V model can be preset without outputting an actual voltage. However, to ensure safety, always check that the OVP trips at the set voltage after setting the OVP trip point.
- To check that the OVP trips, an actual voltage must be output; disconnect any load that may be connected.**
- 

1. Check that nothing is connected to the unit output terminals.
2. Use a slotted head screwdriver to turn the O.V.P variable resistor to the extreme clockwise position.
3. Turn the CURRENT setting knob clockwise.  
Turning it slightly is sufficient, since no current flows at no load.
4. Turn the VOLTAGE setting knob counterclockwise.
5. Turn on the POWER switch.
6. Turn the O.V.P variable resistor while holding down the O.V.P PRESET switch to set a value for overvoltage to protect the unit.
7. Slowly turn the VOLTAGE setting knob clockwise and check that the POWER switch is turned OFF when the output voltage reaches the set OVP voltage.
8. Turn the VOLTAGE setting knob counterclockwise to lower the output set voltage.

---

## 3.2.2 Using as a constant voltage power supply

---

**⚠ CAUTION** • A current limit value and required voltage value must be preset to use the unit as a constant voltage power supply. To preset these values, an actual voltage must be output; disconnect any load that may be connected.

---

1. Turn on the POWER switch.
2. Make sure the C.V or C.C lamp lights up.
3. While pressing the CURRENT/VOLT. LIMIT switch, set a current value that can be applied to the load by turning the CURRENT setting knob.  
The value set here is used as a current-limiting value.  
The CURRENT/VOLT. LIMIT switch simply displays the present voltage and current settings. It has no memory feature.
4. Set the requested voltage by turning the VOLTAGE setting knob.
5. Turn off the POWER switch.
6. Connect a load to the output terminals.
7. Turn on the POWER switch.
8. The C.V lamp lights up to indicate that the unit is in constant voltage mode.

---

**⚠ CAUTION** • For the loads listed below in which sudden voltage application is undesirable, follow steps 1 to 3 above, then follow steps 4 to 9 below.

- a. Loads of unknown resistance
- b. Loads whose resistance varies over a wide range
- c. Loads of large inductance

---

4. Turn the VOLTAGE setting knob fully counterclockwise.
5. Turn off the POWER switch.
6. Connect a load to the output terminals.
7. Turn on the POWER switch.
8. Turn the VOLTAGE setting knob slowly counterclockwise to raise voltage gradually.
9. The C.V lamp lights up to indicate that the unit is in constant voltage mode.

---

### 3.2.3 Using as a constant current power supply

- 
- ⚠ CAUTION** • A voltage limit value and required current value must be preset to use the unit as a constant current power supply. To preset these values, an actual voltage must be output; disconnect any load that may be connected.
- 

1. Turn on the POWER switch.
2. Make sure the C.V or C.C lamp lights up.
3. Set the voltage value to be applied to the load by turning the VOLTAGE setting knob.  
The value set here is used as a voltage-limiting value.
4. While pressing the CURRENT/VOLT. LIMIT switch, set the requested current by turning the CURRENT setting knob.  
The CURRENT/VOLT. LIMIT switch simply displays the present voltage and current settings. It has no memory feature.
5. Turn off the POWER switch.
6. Connect a load to the output terminals.
7. Turn on the POWER switch.
8. The C.C lamp lights up to indicate that the unit is in constant current mode.

- 
- NOTE** • If the CURRENT/VOLT. LIMIT switch is pressed during constant current operations, the output current drops from the set value by approximately 2 mA maximum.
- 

- ⚠ CAUTION** • For the loads listed below in which sudden current application is undesirable, follow steps 1 to 3 above, then follow steps 4 to 9 below.
- a. Loads of unknown resistance
  - b. Loads whose resistance varies over a wide range
  - c. Loads of large inductance
- 

4. Turn the CURRENT setting knob fully counterclockwise.
5. Turn off the POWER switch.
6. Connect a load to the output terminals.
7. Turn on the POWER switch.
8. Turn the CURRENT setting knob slowly counterclockwise to increase current gradually.
9. The C.C lamp lights up to indicate that the unit is in constant current mode.

## 3.3 Connecting load

This section describes the cables (load cables) connecting the unit and a load and the proper procedure for connecting loads to the output terminals.

### 3.3.1 load cables

- 
- ⚠ WARNING** • For load cables, use cables that have sufficient current capacity with respect to the rated output current of the unit and that have sufficient withstand voltage with respect to the isolation voltage of the unit.
- 

#### Current capacity of load cables

Load cables must be rated to carry the maximum rated output current of the unit. If their current rating exceeds the maximum rated output current, they will carry the maximum current even if a load is short circuited.

The allowable current of a wire is determined by the maximum allowable temperature of the cable insulation, which in turn is governed by a current-caused resistance loss, ambient temperature, and thermal resistance to the outside. The allowable currents in Table 3-1 show the capacity of current flowing through a heat-resistant PVC wire (single wire) having a maximum allowable temperature of 60 °C when the wire is stretched horizontally in the air at an ambient temperature of 30 °C. If the condition is such that PVC wires with lower heat-resistant temperature are used, ambient temperature reaches more than 30 °C, or the wires are bundled, resulting in low heat radiation, the current capacity needs to be reduced.

Based on this consideration, it is better to make heat radiation as great as possible to let a larger current flow, as long as wires having the same heat-resistant temperature are used. For measures against noise in the load cables, installing the + (pos.) and - (neg.) output lines side by side or bundling them together is more effective against unnecessary noise. The Kikusui-recommended currents shown in Table 3-1 are allowable current values that have been reduced in consideration of potential bundling of load cables. Use these values as a guideline when installing load wires.

Because wires have resistance, voltage drop in wires becomes greater as the wire becomes longer or the current becomes larger. This causes the voltage applied at the load end to be smaller. The PAD-L series power supplies have a sensing function that compensates for this voltage drop. Compensation of up to approximately 1.2 V is available for a single line. If voltage drop exceeds this level, wires having a greater sectional area should be used.



Table 3-1 Nominal Cross-sectional Areas of Cables and Allowable Currents

Nominal cross-sectional area [mm <sup>2</sup> ]	AWG	(Reference cross-sectional area) [mm <sup>2</sup> ]	Allowable current (*) [A] (Ta = 30 °C)	Current recommended by Kikusui [A]
2	14	(2.08)	27	10
3.5	12	(3.31)	37	-
5.5	10	(5.26)	49	20
8	8	(8.37)	61	30
14	5	(13.3)	88	50
22	3	(21.15)	115	80
30	2	(33.62)	139	-
38	1	(42.41)	162	100
50	1/0	(53.49)	190	-
60	2/0	(67.43)	217	-
80	3/0	(85.01)	257	200
100	4/0	(107.2)	298	-
125	-	-	344	-
150	-	-	395	300
200	-	-	469	-

\*: Excerpts from Japanese laws related electrical equipment

### Withstand voltage of load cables

For load cables, use cable with a higher voltage rating than the isolation voltage of the unit. For more information, see 2.6 "Grounding the output terminal".

### 3.3.2 Connection to the output terminals

- 
- ⚠ WARNING**
- To avoid electric shock, turn off the **POWER** switch when connecting the load.
  - After connecting the load cable, mount the output terminal cover.
- ⚠ CAUTION**
- To assure a good connection of the load cable to the output terminals, use crimped terminals.
- 

In general, the chassis ground terminal should be connected to the + (pos.) or - (neg.) terminal using a supplied shorting bar. Otherwise, outputs may suffer larger ripples. The PAD-L series's specifications are based on the assumption that the - (neg.) terminal is connected to the chassis ground terminal. For details, see 2.6 "Grounding the output terminal".

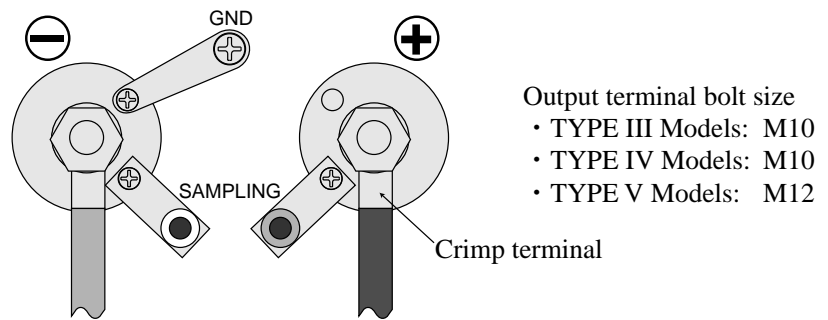

TYPE III, IV, V models (Except the following models)

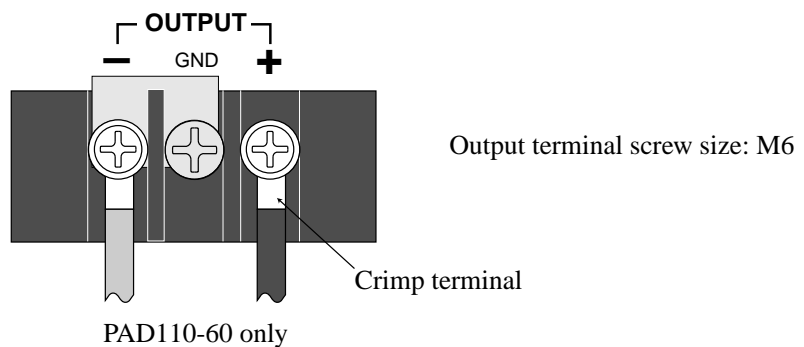
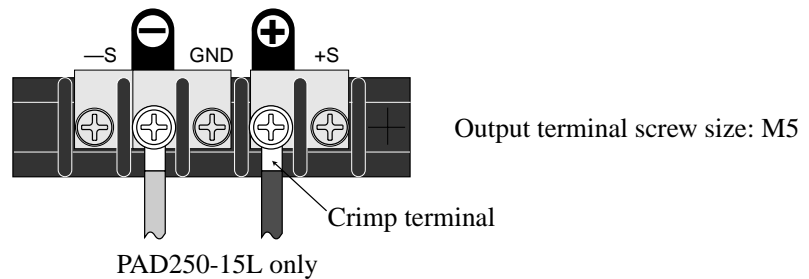

Fig. 3-3 Connection to the output terminals

## 3.4 Using the guard cap(s)

The unit includes VOLTAGE and CURRENT setting knobs; in order to make them mechanically fixed or semi-fixed, guard caps are supplied with the unit. Use them if output presetting is seldom necessary.

---

**NOTE**

- For the following models, the CURRENT setting knob is of the double-piece type; the guard caps cannot be used.

PAD16-100L

All TYPE IV models

All TYPE V models

- If you intend to reinstall the knob, keep it in a safe place.
- 

### Mounting procedure

1. Turn on the POWER switch.
2. While pressing the CURRENT/VOLT. LIMIT switch, set the output level to a desired value. Here, a rough presetting is acceptable.
3. Use the supplied allen wrench to remove an output setting knob that is to be replaced with a guard cap.
4. While pressing the CURRENT/VOLT. LIMIT switch, set the output level to a desired value by using a slotted-head screwdriver.

- **To fix presetting**

5. Mount the guard cap, instead of the removed knob.
6. Press the CURRENT/VOLT. LIMIT switch again to confirm the presetting is not changed.

- **To semi-fix presetting**

5. As shown in Fig. 3-4, pierce the guard cap top with a phillips-head screwdriver.
6. Mount the guard cap, instead of the removed knob.  
Since the guard cap is pierced, the output level may be readjusted using a slotted-head screwdriver.

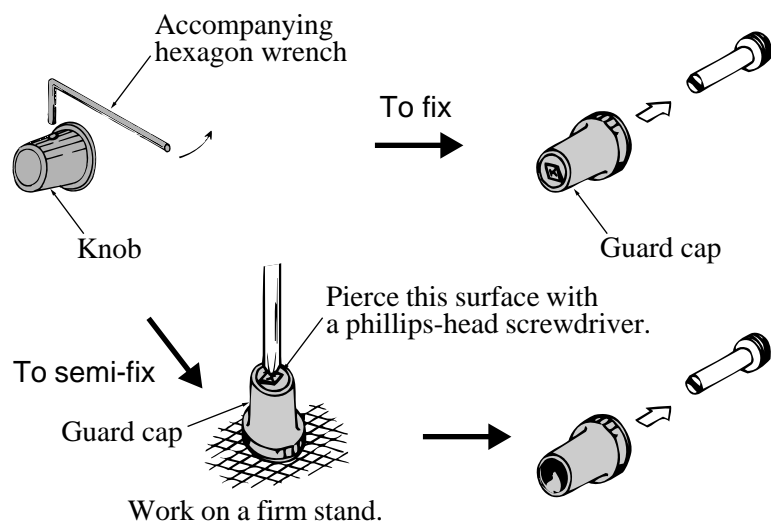

Fig. 3-4 Mounting the guard cap

# 4

## Chapter 4 Applied Operation

Use of the control terminal board on the rear panel allows the unit to perform remote sensing, external output control, parallel operation, and series operation.

## 4.1 Remote sensing

The remote sensing function is intended to reduce the influence of voltage drops affected by the load cable resistance, to keep the output voltage stable at the load terminal. The PAD-L series' remote sensing function is capable of compensating for up to approximately 1.2 V for a single line. Select load cables with sufficient current capacity so that a voltage drop in the load cables does not exceed the compensation voltage.

To perform remote sensing, an electrolytic capacitor is needed at the sensing point (load terminal).

---

**NOTE**

- A voltage drop that can be compensated for is approximately 1.2 V for a single line. When remote sensing is carried out at the rated output voltage, the unit's output is limited by the maximum voltage. Thus, in the event of a voltage drop of 0.3 V or greater, the rated output voltage cannot be compensated for at the load ends. In this case, use wires with larger sectional areas to reduce the voltage drop below 0.3 V.
- 

### Connecting procedure

1. Turn off the POWER switch.
2. As shown in Fig. 4-1, remove the sensing shorting bar.
3. Install sensing wires between the sensing terminals (+S and -S terminals or SAMPLING terminals) and the load ends, as shown in Fig. 4-1.

To decrease output ripple voltages resulting from inductive effects, use a 2-core shielded wire for the sensing. Connect the shield to the + (pos.) terminal.

---

**⚠ WARNING**

- **For sensing wires, use cable with a higher voltage rating than the isolation voltage of the unit. For more information, see 2.6 "Grounding the output terminal".**

**Protect the uncovered part of the cable with an insulation tube of at least the isolation voltage of the unit.**

**⚠ CAUTION**

- **If the sensing wire is disconnected, the output voltage at the load terminals cannot be stabilized, and excessive voltage may be applied to the load. Use crimp terminals for secure connections.**
  - **To turn on/off the power supplied to a load using a mechanical switch, provide additional switches between the sensing wires as shown in Fig. 4-2; turn on/off the power and remote sensing function simultaneously.**
- 

4. Connect electrolytic capacitors (C1 and C2) between the output terminals and sensing terminals.

5. Connect an electrolytic capacitor (C) with a capacity of approx. 100 to 100,000  $\mu$  F across the load terminals.

**⚠ CAUTION** • Use a capacitor (C) whose withstand voltage is 120% or more of the unit's rated voltage.

- NOTE**
- If the length of wiring to a load extends to 3 m or more, the phase shift caused by the inductance and capacitance of the wiring becomes non-negligible, thereby causing oscillation. In such cases, the capacitor (C) prevents oscillation.
  - If the load current changes suddenly to pulse form, the output voltage may increase due to effects from the inductance components of the wiring. In such cases, the capacitor (C) also prevents variations in output.

6. Recheck that the connections.

**⚠ WARNING** • After connections are complete, install the output terminal cover.

**⚠ CAUTION** • After using remote sensing, disconnect the sensing wires and reinstall the shorting bars for remote sensing between the output terminals and sensing terminals.

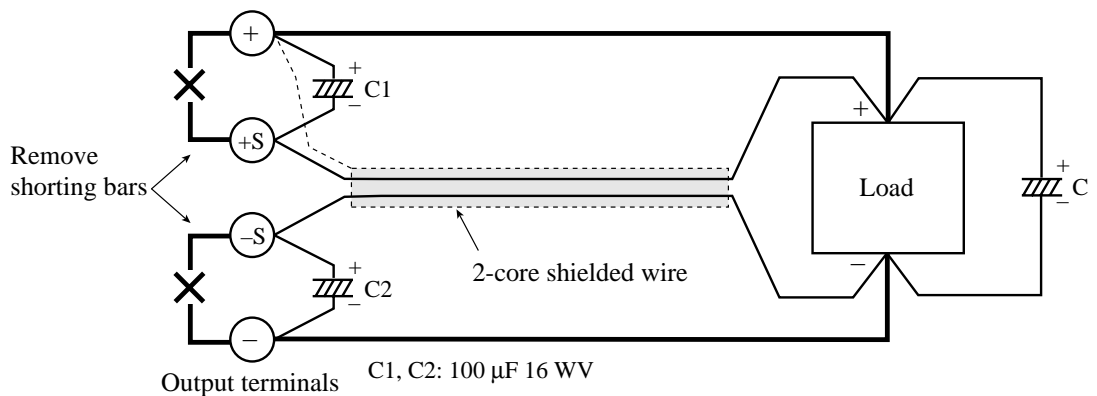

Fig. 4-1 Remote sensing connection

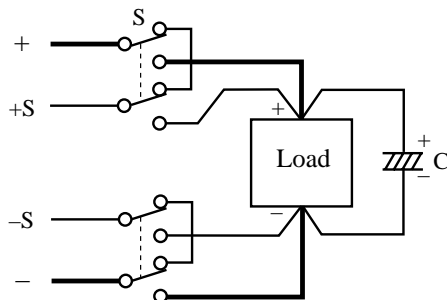

Fig. 4-2 Power on/off using mechanical switches

## 4.2 CV mode by remote control

### 4.2.1 Output voltage control (I) with external resistor

- This method is capable of generating output voltage proportional to the resistance of an external resistor.
- The resolution of the output voltage is determined by an external resistor; any desired resolution is obtained.

#### Connecting and setting procedure

1. Turn off the POWER switch.
2. As shown in Fig. 4-3, remove the shorting bar across the control terminals 3 and 4.
3. Connect an external resistor (R1) across the control terminals 4 and 5 as shown in Fig. 4-3.

---

**⚠ WARNING**

- **Isolate the external resistor (R1) and the cable connected to it with at least the isolation voltage of the unit. For details, see 2.6 "Grounding the output terminal."**
- **When using a shielded cable for the connection, protect the uncovered part of the cable with an insulation tube of at least the isolation voltage of the unit.**

**⚠ CAUTION**

- **If R1 is disconnected, excessive voltage may be applied to a load. To assure a good connection, use crimped terminals.**
- **To use R1 which consists of a multiple number of fixed resistors and a switch, and select one of them for control, use a short circuit type or continuous type switch.**

---

**NOTE**

- To reduce the effects of noise on output, use a 2-core shielded wire or a twisted-pair wire to connect to terminals, making them as short as possible. Longer wiring results in greater susceptibility to the effects of noise, and use of cables with antinoise measures may not solve the problem, resulting in improper operation.  
When using a shielded wire, connect the shield to the + (pos.) output terminal.
  - Approx. 1 mA of current always flows in R1. For R1, use a 1/2 W or larger resistor with a good temperature coefficient and small aging effect such as metal film or wire-wound type resistor.
-



4. Recheck that the connections.

**⚠ WARNING** • After connections are complete, install the terminal cover.

5. Turn on the POWER switch.

6. Adjust the  $V_{os}$  variable resistor on the front panel so that the output voltage becomes 0 V when  $R_1$  is zero.

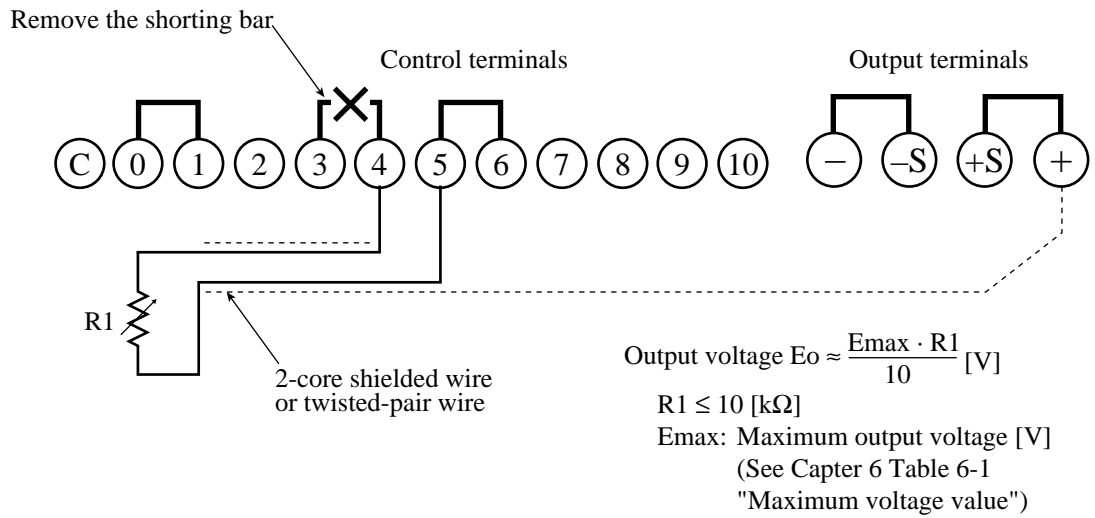

Fig. 4-3 Connections for output voltage control (I) with external resistor

## 4.2.2 Output voltage control (II) with external resistor

- This voltage control is a fail-safe system in which no overshoot occurs when switching a resistance value.
- The output voltage  $E_o$  and resistance value  $R_2$  are inversely proportional, as shown in Fig. 4-4. If the circuit opens when switching the resistor or due to an accident, the resistance value become  $\infty$  (infinite) and output becomes zero.
- The output voltage  $E_o$  is determined by  $R_2$  and  $E_{ref}$ , according to the equation shown in Fig. 4-5.  $E_{ref}$  is set with the VOLTAGE setting knob on the front panel. (Use a guard cap (supplied) to disable a setting knob on the panel.)
- The advantage of this applied operation is a fail-safe system in which the output voltage decreases if the circuit becomes open. The drawback is that it is impractical when a low voltage is programmed, since a very high resistance value is required. In real-world applications, 0 to 200 k $\Omega$  variable resistors are suitable. (In general, high resistance requires greater attention to temperature coefficient and noise.)

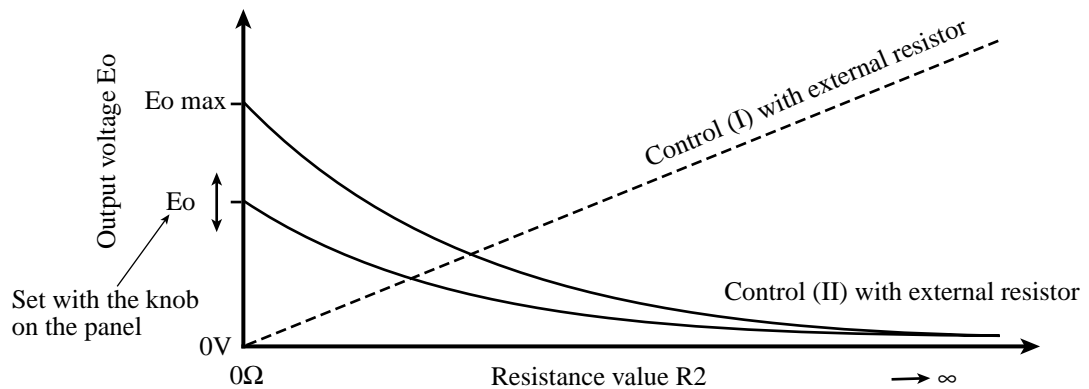

Fig. 4-4 Control (I) and control (II) with external resistor

---

## Connecting procedure

1. Turn off the POWER switch.
2. As shown in Fig. 4-5, remove the shorting bar across the control terminals 5 and 6.
3. Connect an external resistor (R2) across the control terminals 5 and 6 as shown in Fig. 4-5.

- 
- ⚠ WARNING**
- Isolate the external resistor (R2) and the cable connected to it with at least the isolation voltage of the unit. For details, see "2.6 Grounding the output terminal."
  - When using a shielded cable for the connection, protect the uncovered part of the cable with an insulation tube of at least the isolation voltage of the unit.

- ⚠ CAUTION**
- If R2 is disconnected, an unexpected voltage may be supplied by external noise. To assure a good connection, use crimped terminals.

- 
- NOTE**
- To reduce the effects of noise on output, use a 2-core shielded wire or a twisted-pair wire to connect to terminals, making them as short as possible. Longer wiring results in greater susceptibility to the effects of noise, and use of cables with antinoise measures may not solve the problem, resulting in improper operation. When using a shielded wire, connect the shield to the + (pos.) output terminal.

- 
4. Recheck that the connections.

- 
- ⚠ WARNING**
- After connections are complete, install the terminal cover.
-

## Output voltage control (II) with external resistor (continued)

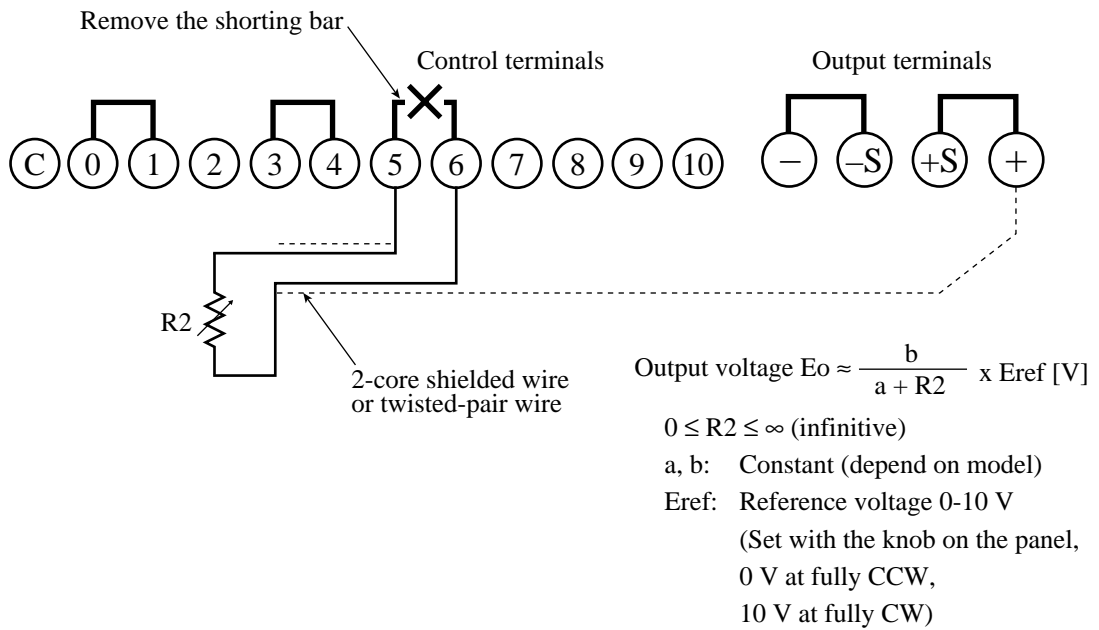

Fig. 4-5 Connections for output voltage control (II) with external resistor

Table 4-1 Constant (depend on model)

Type III	PAD 16-100L	PAD 35-50L	PAD 35-60L	PAD 60-35L	PAD 110-20L	PAD 250-8L
Type IV	-	PAD 35-100L	-	PAD 60-60L	PAD 110-30L	PAD 250-15L
Type V	-	PAD 35-200L	-	PAD 60-120L	PAD 110-60L	-
a [k ]	3.3	3.4	3.4	5	9.8	9.9
b [k ]	5.2	12	12	30	108	248

---

## 4.2.3 Output voltage control with external voltage

This method is used to control output voltage using 0- approx. 10 V.

---

**NOTE**

- When controlling the unit using an external voltage source which has a quick rising time relative to the capacitive load, the phase control circuit of the unit cannot respond to the external voltage, which may cause AC components to be superimposed on the rising waveform.
- 

### Connecting procedure

1. Turn off the POWER switch.
2. As shown in Fig. 4-6, remove the shorting bar across the control terminals 5 and 6.
3. Connect an external source (Ei) across the control terminal 6 and +S terminal as shown in Fig. 4-6.

---

**⚠ WARNING**

- Isolate the external voltage source (Ei) and the cable connected to it with at least the isolation voltage of the unit. Float Ei outputs instead of grounding them (floating). For details, see 2.6 "Grounding the output terminal."
- When using a shielded cable for the connection, protect the uncovered part of the cable with an insulation tube of at least the isolation voltage of the unit.

**⚠ CAUTION**

- Watch the polarity of Ei. Connection at incorrect polarity may damage the unit.
  - If Ei is disconnected, an unexpected voltage may be supplied by external noise. To assure a good connection, use crimped terminals.
  - Do not apply a voltage of 11 V or more, or reverse the voltage between control terminal 6 and +S terminal. Otherwise, the unit may be damaged.
- 

**NOTE**

- To reduce the effects of noise on output, use a 2-core shielded wire or a twisted-pair wire to connect to terminals, making them as short as possible. Longer wiring results in greater susceptibility to the effects of noise, and use of cables with antinoise measures may not solve the problem, resulting in improper operation.  
When using a shielded wire, connect the shield to the + (pos.) output terminal.
- The input impedance across the control terminal 6 and the +S terminal is 3-10 kΩ.

## Output voltage control with external voltage (continued)

- NOTE**
- For  $E_i$ , use a voltage source of low noise and good stability. Noise in  $E_i$  is multiplied by the amplification degree of the unit and appears in the unit's output. Thus, output ripple noise may not meet the unit's specifications.

4. Recheck that the connections.

- WARNING**
- After connections are complete, install the terminal cover.

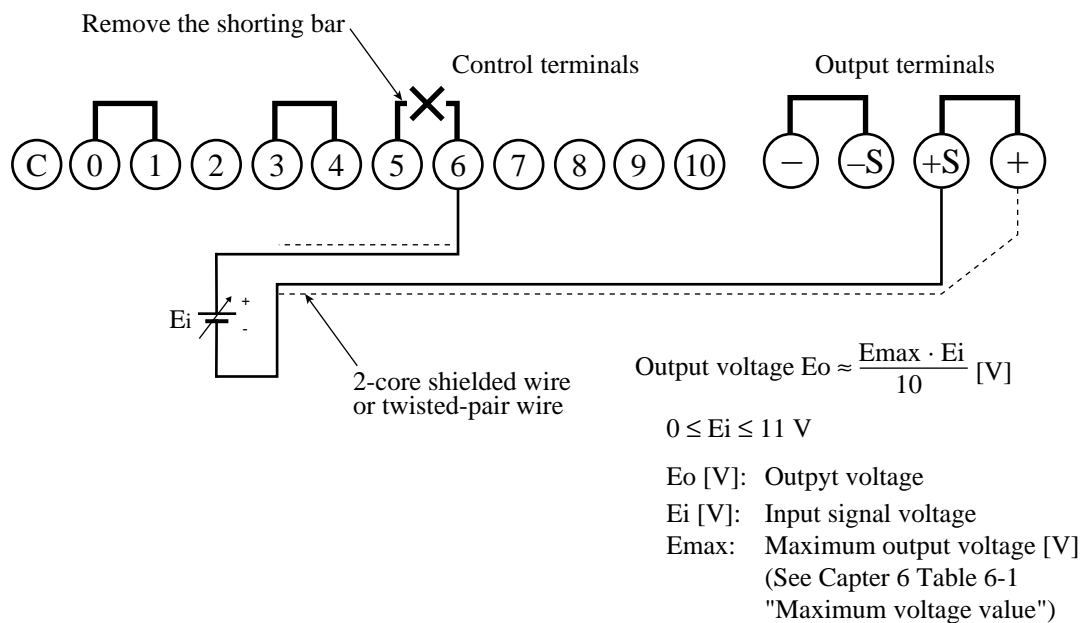

Fig. 4-6 Connections for output voltage control with external voltage

### Input offset voltage

The relationship between the input and output voltages of the unit is represented by input offset voltage, as shown in Fig. 4-7. This ensures a 0 V output even in the presence of residual resistance in the potentiometer or some wiring resistance during voltage control using an external resistor. When linearity is required to program the output voltage, adjust the input offset voltage using the  $V_{os}$  (output voltage offset) variable resistor on the front panel.

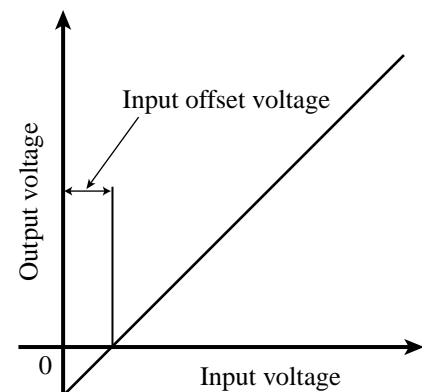

Fig. 4-7 Input offset voltage

## ■ When you wish to connect the shield to Ei

- 
- ⚠ CAUTION** • When connecting the shield to the Ei side, do not connect the shield to the + (pos.) output terminal of the unit.
- 

When using a shielded wire, some external voltage sources may require that the shield be connected to the external voltage source (Ei). In such cases, the grounding method used for the Ei and the unit creates a condition where the output is short-circuited, as shown in Fig. 4-8. Thus, do not connect the shield to the + (pos.) output terminal of the unit.

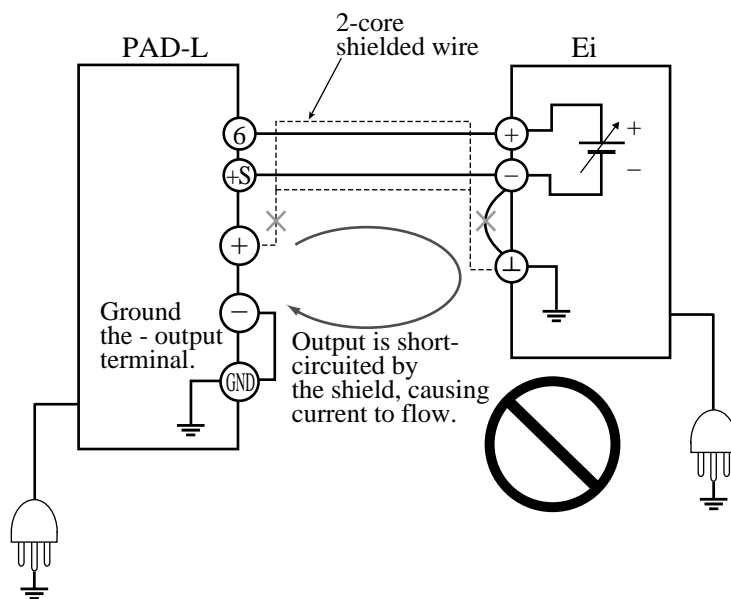

Fig. 4-8 A connection where output is short-circuited by the shield

- 
- ⚠ WARNING** • Do not ground the output of the Ei – float it instead. The potential of control terminals are nearly the same as that of the unit's + (pos.) output terminal, and short-circuit currents are provided to the signal line without a shield.
-

## 4.3 Output ON/OFF control

### 4.3.1 Output ON/OFF control (I)

This method is used to control ON/OFF for the output using external contact. When the external contact is closed, the output drops to nearly 0 V.

- 
- NOTE**
- In this method, the voltage set value is displayed when the CURRENT/VOLT. LIMIT switch is pressed while output is OFF, but not the current set value.
- 

- ⚠ CAUTION**
- A negative voltage of approx. 0.6 V is generated when the output is turned off, and a reverse current of approx. 10 mA may flow. If this negative voltage presents problems, use "Output ON/OFF control (II)" described in 4.3.2.
  - Do not use "Output ON/OFF control (I)" with "Output current control with an external voltage", as described in 4.4.2. Failure to do so may result in short-circuiting of the output of an external voltage source when output is OFF.
- 

### Connecting procedure

1. Turn off the POWER switch.
2. Connect a contact S (switch) across the control terminal 1 and 2 as shown in Fig. 4-9.

- 
- ⚠ WARNING**
- Isolate the external contact (S) and the cable connected to it with at least the isolation voltage of the unit. For details, see 2.6 "Grounding the output terminal."
  - When using a shielded cable for the connection, protect the uncovered part of the cable with an insulation tube of at least the isolation voltage of the unit.

- ⚠ CAUTION**
- If the contact S is disconnected, the output will be turned ON. Use crimp terminals or the like to secure this contact in place.
- 

- NOTE**
- To reduce the effects of noise on output, use a 2-core shielded wire or a twisted-pair wire to connect to terminals, making them as short as possible. Longer wiring results in greater susceptibility to the effects of noise, and use of cables with antinoise measures may not solve the problem, resulting in improper operation.  
When using a shielded wire, connect the shield to the + (pos.) output terminal.



- The release voltage across the control terminals 1 and 2 is approx. 5 V, and the short circuit current is approx. 1.5 mA.
- Use external contact points of contact rated 10 VDC min. and 100 mA min.
- For long-distance wiring, use a small relay and extend the coil side of that relay.

3. Recheck that the connections.

**⚠ WARNING** • After connections are complete, install the terminal cover.

**NOTE** • If the offset of the output current is shifted in the positive direction, the output will not fall to 0 V. If the output cannot be set to 0 V, adjust the I<sub>os</sub> variable resistor. For information on such adjustments, see "Current system adjustment procedure" described in 6.3.4, "Adjustment procedure", in Chapter 6.

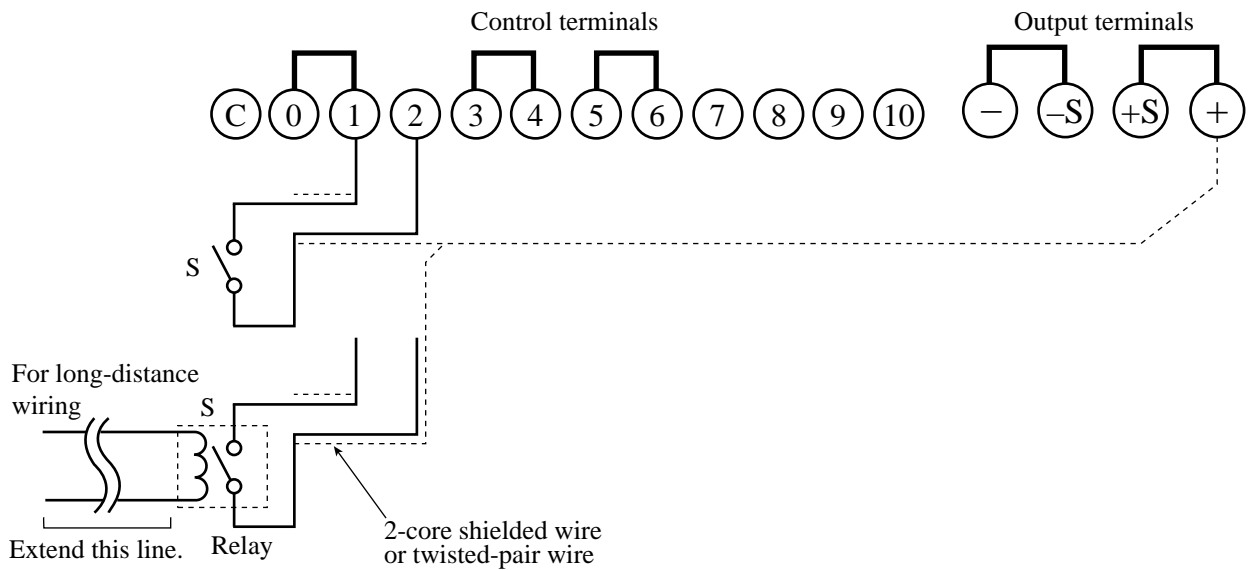

Fig. 4-9 Connection for output ON/OFF control (I)

## 4.3.2 Output ON/OFF control (II)

This method is used to control ON/OFF for the output using an external contact and is capable of accurately securing the output to 0 V when the external contact is closed.

---

**NOTE**

- If this method is used together with "Output voltage control with an external voltage" described in 4.2.3, ON/OFF for the output can no longer be controlled.
  - In this method, the current set value will be displayed when the CURRENT/VOLT. LIMIT switch is pressed while the output is OFF, but not the voltage set value.
- 

### Connecting and setting procedure

1. Turn off the POWER switch.
2. Connect a contact S (switch) across the control terminal 4 and 5 as shown in Fig. 4-10.

---

**⚠ WARNING**

- Isolate the external contact (S) and the cable connected to it with at least the isolation voltage of the unit. For details, see 2.6 "Grounding the output terminal."
- When using a shielded cable for the connection, protect the uncovered part of the cable with an insulation tube of at least the isolation voltage of the unit.

**⚠ CAUTION**

- If the contact S is disconnected, the output will be turned ON. Use crimp terminals or the like to secure this contact in place.
- 

**NOTE**

- To reduce the effects of noise on output, use a 2-core shielded wire or a twisted-pair wire to connect to terminals, making them as short as possible. Longer wiring results in greater susceptibility to the effects of noise, and use of cables with antinoise measures may not solve the problem, resulting in improper operation.  
When using a shielded wire, connect the shield to the + (pos.) output terminal.
  - The release voltage across the control terminals 4 and 5 is approx. 10 V, and the short circuit current is approx. 2 mA.
  - Use external contact points of contact rated 20 VDC min. and 100 mA min.
  - For long-distance wiring, use a small relay and extend the coil side of that relay.
-

3. Recheck that the connections.

**⚠ WARNING** • After connections are complete, install the terminal cover.

4. Turn on the POWER switch.

5. Turn on the external contact (S).

6. Adjust the V.os variable resistor on the front panel so that the output voltage is 0 V.

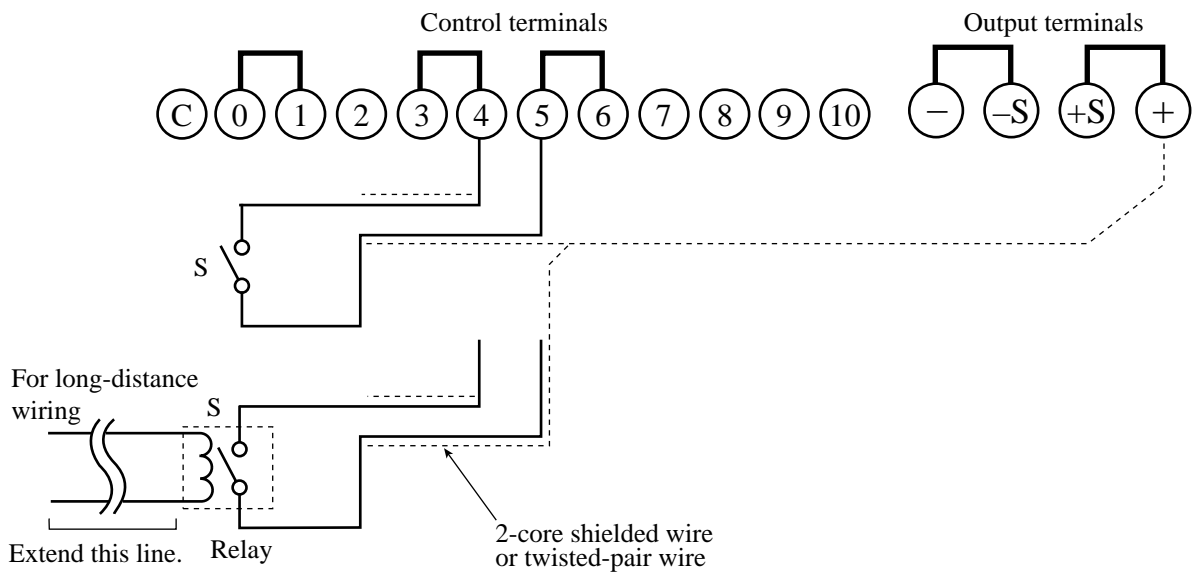

Fig. 4-10 Connection for output ON/OFF control (II)

## 4.4 CC mode by remote control

### 4.4.1 Output current control with external resistor

#### Connecting and setting procedure

1. Turn off the POWER switch.
2. As shown in Fig. 4-11, remove the shorting bar across the control terminals 0 and 1.
3. Connect an external resistor (R3) across the control terminals 1 and 2 as shown in Fig. 4-11.

---

**⚠ WARNING**

- Isolate the external resistor (R3) and the cable connected to it with at least the isolation voltage of the unit. For details, see 2.6 "Grounding the output terminal."
- When using a shielded cable for the connection, protect the uncovered part of the cable with an insulation tube of at least the isolation voltage of the unit.

**⚠ CAUTION**

- If R3 is disconnected, excessive current may be applied to a load. To assure a good connection, use crimped terminals.
- To use R3 which consists of a multiple number of fixed resistors and a switch, and select one of them for control, use a short circuit type or continuous type switch.

---

**NOTE**

- To reduce the effects of noise on output, use a 2-core shielded wire or a twisted-pair wire to connect to terminals, making them as short as possible. Longer wiring results in greater susceptibility to the effects of noise, and use of cables with antinoise measures may not solve the problem, resulting in improper operation.  
When using a shielded wire, connect the shield to the + (pos.) output terminal.
- Approx. 1 mA of current always flows in R3. For R3, use a 1/2 W or larger resistor with a good temperature coefficient and small aging effect such as metal film or wire-wound type resistor.

4. Recheck that the connections.

---

**⚠ WARNING**

- After connections are complete, install the terminal cover.
-

5. Turn on the POWER switch.
6. Adjust the I.os variable resistor on the front panel so that the output current becomes 0 A when R3 is zero.

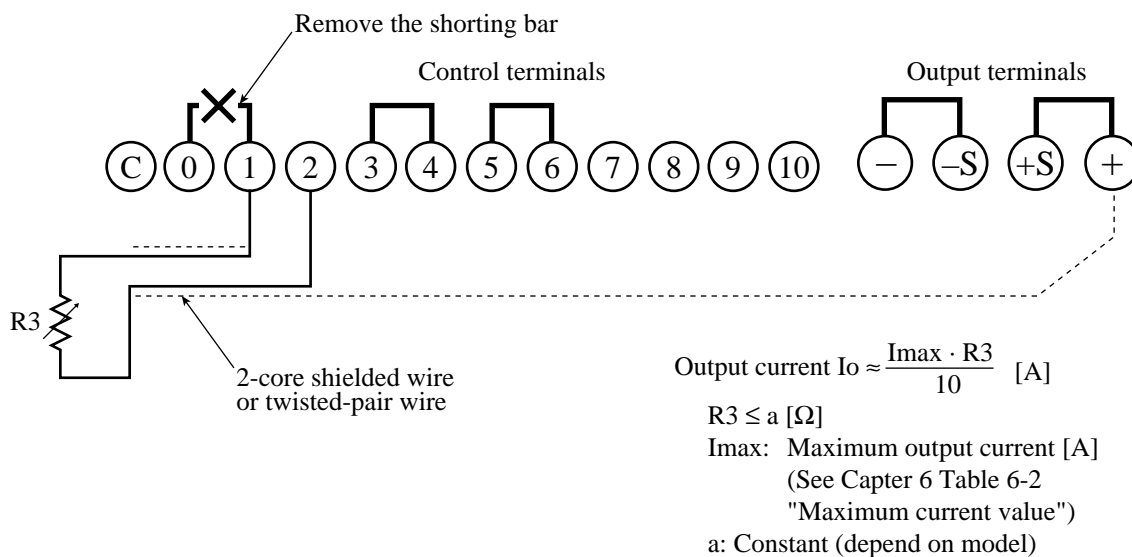

Fig. 4-11 Connections for output current control with external resistor

Table 4-2 Constant (depend on model)

Type III	PAD 16-100L	PAD 35-50L	PAD 35-60L	PAD 60-35L	PAD 110-20L	PAD 250-8L
a [ ]	550	1000	1000	1000	1000	1000
Type IV	PAD 35-100L	PAD 60-60L	PAD 110-30L	PAD 250-15L		
a [ ]	550	550	550	550		
Type V	PAD 35-200L	PAD 60-120L	PAD 110-60L			
a [ ]	550	550	550			

## 4.4.2 Output current control with external voltage



- **To do this, open the unit cover and change a switch on the internal printed board.**  
**These control settings must be performed by qualified personnel having sufficient expertise and familiarity with the procedure.**

### NOTE

- When controlling the unit using an external voltage source which has a quick rising time relative to the capacitive load, the phase control circuit of the unit cannot respond to the external voltage, which may cause AC components to be superimposed on the rising waveform.

### Connecting and setting procedure

1. Turn off the switch on the switchboard.
2. Turn off the POWER switch.
3. Remove the cover from the unit. For information on removing it, see 6.3.3 "Removing the cover".
4. Set SW1 on the PCB A-200 to the upper position. See Fig. 4-12.  
For the location of PCB A-200 in the unit, see Figs. 6-5, 6-6, and 6-7 in Chapter 6 "Maintenance".

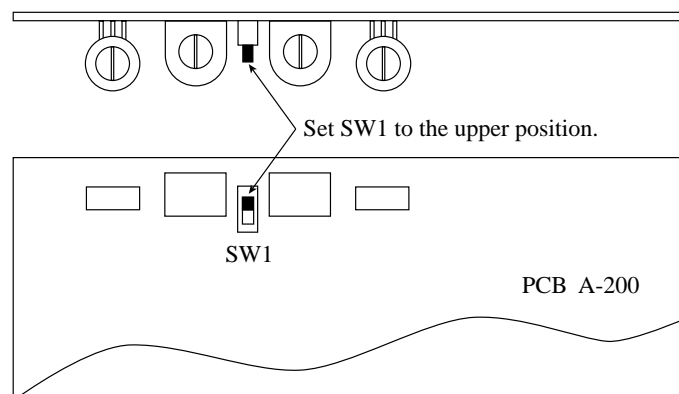

Fig. 4-12 SW1 on the PCB A-200

5. Replace the unit cover.
6. Remove the shorting bar from terminals 0 and 1 of the control terminal board, as shown in Fig. 4-13.

7. Connect an external voltage source ( $E_i$ ) and capacitor ( $C$ ) between terminals 1 and 2 of the control terminal board, as shown in Fig. 4-13.

**⚠ WARNING**

- Isolate the external voltage source ( $E_i$ ) and the cable connected to it with at least the isolation voltage of the unit. Float  $E_i$  outputs instead of grounding them (floating). For details, see 2.6 "Grounding the output terminal."

- When using a shielded cable for the connection, protect the uncovered part of the cable with an insulation tube of at least the isolation voltage of the unit.

**⚠ CAUTION**

- Watch the polarity of  $E_i$ . Connection at incorrect polarity may damage the unit.

- If  $E_i$  is disconnected, an unexpected voltage may be supplied by external noise. To assure a good connection, use crimped terminals.

- Do not apply the  $E_{imax}$  or more, or reverse the voltage between control terminals 1 and 2. Otherwise, the unit may be damaged.

**NOTE**

- To reduce the effects of noise on output, use a 2-core shielded wire or a twisted-pair wire to connect to terminals, making them as short as possible. Longer wiring results in greater susceptibility to the effects of noise, and use of cables with antinoise measures may not solve the problem, resulting in improper operation.

When using a shielded wire, connect the shield to the + (pos.) output terminal.

- For  $E_i$ , use a voltage source of low noise and good stability. Noise in  $E_i$  is multiplied by the amplification degree of the unit and appears in the unit's output. Thus, output ripple noise may not meet the unit's specifications.

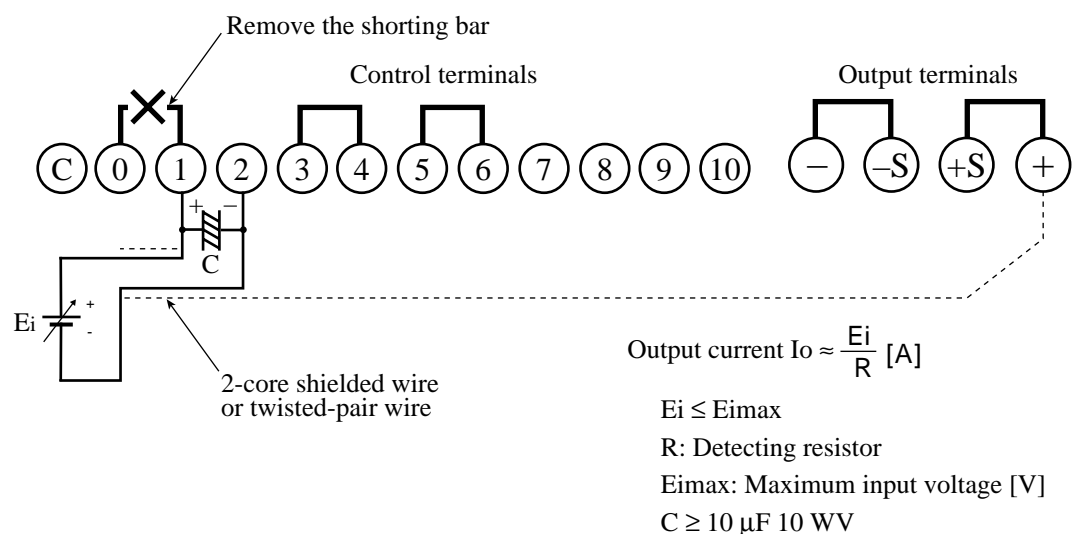

Fig. 4-13 Connections for output current control with external voltage

## Output current control with external voltage (continued)

Table 4-3 Constant (depend on model)

Type III	PAD 16-100L	PAD 35-50L	PAD 35-60L	PAD 60-35L	PAD 110-20L	PAD 250-8L
R [ $\Omega$ ]	0.003	0.01	0.0083	0.033	0.05	0.1
Eimax [V]	0.33	0.55	0.55	1.27	1.1	0.88

Type IV	PAD 35-100L	PAD 60-60L	PAD 110-30L	PAD 250-15L
R [ $\Omega$ ]	0.0055	0.0075	0.015	0.05
Eimax [V]	0.61	0.5	0.5	0.8

Type V	PAD 35-200L	PAD 60-120L	PAD 110-60L
R [ $\Omega$ ]	0.001	0.003	0.0075
Eimax [V]	0.22	0.4	0.5

8. Recheck that the connections.

**⚠ WARNING** • After connections are complete, install the terminal cover.

**⚠ CAUTION** • If the output current control with external voltage function is not to be used, set SW1 on PCB A-200 to the lower position.

### ■ Input offset voltage

The relationship between the input and output voltages of the unit is represented by input offset voltage, as shown in Fig. 4-14. This ensures a 0 A output even when there is residual resistance of the potentiometer or some wiring resistance during current control using an external resistor. When linearity is required to program the output current, adjust the input offset voltage using the I.os (output current offset) variable resistor on the front panel.

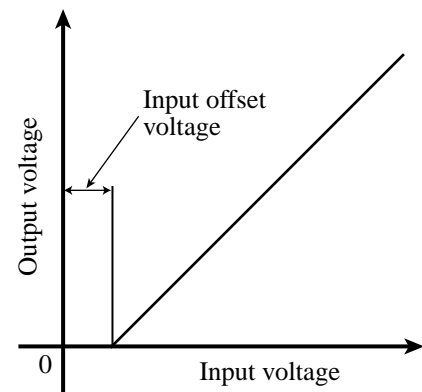

Fig. 4-14 Input offset voltage



## ■ When you wish to connect the shield to Ei

- 
- ⚠ CAUTION** • When connecting the shield to the Ei side, do not connect the shield to the + (pos.) output terminal of the unit.
- 

When using a shielded wire, some external voltage sources may require that the shield be connected to the external voltage source (Ei). In such cases, the grounding method used for the Ei and the unit creates a condition where the output is short-circuited, as shown in Fig. 4-15. Thus, do not connect the shield to the + (pos.) output terminal of the unit.

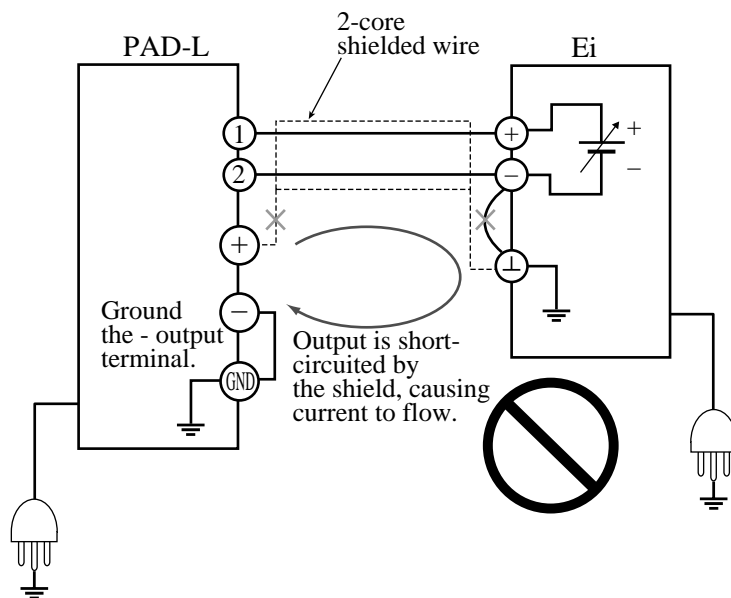

Fig. 4-15 A connection where output is short-circuited by the shield

- 
- ⚠ WARNING** • Do not ground the output of the Ei – float it instead. The potential of control terminals are nearly the same as that of the unit's + (pos.) output terminal, and short-circuit currents are provided to the signal line without a shield.
-

---

## 4.5 Master-slave-control parallel operation

It is possible to increase the current capacity by connecting a maximum two slave units in parallel to one master unit. In a master-slave-control parallel operation system, the output preset for all the units connected in parallel can be provided only on the master unit.

- 
- ⚠ CAUTION**
- **Parallel connection is possible only for the PAD-L series power supplies that have the same rated output voltage and rated output current. Connecting power supplies of different rated outputs in parallel may cause malfunction.**
  - **The number of slave units to be connected to the master unit is up to 2. To connect three or more slaves, contact Kikusui distributor/agent.**
- 

### ■ Presetting of OVP trip points in parallel operation

There is a link between the master unit and slave units on OVP operation in parallel operation. Preset OVP trip points as follows.

When carrying out parallel operation, OVP (overvoltage protection) trip points should be preset for both the master unit and for all slave units. For example, if the master unit becomes unable to control the slave units – because, for example, its POWER switch is inadvertently turned off during parallel operation – the slave units may output their maximum output voltage. If an appropriate OVP trip point has been preset for these units, however, the load can still be protected.

In parallel operation, the OVP trip points for slave units should be set to slightly higher values than that used for the master unit. However, do not preset them to a value exceeding the maximum voltage (see Chapter 6, Table 6-1.)

If the OVP trip points for the slave units are preset to a value below that of the master unit, their overvoltage protection will function first, turning off output from the slaves but not from the master unit.

---

## Connecting and setting procedure for parallel operation

1. Determine the master unit.
2. Check that no load is connected between the output terminals of the master and slave units.
3. Set the OVP (overvoltage protection) trip points for the master and slave units.  
Set the OVP trip points for the slave units to a value slightly higher than that used for the master unit. However, do not set them to a value exceeding the maximum voltage value (Chapter 6, Table 6-1.)
4. While pressing the CURRENT/VOLT. LIMIT switch of the master unit, set the output voltage and current.
5. Turn off all POWER switches of the master and slave units.
6. Turn the VOLTAGE control and the CURRENT control of each slave unit fully clockwise.  
Set the output of each slave unit to the maximum level, so that it can follow the output setting of the master unit.
7. Connect the master and slave units and a load, as shown in Fig. 4-16.

---

**⚠ WARNING** • Isolate the cable connecting one control terminal to the other with at least the isolation voltage of the unit. For details, see 2.6 "Grounding the output terminal."

**⚠ CAUTION** • Pay close attention to the current capacity and withstand voltage of cables to be used for the load cables. For more information, see 3.3.1 "Load cables".

- Use wires of the same length and size for connecting the load and each unit. Use of varying lengths and size may cause different output current from each unit.
- To assure good connection, use crimped terminals.
- Position each unit with sufficient space around it.

---

**NOTE** • When performing remote sensing in master-slave-control parallel operation, prepare the sensing wiring only for the master unit. For information on connection, see 4.1 "Remote sensing".

---

## Connecting and setting procedure for parallel operation (continued)

8. Connect an electrolytic capacitor (C) with a capacity of 100 to 100,000  $\mu\text{F}$  to the load terminals as necessary.

If the length of wiring to a load extends to 3 m or more, the phase shift caused by the inductance and capacitance of the wiring becomes non-negligible, thereby causing oscillation. In such cases, the capacitor (C) prevents oscillation.

**CAUTION** • Use a capacitor (C) whose withstand voltage is 120% or more of the unit's rated output voltage.

9. Recheck that the connections.

**WARNING** • After connections are complete, install the terminal cover.

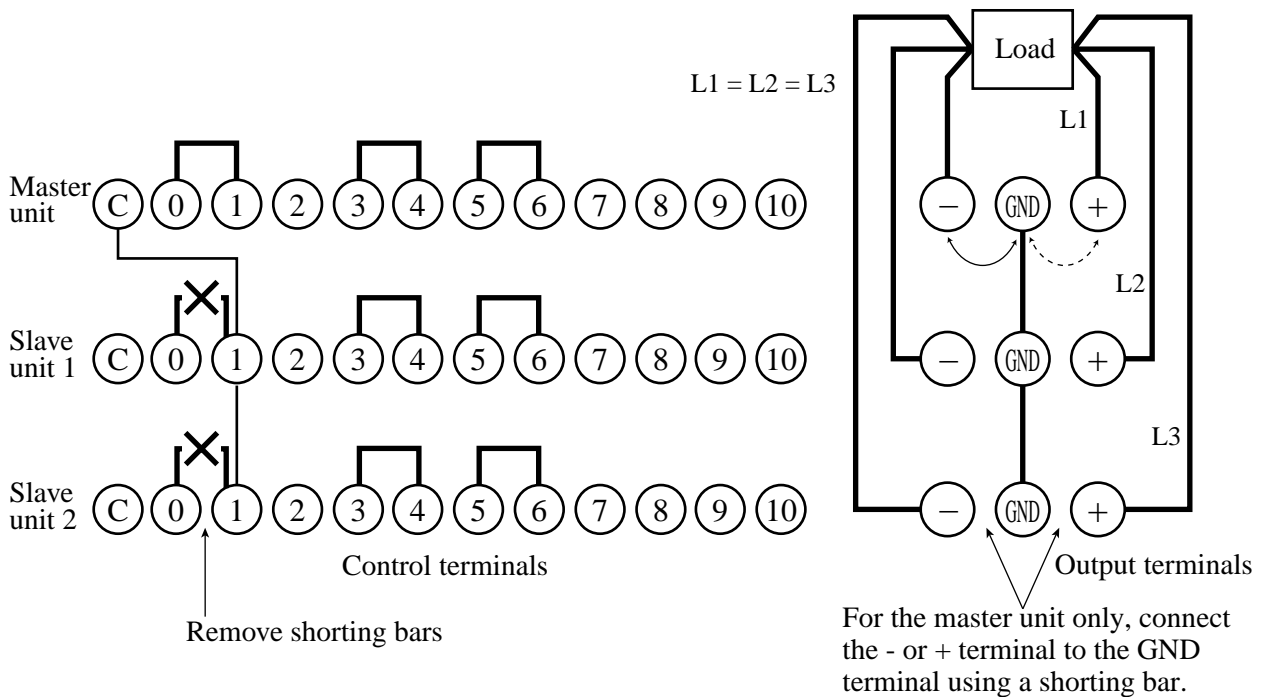

Fig. 4-16 Connection for master-slave-control parallel operation

---

## Starting master-slave-control parallel operation

- 
- ⚠ CAUTION** • To start master-slave-control parallel operation, always follow the procedure below.

If the **POWER** switch of the master unit is turned **ON** before those of the slave units, the master also outputs a portion of the current output through the slaves, disabling constant voltage operations.

---

1. Check that all **POWER** switches of the master and slave units are **OFF**.
2. Turn on the **POWER** switch of each slave unit.  
"C.C" lights up on the control panel of each slave unit, indicating that the unit is in constant current operation mode. Because no signal is issued from the master unit, the master remains in standby status.
3. Turn on the **POWER** switch of the master unit.  
"C.V" lights up on the master unit control panel, indicating that the unit is in constant voltage operation mode.
4. The same output voltage and current indicated on the master unit are also displayed on all the slave units.  
This means that the total current of all the units is applied to the load.

## Finishing the master-slave-control parallel operation

- 
- ⚠ CAUTION** • To finish master-slave-control parallel operation, always observe the following procedure.

If the **POWER** switches of the slave units is turned **ON** before those of the master unit, the master also outputs a portion of the current output through the slaves, disabling constant voltage operations.

---

1. Turn off the **POWER** switch of the master unit.
2. Turn off the **POWER** switch of each slave unit.

## 4.6 Master-slave-control series operation

It is possible to increase the output voltage by connecting several slave units in series to one master unit. In a master-slave-control series operation system, a preset output for all the units connected in series can be designated only from the master unit.



### WARNING

- **Be sure to observe the limitation on the maximum number of units that can be connected in series. If the maximum output voltage exceeds the isolation voltage, it may create a danger of electric shock.**



### CAUTION

- **Only identical TYPE models in the PAD-L series can be connected in series to the master unit. Connecting different TYPE models of the PAD-L series may result in failure.**
  - **In case of master-slave-control series operation, the master unit, slave unit 1, and slave unit 2 are started in this order. Thus, the rise in output will be delayed in comparison with single-unit operation. This may cause AC ripple components to be superimposed on the output voltage. If rise waveform becomes a problem, use a single high-output-voltage unit.**
- 

### ■ Number of units connectable in series:

The number of slave units to be connected in series is determined by the rated output voltage and isolation voltage of each unit.

Taking the PAD35-50L as an example for series connection:

Since the rated output voltage is 35 V, and the isolation voltage is  $\pm 250$  V,  
 $250/35 = 7.1$ , i.e., up to 7 units including the master unit can be connected in series.

The rated output voltage and the isolation voltage are described in Chapter 7 "Specifications"

### ■ Presetting of OVP trip points in series operation

When carrying out series operation, OVP (overvoltage protection) trip points should be preset for both the master unit and for all slave units.

In series operation, the OVP trip points for slave units should be set to slightly higher values than that used for the master unit.

Set the OVP trip points as follows:

$$\frac{\text{OVP set value of master unit}}{\text{Rated output voltage of master unit}} < \frac{\text{OVP set value of slave units}}{\text{Rated output voltage of slave units}}$$

If the OVP trip points for the slave units are preset to a value below that of the master unit, their overvoltage protection will function first, turning off output from the slaves but not from the master unit.

## Connecting and setting procedure for series operation

1. Determine the master unit.  
When the same TYPE models of the PAD-L series with different output capacities are connected, the output is limited by the power supply with the smallest rated output current. Thus, that unit should be used as the master unit.
2. Check that no load is connected between the output terminals of the master and slave units.
3. Set the OVP (overvoltage protection) trip points for the master and slave units.  
Set the OVP trip points for the slave units to a value slightly higher than that used for the master unit.
4. While pressing the CURRENT/VOLT. LIMIT switch of the master unit, set the output voltage and current.
5. Turn off all POWER switches of the master and slave units.
6. Turn the VOLTAGE control and the CURRENT control of each slave unit fully clockwise.  
Set the output of each slave unit to the maximum level, so that it can follow the output setting of the master unit.
7. Connect the master and slave units and a load, as shown in Fig. 4-17.

- 
- ⚠ WARNING**
- To avoid electric shock, isolate the external resistor from other parts. The external resistance has almost the same potential as the + (pos.) output terminal of each output.
  - Connect any one of the output terminals to the GND (chassis ground) terminal using a shorting bar. The chassis of the master and slave units have the same potential as the output terminals to be connected. Take care to avoid electric shocks.

- ⚠ CAUTION**
- Pay close attention to the current capacity and withstand voltage of cables to be used for the load cables. For more information, see 3.3.1 "Load cables".
  - To assure good connection, use crimped terminals.
  - For external resistors, use a 1 W or larger resistor with a good temperature coefficient and small aging effect such as metal film or wire-wound type resistor.
  - Position each unit with sufficient space around it.

- 
- NOTE**
- When performing remote sensing in master-slave-control series operations, do the sensing wiring for the + (pos.) output terminal of the master unit and the - (neg.) output terminal of the slave unit at the end. For information on connecting wires for remote sensing, see 4.1 "Remote sensing".
  - When using two power supplies as dual-tracking power supplies, it is recommended that either the - (neg.) output terminal of the master unit or the + (pos.) output terminal of the slave unit be connected to the GND (chassis ground) terminal.
  - Select the shortest and heaviest-gauge wires for output wiring used to connect the power supplies. A large voltage drop in the wires will result in large potential differences or load variations between the power supplies.
-

## Connecting and setting procedure for series operation (continued)

8. Recheck that the connections.

**⚠ WARNING** • After connections are complete, install the terminal cover.

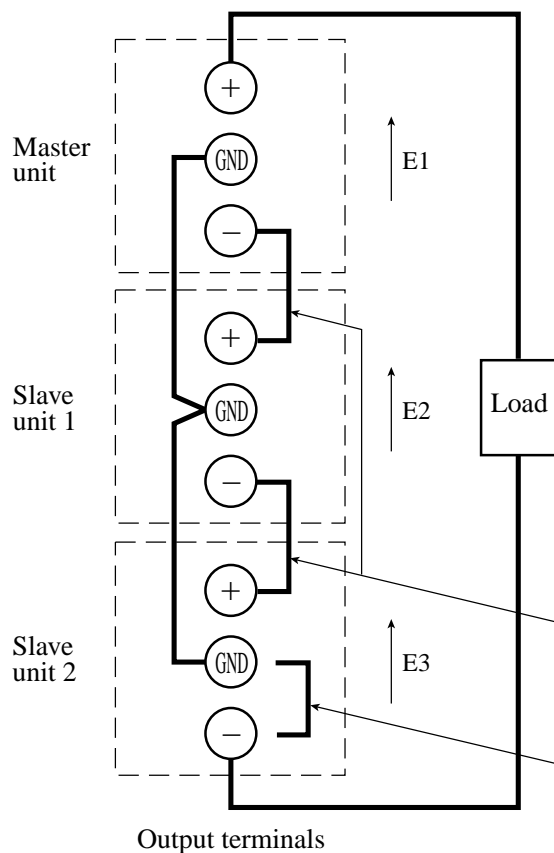
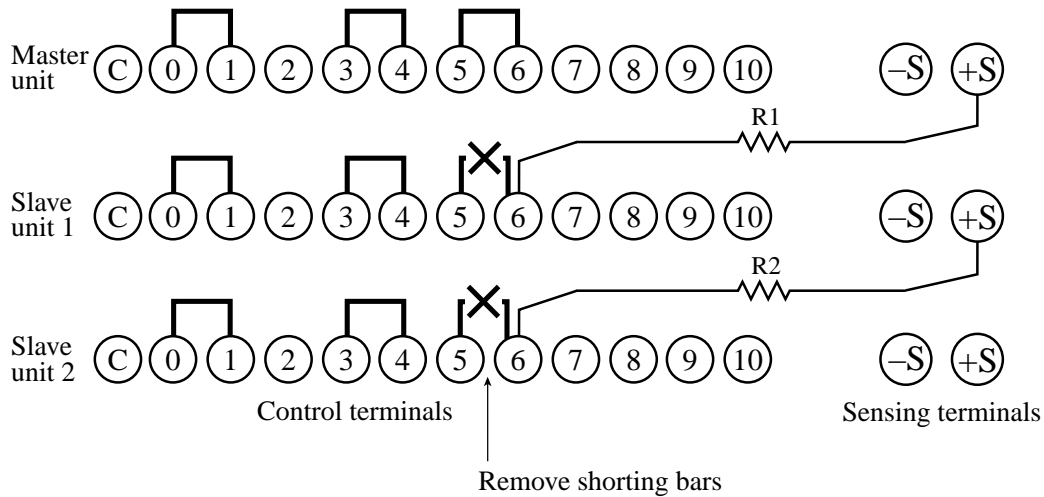

### Determining the external resistor

$$R1 \approx \left( \frac{E1}{E2} \times a \right) - b$$

E1 [V]: Output voltage of the master unit  
 E2 [V]: Output voltage of slave unit 1 when the output voltage of the master unit is E1

Note that  $R1 \geq 0$  [k $\Omega$ ]      a, b: Constants of slave unit 1

$$E2 \leq \frac{a}{b} E1 \text{ ----- Condition of range from which } E2 \text{ can be taken}$$

R2 can be determined in the same way by substituting E2 and E3 into the above equation in place of E1 and E2, respectively. That is, slave unit 1 becomes the master unit while slave unit 2 becomes slave unit 1.

Select the shortest and heaviest-gauge wires practical for this wiring.

Connect any one of the output terminals to the GND (chassis ground) using a shunting bar.

Fig. 4-17 Connection for master-slave-control series operation



Table 4-4 Constant (depend on model)

Type III	PAD 16-100L	PAD 35-50L	PAD 35-60L	PAD 60-35L	PAD 110-20L	PAD 250-8L
Type IV	-	PAD 35-100L	-	PAD 60-60L	PAD 110-30L	PAD 250-15L
Type V	-	PAD 35-200L	-	PAD 60-120L	PAD 110-60L	-
a [k ]	5.2	12	12	30	108	248
b [k ]	3.3	3.4	3.4	5	9.8	9.9

## Starting master-slave-control series operation

---

**⚠ CAUTION** • To start master-slave-control series operation, always follow the procedure below.

---

1. Check that all POWER switches of the master and slave units are OFF.
2. Turn on the POWER switch of each slave unit.  
"C.V" lights up on the control panel of each slave unit, indicating that the unit is in constant voltage operation mode. Because no signal is issued from the master unit, the master remains in standby status.
3. Turn on the POWER switch of the master unit.  
"C.V" lights up on the master unit control panel, indicating that the unit is in constant voltage operation mode.

## Finishing the master-slave-control series operation

---

**⚠ CAUTION** • To finish master-slave-control series operation, always observe the following procedure.  
**Failure may result if the POWER switch of a slave unit is turned off before that of the master unit.**

---

1. Turn off the POWER switch of the master unit.
2. Turn off the POWER switch of each slave unit.

---

## 4.7 Shutting off the POWER switch

If terminals 7 and 8 of the control terminal board are short-circuited, the POWER switch is shut off instantly.

---

### **⚠ WARNING**

- **Avoid touching terminals 7 and 8 of the control terminal board immediately after shutting off power. Terminals 7 and 8 have the same potential as the + terminal of the unit rectifier smoothing capacitor.**

**Immediately after power is shut off, a large-capacity capacitor in the rectifier circuit retains energy levels hazardous to the human body. It takes more than 30 seconds for this energy to dissipate to safe levels.**

---

### Connecting procedure

1. Turn off the POWER switch.
2. Connect a contact S (switch) across the control terminal 7 and 8 as shown in Fig. 4-18.

---

### **⚠ WARNING**

- **Isolate the external contact (S) and the cable connected to it with at least the isolation voltage of the unit. Float a signal from the external contact. Terminals 7 and 8 of the control terminal board have the same potential as the + terminal of the unit's rectifier smoothing capacitor, and the voltage applied to them will exceed the output voltage.**

- **Since terminals 7 and 8 of the control terminal board have the same potential as the + terminal of the unit's rectifier smoothing capacitor, short-circuiting them with the + (pos.) output terminal also short-circuits the control transistor, resulting in an uncontrolled output voltage across the load.**

**Moreover, when the - (neg.) output terminal is connected to the GND (chassis ground) terminal, contact between terminal 7 or 8 and the chassis short-circuits the secondary output of the transformer. This may result in electric shock or output short-circuiting hazards.**

### **⚠ CAUTION**

- **To assure a good connection, use crimped terminals.**

---

### **NOTE**

- Use external contact points of contact rated 30 VDC min. and 250 mA min.
  - For long-distance wiring, use a small relay and extend the coil side of that relay.
-

3. Recheck that the connections.

**⚠ WARNING** • After connections are complete, install the terminal cover.

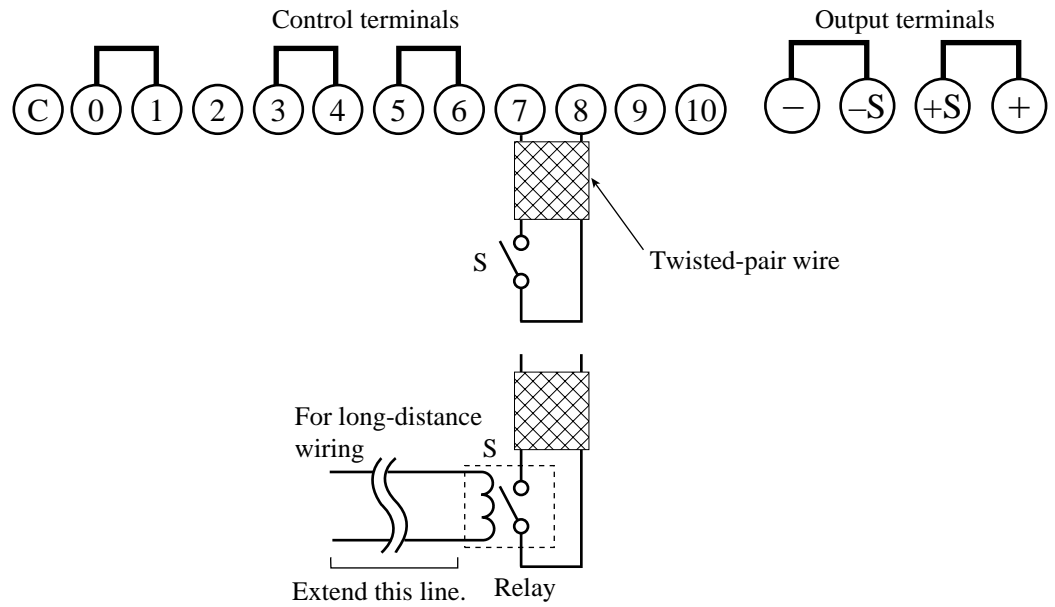

Fig. 4-18 Connection for shutting off the POWER switch

---

## 4.8 Constant current charge of a battery/ capacitor

This application example illustrates charging a battery or capacitor at constant current with the unit.

In Fig. 4-19, use the unit VOLTAGE setting knob to set a charge-end voltage and the CURRENT setting knob to set a charge current. Constant current charging begins when the external contact (S) is closed, and the unit enters the constant voltage mode when the output voltage of the unit reaches the set charge end voltage, halting constant current charging.

- 
- ⚠ CAUTION**
- **Be careful to avoid overcharging loads that can be damaged by overcharging, such as batteries.**  
**For loads for which constant voltage charging presents problems, Kikusui's power supply controller allows monitoring of constant voltage and constant current modes. Contact Kikusui distributor/ agent.**
  - **In Fig. 4-19, note the setting of the charge-end voltage. A voltage applied across a battery or capacitor will be lower than the output voltage of the unit by a portion of the forward voltage (VF) of the reverse-current prevention diode (DRP).**
- 

### Connecting procedure

1. Turn on the POWER switch.
2. While pressing the CURRENT/VOLT. LIMIT switch, set the charge end voltage with the VOLTAGE setting knob and the charge current with the CURRENT setting knob.
3. Turn off the POWER switch.

4. Connect a battery or capacitor across the output terminals as shown in Fig. 4-19.

**⚠ WARNING** • Connect the unit and battery to the same polarity. In addition to damaging the unit, connecting them to opposite polarities may result in battery failure.

**⚠ CAUTION** • When a charged battery is connected to the unit, if the POWER switch of the unit is OFF or the output voltage of the unit is lower than the charged battery voltage, a current of several hundred mA flows into the unit. If this current presents problems, connect a reverse-current prevention diode (DRP) to the circuit in series, as shown in Fig. 4-19.

When using PAD16-100L, PAD35-200L, PAD60-120L, or PAD110-60L, note that a charged current can flow abruptly from the battery into an electrolytic capacitor within the unit, which may deteriorate and eventually blow the output fuse.

When any of the power supplies noted above is used in this operation, connect DRP or adjust the output voltage of the power supply equal to the battery voltage.

- The remote sensing function cannot be used when the DRP is connected.
- To protect the power supply and the load, select DRP that meets the following requirements:
  1. Reverse-voltage tolerance is at least two times the rated output voltage of the power supply.
  2. Forward current capacity is three to ten times the rated output current of the power supply.
  3. A diode with small loss
- Be sure to take account of heat generation from DRP. DRP may burn unless adequately dissipated.

5. Recheck that the connections.

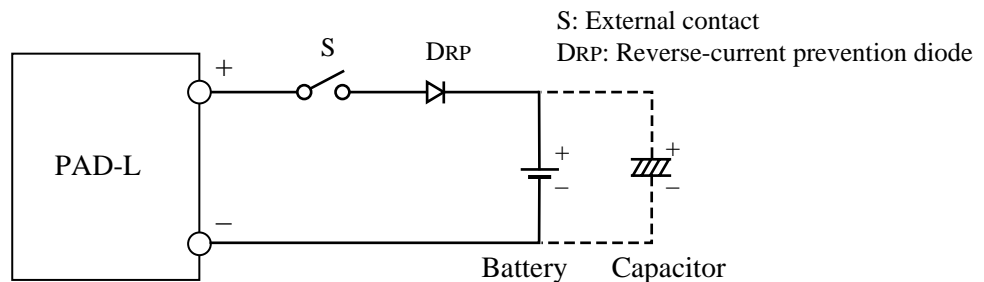

Fig. 4-19 Constant current charge circuit



# 5

## **Chapter 5 Names and Functions of Controls**

Provides an outline of the switches and terminals on the panels, including their names and functions.

## 5.1 Front panel

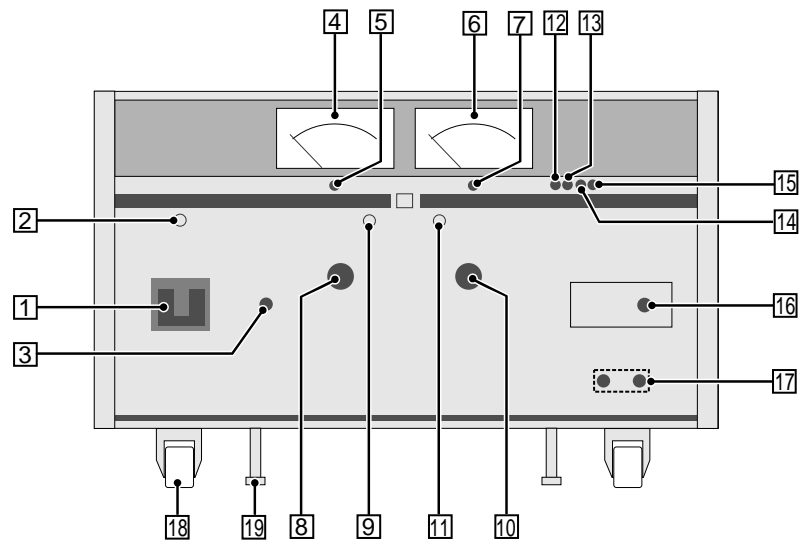

Fig. 5-1 PAD-L series TYPE III models front panel

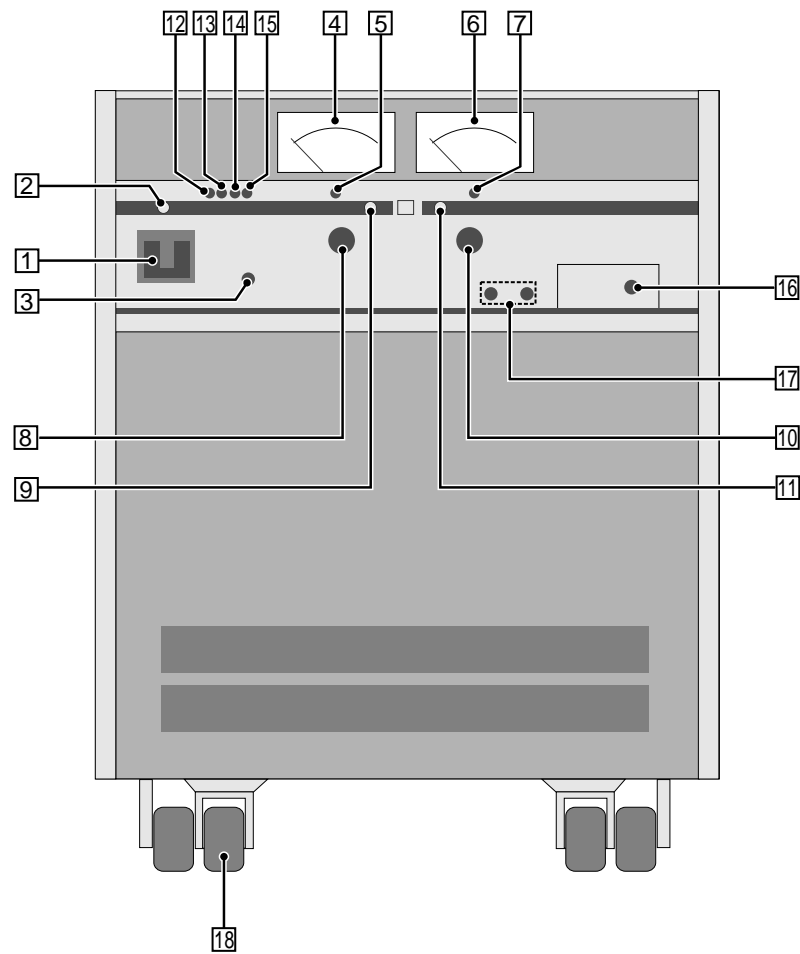

Fig. 5-2 PAD-L series TYPE IV models front panel



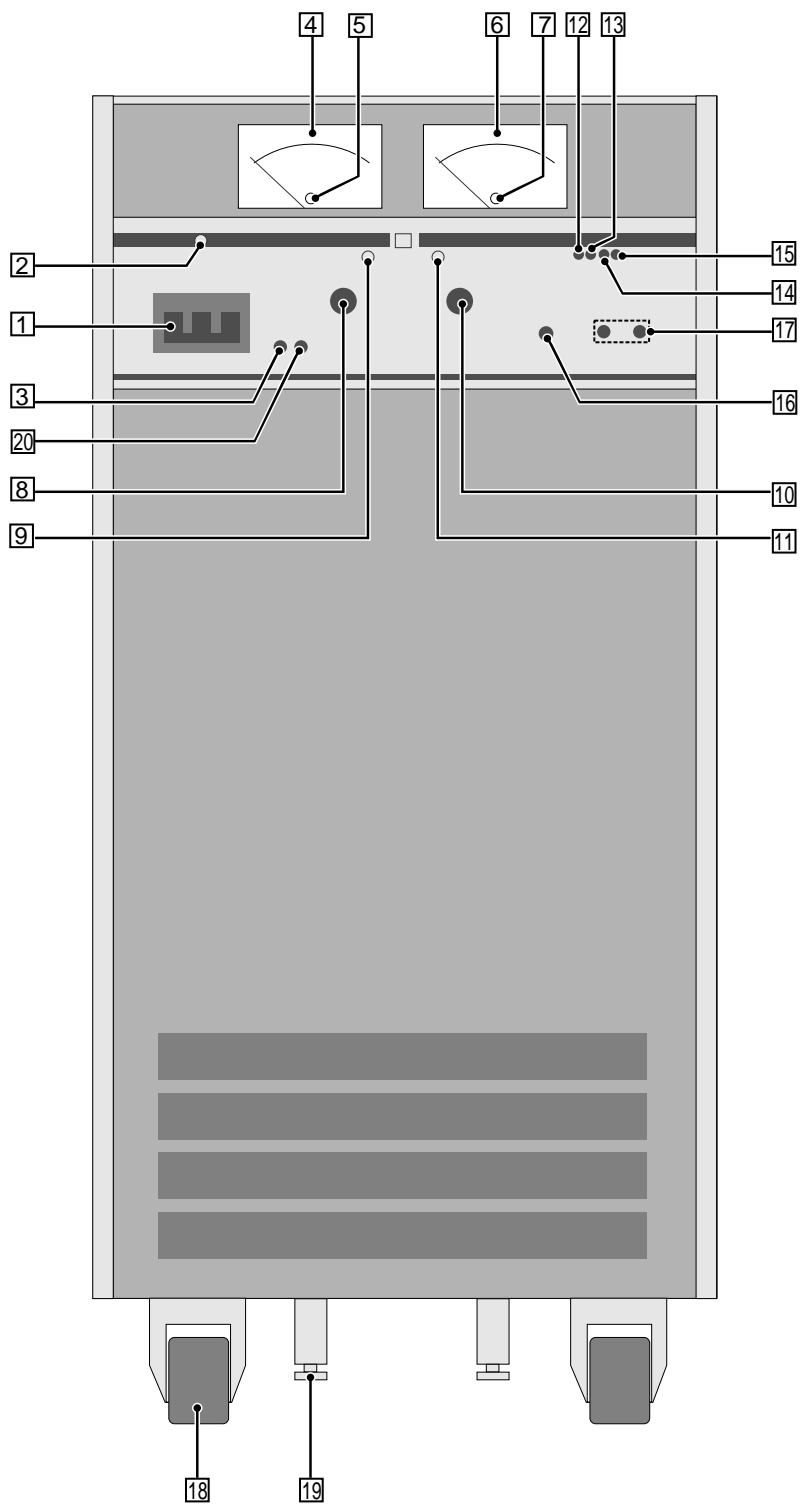

Fig. 5-3 PAD-L series TYPE V models front panel

## Front panel (continued)

**1** POWER switch

Turns the power of the unit on and off. Flip up the lever to turn the power ON, and flip it down to turn the power OFF.

**NOTE**

- If any of the built-in protective circuits (overvoltage protection, voltage detection, current detection, and temperature detection circuits) is tripped, the POWER switch will be shut off automatically. Once shut off, the power switch cannot be turned on immediately. Eliminate the cause of the problem and wait approximately 60 seconds before turning on the POWER switch.

**2** POWER indication lamp

Indicates that power is on.

**3** CURRENT/VOLT. LIMIT switch

When this switch is held down, the ammeter indicates a constant current set-value while the voltmeter indicates a constant voltage set-value.

**4** Ammeter

Indicates the output current; of class 2.5 (the TYPE V model uses a class-1.5 ammeter).

**5** Ammeter zero-adjustment

Allows mechanical adjustment of the ammeter pointer to zero. For information on performing adjustments, see 6.3.4 "Adjustment procedure".

**6** Voltmeter

Indicates the output voltage; of 2.5 class (the TYPE V model uses a class-1.5 voltmeter).

**7** Voltmeter zero-adjustment

Allows mechanical adjustment of the voltmeter pointer to the zero. For information on performing adjustments, see 6.3.4 "Adjustment procedure".

**8** CURRENT setting knob

This is used to set current for constant current operation mode. (1 turn)

The knob will be either one-piece or two-piece, depending on the model.

The following models have two-piece setting knobs.

- TYPE III PAD16-100L
- All TYPE IV models
- All TYPE V models

A two-piece knob consists of two concentric knobs, with the outer knob used for coarse adjustment and the inner knob used for fine adjustment.

**9** C.C lamp

This is displayed when the unit is in its constant current operation mode.

- 
- 10** **VOLTAGE setting knob**  
This is used to set output voltage for constant voltage operation mode. (10 turns)
- 11** **C.V lamp**  
This is displayed when the unit is in its constant voltage operation mode.
- 12** **A.FS variable resistor**  
This is used to adjust the ammeter. For information on performing adjustments, see 6.3.4 "Adjustment procedure".
- 13** **V.FS variable resistor**  
This is used to adjust the voltmeter. For information on performing adjustments, see 6.3.4 "Adjustment procedure".
- 14** **I.OS variable resistor**  
This is used to adjust the output current offset resulting when the CURRENT setting knob is turned to the extreme counterclockwise position. It is also used to adjust input offset voltage for "Output current control with an external voltage", as in 4.4.2.
- 15** **V.OS variable resistor**  
This is used to adjust the output voltage offset resulting when the VOLTAGE setting knob is turned to the extreme counterclockwise position. It is also used to adjust the input offset voltage for "Output voltage control with an external voltage", as in 4.2.3.
- 16** **O.V.P variable resistor**  
This is used to set the OVP (overvoltage protection) trip point.  
If the output voltage exceeds a set value due to inadvertent operation or failure, this function shuts off the POWER switch to protect the load. For information on performing this setting, see 3.2.1 "OVP (overvoltage protection) trip point presetting".
- 17** **VOLTAGE CHECK terminals**  
These terminals are used to check the output voltage from the front panel by connecting a digital voltmeter (DVM). The unit incorporates a 0.1 A output fuse to guard against short-circuiting of these terminals.  
The voltage check chips supplied are used to connect an external DVM.
- 18** **Casters**  
The casters on the front panel side of the TYPE IV and TYPE V models are provided with a locking mechanism. For information on locking the casters, see 1.2 "Installation".
- 19** **Stopper bolts (TYPE III and TYPE V models only)**  
These are used to lock the unit at an installation site. For information on locking the unit, see 1.2 Installation.  
The TYPE IV models do not have stopper bolts.
- 20** **O.V.P PRESET switch (TYPE V models only)**  
The voltmeter indicates the OVP set value when this switch is held down.  
This switch is not provided for TYPE III and TYPE IV models.

## 5.2 Rear panel

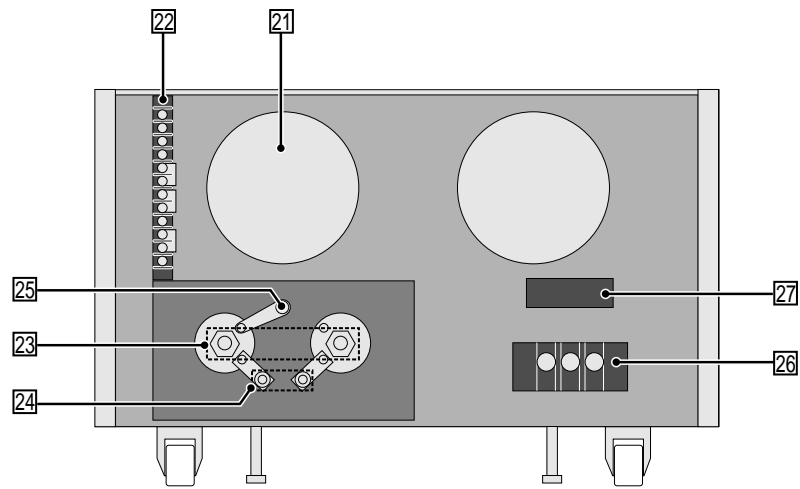

Fig. 5-4 PAD-L series TYPE III models rear panel

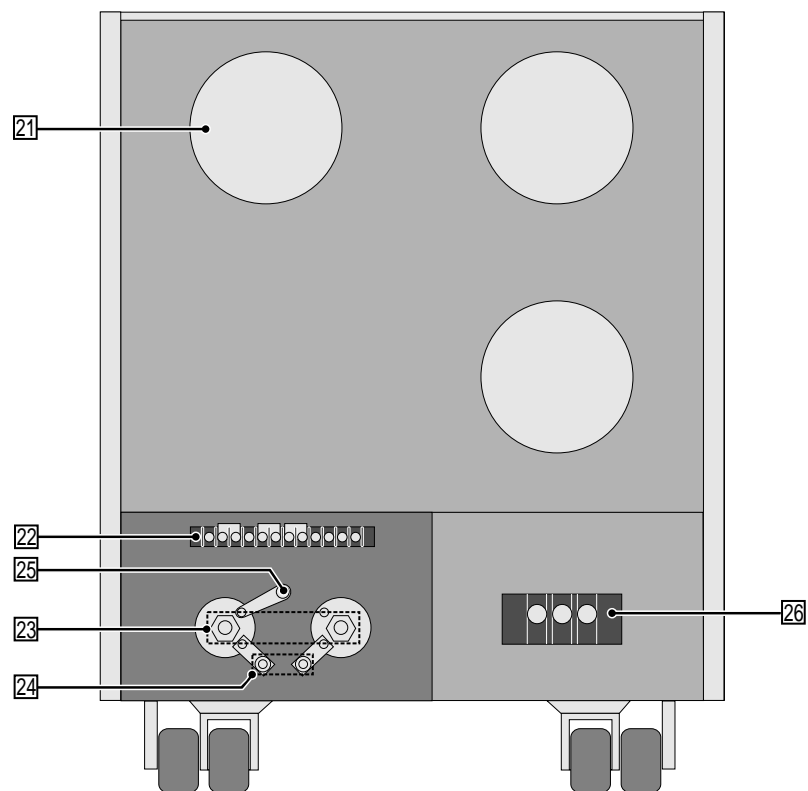

Fig. 5-5 PAD-L series TYPE IV models rear panel  
(except PAD250-15L)

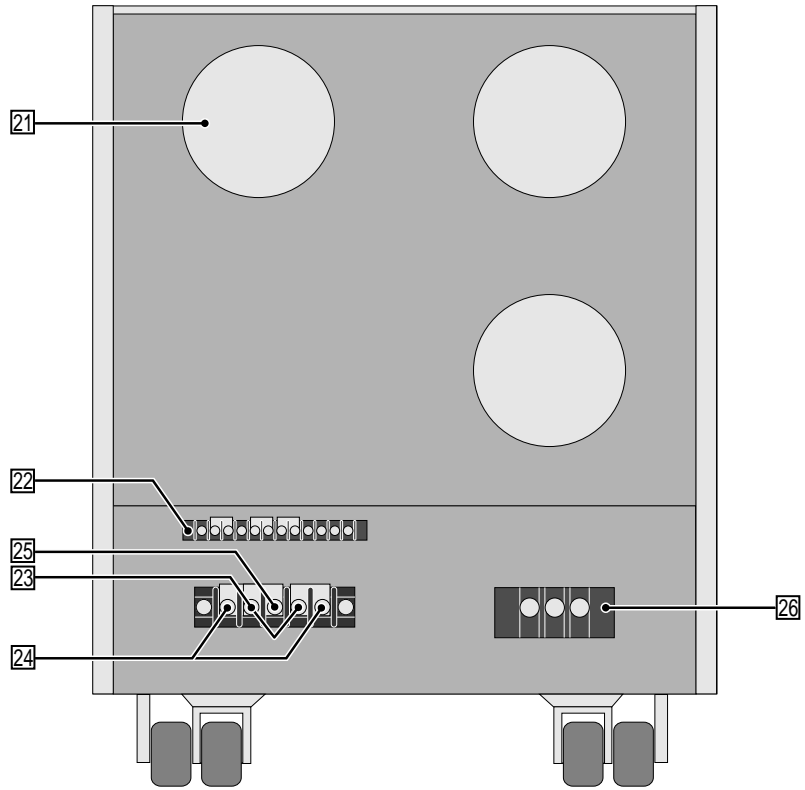

Fig. 5-6 PAD-L series PAD250-15L rear panel

## Rear panel (continued)

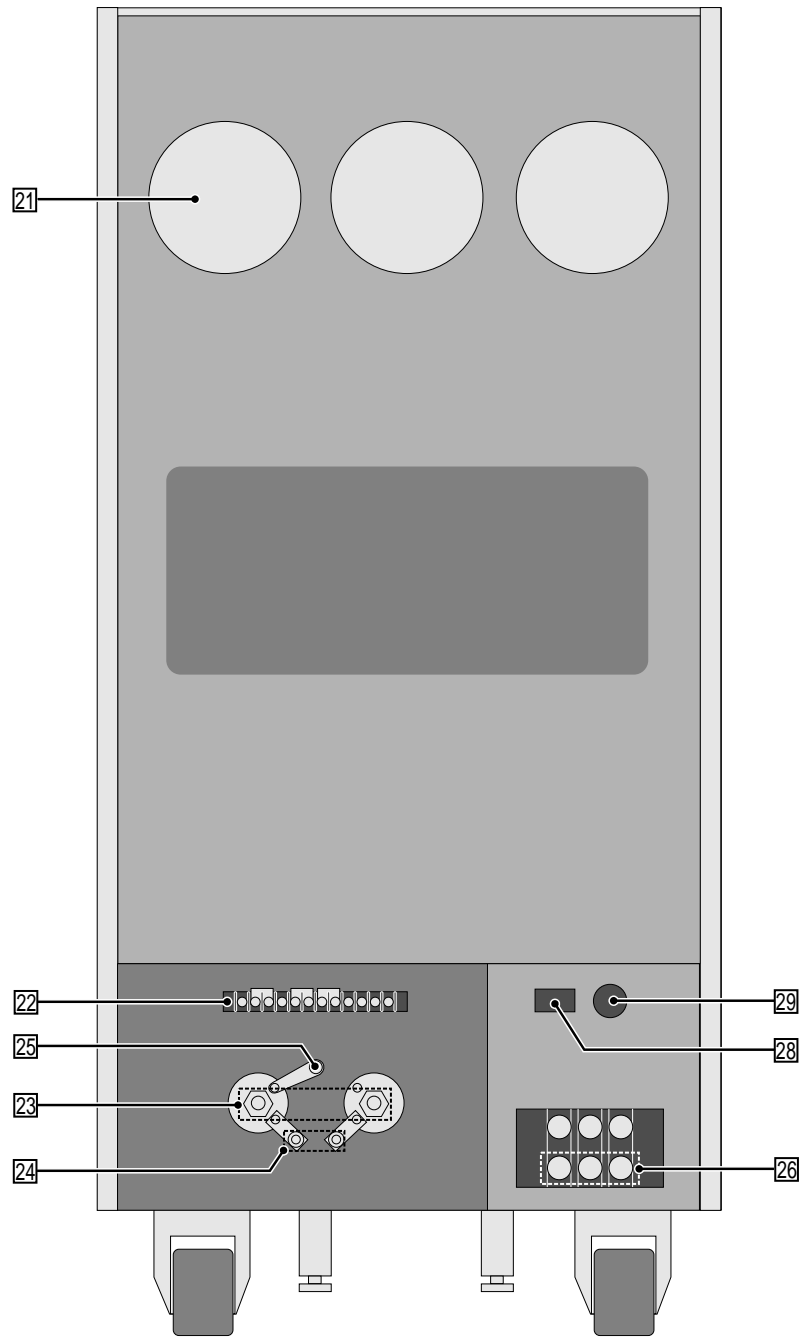

Fig. 5-7 PAD-L series TYPE V models rear panel (except PAD110-60L)

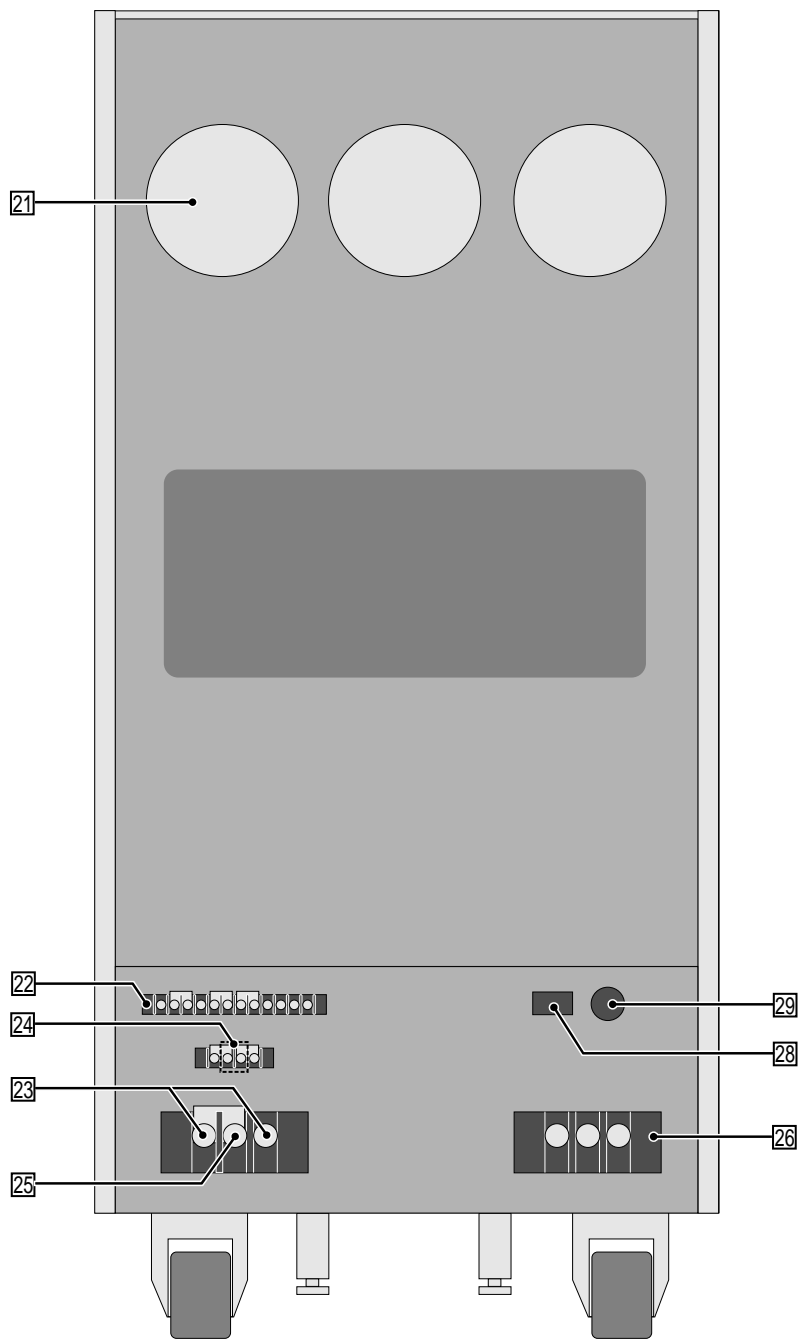

Fig. 5-8 PAD-L series PAD110-60L rear panel

---

## Rear panel (continued)

### 21 Exhaust ports

This port uses a fan to exhaust heated air from inside. Keep sufficient space around the unit for good ventilation.

### 22 Control terminal board

This is the terminal board used for applied operations such as remote control.

In general, connect terminals 0 and 1, terminals 3 and 4, and terminals 5 and 6 using the shorting bars.

Terminal board screw size: M3

---

**⚠ WARNING** • **Incorrect handling may cause electric shock. For details, see Chapter 4 "Applied Operation".**

---

### 23 Output terminals

Output is taken from these terminals. The size of the terminals varies by model, as follows:

- TYPE III models: M10 bolt
- TYPE IV models: M10 bolt (PAD250-15L: M5 screw)
- TYPE V models: M12 bolt (PAD110-60L: M6 screw)

---

**⚠ WARNING** • **To avoid electric shock, always turn off the POWER switch whenever it is necessary to touch the terminals.**

---

### 24 Sensing terminals

This is used for the remote sensing function.

It is indicated as SAMPLING or +S and -S on the panel, depending on the model.

These terminals are referred to as sensing terminals in this Operation Manual.

For more information on their use, see 4.1 "Remote sensing".

---

**⚠ WARNING** • **To avoid electric shock, always turn off the POWER switch whenever it is necessary to touch the terminals.**

**⚠ CAUTION** • **Do not connect the load directly to the sensing terminals.**

---



---

## 25 GND (Chassis ground) terminal

This terminal is connected to the unit chassis. In general, it should be connected to the + (pos.) or - (neg.) terminal using a shorting bar. For chassis ground terminal, see 2.6 "Grounding the output terminal".

## 26 AC input terminal board

Provides AC power input terminals. The screw size of the terminals varies by model, as follows:

- TYPE III models: M5 screw
- TYPE IV models: M5 screw
- TYPE V models: M8 screw (PAD110-60L: M6 screw)

- 
- ⚠ WARNING**
- **Incorrect handling may cause electric shock. Always follow the instructions in section 1.5 "Connecting the AC power cord".**
  - **Make sure that the ground terminal is securely grounded. For details, see section 1.6 "Grounding".**
- 

## 27 Input voltage mark-plate (TYPE III models only)

This plate indicates the AC input voltage.

- 
- ⚠ CAUTION**
- **The TYPE III models allow the modification of the AC input voltage by modifying the wiring of the main power transformer inside the unit. (200 V or 100 V)**
- After the AC input voltage is changed, the input voltage must agree with the voltage indicated on the input voltage mark-plate. For more information, see 1.4 "Changing the input power voltage".**
- 

## 28 AC outlet (TYPE V models only)

Provides an output voltage of 100 V AC, 1 A.

## 29 Fuse holder (TYPE V models only)

Intended for the power outlet, this contains a 1 A output fuse.

Replaceable fuse: 1 A, 250 V, Slow blow type,  $\phi 6.4 \times 31.8$  mm



# 6

## Chapter 6 Maintenance

To maintain the unit's original performance as long as possible, conduct periodic checks and maintenance.

---

## 6.1 Cleaning

When the panel gets soiled, wet a piece of soft cloth with a water-diluted neutral detergent, and wipe the panel softly.

- 
- ⚠ WARNING**
- For maintenance work, always turn off the **POWER** switch and the switch on the switchboard.
  - Do not use volatile solvents such as thinner and benzine. They may discolor the unit surface coating, erase printed characters, or make face of indicator opaque.
- 

## 6.2 Inspection

To purchase accessories, contact Kikusui distributor/agent.

### ■ AC power cord

Check that there is no damage on the insulation coating.

- 
- ⚠ WARNING**
- Breaks in the insulation coating may cause electric shock. If a break is found, immediately stop using the unit.
-

---

## 6.3 Adjustment

Before shipment, the PAD-L series is thoroughly adjusted. After an extended period of use, however, the power supply will require regular adjustment.

To have adjustment performed, you may contact Kikusui distributor/agent. If you wish to adjust the power supply on your own, follow the steps below.

- 
- ⚠ WARNING** • To adjust the unit, remove the external cover and adjust the variable resistors inside. Note that operating the unit with the cover removed increases the risk of electric shock.
- Unit adjustments must be performed by qualified personnel having sufficient expertise and familiarity with the adjustment procedure and safety considerations**
- 

### 6.3.1 Test equipment required

For adjustment, the following equipment is necessary.

- DC voltmeter (DVM) with measuring accuracy of 0.2% or better.
- Shunt resistor with accuracy of 0.2% or better (with enough capacity to apply a rated output current for the PAD-L series to be adjusted.)

### 6.3.2 Environment

Conduct adjustment under the following ambient conditions.

- Ambient temperature:  $23^{\circ}\text{C} \pm 5^{\circ}\text{C}$
- Ambient humidity: 80% RH or less

To minimize adjustment errors due to an initial drift, warm up the power supply for at least 30 minutes before starting adjustment. Also warm up the DVM and shunt resistor for a necessary period of time.

### 6.3.3 Removing the cover



#### WARNING

- For maintenance work, always turn off the POWER switch and the switch on the switchboard.
- Never attempt to touch the inside of the unit immediately after shutting off power. Immediately after power is shut off, a large-capacity capacitor in the rectifier circuit retains energy levels hazardous to the human body. It takes 30 seconds or more seconds for this energy to dissipate to safe levels.

#### ■ Removing the cover from the TYPE III model

Remove the top cover, then the side cover on the right side of the unit (viewed from the front). See Fig. 6-1.

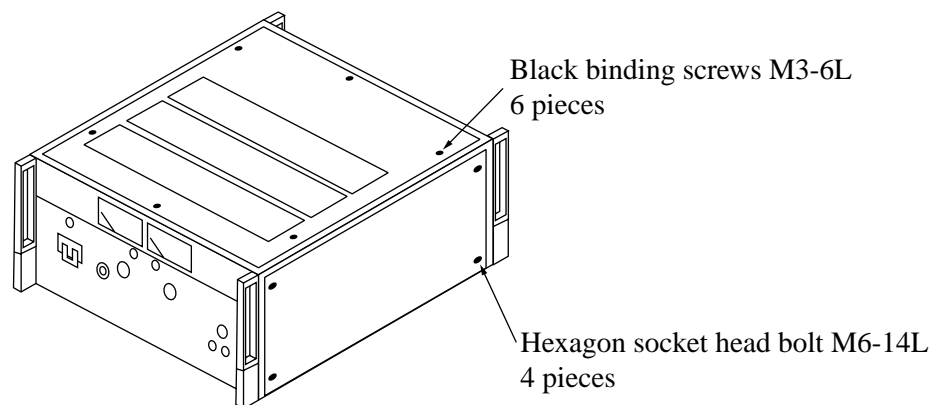

Fig. 6-1 Removing the cover from the TYPE III model

### ■ Removing the cover from the TYPE IV model

Remove the top cover, then the side cover on the right side of the unit (viewed from the front). See Fig. 6-2.

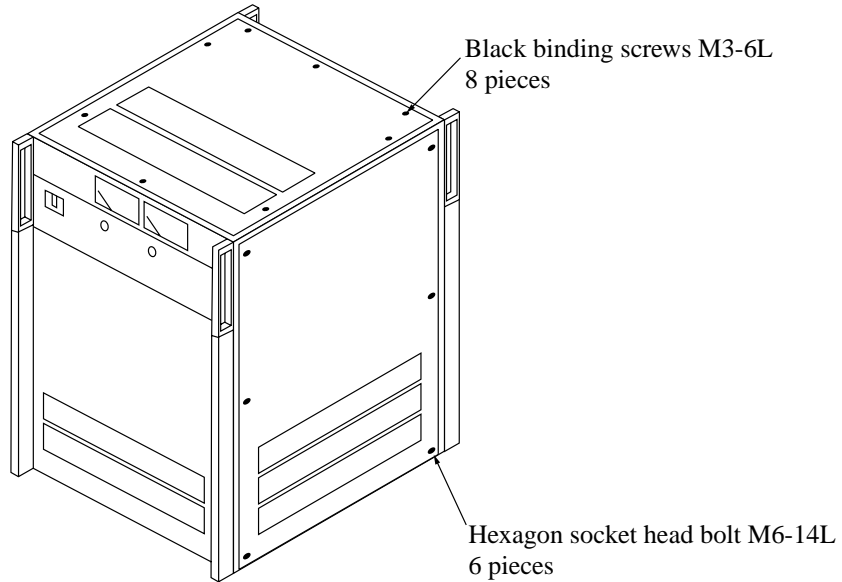

Fig. 6-2 Removing the cover from the TYPE IV model

### ■ Removing the cover from the TYPE V model

Remove the top cover only. See Fig. 6-3.

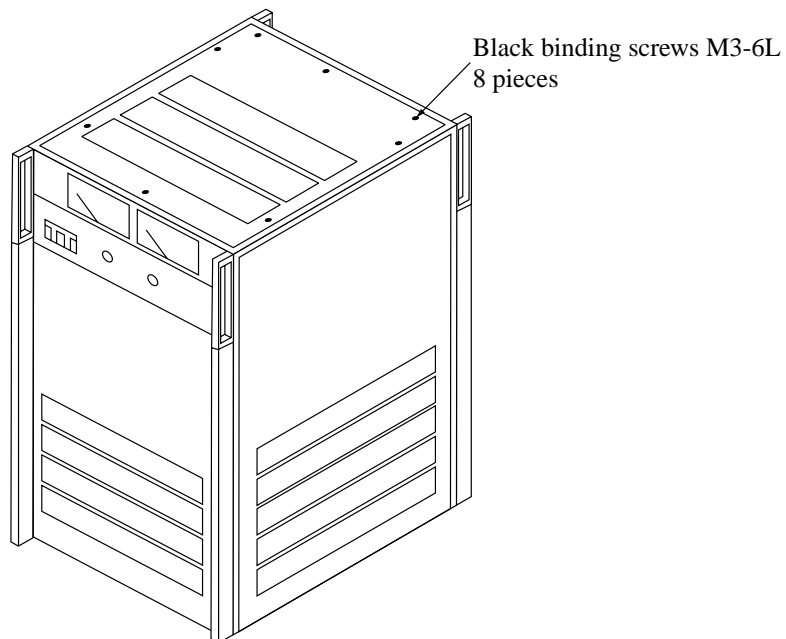

Fig. 6-3 Removing the cover from the TYPE V model

## 6.3.4 Adjustment procedure

Adjustment items can be roughly classified into two areas: the voltage system and the current system.

Use variable resistors on the front panel and the variable resistors on the internal PCB A-200 to perform adjustments.

**NOTE**

- Variable resistors other than those on the front panel and those on the PCB A-200 should not be adjusted by the user. Do not disturb the settings of these variable resistors.

If you inadvertently disturb the settings of any variable resistor other than those that are user-adjustable, it must be readjusted. Contact Kikusui distributor/agent.

### Voltage system adjustment procedure

The voltage system adjustment includes the following five related items. Adjust them as follows:

- Mechanical zero of the voltmeter
- Output voltage offset
- Maximum variable range of constant voltage
- Full scale of voltmeter
- Voltage limit

#### ■ Connection of equipment

1. Turn off the POWER switch.
2. Connect a DVM to output terminals as shown in Fig. 6-4.  
Connect the GND terminal and the - (neg.) terminal with the shorting bar.

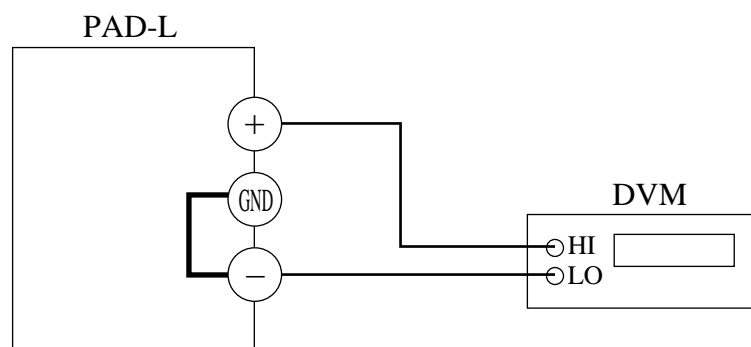

Fig. 6-4 Connection for voltage system adjustment



---

## ● Mechanical zero of the voltmeter

3. Check that the POWER switch is OFF.

Mechanical zero adjustment is carried out with the POWER switch turned OFF.

4. Set the voltmeter pointer to "0" using the voltmeter zero-adjustment.

The voltmeter zero-adjustment is located below the voltmeter for TYPE III and IV models and in the voltmeter for TYPE V models.

## ■ Warm-up

- 
- ⚠ CAUTION** • Perform the warm-up with the cover in place. Applying power to the unit for extended periods with the cover removed weakens the cooling effect, potentially causing a failure.
- 

5. Turn on the POWER switch.

6. Set the output voltage to the rated output voltage.

Warm up the unit, including the DVM, for an adequate period.

## ■ Removing the cover

7. Turn off the POWER switch, then turn off the switch for the switchboard.

8. Remove the cover. See 6.3.3 "Removing the cover".

## ● Output voltage offset

- 
- NOTE** • On shipment from the factory, the output voltage offset is set so that a slight negative voltage (approximately 0.2% of the rated voltage) is generated when the V.os variable resistor is turned to the extreme counterclockwise position, in order to ensure 0 V output. If this voltage does not present problems, turn the V.os variable resistor on the front panel to the extreme counterclockwise position and proceed to the next adjustment item.
- 

9. Turn on the switch for the switchboard, then turn on the POWER switch.

10. Turn the VOLTAGE setting knob to the extreme counterclockwise position.

11. Adjust the V.os variable resistor on the front panel so that the DVM displays 0 V.

## ● Maximum variable range of constant voltage

12. Turn the VOLTAGE setting knob to the extreme clockwise position.

13. Adjust the RV20 variable resistor on the PCB A-200 so that the DVM reading becomes the maximum voltage value shown in Table 6-1.

See Figs. 6-5, 6-6, and 6-7.

## Voltage system adjustment procedure (continued)

### ● Full scale of the voltmeter

14. Set the output voltage so that the DVM displays the rated output voltage of the unit.
15. Adjust the  $V_{FS}$  variable resistor on the front panel so that the indication of the unit's voltmeter matches the DVM reading.

### ● Voltage limit

16. Adjust the RV9 variable resistor on the PCB A-200 so that the unit voltmeter indication is the same when the CURRENT/VOLT. LIMIT switch is held down and released.

See Figs. 6-5, 6-6, and 6-7.

This completes the voltage system adjustment.

Table 6-1 Maximum voltage value

Type III	PAD 16-100L	PAD 35-50L	PAD 35-60L	PAD 60-35L	PAD 110-20L	PAD 250-8L
Maximum voltage [V]	16.5	35.6	35.6	61	112	260

Type IV	PAD 35-100L	PAD 60-60L	PAD 110-30L	PAD 250-15L
Maximum voltage [V]	35.6	61	115	260

Type V	PAD 35-200L	PAD 60-120L	PAD 110-60L
Maximum voltage [V]	35.6	61	115

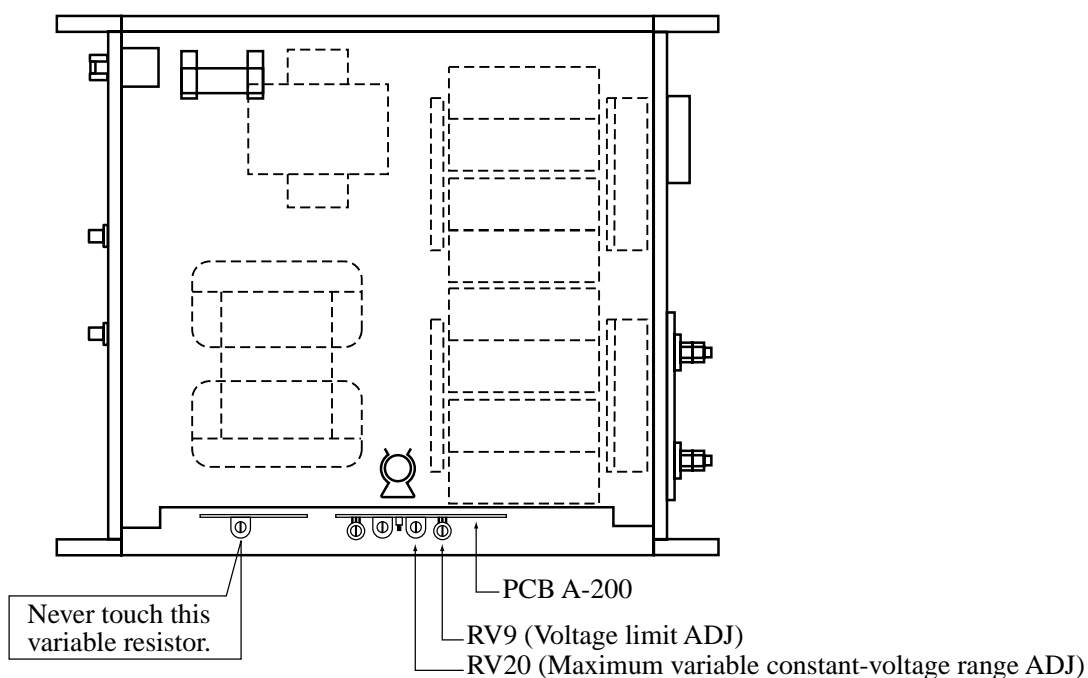

Fig. 6-5 RV9 and RV20 in the TYPE III model

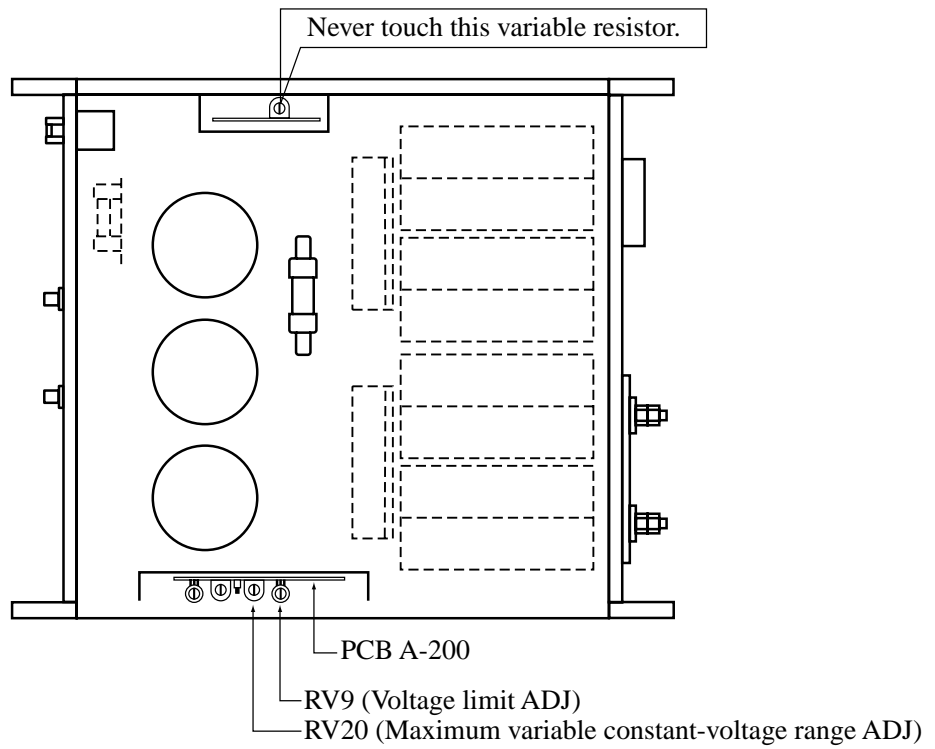

Fig. 6-6 RV9 and RV20 in the TYPE IV model

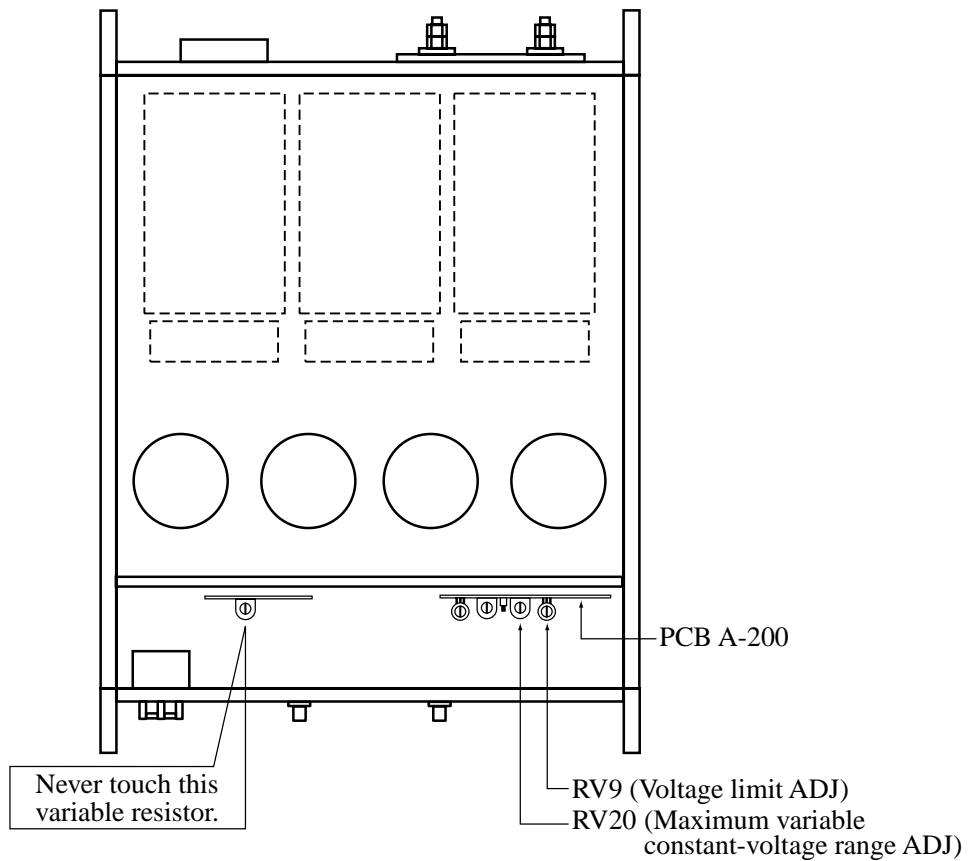

Fig. 6-7 RV9 and RV20 in the TYPE V model

## Current system adjustment procedure

The current system adjustment includes the following five related items. Adjust them as follows:

- Mechanical zero of the ammeter
- Output current offset
- Maximum variable range of constant current
- Full scale of ammeter
- Current limit

### ■ Connection of equipment

1. Turn off the POWER switch.
2. Connect a shunt resistor and DVM to output terminals as shown in Fig. 6-8.

Connect the GND terminal and the - (neg.) terminal with the shorting bar.

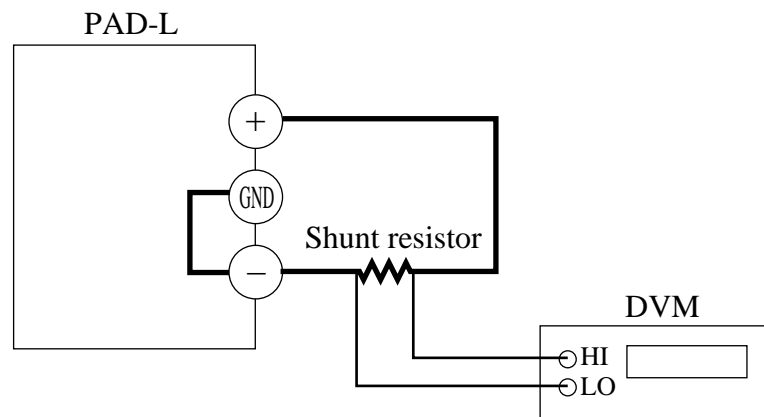

Fig. 6-8 Connection for current system adjustment

### ● Mechanical zero of the ammeter

3. Check that the POWER switch is OFF.  
Mechanical zero adjustment is carried out with the POWER switch turned OFF.
4. Set the ammeter pointer to "0" using the ammeter zero-adjustment.  
The ammeter zero-adjustment is located below the ammeter for TYPE III and IV models and in the ammeter for TYPE V models.

---

## ■ Warm-up

- 
- ⚠ CAUTION** • Perform the warm-up with the cover in place. Applying power to the unit for extended periods with the cover removed weakens the cooling effect, potentially causing a failure.
- 

5. Turn on the POWER switch.
6. Set the output current to the rated output current.  
Warm up the unit, including the DVM, for an adequate period.

## ■ Removing the cover

7. Turn off the POWER switch, then turn off the switch for the switchboard.
8. Remove the cover. See 6.3.3 "Removing the cover".

## ● Output current offset

- 
- NOTE** • On shipment from the factory, the output current offset is set so that a slight negative current (several tens mA) flows when the I.os variable resistor is turned to the extreme counterclockwise position, in order to ensure 0 A output. If this current does not present problems, turn the I.os variable resistor on the front panel to the extreme counterclockwise position and proceed to the next adjustment item.
- 

9. Turn on the switch for the switchboard, then turn on the POWER switch.
10. Turn the CURRENT setting knob to the extreme counterclockwise position.
11. Adjust the I.os variable resistor on the front panel so that a current value calculated from the DVM reading becomes 0 A.

## ● Maximum variable range of constant current

12. Turn the CURRENT setting knob to the extreme clockwise position.
13. Adjust the RV49 variable resistor on the PCB A-200 so that a current value calculated from the DVM reading becomes the maximum current value shown in Table 6-2.  
See Figs. 6-9, 6-10, and 6-11.

## ● Full scale of the ammeter

14. Set the output current so that a current value calculated from the DVM reading equals the rated output current of the unit.
15. Adjust the A.FS variable resistor on the front panel so that the indication of the unit's ammeter equals a current value calculated from the DVM reading.

## Current system adjustment procedure (continued)

### ● Current limit

16. Adjust the RV53 variable resistor on the PCB A-200 so that the unit ammeter indication is the same when the CURRENT/VOLT. LIMIT switch is held down and released.

See Figs. 6-9, 6-10, and 6-11.

This completes the current system adjustment.

Table 6-2 Maximum current value

Type III	PAD 16-100L	PAD 35-50L	PAD 35-60L	PAD 60-35L	PAD 110-20L	PAD 250-8L
Maximum current [V]	105	51	61	36	20.5	8.2

Type IV	PAD 35-100L	PAD 60-60L	PAD 110-30L	PAD 250-15L
Maximum current [V]	105	61	30.5	15.5

Type V	PAD 35-200L	PAD 60-120L	PAD 110-60L
Maximum current [V]	205	125	62

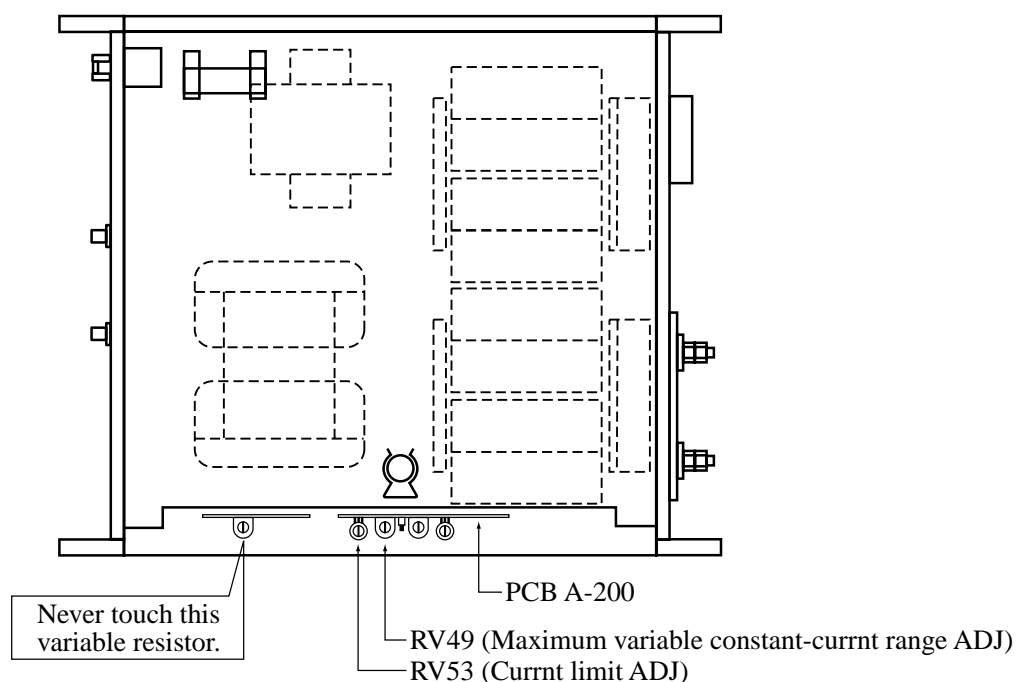

Fig. 6-9 RV49 and RV53 in the TYPE III model

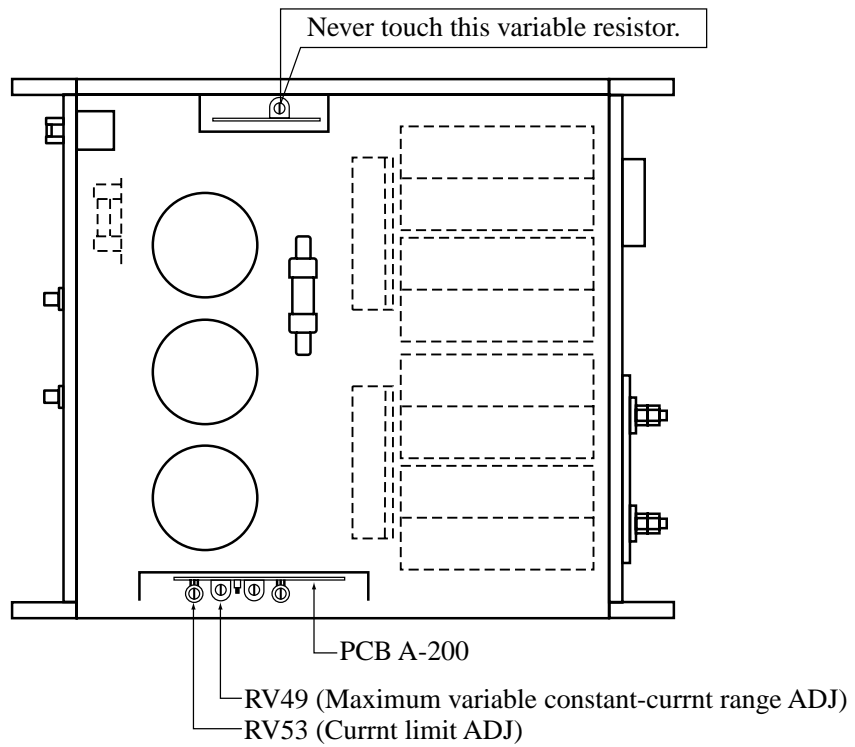

Fig. 6-10 RV49 and RV53 in the TYPE IV model

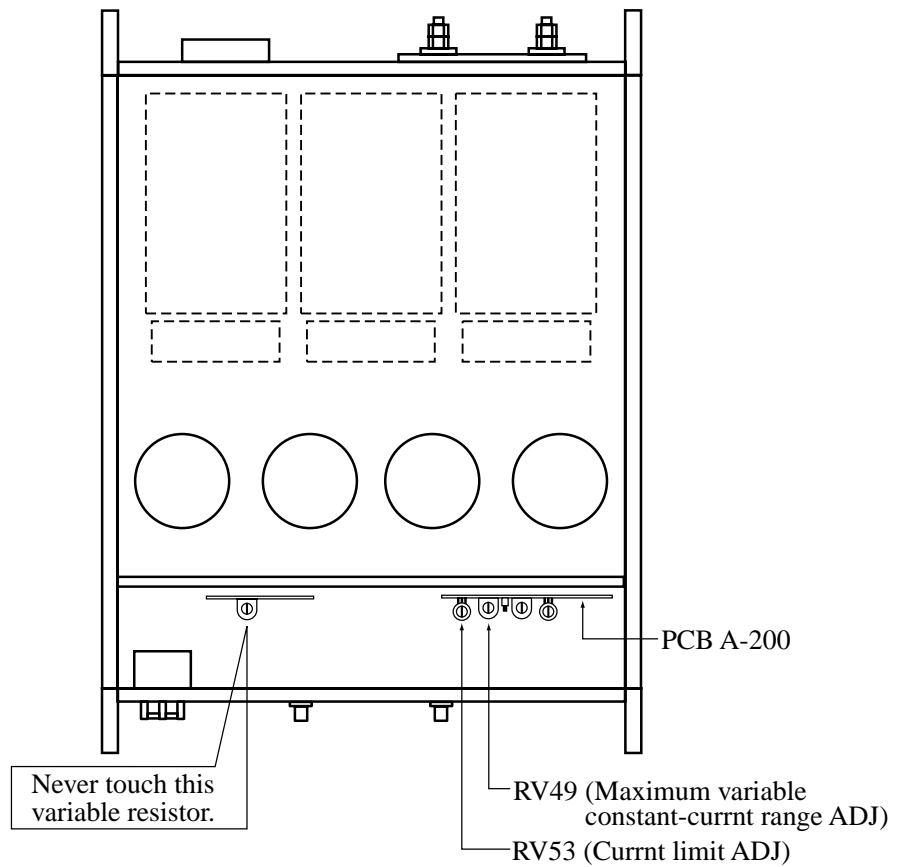

Fig. 6-11 RV49 and RV53 in the TYPE V model

## 6.4 Replacing the input fuse (TYPE III and TYPE IV models only)

TYPE III and TYPE IV models contain a spare input fuse to allow replacement by the user if the input fuse blows.

The input fuse cannot be replaced by the user for TYPE V models. Contact Kikusui distributor/agent for replacement.

- 
- ⚠ WARNING**
- Replacement of the input fuse requires removal of the external cover from the unit. This work must be carried out by qualified personnel having sufficient expertise and familiarity with the procedure and the relevant safety considerations.
  - For maintenance work, always turn off the POWER switch and the switch on the switchboard.
  - Never attempt to touch the inside of the unit immediately after shutting off power. Immediately after power is shut off, a large-capacity capacitor in the rectifier circuit retains energy levels hazardous to the human body. It takes 30 seconds or more seconds for this energy to dissipate to safe levels.
- 

### Replacing an input fuse for TYPE III models

1. Remove the top cover from the unit. See Fig. 6-12.

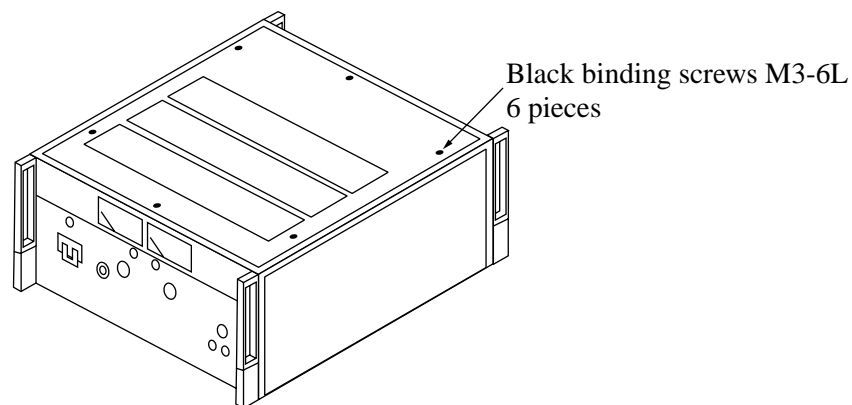

Fig. 6-12 Removing the top cover from the TYPE III model



2. Remove the input fuse from the fuse holder and replace with a new fuse. See Fig. 6-13.

Select an input fuse with a rating adequate to the input power voltage range.

Table 6-3

Input fuse	PAD 16-100L	PAD 35-50L	PAD 35-60L	PAD 60-35L	PAD 110-20L	PAD 250-8L
For 200 V	30 A					
For 100 V	50 A		60 A		50 A	

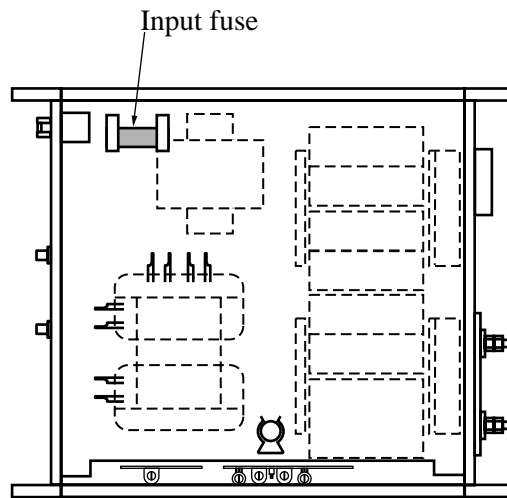

Fig. 6-13 Replacing an input fuse for the TYPE III model

3. Replace the top cover.

## Replacing an input fuse for TYPE IV models

1. Remove the front cover from the unit. See Fig. 6-14.

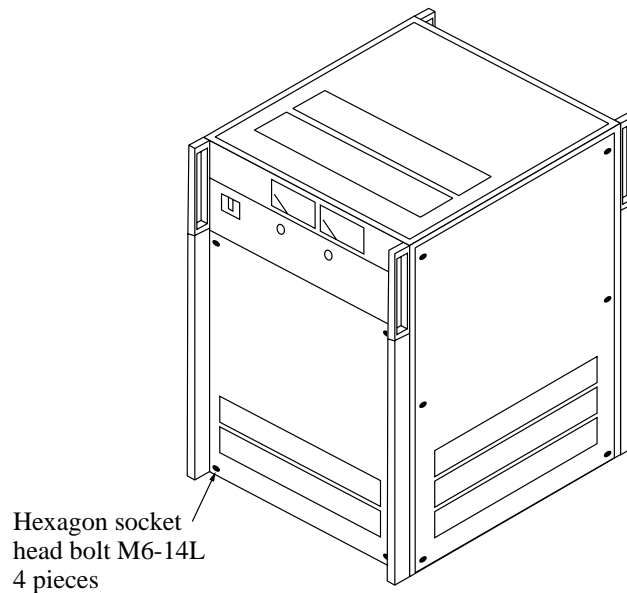

Fig. 6-14 Removing the front cover from the TYPE IV model

2. Remove the input fuse from the fuse holder and replace with a new fuse. See Fig. 6-15.

Select an input fuse with a rating adequate to the input power voltage range.

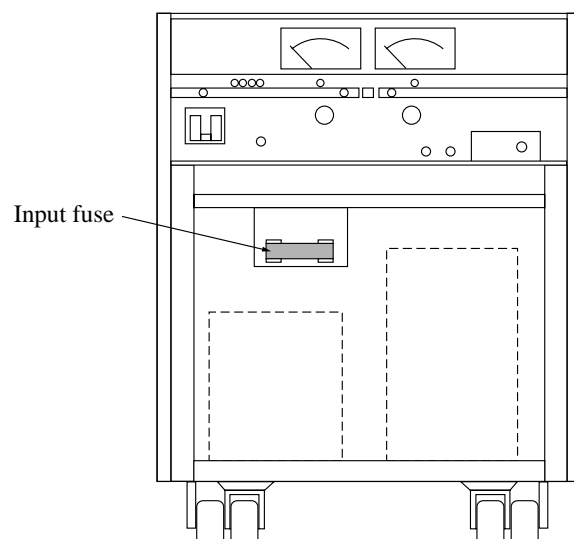

Fig. 6-15 Replacing an input fuse for the TYPE IV model

3. Replace the front cover.

## 6.5 Malfunctions and Causes

This section describes some symptoms of possible malfunctions encountered during use of the unit, along with appropriate remedies.

Here, we provide five typical symptoms and possible check items for each; you simply find the relevant item. Ideally, you will be able to cure these symptoms without difficulty.

When you find a relevant item, follow the corresponding remedy. If this does not solve or improve the problem, or if no relevant item can be located, please contact Kikusui distributor/agent.

For inquiries, use the follow-up sheets at the end of this Operation Manual.

### Symptom 1: The POWER switch is shut off after being turned on.

Check item	Possible cause and remedy
<input type="checkbox"/> The overvoltage protection circuit has been tripped.	<ul style="list-style-type: none"> <li>The set voltage for overvoltage protection is too low with respect to the output voltage.</li> </ul>
<input type="checkbox"/> The shorting bar connecting terminals 0 and 1 or terminals 3 and 4 of the control terminal board has been removed or is loose.	<ul style="list-style-type: none"> <li>Install the shorting bars properly.</li> </ul>
<input type="checkbox"/> The fan has stopped.	<ul style="list-style-type: none"> <li>The temperature protection circuit has been tripped. The fan needs to be replaced.</li> </ul>
<input type="checkbox"/> The AC line voltage is extremely distorted.	<ul style="list-style-type: none"> <li>Connect the unit to another line of the switchboard.</li> </ul>
<input type="checkbox"/> None of the above	<ul style="list-style-type: none"> <li>The protective circuit has been tripped due to a failure of the rectifier circuit.</li> </ul>

### Symptom 2: No output at all, or output by only a small amount

Check item	Possible cause and remedy
<input type="checkbox"/> The input fuse is blown.	<ul style="list-style-type: none"> <li>The input voltage is too high. In this case, an internal part may be damaged, requiring repair. Contact Kikusui distributor/agent.</li> </ul>
<input type="checkbox"/> The lamp has gone off.	<ul style="list-style-type: none"> <li>A break in the AC power cord</li> </ul>
<input type="checkbox"/> Lamps turn on and off in sequence, causing the operation range to shift.	<ul style="list-style-type: none"> <li>The constant voltage or constant current setting range is too narrow.</li> </ul>
<input type="checkbox"/> The shorting bar connecting terminals 5 and 6 of the control terminal board has been removed or is loose.	<ul style="list-style-type: none"> <li>Install the shorting bar properly.</li> </ul>
<input type="checkbox"/> The output fuse has been blown.	<ul style="list-style-type: none"> <li>A current exceeding the rated value may have flowed.</li> </ul>
<input type="checkbox"/> A current flows even when no load is connected.	<ul style="list-style-type: none"> <li>The protective diode inserted in parallel to the output is defective. Connecting a battery to the opposite polarity will burn out the diode.</li> </ul>
<input type="checkbox"/> None of the above	<ul style="list-style-type: none"> <li>A defective circuit</li> </ul>

### Symptom 3: Excessive output is produced.

Check item	Possible cause and remedy
<input type="checkbox"/> The shorting bar connecting terminals 3 and 4 of the control terminal board has been removed or is loose.	<ul style="list-style-type: none"> <li>• Install the shorting bar properly.</li> </ul>
<input type="checkbox"/> The output voltage (current) does not fall.	<ul style="list-style-type: none"> <li>• Defective power transistor</li> <li>• Failed breeder circuit</li> </ul>
<input type="checkbox"/> None of the above	<ul style="list-style-type: none"> <li>• Failed OVP circuit</li> </ul>

### Symptom 4: Unstable output

Check item	Possible cause and remedy
<input type="checkbox"/> The shorting bar connecting the sensing terminals has been removed or is loose.	<ul style="list-style-type: none"> <li>• Install the shorting bar properly.</li> </ul>
<input type="checkbox"/> The shorting bar connecting terminals of the control terminal board has been removed or is loose.	<ul style="list-style-type: none"> <li>• Install the shorting bar properly.</li> </ul>
<input type="checkbox"/> Is the input power voltage normal?	<ul style="list-style-type: none"> <li>• Beyond the input voltage range</li> </ul>
<input type="checkbox"/> A special load has been connected.	<ul style="list-style-type: none"> <li>• See 2.3 "Load".</li> </ul>
<input type="checkbox"/> A drift results in problems.	<ul style="list-style-type: none"> <li>• Perform a warm-up for at least 30 minutes.</li> </ul>
<input type="checkbox"/> Oscillating	<ul style="list-style-type: none"> <li>• Phase rotation has occurred due to wiring for remote sensing. Connect an electrolytic capacitor to the load ends. See 4.1 "Remote sensing".</li> </ul>
<input type="checkbox"/> None of the above	<ul style="list-style-type: none"> <li>• Circuit failure</li> </ul>

### Symptom 5: Large ripple voltage

Check item	Possible cause and remedy
<input type="checkbox"/> Is the input power voltage normal?	<ul style="list-style-type: none"> <li>• Input voltage is too low.</li> </ul>
<input type="checkbox"/> The sensing terminals have been floated from the output terminals.	<ul style="list-style-type: none"> <li>• Firmly connect the sensing terminals.</li> </ul>
<input type="checkbox"/> A strong magnetic field or electric field generating source is located nearby.	<ul style="list-style-type: none"> <li>• Affected by electromagnetic induction. Move the unit and load away from the magnetic field or electric field generating source. Twist the load wires together.</li> </ul>
<input type="checkbox"/> None of the above	<ul style="list-style-type: none"> <li>• Circuit failure</li> </ul>

# 7

## Chapter 7 Specifications

This chapter provides the electrical and mechanical specifications for the PAD-L series, as well as a list of accessories.

## 7.1 TYPE III models specifications

Unless otherwise specified, the specifications of the unit are based on the following conditions.

- The load is a pure resistance.
- The - (neg.) output terminal is connected to the GND terminal.
- The unit should be used after 30 minutes warming-up time.

Standard value and theoretical value do not guarantee performance. They should be referred to as target values only.

Type III		PAD 16-100L	PAD 35-50L	PAD 35-60L	PAD 60-35L	PAD 110-20L	PAD 250-8L
Input							
Input voltage and frequency		200/100 VAC $\pm$ 10 %, 50/60 Hz, 1 (Changeable by wiring terminals of the main power transformer)					
Power consumption, at 200VAC, rated load		Approx. 3.3 kVA	Approx. 3.3 kVA	Approx. 3.8 kVA	Approx. 3.4 kVA	Approx. 3.8 kVA	Approx. 3.4 kVA
Output							
Voltage	Rated voltage	16 V	35 V	35 V	60 V	110 V	250 V
	Variable range	0 to 16V	0 to 35 V	0 to 35 V	0 to 60 V	0 to 110 V	0 to 250 V
	Resolution (theoretical value) *1	3 mV	6.3 mV	6.3 mV	11 mV	20 mV	45 mV
	Number of turns of panel control	10 turns					
Current	Rated current	100 A	50 A	60 A	35 A	20 A	8 A
	Variable range	0 to 100 A	0 to 50 A	0 to 60 A	0 to 35 A	0 to 20 A	0 to 8 A
	Resolution (theoretical value) *1	47 mA	140 mA	170 mA	120 mA	68 mA	27 mA
	Number of turns of panel control	1 turn *4	1 turn				
Constant voltage characteristics							
Ripple and noise (5Hz to 1MHz) RMS		0.5 mV	0.5 mV	0.5 mV	0.5 mV	1 mV	5 mV
Source effect (to $\pm$ 10% of AC input voltage) *2		0.005%+1mV	0.005%+1mV	0.005%+1mV	0.005%+1mV	0.005%+1mV	+2mV
Load effect (to 0 to 100% of output current) *2		0.005%+2mV	0.005%+2mV	0.005%+2mV	0.005%+2mV	0.005%+2mV	+3mV
Transient response (standard value) *2, *3		50 $\mu$ s					
Temperature coefficient (standard value)		50 ppm/					
Constant current characteristics							
Ripple and noise (5Hz to 1MHz) RMS		100 mA	10 mA	10 mA	8 mA	4 mA	4 mA
Source effect (to $\pm$ 10% of AC input voltage)		3 mA	3 mA	3 mA	3 mA	1 mA	1 mA
Load effect (to 0 to 100% of output voltage)		5 mA	5 mA	5 mA	3 mA	3 mA	3 mA
Constant voltage operation indication		C.V, green lamp indication					
Constant current operation indication		C.C, red lamp indication					

\*1: The value is calculated from the number of turns of the wire to wound potentiometer. In practice, use 3 to 5 times each value as a target.

\*2: Measured using the remote sensing function.

\*3: Time necessary for output voltage to return to  $\pm$  (0.05%+10mV) max. of rated value at 5 to 100% changes of output current.

\*4: 1 turn, both of coarse and fine adjustment

Type III		PAD 16-100L	PAD 35-50L	PAD 35-60L	PAD 60-35L	PAD 110-20L	PAD 250-8L
Range of operation temperature and humidity		0 to 40 / 10 to 90 %RH (no dew condensation allowed)					
Range of storage temperature and humidity		-10 to 60 / 0 to 70 %RH (no dew condensation allowed)					
Cooling system		Forced air cooling with fan					
Output polarity		Positive or negative grounding possible					
Isolation voltage		± 250 V	± 250 V	± 250 V	± 250 V	± 250 V	± 500 V
Insulation resistance							
Across chassis and input terminals		500VDC, 30M min.					
Across chassis and output terminals		500VDC, 20M min.					
Withstanding voltage							
Across input terminals and output terminals		Should withstand 1500 VAC, 1 min. with no abnormalities					
Across input terminals and chassis							
Meter display							
Voltmeter	Full scale, Class 2.5 (JIS)	16 V	35 V	35 V	60 V	110 V	250 V
Ammeter	Full scale, Class 2.5 (JIS)	110 A	60 A	60 A	35 A	22 A	8 A
Remote control							
Output voltage/control voltage ratio		16 V / approx. 10 V	35 V / approx. 10 V	35 V / approx. 10 V	60 V / approx. 10 V	110 V / approx. 10 V	250 V / approx. 10 V
Output voltage/control resistance ratio		16 V / approx. 10k	35 V / approx. 10k	35 V / approx. 10k	60 V / approx. 10k	110 V / approx. 10k	250 V / approx. 10k
Output current/control voltage ratio		100 A / approx. 0.3 V	50 A / approx. 0.5 V	60 A / approx. 0.5 V	35 A / approx. 1.16V	20 A / approx. 1.0 V	8 A / approx. 0.8 V
Output current/control resistance ratio		100 A / approx. 550	50 A / approx. 1k	60 A / approx. 1k	35 A / approx. 1k	20 A / approx. 1k	8 A / approx. 1k
Remote sensing		Possible (compensation one way approx. 1.2 V max.)					
Master-slave-control parallel operation		Possible					
Master-slave-control series operation		Possible					
Protective circuit							
Operation		POWER switch is turned off.					
Trip temperature of thermal protector		100 /120	100	100	100	100	100
Over voltage protection (OVP)	Voltage setting range (standard value)	6 to 18 V	6 to 38 V	6 to 38 V	7 to 66 V	20 to 129 V	50 to 280 V
	Trigger pulse width (standard value)	50 ms					
Input fuse rating	At 200 VAC source	30 A					
	At 100 VAC source	50 A	50 A	60 A	50 A	50 A	50 A
Output fuse rating		100 A	50 A	60 A	40 A	20 A	10 A
Weight		Approx. 63 kg	Approx. 58 kg	Approx. 61 kg	Approx. 62 kg	Approx. 60 kg	Approx. 60 kg
Dimensions		See dimensional drawings.					
Accessory							
Operation manual		1 copy					
Input fuse (spare)	For 200 V	1 piece (30 A)					
	For 100 V	1 piece (50 A)	1 piece (50 A)	1 piece (60 A)	1 piece (50 A)	1 piece (50 A)	1 piece (50 A)
Power cord		1 piece, 3-core cabtyre cable for 200 VAC input (3.5 mm <sup>2</sup> , approx. 3 m)					
Voltage check chip		2 pieces					
Guard cap (with one hexagon wrench)		1 piece	2 pieces	2 pieces	2 pieces	2 pieces	2 pieces
Output terminal cover (with four mounting screws) *5		1 piece					

\*5: Mounted on the unit.

## Power consumption chart (TYPE III models)

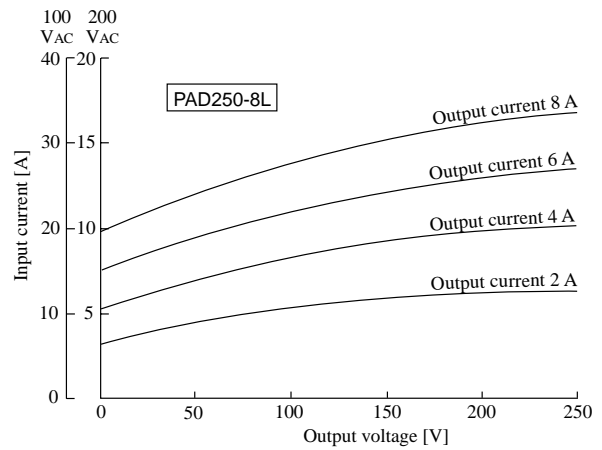
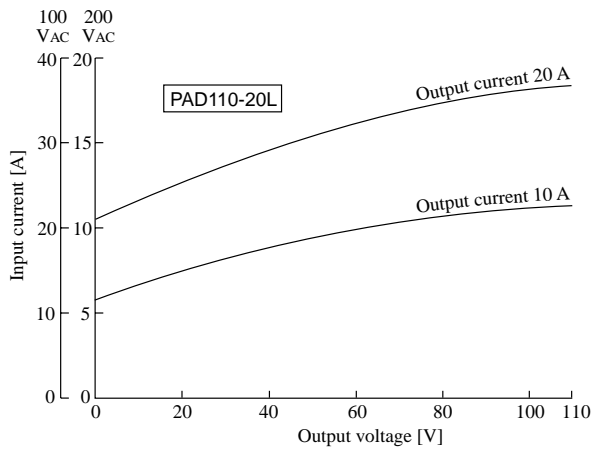
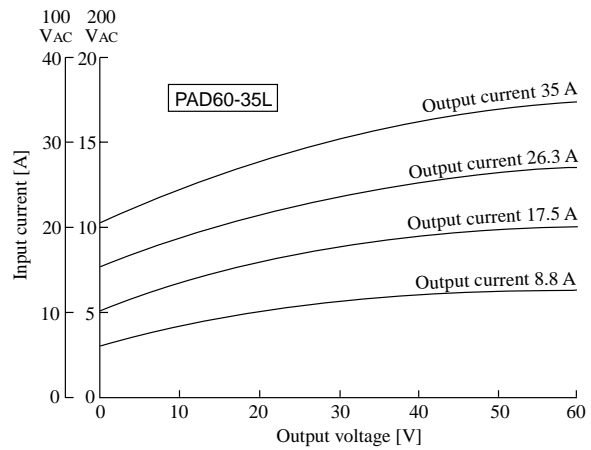
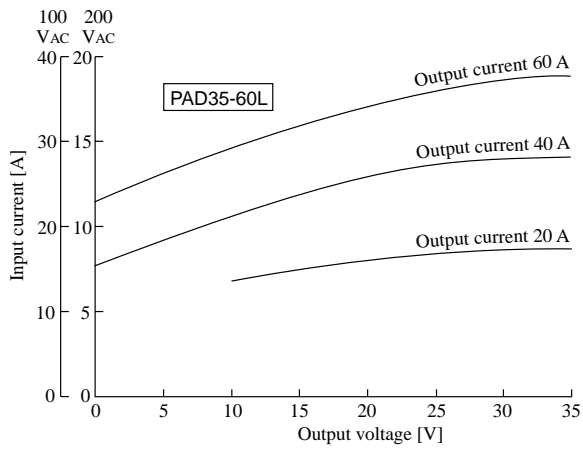
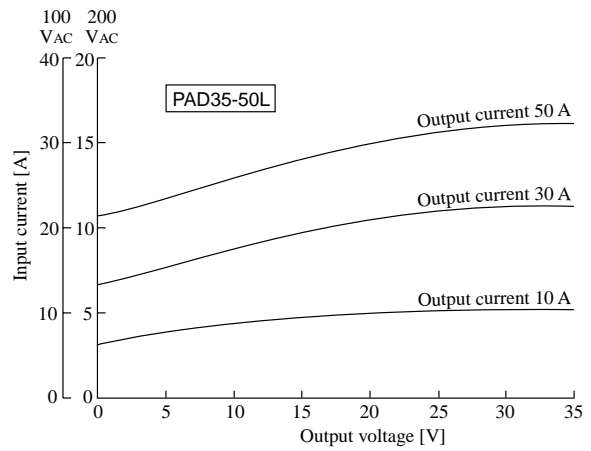
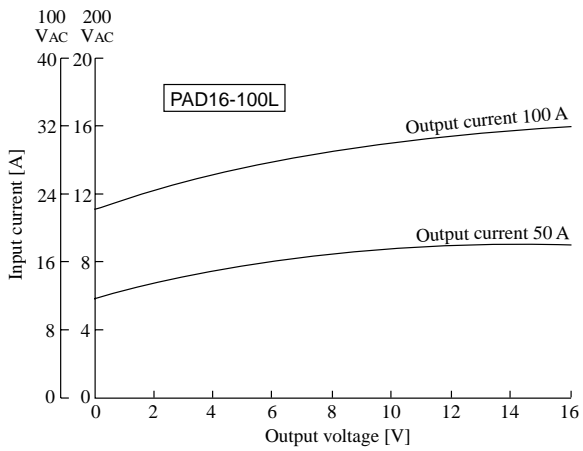



## Dimensional drawings (TYPE III models)

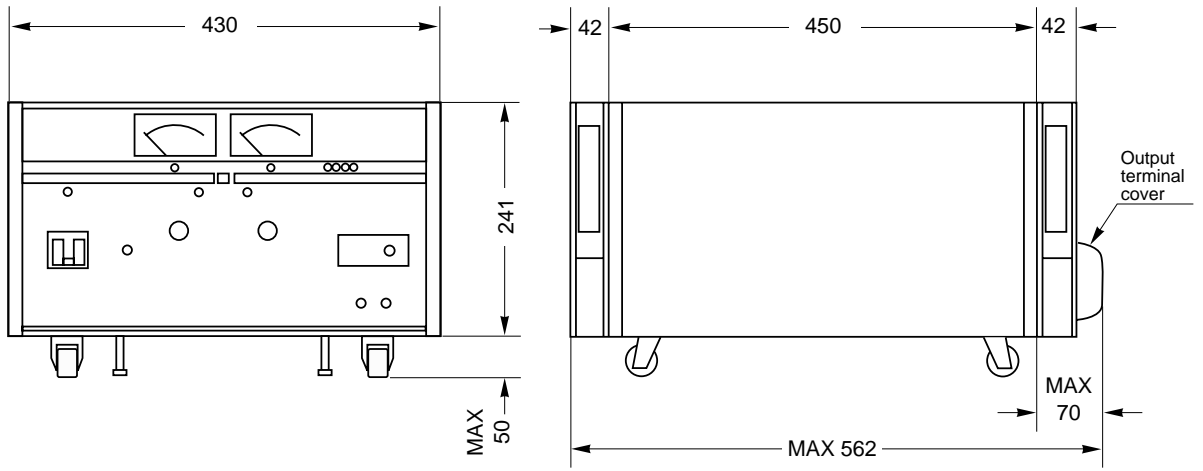

Unit: mm

## 7.2 TYPE IV models specifications

Unless otherwise specified, the specifications of the unit are based on the following conditions.

- The load is a pure resistance.
- The - (neg.) output terminal is connected to the GND terminal.
- The unit should be used after 30 minutes warming-up time.

Standard value and theoretical value do not guarantee performance. They should be referred to as target values only.

Type IV		PAD 35-100L	PAD 60-60L	PAD 110-30L	PAD 250-15L
Input					
Input voltage and frequency		200 VAC $\pm$ 10 %, 50/60 Hz, 1			
Power consumption, at 200VAC, rated load		Approx. 6.8 kVA	Approx. 6.8 kVA	Approx. 6.0 kVA	Approx. 6.0 kVA
Output					
Voltage	Rated voltage	35 V	60 V	110 V	250 V
	Variable range	0 to 35 V	0 to 60 V	0 to 110 V	0 to 250 V
	Resolution (theoretical value) *1	6 mV	11 mV	18 mV	45 mV
	Number of turns of panel control	10 turns			
Current	Rated current	100 A	60 A	30 A	15 A
	Variable range	0 to 100 A	0 to 60 A	0 to 30 A	0 to 15 A
	Resolution (theoretical value) *1	47 mA	30 mA	14.1 mA	7.5 mA
	Number of turns of panel control	1 turn, both of coarse and fine adjustment			
Constant voltage characteristics					
Ripple and noise (5Hz to 1MHz) RMS		0.5 mV	0.5 mV	1 mV	5 mV
Source effect (to $\pm$ 10% of AC input voltage) *2		0.005 %+1 mV	0.005 %+1 mV	0.005 %+1 mV	0.005 %+2 mV
Load effect (to 0 to 100% of output current) *2		0.005 %+2 mV	0.005 %+2 mV	0.005 %+2 mV	0.005 %+3 mV
Transient response (standard value) *2, *3		50 $\mu$ s			
Temperature coefficient (standard value)		50 ppm/			
Constant current characteristics					
Ripple and noise (5Hz to 1MHz) RMS		50 mA	20 mA	10 mA	5 mA
Source effect (to $\pm$ 10% of AC input voltage)		3 mA	3 mA	3 mA	1 mA
Load effect (to 0 to 100% of output voltage)		5 mA	5 mA	5 mA	3 mA
Constant voltage operation indication		C.V, green lamp indication			
Constant current operation indication		C.C, red lamp indication			

\*1: The value is calculated from the number of turns of the wire to wound potentiometer. In practice, use 3 to 5 times each value as a target.

\*2: Measured using the remote sensing function.

\*3: Time necessary for output voltage to return to  $\pm$  (0.05%+10mV) max. of rated value at 5 to 100% changes of output current.

Type IV		PAD 35-100L	PAD 60-60L	PAD 110-30L	PAD 250-15L
Range of operation temperature and humidity		0 to 40 / 10 to 90 %RH (no dew condensation allowed)			
Range of storage temperature and humidity		-10 to 60 / 0 to 70 %RH (no dew condensation allowed)			
Cooling system		Forced air cooling with fan			
Output polarity		Positive or negative grounding possible			
Isolation voltage		± 250 V	± 250 V	± 250 V	± 500 V
Insulation resistance					
Across chassis and input terminals		500VDC, 30M min.			
Across chassis and output terminals		500VDC, 20M min.			
Withstanding voltage					
Across input terminals and output terminals		Should withstand 1500 VAC, 1 min. with no abnormalities			
Across input terminals and chassis					
Meter display					
Voltmeter	Full scale, Class 2.5 (JIS)	35 V	60 V	110 V	250 V
Ammeter	Full scale, Class 2.5 (JIS)	110 A	60 A	32 A	15 A
Remote control					
Output voltage/control voltage ratio		35 V / approx. 10 V	60 V / approx. 10 V	110 V / approx. 10 V	250 V / approx. 10 V
Output voltage/control resistance ratio		35 V / approx. 10k	60 V / approx. 10k	110 V / approx. 10k	250 V / approx. 10k
Output current/control voltage ratio		100 A / approx. 0.55 V	60 A / approx. 0.45 V	30 A / approx. 0.45 V	15 A / approx. 0.75 V
Output current/control resistance ratio		100 A / approx. 550	60 A / approx. 550	30 A / approx. 550	15 A / approx. 550
Remote sensing		Possible (compensation one way approx. 1.2 V max.)			
Master-slave-control parallel operation		Possible			
Master-slave-control series operation		Possible			
Protective circuit					
Operation		POWER switch is turned off.			
Trip temperature of thermal protector		100			
Over voltage protection (OVP)	Voltage setting range (standard value)	6 to 38 V	7 to 66 V	20 to 130 V	50 to 280 V
	Trigger pulse width (standard value)	50 ms			
Input fuse rating		50 A			
Output fuse rating		100 A	60 A	30 A	15 A
Weight		Approx. 97 kg	Approx. 99 kg	Approx. 96 kg	Approx. 94 kg
Dimensions		See dimensional drawings.			
Accessory					
Operation manual		1 copy			
Input fuse (spare)		1 piece (50 A)			
Power cord		1 piece, 3-core cabtyre cable (8 mm <sup>2</sup> , approx. 4 m)			
Voltage check chip		2 pieces			
Guard cap (with one hexagon wrench)		1 piece			
Output terminal cover		1 piece (*4)			1 piece (*5)

\*4: Mounted on the unit. With four mounting screws

\*5: Mounted on the unit. With two mounting screws

## Power consumption chart (TYPE IV models)

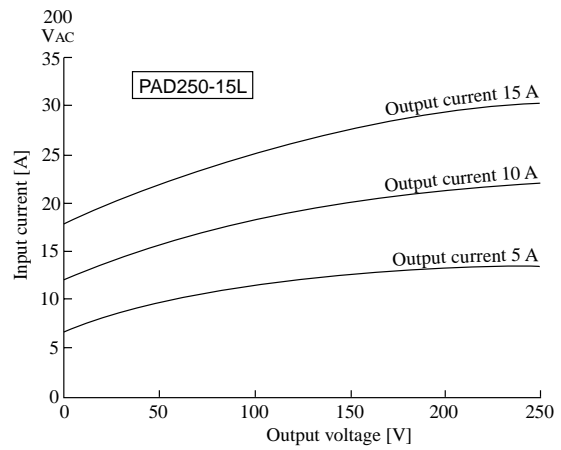
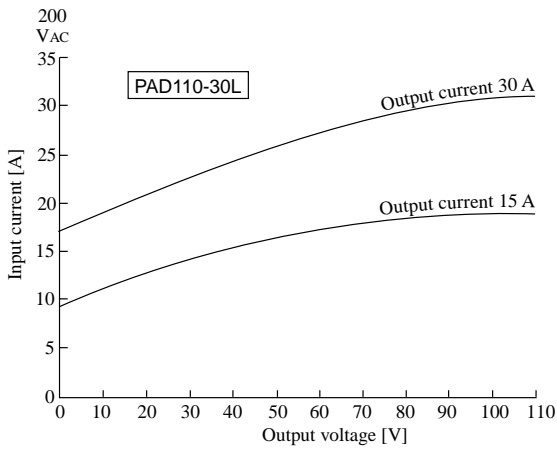
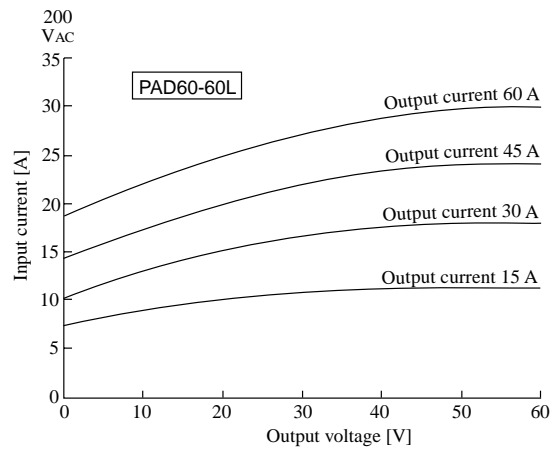
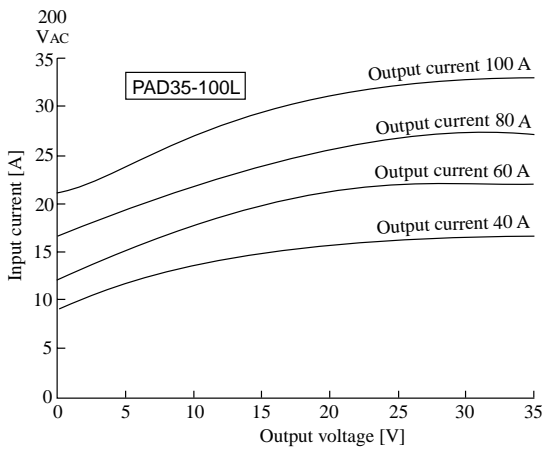

## Dimensional drawings (TYPE IV models)

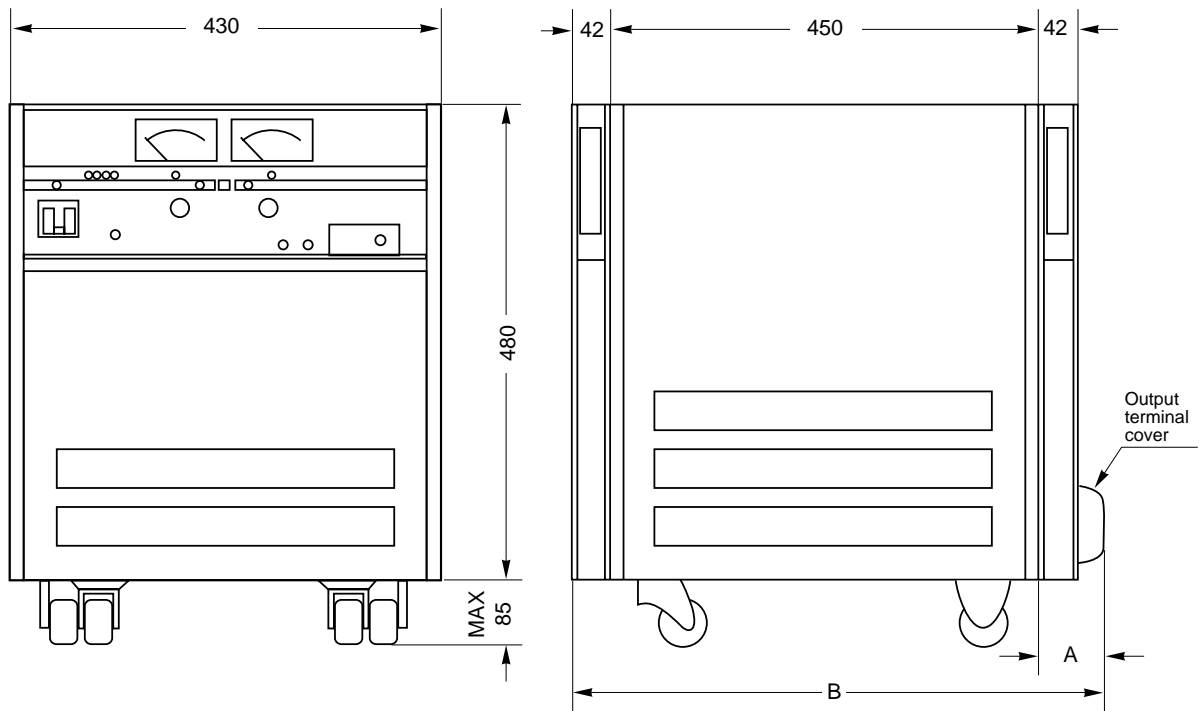

Type V	PAD 35-100L	PAD 60-60L	PAD 110-30L	PAD 250-15L
A		MAX 70		MAX 42
B		MAX 562		MAX 534

Unit: mm

## 7.3 TYPE V models specifications

Unless otherwise specified, the specifications of the unit are based on the following conditions.

- The load is a pure resistance.
- The - (neg.) output terminal is connected to the GND terminal.
- The unit should be used after 30 minutes warming-up time.

Standard value and theoretical value do not guarantee performance. They should be referred to as target values only.

Type V		PAD 35-200L	PAD 60-120L	PAD 110-60L
Input				
Input voltage and frequency		200 VAC $\pm$ 10 %, 50/60 Hz, 1		
Power consumption, at 200VAC, rated load		Approx. 13 kVA	Approx. 12 kVA	Approx. 11 kVA
Output				
Voltage	Rated voltage	35 V	60 V	110 V
	Variable range	0 to 35 V	0 to 60 V	0 to 110 V
	Resolution (theoretical value) *1	6.3 mV	11 mV	20 mV
	Number of turns of panel control	10 turns		
Current	Rated current	200 A	120A	60 A
	Variable range	0 to 200 A	0 to 120 A	0 to 60 A
	Resolution (theoretical value) *1	93 mA	56 mA	23 mA
	Number of turns of panel control	1 turn, both of coarse and fine adjustment		
Constant voltage characteristics				
Ripple and noise (5Hz to 1MHz) RMS		0.5 mV	0.5 mV	1 mV
Source effect (to $\pm$ 10% of AC input voltage) *2		0.005 %+1 mV		
Load effect (to 0 to 100% of output current) *2		0.005 %+2 mV		
Transient response (standard value) *2, *3		100 $\mu$ s		
Temperature coefficient (standard value)		50 ppm/		
Constant current characteristics				
Ripple and noise (5Hz to 1MHz) RMS		100 mA	50 mA	20 mA
Source effect (to $\pm$ 10% of AC input voltage)		30 mA	15 mA	10 mA
Load effect (to 0 to 100% of output voltage)		30 mA	15 mA	10 mA
Constant voltage operation indication		C.V, green lamp indication		
Constant current operation indication		C.C, red lamp indication		

\*1: The value is calculated from the number of turns of the wire to wound potentiometer. In practice, use 3 to 5 times each value as a target.

\*2: Measured using the remote sensing function.

\*3: Time necessary for output voltage to return to  $\pm$  (0.05%+10mV) max. of rated value at 5 to 100% changes of output current.

Type V		PAD 35-200L	PAD 60-120L	PAD 110-60L
Range of operation temperature and humidity		0 to 40 / 10 to 90 %RH (no dew condensation allowed)		
Range of storage temperature and humidity		-10 to 60 / 0 to 70 %RH (no dew condensation allowed)		
Cooling system		Forced air cooling with fan		
Output polarity		Positive or negative grounding possible		
Isolation voltage		± 250 V		
Insulation resistance				
Across chassis and input terminals		500VDC, 30M min.		
Across chassis and output terminals		500VDC, 20M min.		
Withstanding voltage				
Across input terminals and output terminals		Should withstand 1500 VAC, 1 min. with no abnormalities		
Across input terminals and chassis				
Meter display				
Voltmeter	Full scale, Class 1.5 (JIS)	40 V	66 V	120 V
Ammeter	Full scale, Class 1.5 (JIS)	200 A	120 A	60 A
Remote control				
Output voltage/control voltage ratio		35 V / approx. 10 V	60 V / approx. 10 V	110 V / approx. 10 V
Output voltage/control resistance ratio		35 V / approx. 10k	60 V / approx. 10k	110 V / approx. 10k
Output current/control voltage ratio		200 A / approx. 0.2 V	120 A / approx. 0.36 V	60 A / approx. 0.45 V
Output current/control resistance ratio		200 A / approx. 550	120 A / approx. 550	60 A / approx. 550
Remote sensing		Possible (compensation one way approx. 1.2 V max.)		
Master-slave-control parallel operation		Possible		
Master-slave-control series operation		Possible		
Protective circuit				
Operation		POWER switch is turned off.		
Trip temperature of thermal protector		100 at cooling package 130 at main power transformer		
Over voltage protection (OVP)	Voltage setting range (standard value)	3 to 38 V	4 to 66 V	5 to 129 V
	Trigger pulse width (standard value)	50 ms		
Input fuse rating		100 A		
Output fuse rating		200 A	120 A	60 A
Weight		Approx. 188 kg	Approx. 175 kg	Approx. 170 kg
Dimensions		See dimensional drawings.		
Accessory				
Operation manual		1 copy		
Power cord		1 piece, 3-core cabtyre cable (14 mm <sup>2</sup> , approx. 4 m)		
Voltage check chip		2 pieces		
Guard cap (with one hexagon wrench)		1 piece		
Output terminal cover		1 piece (*4)		1 piece (*5)

\*4: Mounted on the unit. With four mounting screws

\*5: Mounted on the unit. With two mounting screws

## Power consumption chart (TYPE V models)

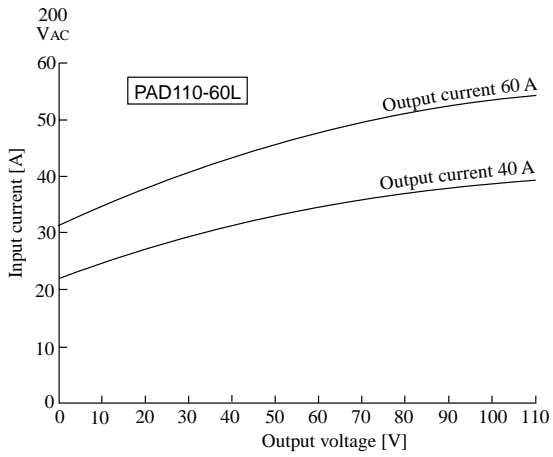
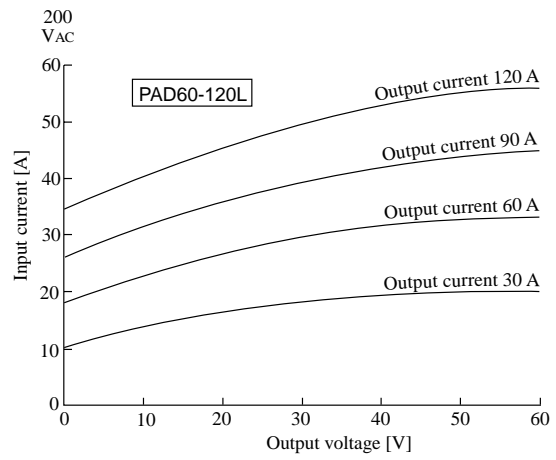
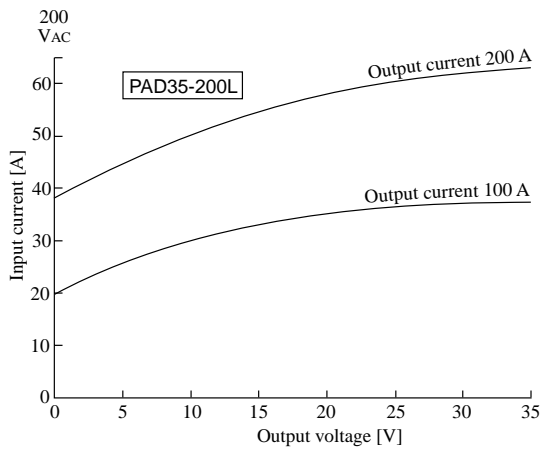



## Dimensional drawings (TYPE V models)

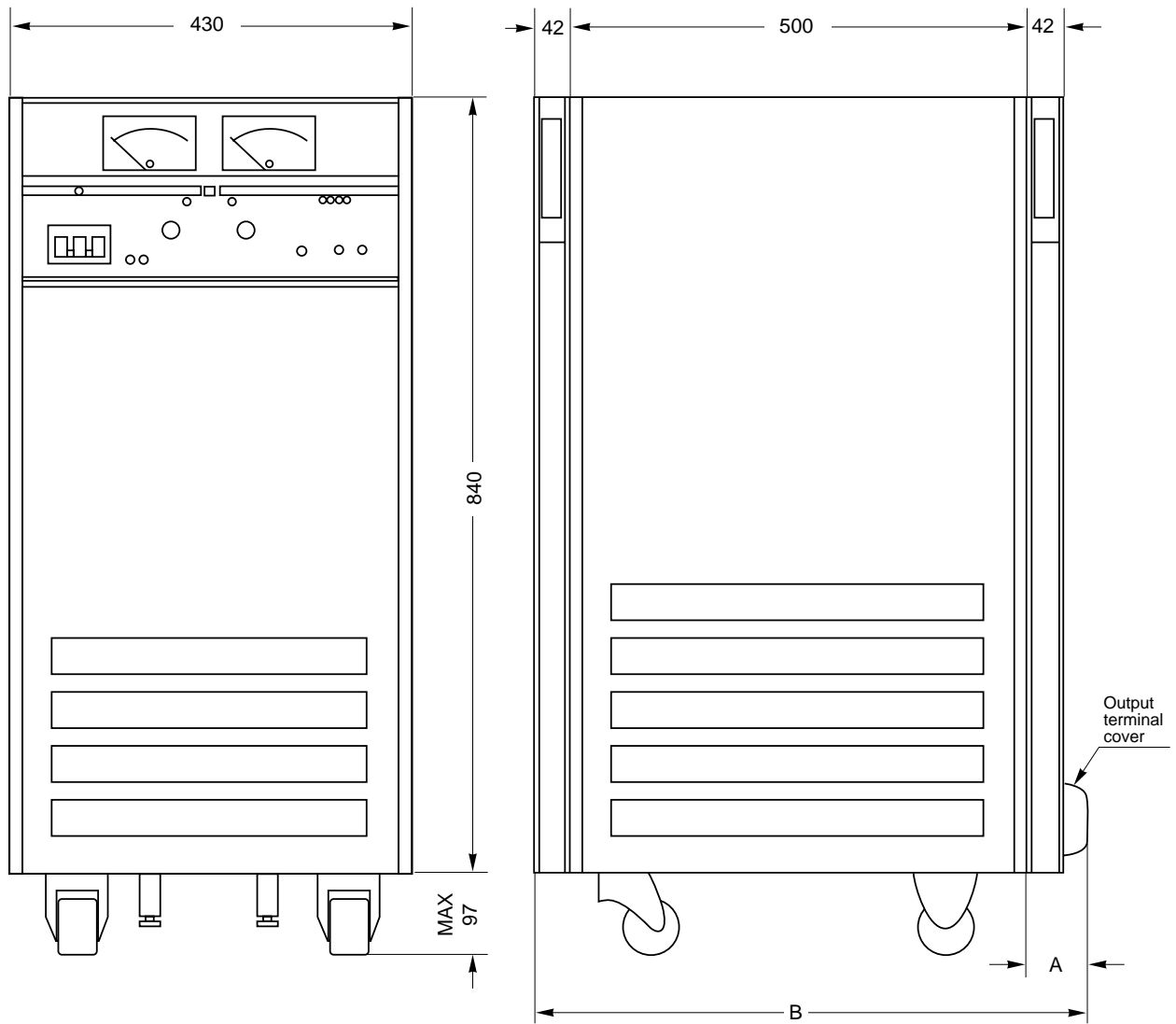

Type V	PAD 35-200L	PAD 60-120L	PAD 110-60L
A	MAX 70		MAX 42
B	MAX 612		MAX 584

Unit: mm



# Index

## Symbol

+S 5-10

-S 5-10

## A

A.FS variable resistor 5-5

AC input terminal board 5-11

AC power cord 1-10

Accessories 1-2

Adjustment 6-3

Ammeter 5-4

Ammeter zero-adjustment 5-4

at factory shipment 3-3

## C

C.C lamp 5-4

C.V lamp 5-5

caster 1-4

Changing the input power voltage 1-7

Chassis ground terminal 5-11

Cleaning 6-2

Connection to the output terminals 3-10

Constant current charge 4-32

constant current power supply 2-6, 3-7

constant voltage power supply 2-6, 3-6

Control terminal board 5-10

CURRENT setting knob 5-4

CURRENT/VOLT. LIMIT switch 5-4

## G

GND terminal 5-11

Grounding 1-12

Grounding the output terminal 2-9

guard cap 3-11

## I

I.OS variable resistor 5-5

incorporation into a rack P-2

Input offset voltage 4-10, 4-20

Inrush current 2-2

Inspection 6-2

Installation 1-3

Isolation voltage 2-9

## L

Load 2-3

load cables 3-8

## M

Malfunctions 6-17

Master-slave-control parallel operation 4-22

Master-slave-control series operation 4-26

moving 1-6

## N

Negative voltage 2-2

## O

O.V.P PRESET switch 5-5

O.V.P variable resistor 5-5

Output current control with external resistor 4-16

Output current control with external voltage 4-18

Output ON/OFF control 4-12, 4-14

Output terminals 5-10

Output voltage control

with external resistor 4-4, 4-6

Output voltage control with external voltage 4-9

OVP (OverVoltage Protection) 3-4

## P

parallel operation 4-22

POWER indication lamp 5-4

POWER switch 5-4

Protective circuits 2-8

## R

Remote sensing 4-2

Replacing the input fuse 6-14

## S

SAMPLING 5-10

Sensing terminals 5-10

series operation 4-26

Shutting off the POWER switch 4-30

stopper bolt 1-4

## **T**

Turning on the power 3-2

## **V**

V.FS variable resistor 5-5

V.OS variable resistor 5-5

VOLTAGE CHECK terminals 5-5

VOLTAGE setting knob 5-5

Voltmeter 5-4

Voltmeter zero-adjustment 5-4