

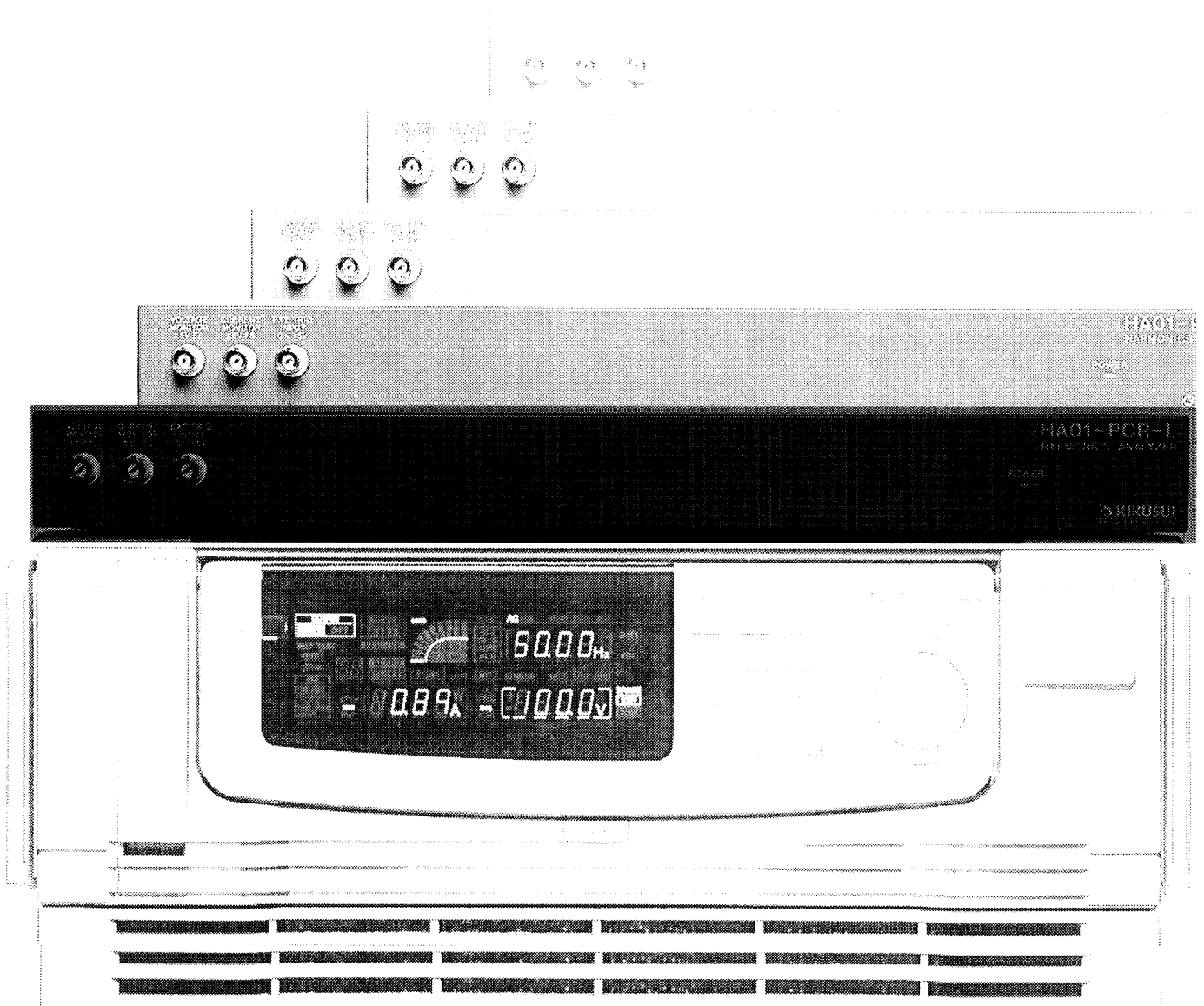

## HARMONICS ANALYZER

# *HA01F-PCR-L*

## OPERATION MANUAL



All or any parts of this manual may not be reproduced in any forms, without express written permission of Kikusui Electronics Corporation.

The contents of this manual, including the specifications of the instrument, are subject to change without notice.

©1995-2001 Copyright Kikusui Electronics Corporation.  
Printed in Japan. All rights reserved.

On Power Supply Source, it is requested to replace the related places in the operation manual with the following items.

(Please apply the item of ✓ mark.)

- Power Supply Voltage: to \_\_\_\_\_ V AC
- Line Fuse: to \_\_\_\_\_ A
- Power Cable: to 3-core cable (See Fig. 1 for the colors.)

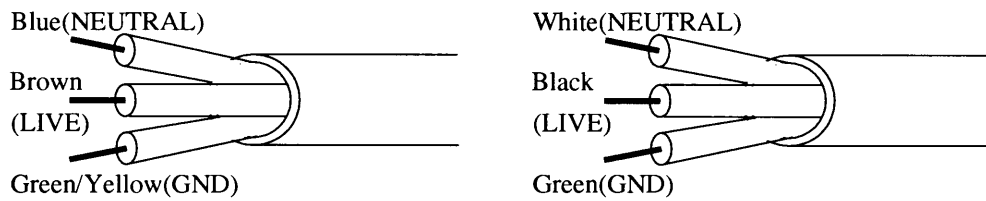

Fig. 1

Please be advised beforehand that the above matter may cause some alteration against explanation in the operation manual.

- \* AC Plug: In case of Line Voltage 125V AC or more, AC Plug is in principle taken off and delivered, in view of the safety.  
(AC Plug on 3-core cable is taken off in regardless of input voltages.)  
To connect the AC plug to the AC power cable, connect the respective pins of the AC plug to the respective core-wires (LIVE, NEUTRAL, and GND) of the AC power cable by referring to the color cables shown in Fig. 1.

Before using the instrument, it is requested to fix a suitable plug for the voltage used.

# ⚠ Safety Precautions

The following safety precautions must be observed to avoid fire hazard, electrical shock, accidents, and other failures. Keep them in mind and make sure that all of them are observed properly. Kikusui assumes no liability against any damages or problems resulting from negligence of the precautions.

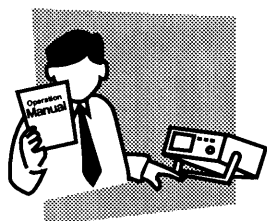

## Users

- This product must be used only by qualified personnel who understand the contents of this operation manual.
- If it is handled by disqualified personnel, personal injury may result. Be sure to handle it under supervision of qualified personnel (those who have electrical knowledge.)

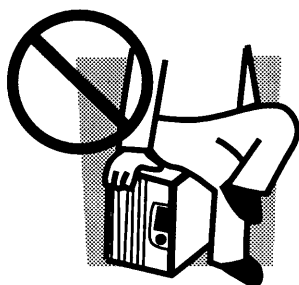

## Purposes of use

- If the product is to be used for purposes not described in this manual, contact your Kikusui agent in advance.

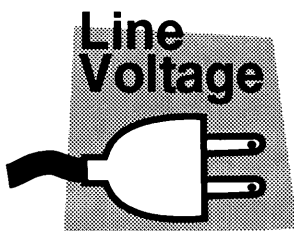

## Input power

- Use the product with the specified input power voltage.
- For applying power, use the AC power cable provided. The shape of the plug differs according to the power voltage and areas. Use the cable which is suitable for the line voltage used.

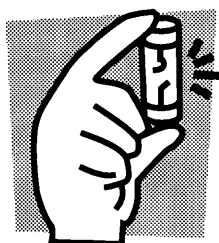

## Fuse

- With products with a fuse holder on the exterior surface, the fuse can be replaced with a new one. When replacing a fuse, use the one which has appropriate shape, ratings, and specifications.

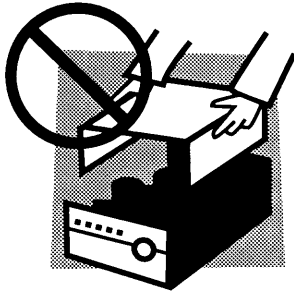

### Cover

- There are parts inside the product which may cause physical hazards. Do not remove the external cover. If the cover must be removed, contact your Kikusui agent in advance.

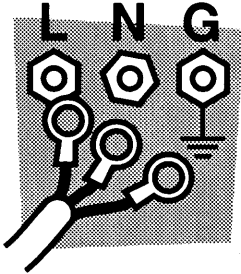

### Installation

- When installing products be sure to observe "Conditions at the Installation Location" described in this manual.
- To avoid electrical shock, connect the protective ground terminal to electrical ground (safety ground).
- When applying power to the products from a switchboard, be sure work is performed by a qualified and licensed electrician or is conducted under the direction of such a person.
- Be sure to use the AC power cable provided. Consult your Kikusui agent if other cable than included is to be used for some reason.
- When installing products with casters, be sure to lock the casters.



### Relocation

- Turn off the power switch and then disconnect all cables when relocating the product.
- Use two or more persons when relocating the product which weights more than 20 kg. The weight of the products can be found on the rear panel of the product and/or in this operation manual.
- Use extra precautions such as using more people when relocating into or out of present locations including inclines or steps. Also handle carefully when relocating tall products as they can fall over easily.
- Be sure the operation manual be included when the product is relocated.

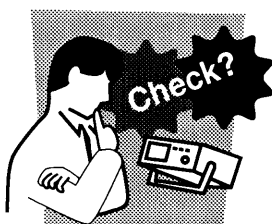

### Operations

- Check that the AC input voltage setting and the fuse rating are satisfied and that there is no abnormality on the surface of the AC power cable. Be sure to unplug the AC power cable or stop applying power before checking.
- If any abnormality or failure is detected in the products, stop using it

immediately. Unplug the AC power cable or disconnect the AC power cable from the switchboard. Be careful not to allow the product to be used before it is completely repaired.

- For output wiring or load cables, use connection cables with larger current capacity.
- Do not disassemble or modify the product. If it must be modified, contact your Kikusui agent.

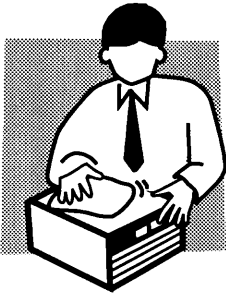

### **Maintenance and checking**

- To avoid electrical shock, be absolutely sure to unplug the AC power cable or stop applying power before performing maintenance or checking.
- Do not remove the cover when performing maintenance or checking. If the cover must be removed, contact your Kikusui agent in advance.
- To maintain performance and safe operation of the product, it is recommended that periodic maintenance, checking, cleaning, and calibration be performed.



### **Service**

- Internal service is to be done by Kikusui service engineers. If the product must be adjusted or repaired, contact your Kikusui agent.

# Safety Symbols

This operation manual and this product use the following safety symbols. Note the meaning of each of the symbols to ensure safe use of the product. (As using symbols depend on the product, all of symbols may not be used.)

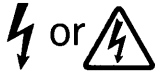

Indicates the presence of 1000V or higher. Never attempt to touch this part when the power switch of the product is turned on.



Indicates the possibility of personal injury or death. Never fail to follow the operating procedure. Do not proceed beyond a WARNING sign until the noted conditions are fully understood and met.



Indicates the existence of damage to the product or connected equipment. Always follow the operating procedure. Do not proceed beyond a CAUTION sign until the indicted conditions are fully understood and met.



Indicates additional information such as operating procedure.



Describes technical terms used in this manual.



Indicates action prohibited.



Indicates general warning, caution, risk of danger. When this mark is indicated on the product, refer the relevant section of the Operation Manual.



Indicates a grounding (earth) terminal.



Indicates a chassis grounding terminal.

# TABLE OF CONTENTS



Safety Precautions	II
Safety Symbols	V
INTRODUCTION	IX
General	IX
Features	IX
Chapter 1 SETUP	1-1
1.1 Check at Unpacking	1-2
1.2 Conditions at the Installation Location	1-4
1.3 Attaching Magnetic Sheets	1-5
1.4 Grounding	1-6
1.5 Connection to the PCR-L AC Power Supply	1-7
1.5.1 INPUT Terminal Board of the Current Sensor	1-7
1.5.2 Current-Sensor Cables	1-9
1.5.3 PCR-L Interface Card	1-10
(1) Installing the PCR-L Interface Card	1-10
1.6 Connection When Using the LIN40MA-PCR-L	1-11
1.7 Connecting the GPIB Cable	1-12
1.8 Connecting the Power Supply	1-13
1.9 Optional Bracket	1-14
Chapter 2 OPERATION METHOD	2-1
2.1 Checking Power-ON Operations	2-2
2.1.1 Independent Operation	2-2
2.1.2 Controlled Operation (Controlled by the PCR-L AC Power Supply)	2-3
2.1.3 Warm-up period	2-3
2.2 How to Use Output Terminals	2-4
2.2.1 OUTLET (Multi-outlet)	2-4
(1) Current-detection system	2-4



- 2.2.2 Setting the CURRENT-RANGE SELECTOR 2-5
- 2.2.3 OUTPUT Terminal Board 2-6
  - (1) Connecting the equipment under test 2-6
  - (2) Using the OUTPUT terminal board together with OUTLET (multi-outlet) 2-7
- 2.2.4 Maximum Measuring Current 2-7

## Chapter 3 PART NAMES AND FUNCTIONS \_\_\_\_\_ 3-1

- 3.1 Front Panel of the Harmonics Analyzer 3-2
- 3.2 Rear Panel of the Harmonics Analyzer 3-4
- 3.3 Current Sensor 3-7

## Chapter 4 MAINTENANCE AND CALIBRATION \_\_\_\_\_ 4-1

- 4.1 Cleaning 4-2
- 4.2 Inspection 4-2
- 4.3 Calibration 4-2

## Chapter 5 SPECIFICATIONS \_\_\_\_\_ 5-1

- 5.1 Current Measurement 5-2
- 5.2 Voltage Measurement 5-2
- 5.3 Harmonic Current Analysis 5-3
- 5.4 Voltage Fluctuation Analysis 5-4
- 5.5 Flicker Measurement 5-5
- 5.6 Power Measurement 5-5
- 5.7 Current-Distortion-Factor Measurement 5-6
- 5.8 Monitoring Output 5-6
- 5.9 External Trigger Input 5-6
- 5.10 General Specifications 5-7
  - Accessories list 5-8
- 5.11 Dimensional Diagrams 5-9
  - 5.11.1 Harmonics Analyzer 5-9
  - 5.11.2 Current Sensor 5-10

APPENDIX \_\_\_\_\_ A-1

Appendix 1 Loss in Power Measurement A-2

- (1) Example of calculating power loss A-2

Appendix 2 Relationship Between Peak Value and RMS Value for Voltage-and  
Current-Measurement Ranges A-4

- (1) Relationship between voltage-measurement ranges and peak values A-4
- (2) Relationship between current-measurement ranges and peak values A-5

INDEX \_\_\_\_\_ I-1

# INTRODUCTION

This Operation Manual describes the structure and electrical parts of the HA01F-PCR-L harmonics analyzer.

For details on how to operate the instrument, follow the instructions given in the operation manual for the dedicated software.

For instructions on how to handle hardware, including the PCR-L AC power supply, see the operation manual of the relevant equipment.

## General

---

The HA01F-PCR-L harmonics analyzer measures harmonic currents in a power line, including varying harmonic current. The instrument employs a time-domain measurement method using discrete Fourier transform (DFT) and is used in conjunction with a Kikusui PCR-L Series AC power supply.

Operations are achieved using dedicated software via an external personal computer. The HA01F-PCR-L harmonic analyzer is an advanced measuring instrument that measures voltage fluctuation and flicker evaluation using flicker meter function in addition to harmonic current measurements.

The instrument consists of a harmonics analyzer, current sensor, and PCR-L interface.

## Features

---

- Analysis of harmonic current including varying harmonic currents
- Continuous measurement for 2.5 minutes using a large-capacity memory
- High-speed data processing through a digital signal processor (DSP)
- High-precision voltage, current, and power measurements using 16-bit A/D converters that offer simultaneous voltage and current samplings
- Measurement of voltage fluctuations
- Meets International Electrotechnical Commission (IEC) standard and Guideline to reduce Harmonic emissions caused by electrical and electronic equipment for household and general use (JAPAN).

Harmonic current measurement : IEC61000-3-2

Ministry of Economy, Trade and Industry, Japan  
"Guideline to reduce Harmonic emissions caused by electrical and electronic equipment for household and general use" (JAPAN).

Voltage fluctuation measurement : IEC61000-3-3, IEC60868, IEC60868-0

- Can be used in conjunction with existing PCR-L AC power supplies

# 1

## Chapter 1 SETUP

This chapter describes the basic procedures for unpacking and installing the harmonics analyzer.

(Operations other than those of the instrument are expressed in *italics*.)

- 1.1 Check at Unpacking
- 1.2 Conditions at the Installation Location
- 1.3 Attaching Magnet Sheets
- 1.4 Grounding
- 1.5 Connection to the PCR-L AC Power Supply
- 1.6 Connection When Using LIN40M-PCR-L
- 1.7 Connecting the GPIB Cable
- 1.8 Connecting the Power Supply
- 1.9 Optional Bracket

# 1.1 Check at Unpacking

The instrument should be checked upon receipt for damage that might have occurred during transportation. Also check that all accessories have been provided.

Should the instrument be damaged or any accessory missing, notify your Kikusui agent.

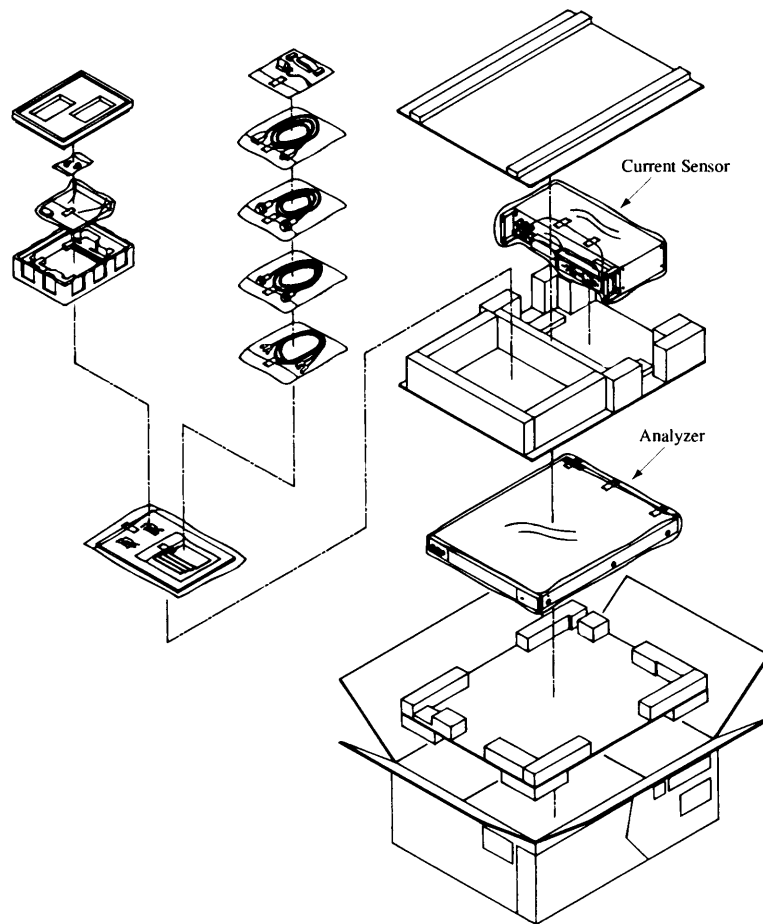

Fig. 1-1 Packing/Unpacking

## Caution

- When the product needs to be transported, always use the dedicated packing materials (those used for delivery).  
If additional packing materials are required, contact your Kikusui agent.
- Disconnect the input power cable and other cables for packing.

Accessories		Q'ty	Check
1	Current sensor cable (with 16 pins 3m for current)	1	
2	Current sensor cable (with 3 pins 3m for voltage)	1	
3	Current sensor cable (for terminal board, 60cm, with M6 crimped terminal)	3	
4	PCR-L interface card	1	
5	PCR-L interface card flat cable	1	
6	PCR-L interface card mounting screws (M3)	2	
7	Input power cable	1	
8	3-pin to 2-pin conversion adapter for the input power cable	1	
9	Magnet sheets	4	
10	Operation Manual	1	

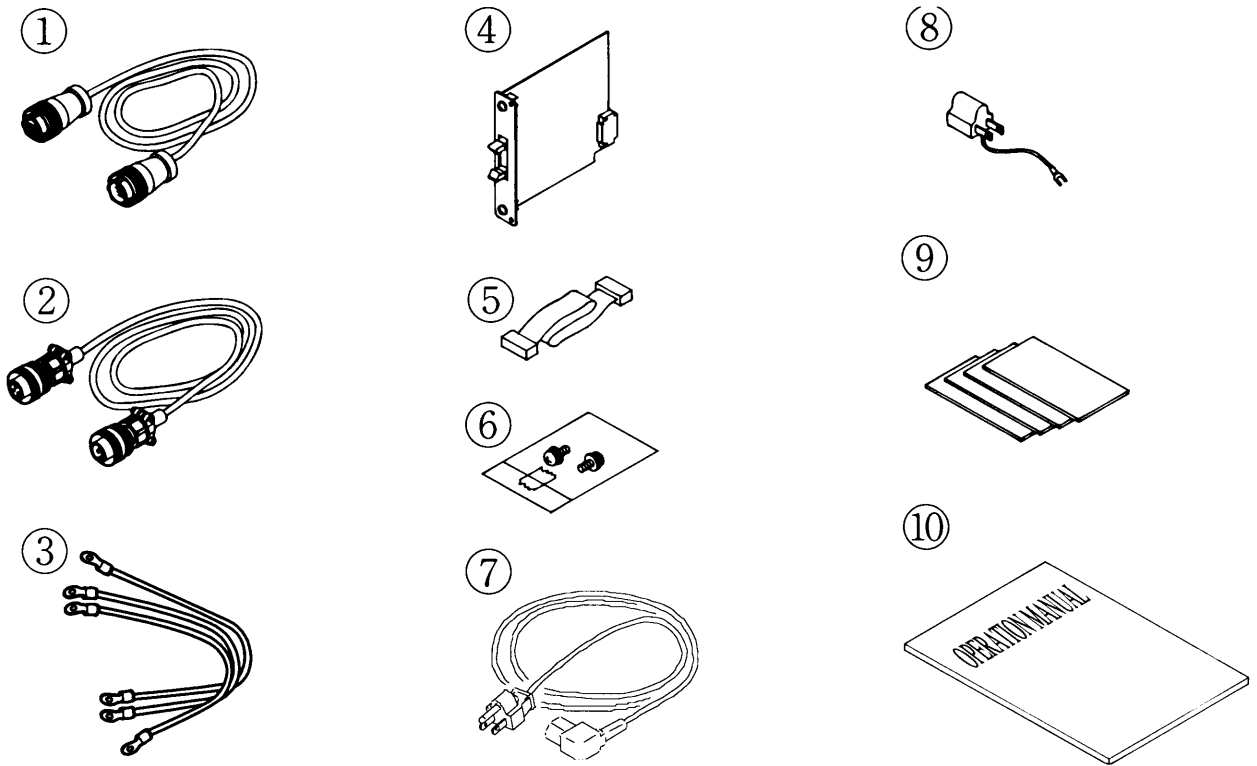

Fig. 1-2 Accessories

## 1.2 Conditions at the Installation Location

Be sure to observe the following precautions when installing the unit.

- Do not use the unit in a flammable atmosphere.

To prevent explosion or fire, do not use the unit near alcohol or thinner, or in an atmosphere containing such vapors.

- Avoid locations where the unit is exposed to high temperature or direct sunshine.

Do not locate the unit near a heater or in areas subject to drastic temperature changes.

Temperature range:  $23 \pm 5^{\circ}\text{C}$

- Avoid locations of high humidity.

Do not locate the unit in high-humidity locations, i.e., near a boiler, humidifier, water supply, etc.

Humidity range: 20% to 80% RH (without dew condensation)

- Do not place the unit in a corrosive atmosphere.

Do not install the unit in a corrosive atmosphere or one containing sulfuric acid mist, etc. This may cause corrosion of various conductors and imperfect contact with connectors, malfunction and failure, or in the worst case, a fire.

- Do not locate the unit in a dusty location.

- Do not use the unit where ventilation is poor.

Leave sufficient space around the tester to allow air to flow through its front and rear ports.

- Do not install the unit along a tilted section of floor or in a location subject to vibrations.

- Do not use the unit in locations affected by strong magnetic and/or electric fields.

## 1.3 Attaching Magnetic Sheets

- ① Turn the harmonics analyzer upside down and attach four magnetic sheets to the bottom of the harmonics analyzer unit.  
For the location of magnetic sheets, see Fig. 1-3.

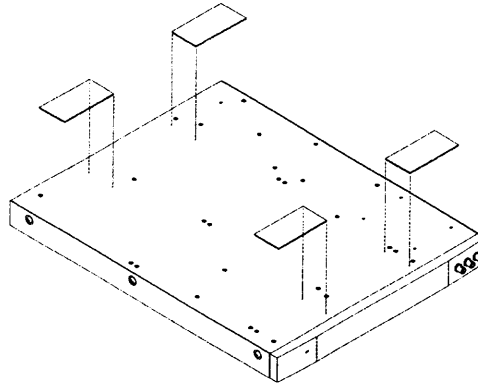

Fig. 1-3 Attaching Magnetic Sheets

- ② Turn the analyzer upright and place it on top of the PCR-L AC power supply.

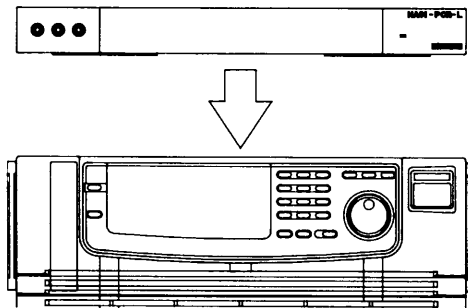

Fig. 1-4 Installing the Analyzer on an AC Power Supply

- ③ Check that the analyzer is firmly fixed by the magnetic sheets.

### Caution

- Do not place any article on the harmonics analyzer unit.

The top of the harmonics analyzer is not strong enough to support a heavy object and should also be free of any items for heat radiation. If another piece of equipment is above the harmonics analyzer unit, it should be kept at least 20 cm away. If such equipment generates heat, the harmonics analyzer unit should be kept at least 30 cm away.

- Handle with care to move the whole system by moving PCR-L AC power supply itself, because the harmonics analyzer is not physically mounted to PCR-L.



# 1.4 Grounding

Ground the instrument as follows:

- ① Connect terminal G of the INPUT terminal board of the current sensor to terminal G of the OUTPUT terminal board of the PCR-L AC power supply.

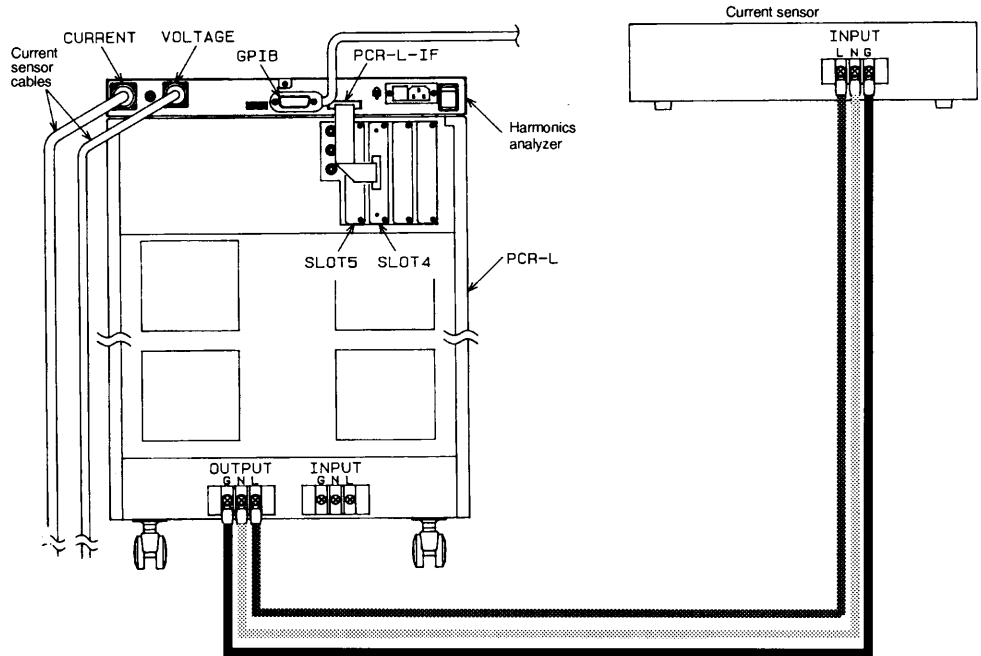

Fig. 1-5 Grounding

- ② Check that the  $\oplus$  terminal of the INPUT terminal board of the PCR-L AC power supply has been grounded.

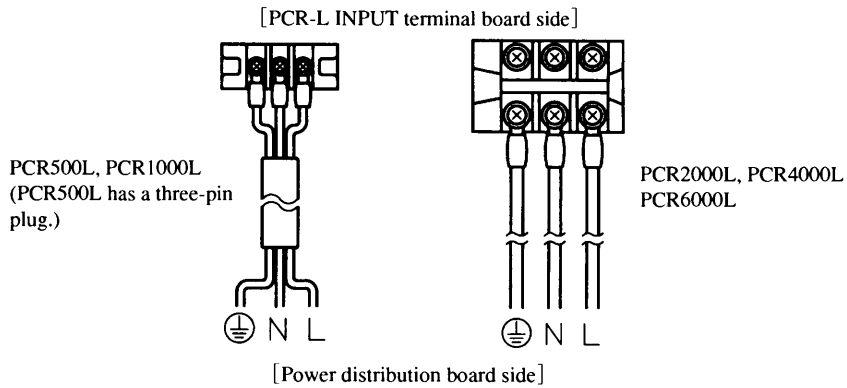

Fig. 1-6 Grounding Terminal of the PCR-L AC Power Supply

## 1.5 Connection to the PCR-L AC Power Supply

### Caution

- The HA01F-PCR-L harmonics analyzer is used in conjunction with a PCR-L AC power supply. However, the PCR-L AC power supplies with a built-in EMI filter cannot be used.
- Do not use the HA01F-PCR-L in conjunction with a commercial power-supply system.

### 1.5.1 INPUT Terminal Board of the Current Sensor

Follow the steps below while referring to Fig. 1-7, "Connection to the PCR-L AC Power Supply."

- ① Turn OFF the *POWER switch* of the PCR-L AC power supply and also cut off the power feed from the power distribution board.

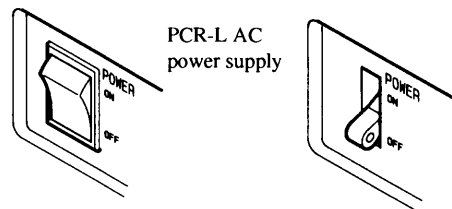

- ② Remove the transparent cover from the *INPUT terminal board* of the current sensor.
- ③ Connect the *INPUT terminal board* to the *OUTPUT terminal board* of the PCR-L AC power supply. Using the Current sensor cable for terminal board of the accessory, connect terminals L, N, and G to the appropriate terminals.

### Note

- For more information on connection to the PCR-L AC power supply, see Chapter 5, "Connecting a Load" of the PCR-L Series Operation Manual.

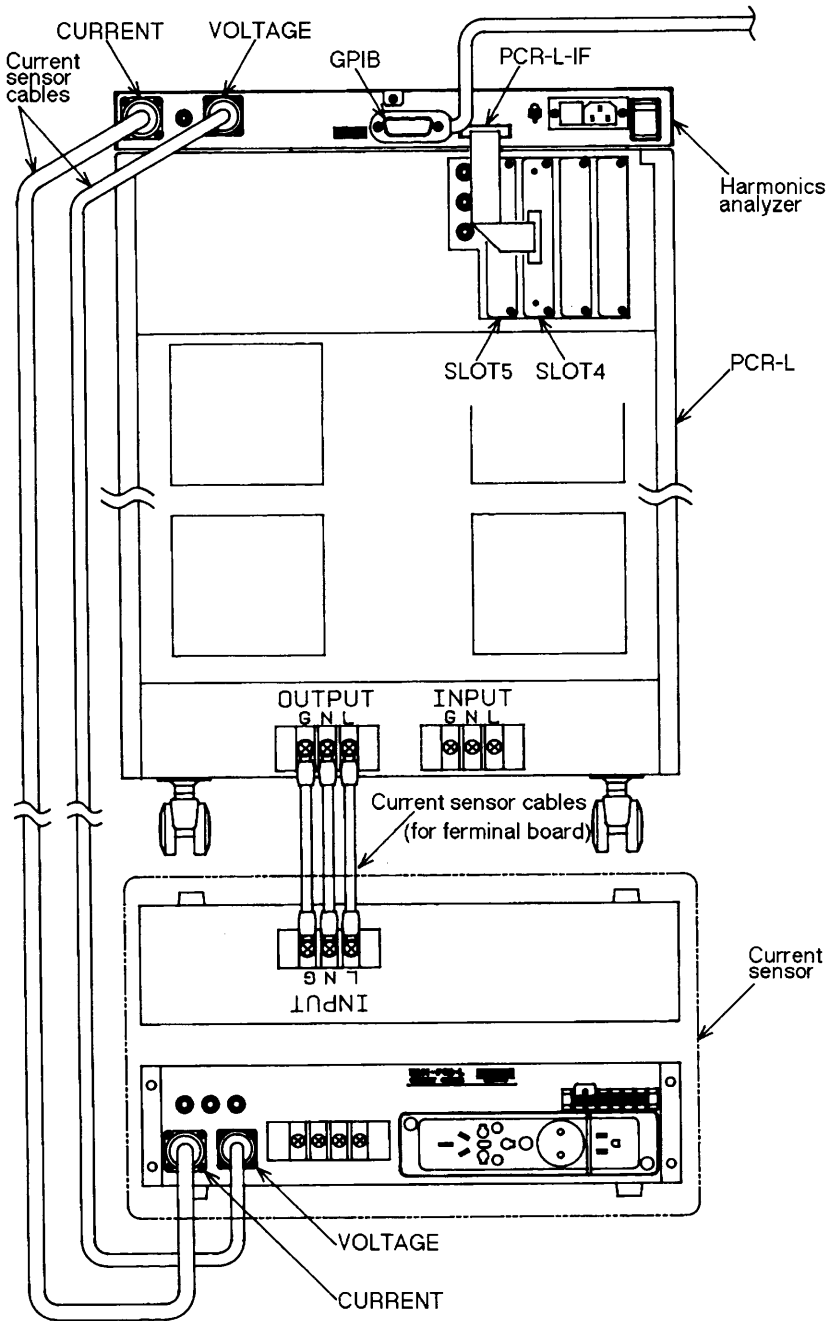

Fig. 1-7 Connection to the PCR-L AC Power Supply

- ④ Replace the cover removed in step ②.

**WARNING**

- Never fail to install the cover on the INPUT terminal, to avoid electric shock hazards as high voltage will be applied to the terminal.

## 1.5.2 Current-Sensor Cables

Two current sensor cables are provided: one with 16 pins for current signals and the other with 3 pins for voltage signals. The current sensor cables have a pin connector with a metal cover at one end and a socket connector with a metal cover at the other end.

The pin connector is connected to the current sensor; the socket connector is connected to the harmonics analyzer side.

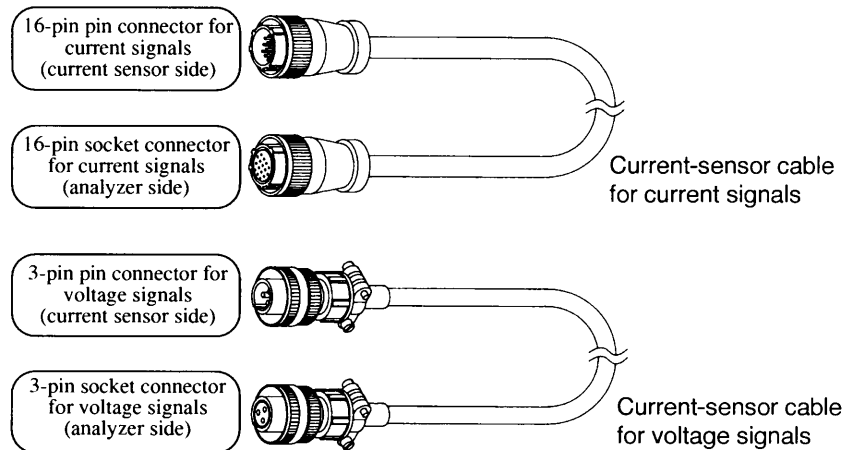

Fig. 1-8 Current-Sensor Cables

Connect the current-sensor cables between the current sensor and harmonics analyzer as shown in Fig. 1-7 and turn a locking ring to firmly connect the cables.

### Caution

- The current sensor must be installed at least 20 cm away from other equipment to avoid electromagnetic interference.
- When the harmonics analyzer needs to be moved, always disconnect the current-sensor cables (both 16-pin current use and 3-pin voltage use) from the analyzer. Otherwise, stress will be applied to the connectors.
- Before disconnecting a current-sensor cable (either for 16-pin current use or 3-pin voltage use), always turn OFF the POWER switch of the harmonics analyzer.

## 1.5.3 PCR-L Interface Card

A PCR-L interface card must be installed in *slot 4 or 5* of the PCR-L AC power supply.

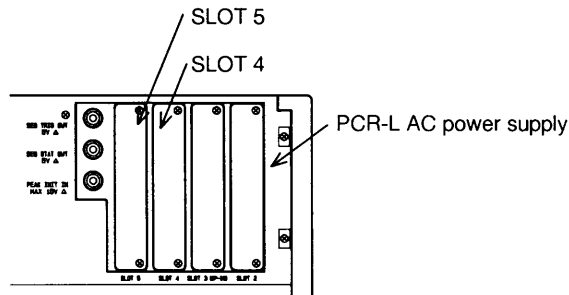

### (1) Installing the PCR-L Interface Card

Before installing the interface card (hereafter referred to as "Card"), always turn OFF the *POWER switch* of the PCR-L AC power supply.

- ① Remove the *slot cover*.

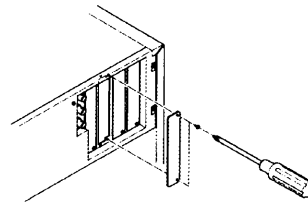

- ② Hold the panel part of the Card.
- ③ Hold the Card so that the parts-mounted side of the Card PCB is to the right, and lower the PCB part onto the grooves of the slot.
- ④ Carefully insert the Card into the far end of the slot, making sure that the Card stays in the grooves.
- ⑤ After inserting the Card to the far end of the slot, fix it to the PCR-L AC power supply with the provided screws. This completes installation of the Card.
- ⑥ Connect the flat cable provided for the instrument between the Card's connector and the PCR-L-IF connector in the harmonics analyzer unit.

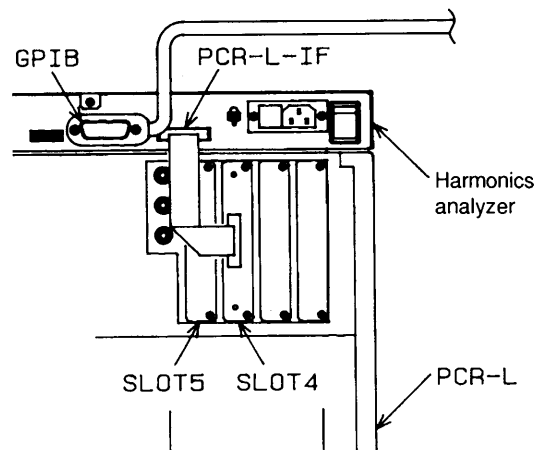

# 1.6 Connection When Using the LIN40MA-PCR-L

## Note

- The LIN40MA-PCR-L can be used in the same manner. In this case, replace LIN40MA with LIN40M in this manual.

Follow the procedure below while referring to Fig. 1-9.

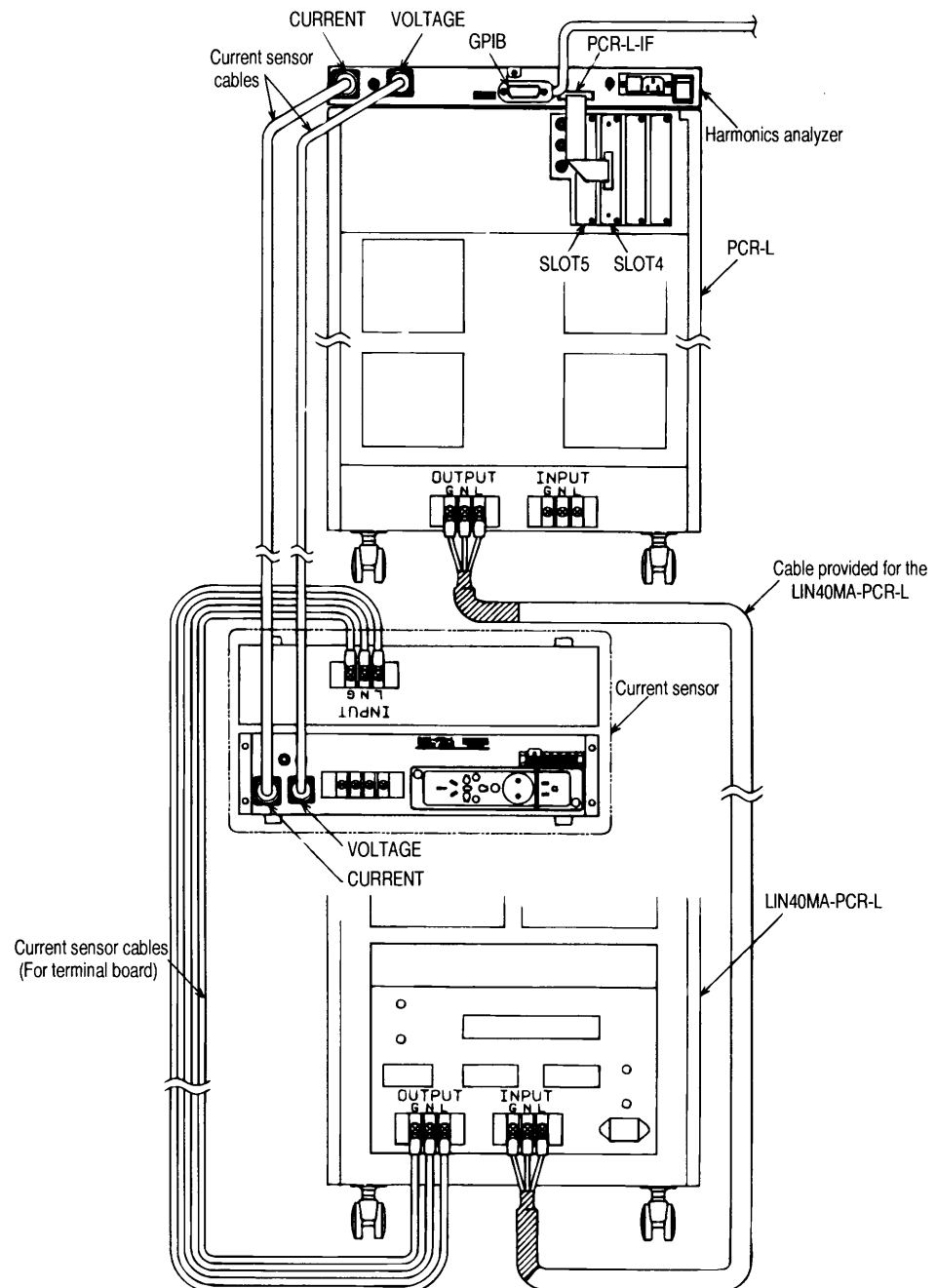

Fig. 1-9 Connection When Using the LIN40M-PCR-L

- 
- ① Turn OFF the *POWER switch* of the PCR-L AC power supply and also cut off the power feed from the power distribution board.
  - ② Remove the transparent cover from the *INPUT terminal board* of the current sensor.
  - ③ Connect the *INPUT* terminal board of the current sensor unit to use the current sensor cable of accessory to the *OUTPUT* terminal board of the LIN40MA-PCR-L.

————— Caution —————

- Always use the cable provided for the LIN40MA-PCR-L for connection between the *INPUT* terminals of the LIN40MA-PCR-L and the *OUTPUT* terminals of the PCR-L AC power supply.

## 1.7 Connecting the GPIB Cable

————— Caution —————

- Before connecting the GPIB cable, always turn OFF the *POWER* switches of the HA01F-PCR-L harmonics analyzer and personal computer (PC) used to control the instrument.

Align the plug configuration of the GPIB cable with the connector configuration of the instrument, then connect the cable.

For requirements of the PC to be used for instrument control, refer to the instructions given in the operation manual for the software dedicated to the HA01F-PCR-L.

————— Note —————

- No GPIB cable is provided for the HA01F-PCR-L.

# 1.8 Connecting the Power Supply

- ① Check that no input power cable is connected to the AC INPUT of the harmonics analyzer.
- ② Switch the voltage selector that also acts as a fuse holder to the appropriate setting.
- ③ Connect the input power cable to the AC INPUT. Always use the input power cable provided for the HA01F-PCR-L.

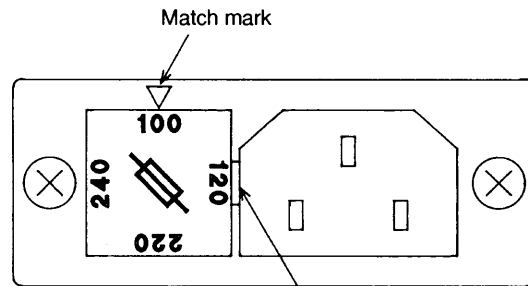

Insert the tip of a screwdriver here to remove the cover.  
Set the indication corresponding to the input voltage range to the match mark, then replace the cover.

Fig. 1-10 Fuse Holder

## Voltage Indications and Input Voltage Range

Indication	Input voltage range	Indication	Input voltage range
100	85 - 110V	220	198 - 242V
120	108 - 132V	240	207 - 250V

Table 1-3 Voltage Indications and Input Voltage Range

### Fuses

Use 250 V, 1 A normal-type fuses (6.3 diameter × 32 mm).

### Power plug

At shipment, the power cable has a plug configuration for use in North America.

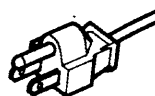

A power plug with different plug configurations for other areas should be obtained by the customer.



## 1.9 Optional Bracket

The following optional brackets ( special order ) are available to fix the current sensor on the PCR-L AC Power Supply.

MODEL	adapt to PCR-L AC Power Supply
KJB01 HA01-PCR-L	PCR1000L , PCR2000L
KJB02 HA01-PCR-L	PCR4000L , PCR6000L

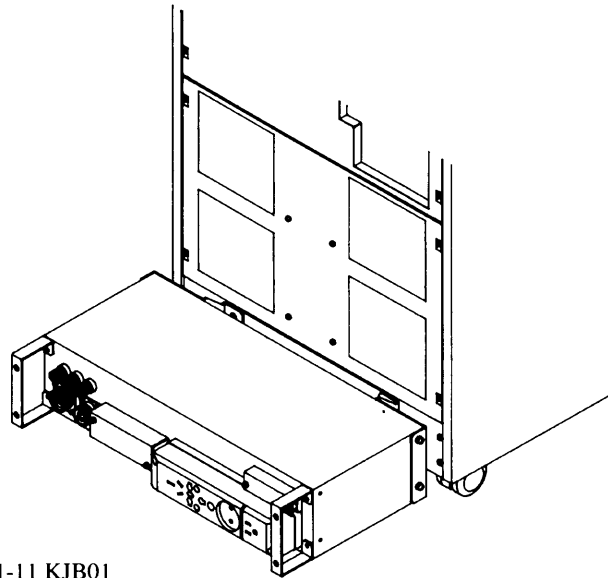

Fig. 1-11 KJB01

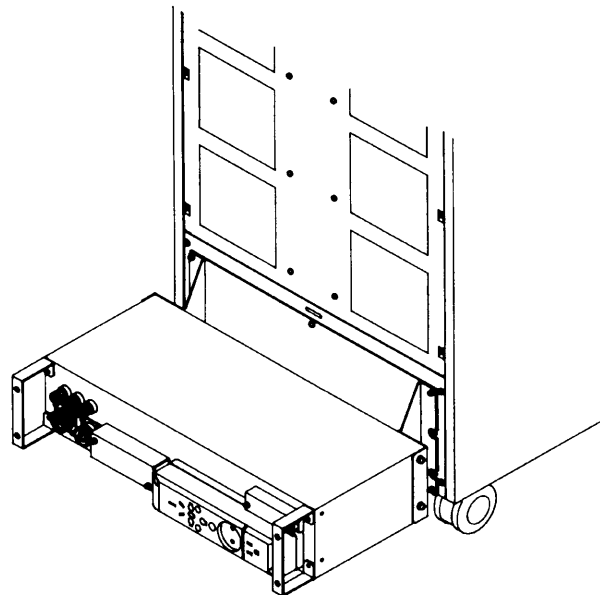

Fig. 1-12 KJB02

# 2

## Chapter 2

# OPERATION METHOD

This chapter describes operations from power-ON to actual operations.  
(Operations other than those of the instrument are expressed in *italics*.)

2.1 Checking Power-ON Operation

2.2 How to Use Output Terminals

## 2.1 Checking Power-ON Operations

The HA01F-PCR-L harmonics analyzer can be turned ON by either independent operation or controlled operation (controlled by a PCR-L AC power supply).

### Caution

- To check power-ON operations, the OUTPUT terminal board and OUTLET of the current sensor should be free of cables.
- Check that the current-sensor cables (one with 16 pins for current signals and the other with 3 pins for voltage signals) are connected between the harmonics analyzer and current sensor.

### 2.1.1 Independent Operation

- ① Check that the POWER switch at the rear of the harmonic analyzer unit is OFF.

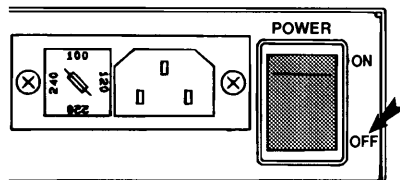

- ② Check that no cables are connected to the OUTPUT terminal board and OUTLET of the current sensor.

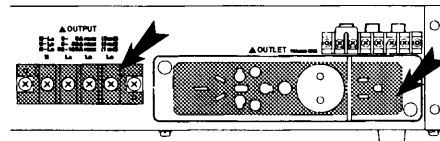

- ③ Check that the current-sensor cables (one with 16 pins for current signals and the other with 3 pins for voltage signals) are connected between the harmonics analyzer and current sensor.
- ④ Set the S1 switch at the rear of the analyzer to INDEPENDENT.
- ⑤ Turn ON the POWER switch at the rear of the analyzer. The green POWER LED on the front panel of the analyzer lights up.

This completes checking of the independent power-ON operation.

## 2.1.2 Controlled Operation (Controlled by the PCR-L AC Power Supply)

Checking controlled power-ON operation requires operations of the PCR-L AC power supply. Therefore, you should also refer to the operation manual for the AC power supply.

- ① Check that the **POWER** switch at the rear of the harmonics analyzer is OFF.
- ② Check that the *POWER switch* of the PCR-L AC power supply is also OFF.

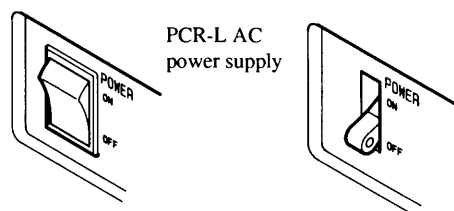

- ③ Check that no cables are connected to the **OUTPUT** terminal board and **OUTLET** of the current sensor.
- ④ Check that the current sensor cables (one with 16 pins for current signals and the other with 3 pins for voltage signals) are connected between the harmonics analyzer and current sensor.
- ⑤ Set the **S1** switch at the rear of the analyzer to **CONTROLLED**.
- ⑥ Turn **ON** the **POWER** switch at the rear of the harmonics analyzer.
- ⑦ Turn **ON** the *POWER switch* of the PCR-L AC power supply. This allows power to be fed to the instrument, lighting the green **POWER LED** on the front panel of the analyzer.
- ⑧ Turn **OFF** the *POWER switch* of the PCR-L AC power supply.

This completes checking of controlled power-ON operation.

### Note

- For controlled operation, leave the **POWER** switch of the instrument **ON**. The instrument's power is automatically turned **ON/OFF** by turning **ON/OFF** the *POWER switch* of the PCR-L AC power supply.
- If the **POWER** switch of the instrument cannot be normally turned **ON/OFF** by controlled operation, check the following.
  - ① A PCR-L interface card must be installed in *SLOT 4 or 5* of the PCR-L AC power supply.
  - ② The PCR-L interface card connector must be connected to the PCR-L-IF connector of the instrument using the flat cable provided for the instrument.

## 2.1.3 Warm-up period

The instrument requires a warm-up period of more than 30 minutes before starting measurement operations.

# 2.2 How to Use Output Terminals

## 2.2.1 OUTLET (Multi-outlet)

This outlet is available when the input power cable of equipment whose harmonic current is to be measured has a power plug. The OUTLET is compatible with most of the power plugs used worldwide.

Countries	Standards	Plug configuration	Rating	
Japan USA Canda	JIS UL CSA		2P 15A 125V	✓
			Two pins and a ground 15A 125V	✓
Australia	AS		2P 15A 250V	✓
			2P 7.5A 250V	✓
			Two pins and a ground 10A 250V	✓
			Two pins and a ground 15A 250V	✓
Swiss	SEV		2P 10A 250V	✓
			Two pins and a ground 10A 250V	✓
Italy	CEI		Two pins and a ground 10A 250V	✓

Countries	Standards	Plug configuration	Rating	
Europe	CEE DIN		2P 2.5A 250V	✓
			2P 10/16A 250V	✓
			Two pins and a ground 10/16A 250V Side-part earth	✓
			Two pins and a ground 10/16A 250V Double earth	✓
			Two pins and a ground 10/16A 250V Pin earth	
			2P 5A 250V	✓
United Kingdom	BS		Two pins and a ground 5A 250V	✓
			Two pins and a ground 15A 250V	✓
			Two pins and a ground 13A 250V	✓

Excerpt from a catalog of Matsushita Electric Works

### (1) Current-detection system

Figure 2-1 shows the principle diagram of current detection in the current sensor.

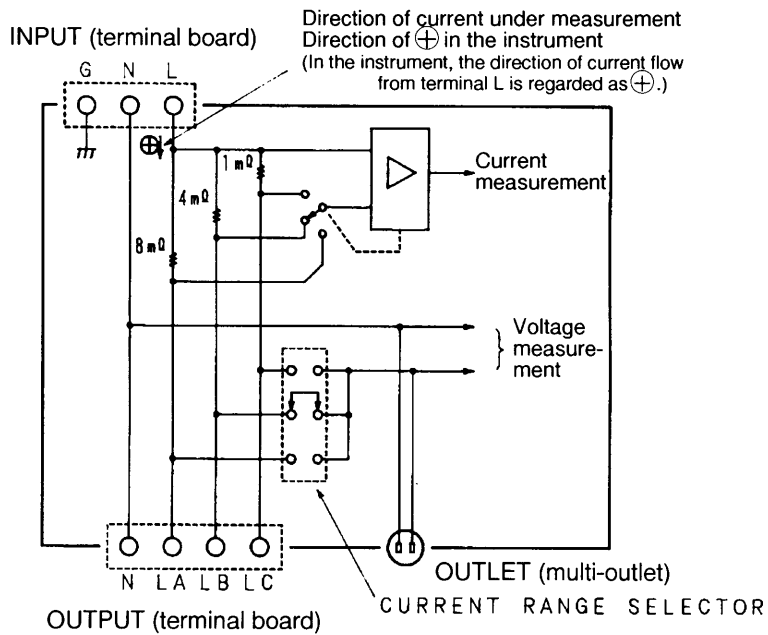

Fig. 2-1 Principle of Current Detection

## 2.2.2 Setting the CURRENT-RANGE SELECTOR

- ① Check that the *POWER switch* of the PCR-L AC power supply is OFF.

### WARNING

- High voltage is applied to the terminals. Always turn OFF the *POWER switch* of the PCR-L AC power supply before setting the CURRENT-RANGE SELECTOR.

- ② Connect the power plug of equipment under test to the corresponding part of the OUTLET.
- ③ Remove the transparent cover from the CURRENT-RANGE SELECTOR.
- ④ Install the short bar of the CURRENT-RANGE SELECTOR in the position corresponding to the input current of the equipment under test. (See Description below.)
- ⑤ Replace the cover removed in step ③.

### WARNING

- High voltage is present at the terminals; always use the instrument with the transparent cover in place.

This completes the setting of the CURRENT-RANGE SELECTOR.

### Description

Further instructions on setting the CURRENT-RANGE SELECTOR in relation to the power consumption of the equipment under test

⊙For capacitor-input-type rectifying circuits

With a power factor of 0.6 and a current waveform crest factor of 3:

Position of the Short Bar and Power Consumption of Equipment Under Test

Short bar	100 V supply voltage	230 V supply voltage
0 - 8A peak (8mΩ)	0 - 160W	0 - 368W
8A - 32A peak (4mΩ)	160W - 640W	368W - 1.47kW
32A - 45A peak (1mΩ)	640W - 900W	1.47kW - 2.07kW

\* Values in the table above are obtained by converting currents by RMS values. All rated currents are specified using peak values.

- As shown in Fig. 2-1, Principle of Current Detection, the CURRENT-RANGE SELECTOR is used to select the current-detecting resistor. It also switches the input of the terminal voltage measurement of the equipment under test.
- Since the measurement of the equipment's power is also important in the harmonic current measurement of the equipment's power line, the measurement of current and voltage is essential.

### Caution

- The maximum load current of the OUTLET (multi-outlet) is 15 A RMS.

## 2.2.3 OUTPUT Terminal Board

### (1) Connecting the equipment under test

Use the terminal corresponding to load current.

- ① Check that the *POWER switch* of the PCR-L AC power supply is OFF.

#### WARNING

· High voltage is applied to the terminals. Always turn OFF the *POWER switch* of a PCR-L AC power supply before connecting the equipment under test.

- ② Remove the transparent cover from the OUTPUT terminal board.
- ③ Connect the input power cable of the equipment under test to the N-LA, N-LB, or N-LC terminal. (See Description below.)

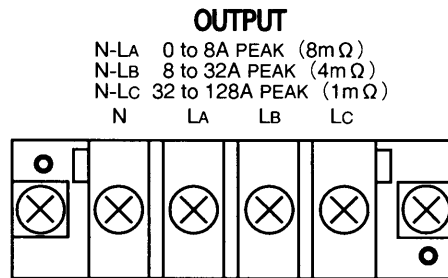

Fig. 2-2 OUTPUT Terminal Board

#### Description

Further instructions on selecting the terminal in relation to the power consumption of the equipment under test

- ◎ For capacitor-input-type rectifying circuits

With a power factor of 0.6 and a current waveform crest factor of 3:

Terminal to be Connected and Power Consumption of Equipment Under Test

Terminal to be connected	100 V supply voltage	230 V supply voltage
N to L A (0~8A peak)	0 to 160W	0 to 368W
N to L B (8~32A peak)	160W to 640W	368W to 1.47kW
N to L C (32A~128A peak)	640W to 2.4kW	1.47kW to 5.52kW

\* Values in the table above are obtained by converting currents by RMS values. All rated currents are specified using peak values.

- ④ Replace the cover removed in step ②.

**WARNING**

- High voltage is applied to the terminals; always use the instrument with the transparent cover in place.

- ⑤ Set the CURRENT-RANGE SELECTOR according to the table below.

Terminal to Which Equipment Under Test is Connected and Position of the CURRENT-RANGE SELECTOR'S Short Bar

Terminal to which equipment under test is connected	Position of short bar
N-LA	0 to 8A PEAK
N-LB	8 to 32A PEAK
N-LC	32 to 45A PEAK

**Caution**

- Over current flow may burn the current detecting resistor; the OUTPUT terminal board should be used at less than the peak current specified for each terminal. The terminal board is designed to withstand current twice the peak current of each terminal; however, allow the terminal board to cool for more than 30 minutes if current greater than the rated current flows.

(2) Using the OUTPUT terminal board together with OUTLET (multi-outlet)

Both the OUTPUT terminal board and OUTLET (multi-outlet) can simultaneously bear loads. However, make sure that the total value of current at the OUTPUT and OUTLET is within the set current range of the OUTPUT terminal board.

## 2.2.4 Maximum Measuring Current

Current detecting resistor	Current range	Maximum RMS to be measured	
		For a crest factor of 1.41	For a crest factor of 3
8mΩ	8A PEAK	5.65A RMS	2.66A RMS
4mΩ	32A PEAK	22.6 A RMS	10.66A RMS
1mΩ	128A PEAK	40.0 A RMS	40.0 A RMS

For more information on measurement ranges, see Appendix, "Relationship Between Peak Value and RMS Value for Voltage-and Current-Measurement Ranges."



# 3

---

## Chapter 3

# PART NAMES AND FUNCTIONS

This chapter denotes the names of indications, switches, and connectors on the front and rear panels of the instrument and describes the functions of the parts.

- 3.1 Front Panel of the Harmonics Analyzer
- 3.2 Rear Panel of the Harmonics Analyzer
- 3.3 Current Sensor

# 3.1 Front Panel of the Harmonics Analyzer

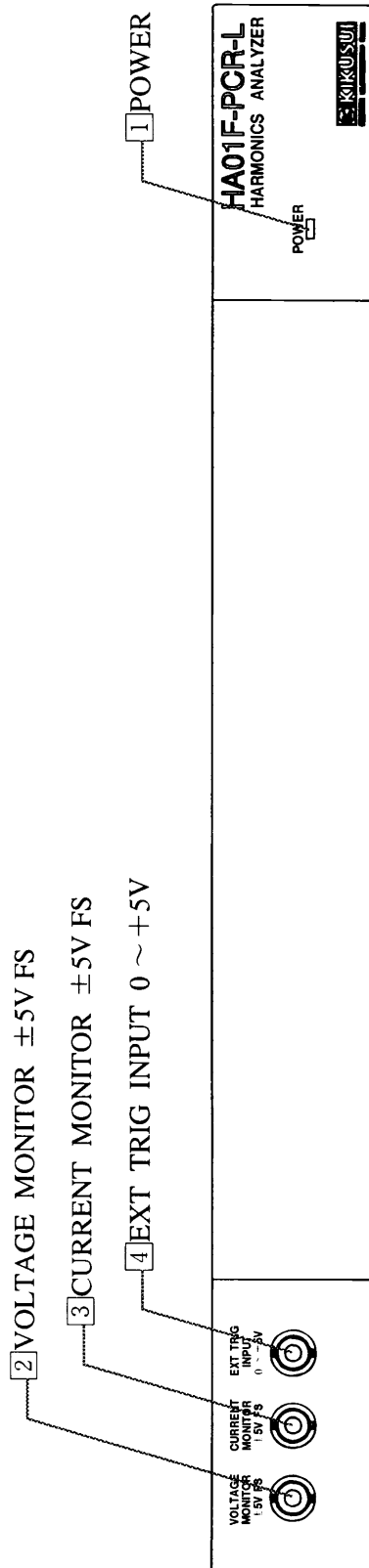

Fig. 3-1 Front Panel of the Harmonics Analyzer

### 1 POWER

Power indicator LED

### 2 VOLTAGE MONITOR $\pm 5VFS$

Enables the monitoring instrument to output the voltage signal under measurement. This output connector allows an oscilloscope to be connected for waveform observation.

Output voltage is  $\pm 5$  V full scale and is isolated from measured signals.

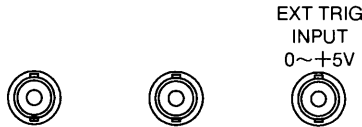

### 3 CURRENT MONITOR $\pm 5VFS$

Enables the monitoring instrument to output the current signal under measurement. This output connector allows an oscilloscope to be connected for waveform observation. Output voltage is  $\pm 5$  V full scale and is isolated from measured signals.

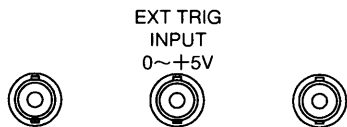

### 4 EXT TRIG INPUT 0 to +5V

Allows input of a trigger signal.

The terminal accepts a CMOS logic level signal of 0 to +5 V (negative logic), which should be given at level L (0.9 V or less) for  $1 \mu s$  or more. The validity of the input signal may depend on the software controlling the instrument.

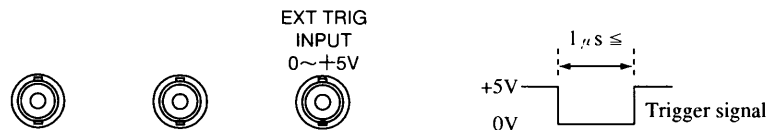

## Description

- The external metal parts of the VOLTAGE MONITOR, CURRENT MONITOR, EXT TRIG INPUT terminals have the same potential. These metal parts have a withstand voltage of 600 V<sub>peak</sub> with respect to the voltage or current-measurement terminal or measurement point.

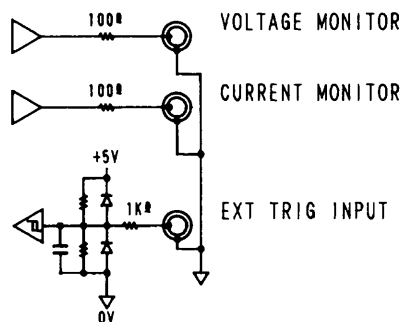

Fig. 3-2 BNC Connectors

## 3.2 Rear Panel of the Harmonics Analyzer

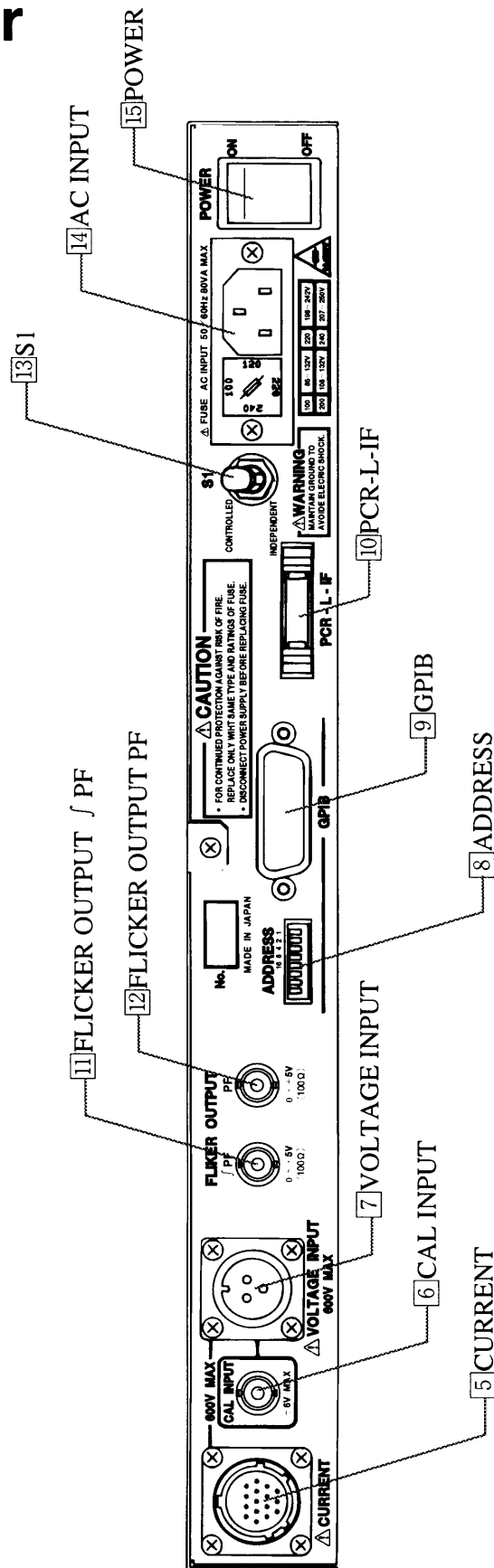

Fig. 3-3 Rear Panel of the Harmonics Analyzer

## 5 CURRENT

Connects the current-sensor cable (with 16 pins for current use). This connector accepts the socket connector of the current-sensor cable.

## 6 CAL INPUT

Input terminal for calibration. Generally, this terminal is not internally connected.

## 7 VOLTAGE INPUT

Connects the current-sensor cable (with 3 pins for voltage use). This connector accepts the socket connector of the current-sensor cable.

## 8 ADDRESS

GPIB address setting switch. For instructions on use, refer to the Software Operation Manual.

## 9 GPIB

GPIB connector for connecting a GPIB cable.

## 10 PCR-L-IF

Connects the flat cable which is provided to connect the instrument to the PCR-L-IF interface card. The HA01F-PCR-L receives synchronous clock pulses and controlled power-ON control signals from the PCR-L AC power supply through this cable.

## 11 FLCKER OUTPUT $\int$ PF

Indicates the output of the instantaneous flicker level signal with 1-minute integration. The signal level and insulation are the same as those for 12

## 12 FLCKER OUTPUT PF

Indicates the signal output equivalent to the instantaneous flicker level. The waveform of this signal can be observed by connecting an oscilloscope. The output voltage range is 0 to +5V and the output resistance is approx. 100 ohms. The logarithm of the flicker level is approx. + 0.85V with PF =1. The signal is insulated from measurement signals 5 and 6. The metallic exterior of the BNC terminal is connected to the metallic exterior of the GPIB terminal.

## 13 S1

Selects power-ON operation. This switch is a lock-type switch and requires the knob to be pulled for switching. The instrument is controlled by the *POWER* switch of the PCR-L AC power supply when the switch is set to CONTROLLED, or operates independently when set to INDEPENDENT.

#### 14 AC INPUT

50/60 Hz 80 VA max

Input socket for power supply. The input power cable provided should be connected to this socket. The instrument requires selection of the voltage selector, which also acts as a fuse holder, in accordance with the supply voltage.

Fuse: 250 V, 1 A normal type (6.3 diameter × 32 mm)

100	85V - 110V	220	198V - 242V
120	108V - 132V	240	207V - 250V

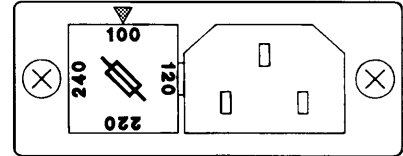

#### 15 POWER

Power switch. When the S1 switch is set to CONTROLLED, use the instrument with the POWER switch set to ON.

### 3.3 Current Sensor

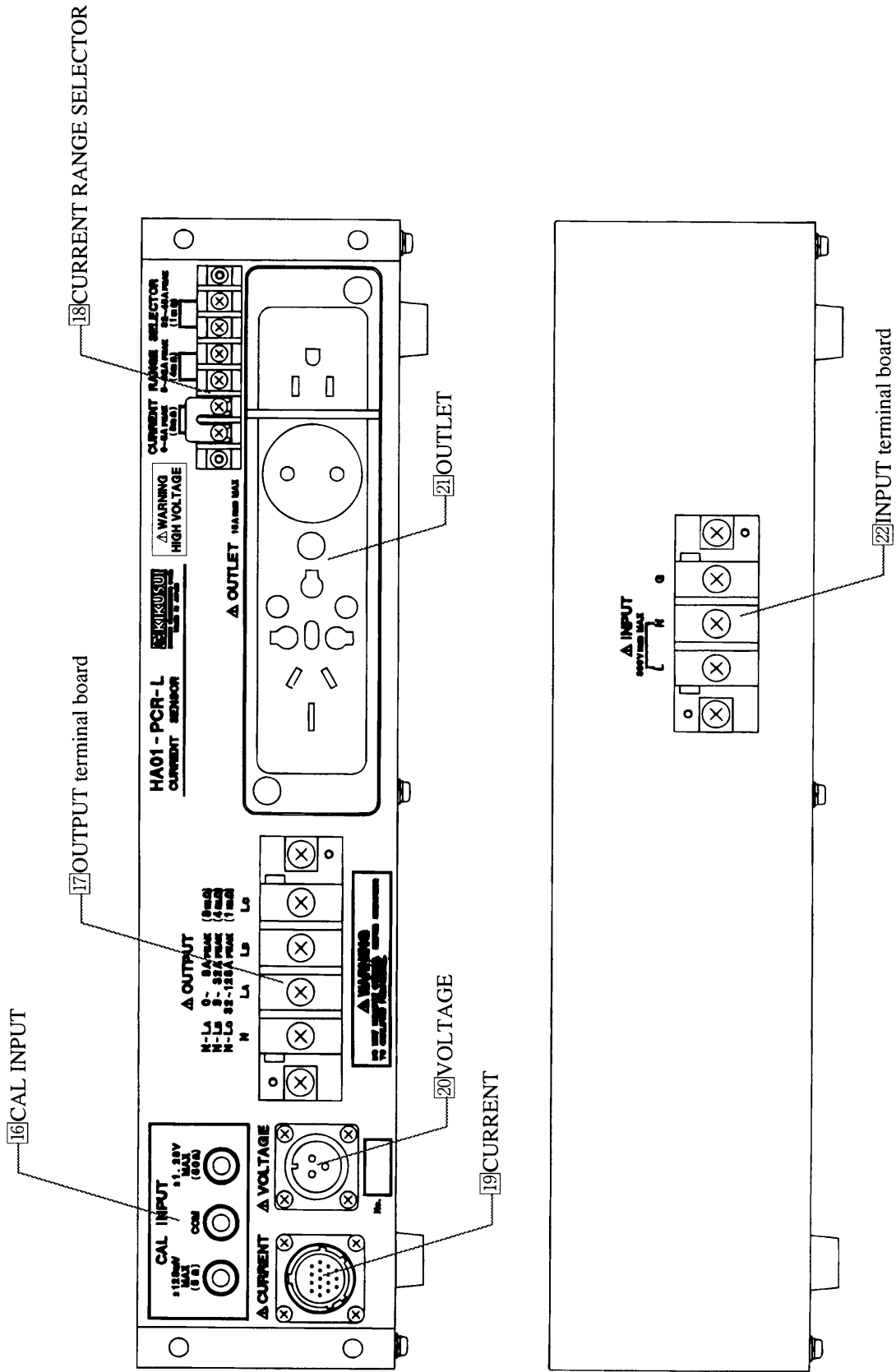

Fig. 3-4 Current Sensor

#### 16 CAL INPUT

Input terminal for calibration. This terminal is not generally used for measurements.

#### 17 OUTPUT terminal board

Output terminal board of the instrument. Connects the equipment under test (load). This terminal board can be regarded as an output terminal when the instrument is used in conjunction with the PCR-L AC power supply. The corresponding terminals must be used to meet the current-detecting resistance selected according to the load current.

#### 18 CURRENT RANGE SELECTOR

Since current-detecting resistance is selected in accordance with the load current from OUTLET, the corresponding range must be set using the short bar. This selector also switches the terminal voltage measurement of the equipment under test.

#### 19 CURRENT

Connects the current-sensor cable (with 16 pins for current use). This connector accepts the pin connector of the current-sensor cable.

#### 20 VOLTAGE

Connects the current-sensor cable (with 3 pins for voltage use). This connector accepts the pin connector of the current-sensor cable.

#### 21 OUTLET

Multi-outlets. If the input power cable of the equipment under test has a plug configuration, the input power cable is connected here. The OUTLET is compatible with most of the power plug configurations used worldwide.

#### 22 INPUT terminal board

Connect this terminal board to the OUTPUT terminal board of the PCR-L AC power supply or that of the LIN40MA-PCR-L.

The current sensor has current-detecting resistors between its INPUT and OUTPUT terminal boards.



# 4

## Chapter 4

### MAINTENANCE AND CALIBRATION

This chapter describes how to maintain, inspect, and calibrate the HA01F-PCR-L harmonics analyzer.

- 4.1 Cleaning
- 4.2 Inspection
- 4.3 Calibration

---

## 4.1 Cleaning

If the panel surface becomes dirty, gently wipe the surface using a soft cloth dampened with a diluted, neutral detergent.

### Caution

- Always turn the POWER switch OFF before cleaning.
- Do not use volatile substances such as thinner or benzene. Otherwise, the panel surface may become discolored, printed letters erased.

## 4.2 Inspection

### ■ Input power cable and cables provided

Check the input power cable and cables for torn coverings, loose plugs or connectors, or cracks.

### WARNING

- The presence of a torn covering may result in electrical shock. Immediately stop using the instrument and replace the torn cord or cable with a new one.
- For purchasing of accessories, contact your Kikusui agent.

## 4.3 Calibration

The HA01F-PCR-L harmonics analyzer has been properly calibrated upon shipment from the factory. However, recalibration may be necessary after long-term use.

### WARNING

- Since the product handles high voltage, calibration can be a dangerous operations. Accordingly, recalibration should only be performed by a Kikusui service engineer.

# 5

---

## Chapter 5

# SPECIFICATIONS

This chapter shows the electrical and mechanical specifications.

- 5.1 Current Measurement
- 5.2 Voltage Measurement
- 5.3 Harmonic Current Analysis
- 5.4 Voltage Variation Analysis
- 5.5 Flicker Measurement
- 5.6 Power Measurement
- 5.7 Current-Distortion-Factor Measurement
- 5.8 Monitoring Output
- 5.9 External Trigger Input
- 5.10 General Specifications
- 5.11 Dimensional Diagram

## 5.1 Current Measurement

Conditions where no specification is requested ( Temperature:  $23 \pm 5^{\circ}\text{C}$ , Fundamental wave: 50/60 Hz)

	Item	Conditions	Description
AC peak value measurement	Measurement range		1, 2, 4, 8, 16, 32, 64, 128A peak
	Maximum current RMS to be measured	<ul style="list-style-type: none"> <li>A value in parentheses indicates the current-detecting resistance.</li> <li>For a crest factor of 1.41</li> </ul>	5.65A RMS/8A peak (8m $\Omega$ ) 22.6A RMS/32A peak (4m $\Omega$ ) 40.0A RMS/128A peak (1m $\Omega$ )
	Accuracy	<ul style="list-style-type: none"> <li>At 50/60 Hz with filter set to OFF</li> <li>Positive or negative peak value, whichever is greater.</li> </ul>	1, 2, 4, 8, 16, 32A peak ranges: $\pm(0.75\%$ of rdg + $0.2\%$ of range) 64, 128A peak ranges: $\pm(2\%$ of rdg + $0.5\%$ of range)
	Frequency characteristics	<ul style="list-style-type: none"> <li>50 Hz to 2.4 kHz, 50 Hz standard</li> <li>With filter set to OFF</li> </ul>	$\pm 0.75\text{dB}$
AC RMS measurement	Measuring range		AC-peak value measurement range is used.
	Maximum RMS to be measured/ peak current	<ul style="list-style-type: none"> <li>A value in parentheses indicates the current-detecting resistance.</li> <li>For a crest factor of 1.41</li> </ul>	5.65A RMS/8A peak (8m $\Omega$ ) 22.6A RMS/32A peak (4m $\Omega$ ) 40.0A RMS/128A peak (1m $\Omega$ )
	Accuracy	<ul style="list-style-type: none"> <li>Range refers to the range of peak-value measurement.</li> <li>Input coupling is AC.</li> <li>At 50/60 Hz with filter set to OFF</li> </ul>	20 A RMS or less: $\pm(0.3\%$ of rdg + $0.075\%$ of range) More than 20A RMS to 40A RMS: $\pm(0.6\%$ of rdg + $0.15\%$ of range)
	Frequency characteristics	<ul style="list-style-type: none"> <li>50 Hz to 2.4 kHz, 50 Hz standard</li> </ul>	With filter set to ON: $\pm 2\text{dB}$ With filter set to OFF: $\pm 0.5\text{dB}$
	Current-detecting resistance (nominal value)		1 to 8A peak range: 8m $\Omega$ 8 to 32A peak range: 4m $\Omega$ 32 to 128A peak range: 1m $\Omega$

## 5.2 Voltage Measurement

Conditions where no specification is requested ( Temperature:  $23 \pm 5^{\circ}\text{C}$ , Fundamental wave: 50/60 Hz)

	Item	Conditions	Description
AC RMS measurement	Measurement range	For a crest factor of 1.41	20, 40, 80, 160, 320, 600V RMS
	Maximum voltage to be measured		600V RMS
	Accuracy	<ul style="list-style-type: none"> <li>At 50/60 Hz with filter set to OFF</li> </ul>	$\pm (0.3\%$ of rdg + $0.075\%$ of range)
	Frequency characteristics	<ul style="list-style-type: none"> <li>50 Hz to 2.4 kHz, 50 Hz standard</li> <li>With filter set to OFF</li> </ul>	$\pm 0.5\text{dB}$
	Input resistance		Approx. 4M $\Omega$

## 5.3 Harmonic Current Analysis

Conditions where no specification is requested ( Temperature:  $23 \pm 5^\circ\text{C}$ , Fundamental wave: 50/60 Hz)

Item		Conditions	Description	
Method			Time-domain-type measurement using discrete Fourier transform (DFT)	
Number of operation data points			256 to 16384	
Processing word length			32 bits	
Window (Fundamental cycle count)			1, 2, 4, 8, 16, 32, 64	
Window function			Rectangular window	
Continuous analysis time			2.5 minutes maximum No gaps or overlap between windows	
Harmonics analysis accuracy	20A RMS or less	Fundamental wave	<ul style="list-style-type: none"> <li><math>n = 2, 3, 4, \dots, 40</math> (2nd to 40th order)</li> </ul>	$\pm (0.3 \% \text{ of rdg} + 0.075\% \text{ of range})$
		Harmonics	<ul style="list-style-type: none"> <li>"Range" refers to the range of peak value measurement.</li> </ul>	$\pm \{0.3 (1 + \sqrt{n}) \% \text{ of rdg} + 0.04 \% \text{ of range}\}$
	More than 20A RMS to 40A RMS	Fundamental wave	<ul style="list-style-type: none"> <li>With filter set to ON</li> <li>For input of triangular wave</li> </ul>	$\pm (0.6 \% \text{ of rdg} + 0.15 \% \text{ of range})$
		Harmonics		$\pm \{0.6 (1 + \sqrt{n}) \% \text{ of rdg} + 0.15 \% \text{ of range}\}$
Anti-aliasing filter's aliasing attenuation			70 dB or more	
Averaging			Exponential averaging by a first-order low-pass filter with 1.5 seconds $\pm 10\%$ time constant	
Synchronization			Synchronization based on PCR-L series AC power supply clock (PCR-L series frequency clock accuracy $\pm 1 \times 10^{-4}$ )	

## 5.4 Voltage Fluctuation Analysis

Conditions where no specification is requested ( Temperature:  $23 \pm 5^{\circ}\text{C}$ , Fundamental wave: 50/60 Hz)

Item	Conditions	Description
Fluctuation analysis		1 ) Voltage change measurement $\Delta U(t)$ 2 ) Maximum voltage change measurement $\Delta U \text{ max}$ 3 ) Steady state voltage change measurement $\Delta U_c$ 4 ) Relative voltage change characteristic measurement $d(t)$ 5 ) Maximum relative voltage change measurement $d \text{ max}$ 6 ) Relative steady state voltage change measurement $dc$
RMS definition time		50/60 Hz half cycle
Accuracy	<ul style="list-style-type: none"> <li>• Voltage range (V range) is either 160 V RMS or 320 V RMS</li> <li>• To 2% or more voltage change of the V range</li> <li>• Nominal input voltage: 100 V RMS, 230 V RMS</li> <li>• With filter set to OFF</li> </ul>	$\Delta U(t)$ , $\Delta U \text{ max}$ , $\Delta U_c$ : $\pm(0.3\% \text{ of rdg} + 0.075\% \text{ of V range})$ $d(t)$ , $d \text{ max}$ , $dc$ : $\pm(0.6\% \text{ of rdg} + 0.15\% \text{ of V range})$

## 5.5 Flicker Measurement

Conditions where no specification is requested ( Temperature:  $23 \pm 5^{\circ}\text{C}$ , Fundamental wave: 50Hz)

Item	Condition	Description
Flicker evaluation (signal phase)		
Evaluation method	Necessary reference impedance · Voltage line : $0.24 + j0.15 (\Omega)$ · Neutral line : $0.16 + j0.10 (\Omega)$ 230V,50Hz * LIN40MA-PCR-L line impedance network	Evaluation and standard determination based on IEC1000-3-3; short-time flicker value (Pst) or long-time flicker value (Plt). Pst or Plt is measured with the flicker meter based on IEC868 and IEC868-0.
Measurement time		Pst measurement : 1min, 5min, 10min Plt measurement : 2h to 24h
Flicker meter (signal phase)		
Measurement rating voltage (nominal)		100V, 200V, 230V (50Hz)
Measurement items		· Short-time flicker value (Pst) · Long-time flicker value (Plt) Accumulated probability density distribution of the flicker level
Accuracy	Under the Table A1 condition prescribed by IEC868 Amendl. A4 (Performance testing)	Pst = $1 \pm 5\%$
Output		· Direct output : approx. 0.85V (at PF=1) · Output with 1-min integration : approx 0.85V (at PF=1)

## 5.6 Power Measurement

Conditions where no specification is requested ( Temperature:  $23 \pm 5^{\circ}\text{C}$ , Fundamental wave: 50/60 Hz)

Item	Conditions	Description
Maximum power to be measured		6.4kW
Accuracy	20A RMS or less · 50/60 Hz · Both voltage and current are obtained when an input of 25% or more of the voltage or current range is made. · Range: A combination of voltage range (AC RMS measurement range) and current range (AC peak-measurement range)	$\pm(0.6\% \text{ of rdg} + 0.15\% \text{ of range})$
	More than 20A RMS to 40A RMS · Voltage range is selected regarding the crest factor as 1.41. · At a power factor of 1.0	$\pm(0.9\% \text{ of rdg} + 0.2\% \text{ of range})$
Power-factor measurement	· 50/60 Hz · Both voltage and current are obtained when an input of 25% or more of the voltage or current range is made.	0.000 to $\pm 1.000$

## 5.7 Current-Distortion-Factor Measurement

Conditions where no specification is requested (fundamental wave: 50/60 Hz, temperature:  $23 \pm 5^\circ\text{C}$ )

Item	Conditions	Description
Definition of distortion factor		U1: Fundamental wave level Un: Harmonics level n: 2, 3, .....40 $\frac{1}{U_1} \sqrt{\sum_{n=2}^{40} U_n^2} \times 100(\%)$
Measuring range		0.2% - 255%
Accuracy	20A RMS or less	· The current obtained when an input of 25% or more of the current range is made.
	More than 20A RMS to 40A RMS	
		$\pm(6\% \text{ of rdg} + 0.4\% \times 100/\text{rdg})$
		$\pm(7.5\% \text{ of rdg} + 0.8\% \times 100/\text{rdg})$

## 5.8 Monitoring Output

Conditions where no specification is requested (monitoring voltage/current, temperature:  $23 \pm 5^\circ\text{C}$ )

Item	Conditions	Description
Output voltage		$\pm(5V \pm 10\%)$ full scale
Output DC offset voltage		$\pm 0.1V$ or less
Output resistance		Approx. $100\Omega$

## 5.9 External Trigger Input

Conditions where no specification is requested (temperature:  $23 \pm 5^\circ\text{C}$ )

Item	Conditions	Description
Signal level		0 to +5V(CMOSlevel) A trigger signal is accepted at level L.



## 5.10 General Specifications

Item		Condition	Description
Operating environment	Temperature range		23°C ±5°C
	Humidity range		20% to 80% R.H. (no condensation)
Warm-up period			Approx. 30 minutes
Insulation resistance	Voltage input to case		500 V DC, 50MΩ or more
	Current input to case		
	Voltage input to current input		
	Voltage input to voltage monitoring output		
	Current input to current monitoring output		
	Power plug to case		
Withstand voltage	Voltage input to case		600 V <sub>peak</sub> continuous, 1.5 kV AC for 1 minute
	Current input to case		600 V <sub>peak</sub> continuous, 1.5 kV AC for 1 minute
	Voltage input to current input		600 V <sub>peak</sub> continuous
	Voltage input to voltage monitoring output		600 V <sub>peak</sub> continuous
	Current input to current monitoring output		600 V <sub>peak</sub> continuous
	Power plug to case		1.5 kV AC for 1 minute
Power supply	Frequency		50/60Hz
	Setting range		100: Voltage range 85 V to 110 V 120: Voltage range 108 V to 132 V 220: Voltage range 198 V to 242 V 240: Voltage range 207 V to 250 V
	Power consumption	100VAC, 50Hz	80 VA maximum
Terminal screw	Input terminal		M6
	Output terminal		M6
Dimensions and weight	Harmonics analyzer	Dimensions	430W×44H×550D mm (Maximum part: 430 W×44 H×590 D mm)
		Weight	9kg
	Current sensor	Dimensions	416W×93H×170D mm (Maximum part: 416 W×103 H×260 D mm)
		Weight	4kg

## Accessories list

Accessories		Q'ty
1	Current sensor cable (with 16 pins 3m for current)	1
2	Current sensor cable (with 3 pins 3m for voltage)	1
3	Current sensor cable (For terminal board, 60cm, with M6 crimped terminal)	3
4	PCR-L interface card	1
5	PCR-L interface card flat cable	1
6	PCR-L interface card mounting screws (M3)	2
7	Input power cable	1
8	3-pin to 2-pin conversion adapter for the input power cable	1
9	Magnet sheets	4
10	Operation Manual	1

# 5.11 Dimensional Diagrams

## 5.11.1 Harmonics Analyzer

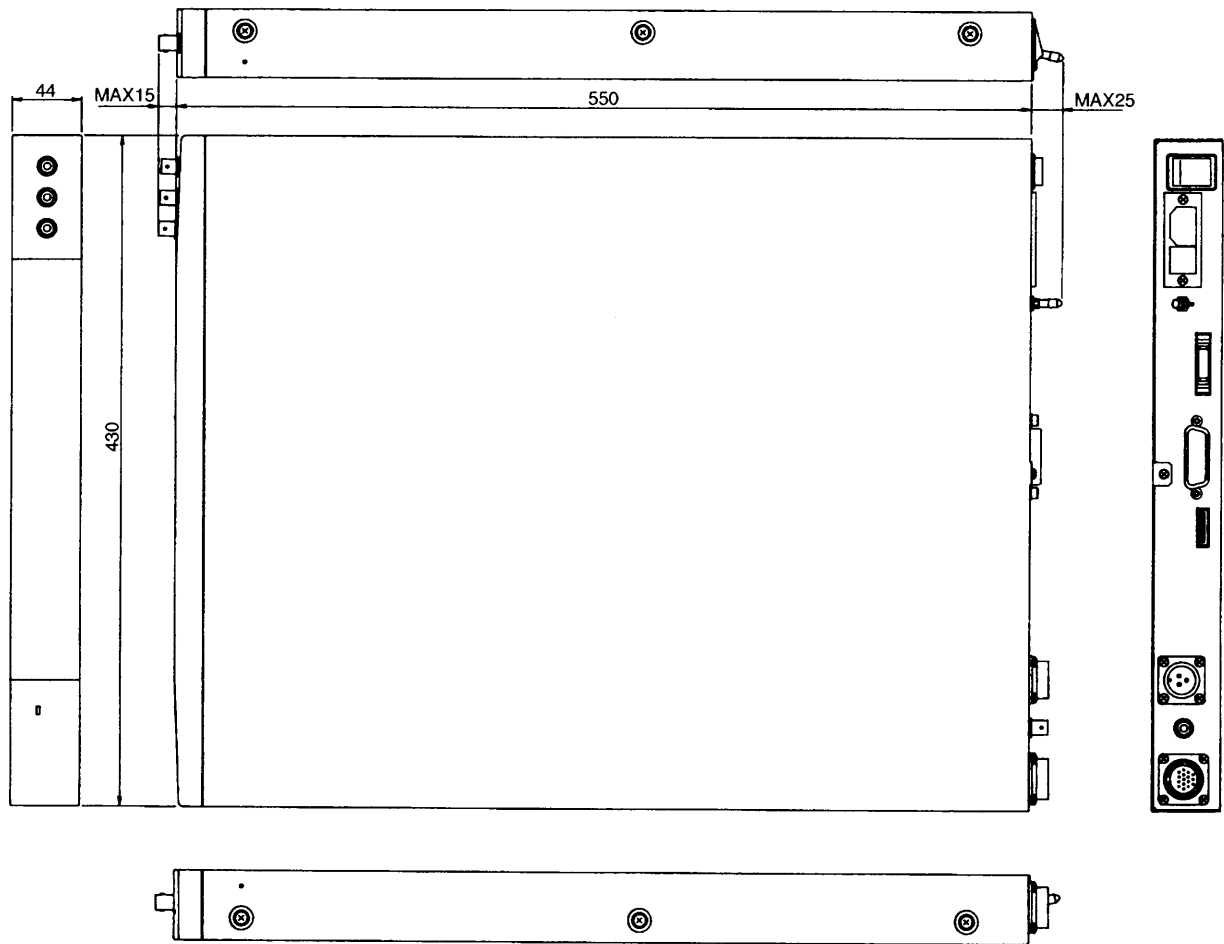

Fig. 5-1 Dimensions of Harmonics Analyzer

## 5.11.2 Current Sensor

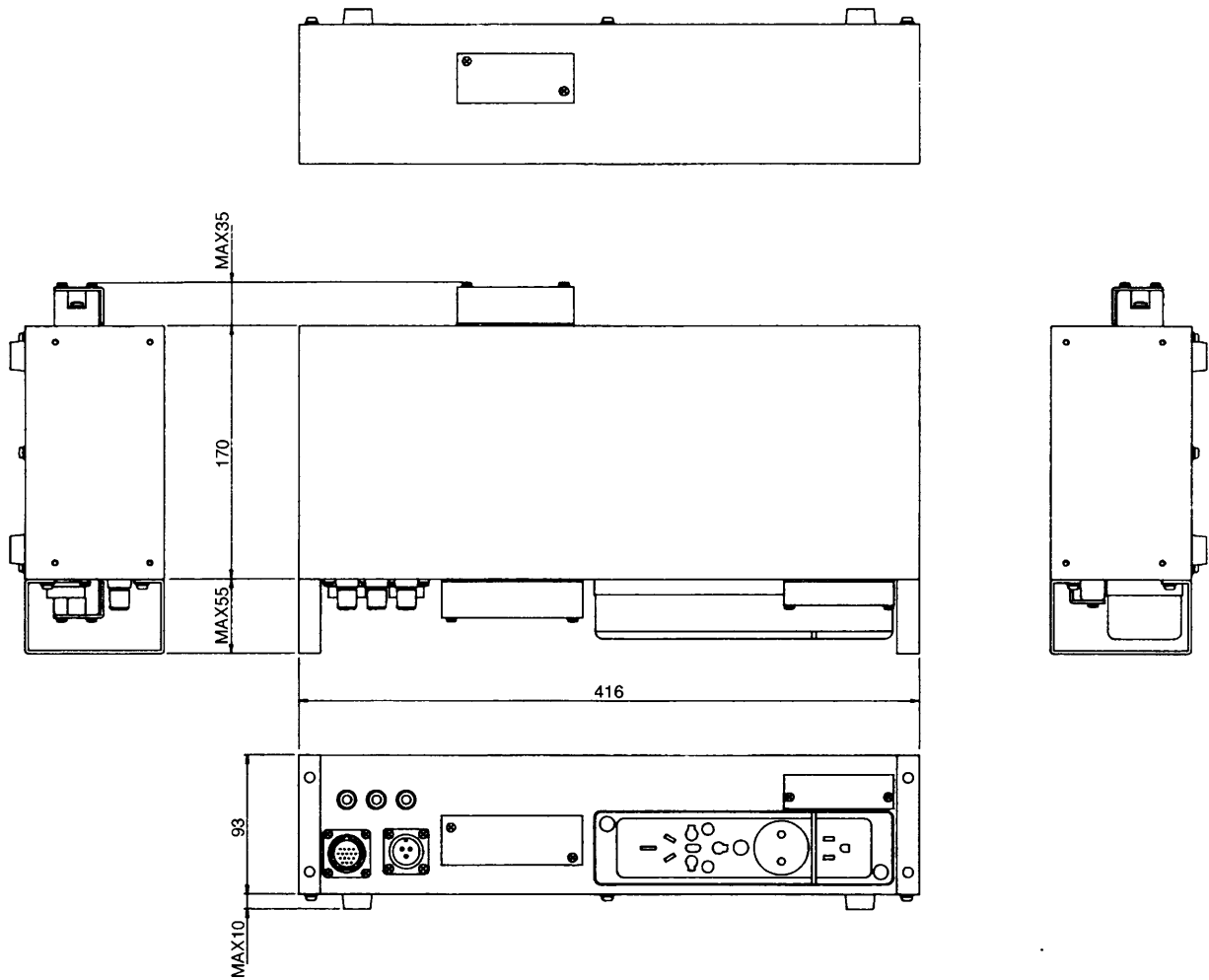

Fig. 5-2 Dimensions of Current Sensor

# APPENDIX

Appendix 1 Loss in Power Measurement

Appendix 2 Relationship Between Peak Value and RMS Value for Voltage-  
and Current-Measurement Ranges

## Appendix 1 Loss in Power Measurement

The power-measurement circuit of the HA01F-PCR-L harmonics analyzer is as shown in Fig. A-1.

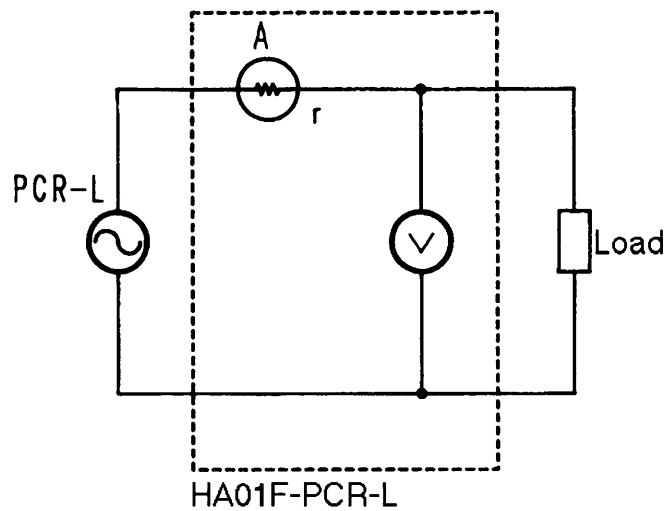

Fig. A-1 Power Measurement Circuit

Power loss is caused as described below due to internal resistance  $r$  (current detecting resistance) of the ammeter.

### (1) Example of calculating power loss

Where internal resistance is in the  $8\text{ m}\Omega$  range:

- 1) For measurement of  $5.65\text{ A}$  ( $5.65 = 8/\sqrt{2}$ )

$$(5.65)^2 \times 8\text{m}\Omega = 0.26\text{W}$$

- 2) For measurement of  $\frac{8}{3}\text{ A}$  ( $= 2.67\text{ A}$ ) ( $22.6 = 32/\sqrt{2}$ )

$$\left(\frac{8}{3}\right)^2 \times 8\text{m}\Omega = 0.057\text{W}$$

Where internal resistance is in the  $4\text{ m}\Omega$  range:

- 1) For measurement of  $22.6\text{ A}$

$$(22.6)^2 \times 4\text{m}\Omega = 2.04\text{W}$$

- 2) For measurement of  $\frac{32}{3}\text{ A}$  ( $= 10.67\text{ A}$ )

$$\left(\frac{32}{3}\right)^2 \times 4\text{m}\Omega = 0.46\text{W}$$

---

Where internal resistance is in the 1 mΩ range:

1) For measurement of 40 A

$$40^2 \times 1\text{m}\Omega = 1.6\text{W}$$

Example of calculating power loss caused by the voltmeter input resistance

When input resistance is 4 MΩ, power loss becomes as follows with respect to 600 V input.

$$\frac{600 \times 600}{4 \times 10^6} = 0.09\text{W}$$

## Appendix 2 Relationship Between Peak Value and RMS Value for Voltage-and Current-Measurement Ranges

### (1) Relationship between voltage-measurement ranges and peak values

The relationship between the voltage-measurement ranges (specified by peak value. The peak value is determined by a positive or negative peak, whichever is greater) and measurable peak values is shown in Table A-1.

When the voltage waveform crest factor is 3, the RMS that can be measured at each range is as shown in Table A-1.

Voltage range	Allowable peak values	Maximum measurable RMS
		For a crest factor of 3
V RMS	V PEAK	V RMS
20	28.28	9.43
40	56.56	18.8
80	113.1	37.7
160	226.2	75.4
320	452.5	150
600	848.5	282

Table A-1 Relationship between Voltage-Measurement Ranges and Peak Values



## (2) Relationship between current-measurement ranges and peak values

The relationship between the current-measurement ranges (specified by peak value. The peak value is determined by a positive or negative peak, whichever is greater) and measurable RMS values is shown in Table A-2.

When the current waveform crest factor is 3, the RMS that can be measured at each range is as shown in Table A-2.

Current waveform with a crest factor of 3 is generally equivalent to input current waveform in a capacitor-input-type rectifying circuit.

Current-detecting resistance	Current range	Maximum measurable RMS	
		For a crest factor of 1.41	For a crest factor of 3
mΩ	A PEAK	A RMS	A RMS
8	1	0.707	0.333
	2	1.41	0.666
	4	2.82	1.33
	8	5.65	2.66
4	2	1.41	0.666
	4	2.82	1.33
	8	5.65	2.66
	16	11.3	5.33
	32	22.6	10.66
1	8	5.65	2.66
	16	11.3	5.33
	32	22.6	10.66
	64	40.0	21.3
	128	40.0	40.0

Table A-2 Relationship between Current Measurement Range and Peak Values

# INDEX

## A

AC INPUT .....	3-6
Accessories .....	1-3
ADDRESS .....	3-5

## C

CAL INPUT .....	3-5, 3-8
Calibration .....	4-2
Checking Operations .....	2-2
Cleaning .....	4-2
Connecting the GPIB Cable .....	1-12
Connecting the Power Supply .....	1-13
Connection to the PCR-L AC Power Supply ....	1-7
Controlled Operation .....	2-3
CURRENT .....	3-5, 3-8
Current Measurement .....	5-2
CURRENT MONITOR $\pm$ 5VFS .....	3-3
CURRENT RANGE SELECTOR .....	3-8
Current-Distortion-Factor Measurement .....	5-6
current-measurement ranges and peak values .	A-5
Current-Sensor Cables .....	1-9

## D

Dimensional Diagrams .....	5-9
Dimensions .....	5-7

## E

Example of calculating power loss .....	A-2
EXT TRIG INPUT 0 to +5V .....	3-3
External Trigger Input .....	5-6

## F

FLCKER OUTPUT .....	3-5
Flicker Measurement .....	5-5
Fuse Holder .....	1-13
Fuses .....	1-13

## G

GPIB .....	3-5
Grounding .....	1-6

## H

Harmonic Current Analysis .....	5-3
---------------------------------	-----

## I

Independent Operation .....	2-2
Indications and Input Voltage Range .....	1-13
INPUT terminal board .....	3-8
Inspection .....	4-2
Installation Location .....	1-4
Insulation resistance .....	5-7
Interface Card .....	1-10

## M

Magnetic Sheets .....	1-5
Maximum Current .....	2-7
Monitoring Output .....	5-6

## O

Operating environment .....	5-7
Optional Bracket .....	1-14
OUTLET .....	3-8
OUTLET (Multi-outlet) .....	2-4
OUTPUT Terminal Board .....	2-6, 3-8

## P

packing .....	1-2
Packing/Unpacking .....	1-2
PCR-L-IF .....	3-5
POWER .....	3-3, 3-6
Power Measurement .....	5-5
Power supply .....	5-7

## S

S1 .....	3-5
Setting the CURRENT-RANGE SELECTOR .	2-5

## T

terminal G .....	1-6
Terminal screw .....	5-7

## V

VOLTAGE .....	3-8
Voltage Fluctuation Analysis.....	5-4
VOLTAGE INPUT .....	3-5
Voltage Measurement .....	5-2
VOLTAGE MONITOR $\pm$ 5VFS .....	3-3
voltage-measurement ranges and peak values .	A-4

## W

Warm-up .....	2-3
Warm-up period .....	5-7
Weight .....	5-7
When Using the LIN40MA-PCR-L.....	1-11
Withstand Voltage .....	5-7